

**HALIFAX**

*Since 1991*

---

Halifax è un marchio storico, nato negli anni '90 nel cuore della Brianza, culla di sapienti artigiani e del manufatto artigianale, grazie alla straordinaria sapienza nell'arte della lavorazione del legno, alla selezione dei materiali migliori, ha realizzato e realizza ancora oggi un prodotto curato nel dettaglio e dalle pregiate finiture.

La nostra attenzione è sempre stata quella di trasformare la materia in un oggetto funzionale ma al contempo di design. Halifax nasce con prodotti realizzati in massello di legno dal sapore della memoria, ne sono l'esempio il tavolo Winston, la vetrina Vetriera, l'espositore Bacheca, che oggi, dopo 25 anni, riproponiamo con legni alternativi come "cultura del bello" e salvaguardia di soluzioni uniche e di grande personalità.

L'identificazione del made in Italy viene altresì distinta nello stile del contemporaneo, nella stravagante ricercatezza del prodotto d'autore, regalando ad ogni ambiente carattere e autenticità.

---

*Halifax is a historic brand, born in the 90's at the heart of Brianza, cradle of master craftsmen, manufacturers of amazing hand-crafted works thanks to their skill in selecting the best materials and their advanced know-how in woodwork. Halifax always manufactured, during the years till nowadays, a highly refined product, extremely accurate in details and in the choice of the most precious finishes.*

*Our attention always focused on transforming the material into a functional object and a design object at the same time. Halifax initial collection offers a range of products manufactured in solid wood, with hints of memory, like the table Winston, the vitrine Vetriera and the showcase Bacheca. After 25 years we are re-proposing these items with alternative woods. Our heritage of beauty and unique solutions characterized by a strong personality.*

*The Made in Italy identifies with the style of Contemporaneo and with the inspired elegance of Collezione d'Autore, giving to each room character and authenticity.*

## LE MEMORIE

Ginevra	8
Isotta	10
Winston	12
Vassoia	14
Espositore console	16
Cassettaio	18
Bacheca	20
Vetriera	22



## CONTEMPORANEO

### Poltrone e Divani *Armchairs and sofas*

Bubble e pouff	28
Double	30
Kompasso	32
Point	34
Ambrogio	36
Blade	40
Cover	44
Lama	46

### Sedie *Chairs*

Minni sedia	54
Minni sgabello	56
Teodolinda	58
Hosteria	62

### Tavoli e Tavolini *Tables and Coffee Tables*

Ulisse	66
Vittorio fisso	68
Vittorio 300	70
Nodo	72
Hosteria	74
Carpenter	76
Mirto	78
Vittorio tavolino	80
Quadro	82
Naos	84
Art - Art Light	86
Swing	88



### Contenitori e Librerie *Storage Units and Bookcases*

Lisboa	92
Half Lisboa	96
Extra	98
Achille	100
Square	102

### Letti *Beds*

Ania	106
Karma	108
Thai	110
Taffy	114
Nikka	116
Japo	118
Quito	120

### Comodini e Cassettiere *Night Tables and Chests of Drawers*

Aero	124
Taffy	126
Pyllon	130
Traccia	132

### Specchi *Mirrors*

Imago	136
Tokyo	138
Venezia	140
Riflessi	142



## COLLEZIONI D'AUTORE

### Poltrone e Divani *Armchairs and sofas*

Serena	146
Feltrino	148
501	150
Intrecci poltrona	152
Intrecci divano	154
Intrecci collection 2-3-4 angolo	156
Luna di miele	158
Marilyn	160
Stealth	162
Boccaccio	164
Sartoriale	168

### Sedie *Chairs*

Annette	176
---------	-----

### Tavoli e Tavolini *Tables and Coffee Tables*

Righetta	180
Ivory - Black Swan Fisso	182
Ivory - Black Swan 300	184
Ivory - Black Swan tavolino	186
Intrecci 9.9	190



### Contenitori e Librerie *Storage Units and Bookcases*

Taglia e cuci	194
Ivory	196
Network	198

### Letti *Beds*

Le pieghe	202
Atelier	206

### Comodini e Cassettiere *Night Tables and Chests of Drawers*

Le pieghe	210
-----------	-----

### Specchi e Appendiabiti *Mirrors and Cloth-Hangers*

Pittura fresca	214
Macchia	216
Righetta Specchio	218
Cessato Specchio	219

## OUTDOOR

Casper	222
Casper sofa	224
Casper chaise longue	226
Art Apple	227
Adamo&Eva	228
Nu•Ovo	230





**ELEMENTI D'ARREDO INTRAMONTABILI,  
MADIE E CONTENITORI, ASSOCIATI AD UN  
DESIGN SEMPLICE ED ELEGANTE . LIBRERIE  
COME SCULTURE CHE CON I MATERIALI  
E LE FORME DIVENTANO PEZZI UNICI.**

*TIMELESS FURNITURE PIECES, SIDEBOARDS AND STORAGE  
ELEMENTS SHOWING A PLAIN AND ELEGANT DESIGN.  
BOOKCASES LIKE SCULPTURES TRANSFORMING MATERIALS  
AND SHAPES INTO UNIQUE PIECES.*

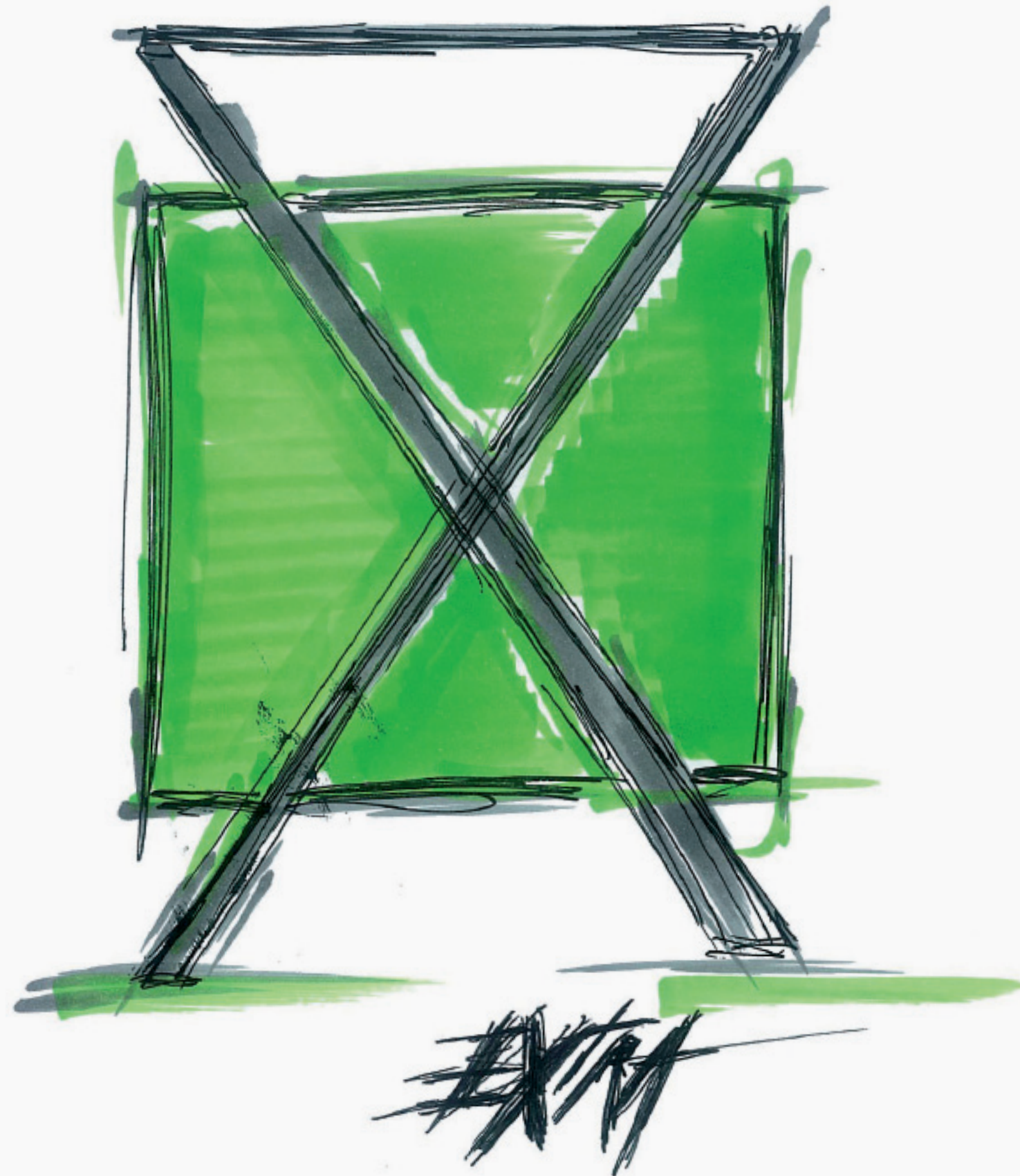

## CONTEMPORANEO

### **Contenitori e Librerie** *Storage Units and Bookcases*

Lisboa	92
Half Lisboa	96
Extra	98
Achille	100
Square	102



# Lisboa

DESIGN ENRICO FRANZOLINI

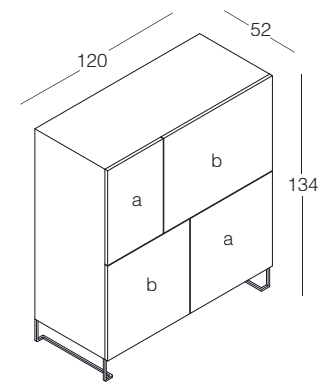

Contenitore in legno a quattro ante. Piedini in metallo finitura canna di fucile.

Wooden storage unit with four doors. Metal feet finish canna di fucile.







Galerie Sian

Keizersgracht 267  
Amsterdam





# Half Lisboa

DESIGN ENRICO FRANZOLINI

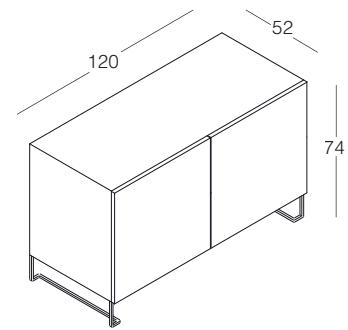

Contenitore in legno a due ante. Piedini in metallo finitura canna di fucile.

Wooden storage unit with two doors. Metal feet finish canna di fucile.





# Extra

DESIGN RICCARDO ARBIZZONI

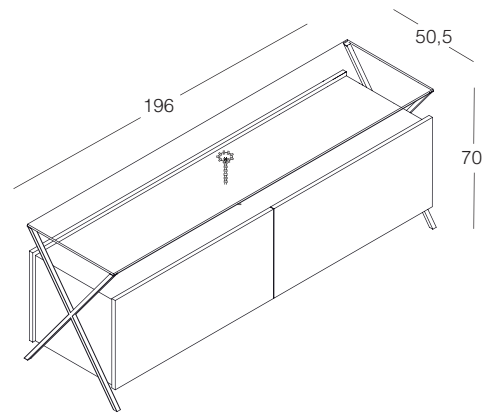

Contenitore in legno a due cassetti esterni e due vassoi interni, piano superiore in vetro trasparente temperato con struttura in acciaio e finitura canna di fucile.

Wooden storage unit with two drawers and two internal extractable trays. Top in transparent tempered glass. Structure in stainless steel finish canna di fucile.



# Achille

DESIGN VITTORIO PRATO

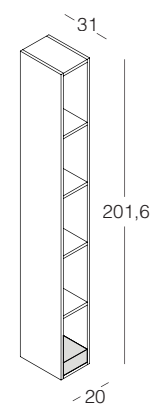

Contenitore libreria in legno e laccato, con pietra stabilizzante alla base in marmo Marquina. *Bookcase unit in wood or lacquer finish, with stabilizing stone at the base in marble Marquina.*





# Square

DESIGN GIUSEPPE VIGANÒ

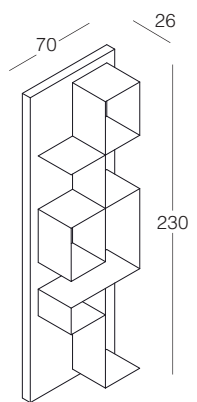

Libreria posizionabile in senso orizzontale o verticale.  
Ripiani in lamiera piegata e verniciata, pannello in  
essenza o laccato.

*Bookcase unit to be horizontally or vertically positioned.  
Shelves in folded and varnished metal sheet. Back panel  
in wood or lacquer finish.*





**MATERIALI RAFFINATI, VELLUTI E PELLI,  
ARMONICHE ALTERNANZE DI VOLUMI, DI VUOTI  
E PIENI VESTONO LA NOTTE DEI SOGNI.**

*REFINED MATERIALS, VELVET AND LEATHERS, A HARMONIOUS  
SEQUENCE OF VOLUMES, OF EMPTY AND FULL, DRESSING UP  
THE NIGHT OF DREAMS.*

## CONTEMPORANEO

---

### **Letti** *Beds*

Ania	106
Karma	108
Thai	110
Taffy	114
Nikka	116
Japo	118
Quito	120

# Ania

DESIGN CRS HALIFAX

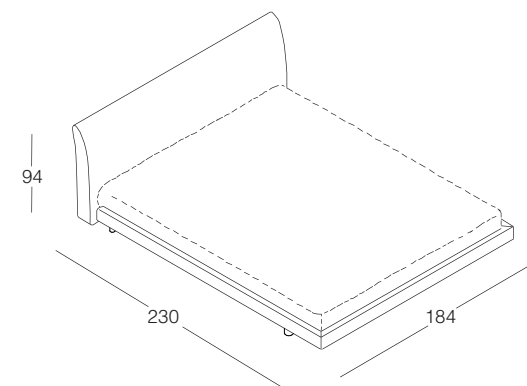
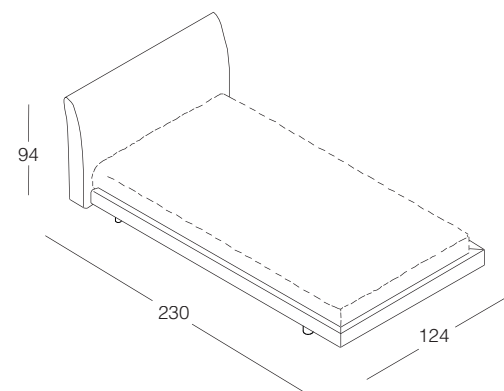

Letto con testata e base imbottite e rivestite con tessuto sfoderabile o in pelle fisso.

*Upholstered headboard and base padded and covered with removable fabric or non removable leather.*





# Karma

DESIGN CRS HALIFAX

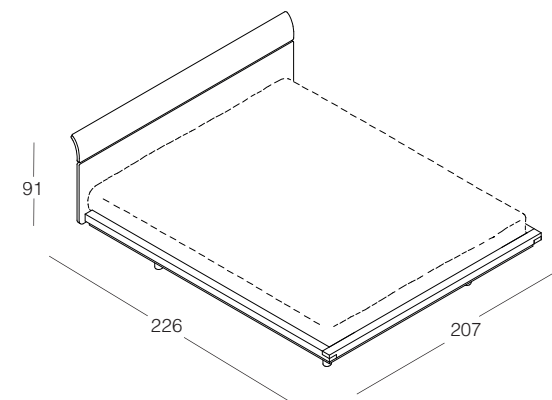
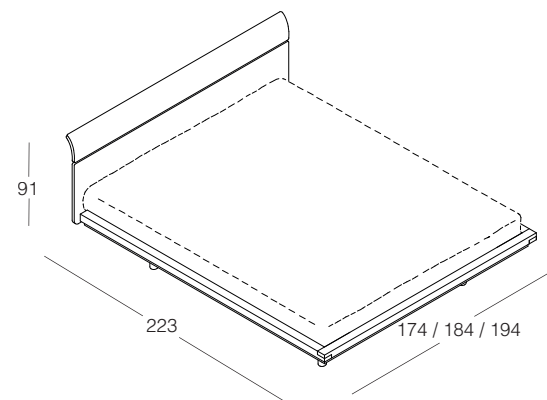

Letto con testata in multistrato curvato visibile ai bordi e base quadra in massello rivestito.

*Bed with headboard made of curved plywood, edges at sight, and square base in veneered solid wood.*





# Thai

DESIGN CRS HALIFAX

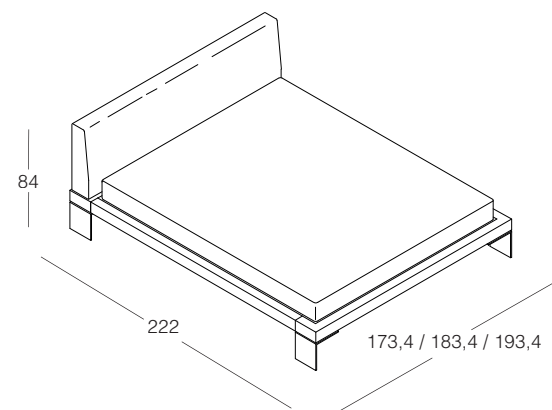

Letto con fascia in legno o rivestita in tessuto sfoderabile o in pelle fisso. Testata rivestita in tessuto sfoderabile o in pelle fisso. Piedi in metallo finitura canna di fucile.

*Bed with base frame in wood or covered with removable fabric or non removable leather. Headboard covered with removable fabric or non removable leather. Metal feet finish canna di fucile.*









# Taffy

DESIGN ENNIO AROSIO

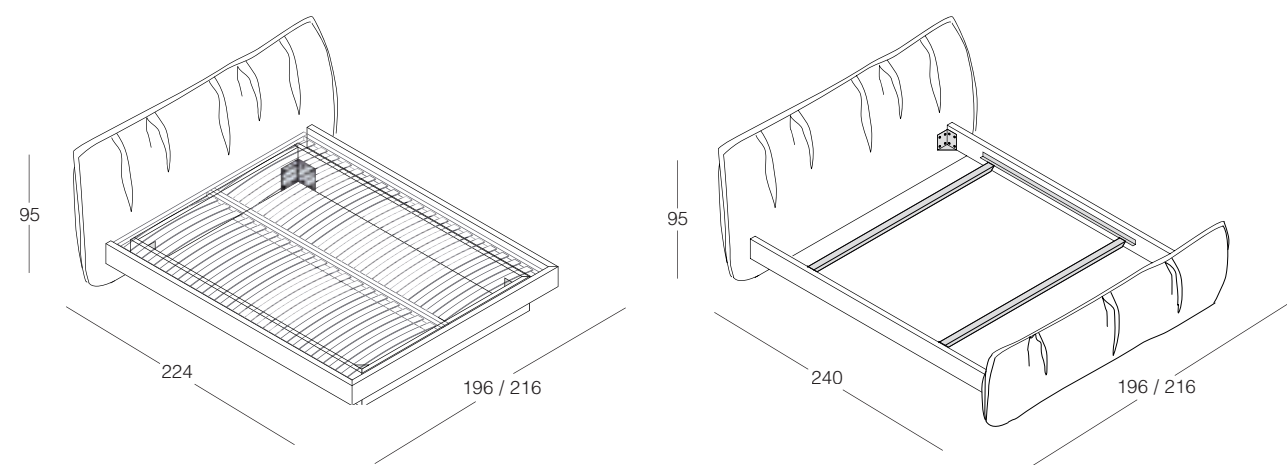

Letto con testata imbottita disponibile in due versioni: con pediera imbottita o con contenitore. Rivestimento in tessuto sfoderabile.

*Bed with upholstered headboard available in two versions: with upholstered footboard or with storage. Removable fabric cover.*





# Nikka

DESIGN MARCO BOGA

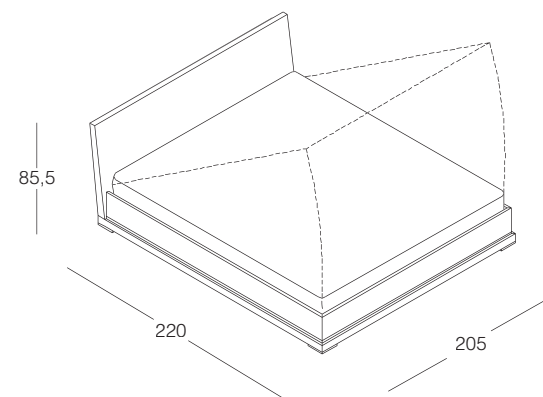
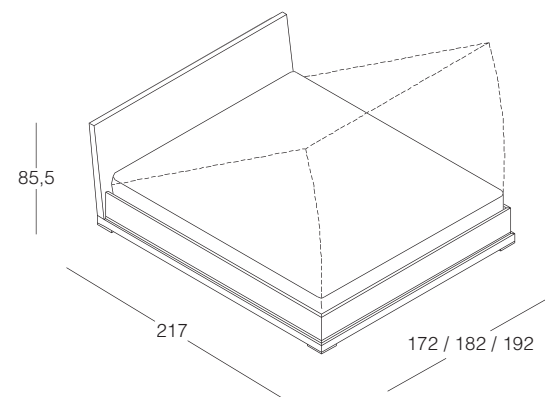

Letto con contenitore, testata legno e base imbottita rivestita con tessuto o pelle sfoderabili.

Storage bed with wooden headboard and upholstered base, covered with removable fabric or leather.





# Japo

DESIGN CRS HALIFAX

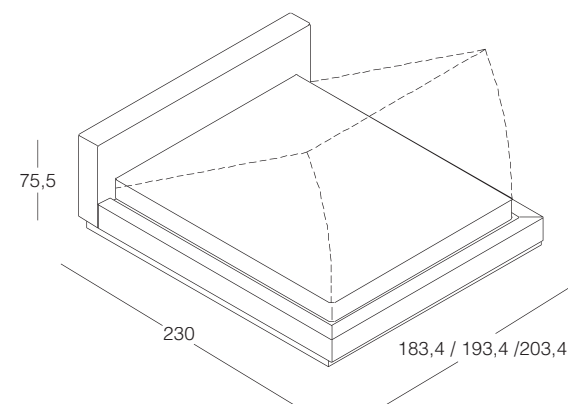

Letto con contenitore, con testata e base imbottite.  
Rivestimento in tessuto sfoderabile o in pelle fisso.

*Storage bed with upholstered headboard and base.  
Removable fabric cover or non removable leather cover.*





# Quito

DESIGN CRS HALIFAX

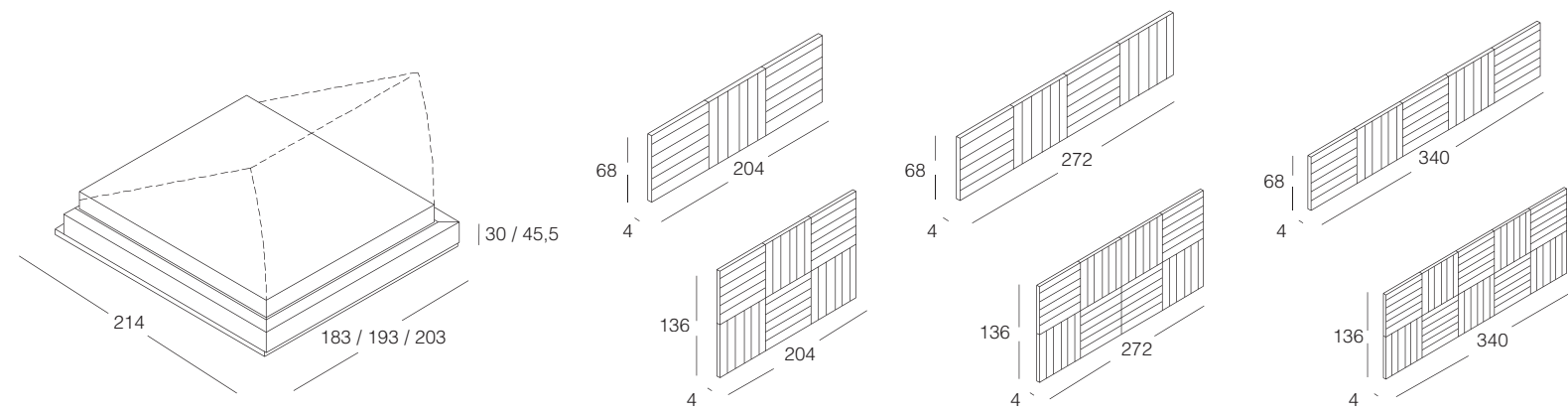

Letto con contenitore, con testata a pannelli in legno e base imbottita. Rivestimento in tessuto sfoderabile o in pelle fisso.

*Storage bed with wooden panels headboard and upholstered base. Removable fabric cover or non removable leather cover.*





**CASSETTIERA DI ALTEZZA CONTENUTA,  
DAI LARGHI CASSETTI, CONTIENE  
OGGETTI DIVERSI E, QUANDO SI AVVICINA  
AL FIANCO DEL LETTO, DIVENTA COMODINO.  
LINEE SOBRIE CHE SI VESTONO SEMPRE  
DI NUOVI COLORI.**

*CHEST OF DRAWERS WITH LARGE DRAWERS TO CONTAIN  
DIFFERENT OBJECTS. AT THE SIDE OF THE BED IT BECOMES  
A NIGHT TABLE. PLAIN LINES ALWAYS WEARING NEW COLORS.*

## CONTEMPORANEO

---

### **Comodini e Cassettiere**

*Night Tables and Chest of Drawers*

Aero	124
Taffy	126
Pyllon	130
Traccia	132

# Aero

DESIGN CRS HALIFAX

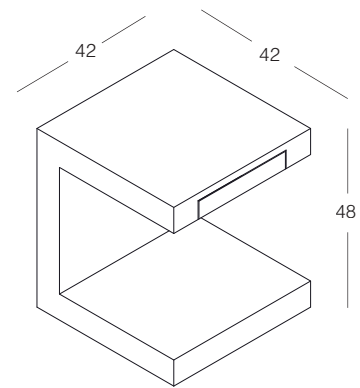
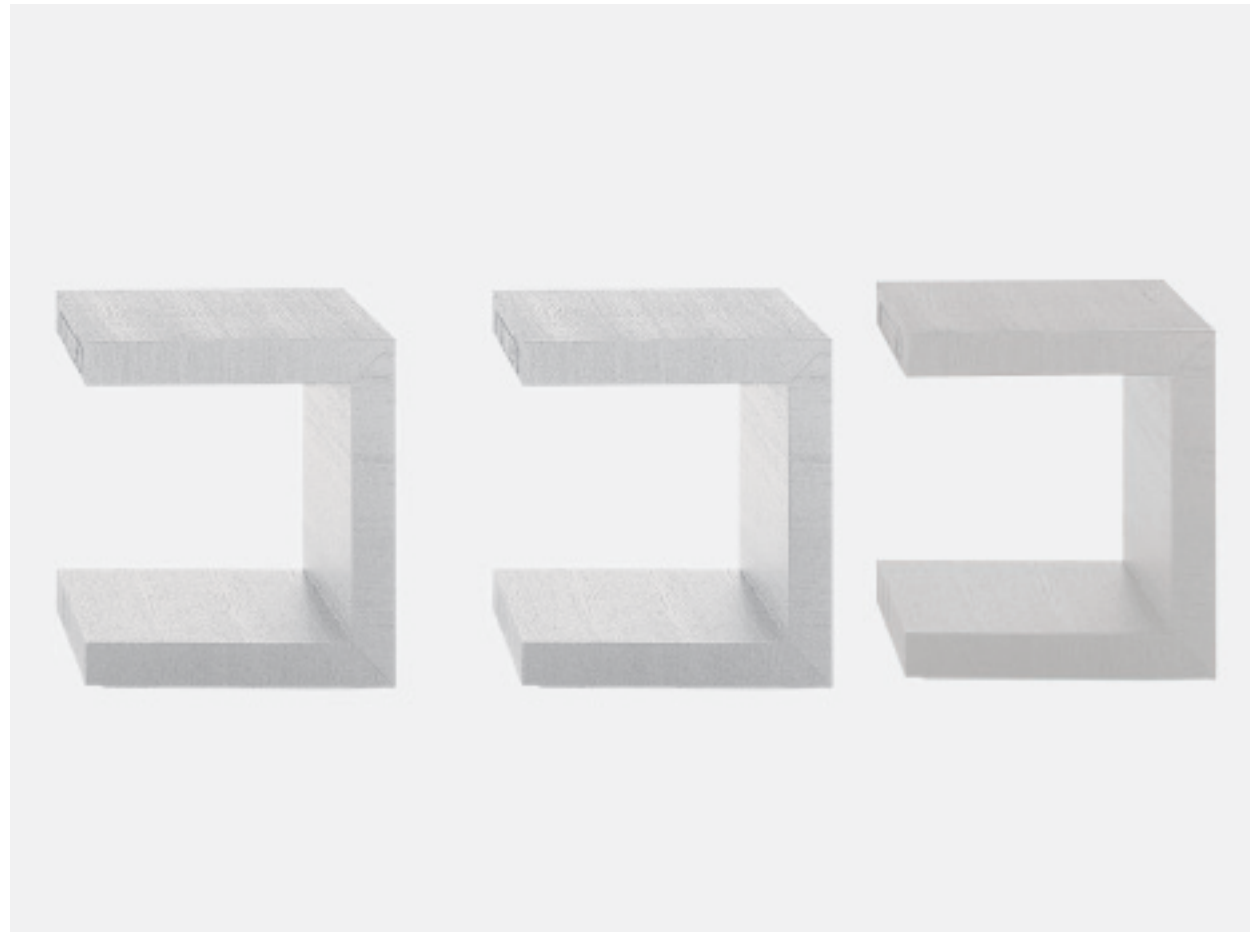

Comodino completamente in legno con cassetto inserito nel piano superiore.

*Night table fully constructed in veneered wood with drawer integrated in the upper top.*





# Taffy

DESIGN ENNIO AROSIO

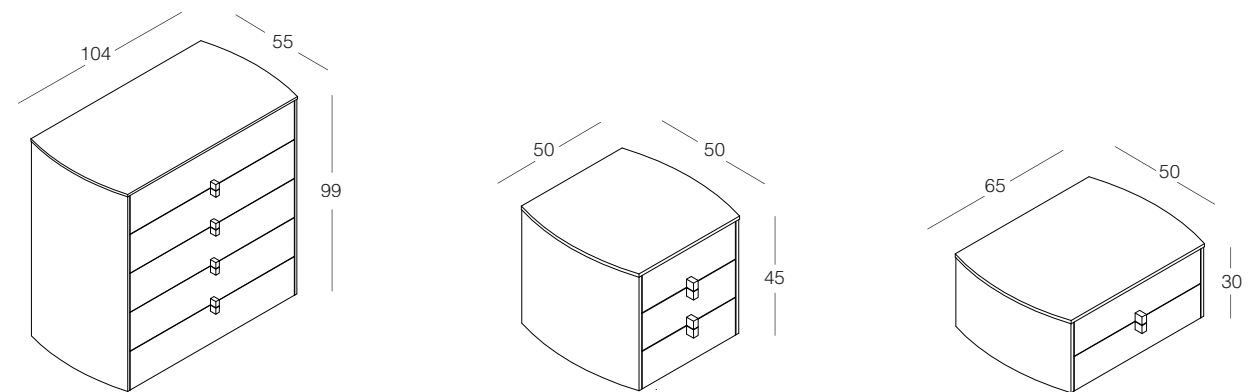

Serie contenitori in legno con fianchi sagomati, pomoli in metallo finitura canna di fucile.

Set of drawer elements in wood with rounded sides and metal handles finish canna di fucile.









# Pyllon

DESIGN ENNIO AROSIO

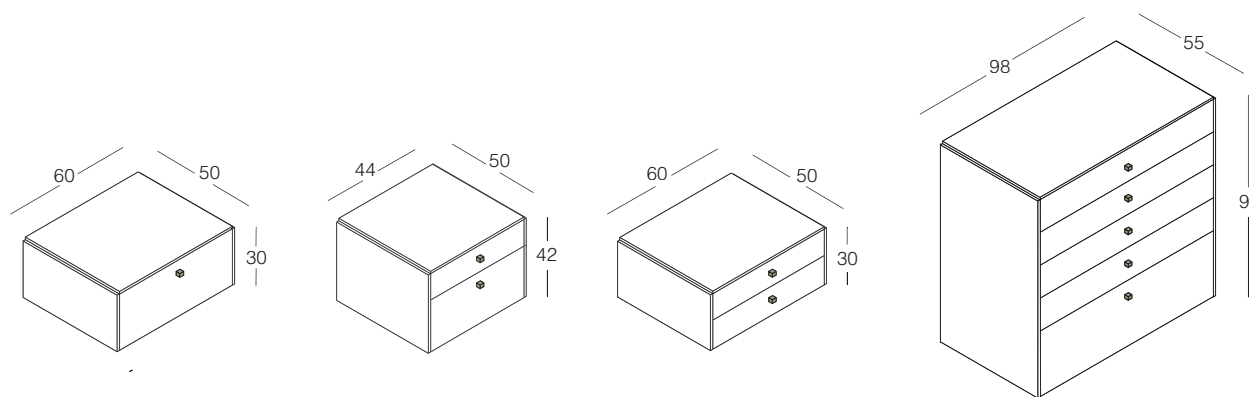

Serie contenitori in legno con pomoli in metallo finitura cannadi fucile.

Set of drawer elements in wood with metal handles finish canna di fucile.





# Traccia

DESIGN CRS HALIFAX

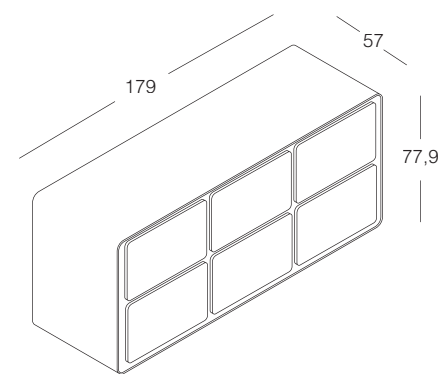
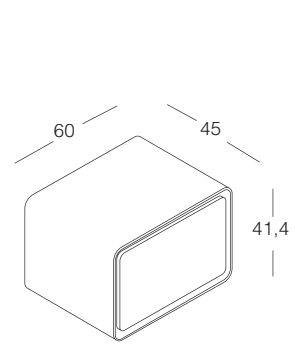

Serie contenitori eseguita in legno curvato con frontali cassetto laccati lucido. *Night table and chest of drawer in curved wood with drawer fronts finish glossy lacquer.*





**IL FASCINO ESERCITATO DA MANUFATTI  
DI PREGIO OPPORTUNITÀ DI VEDERE  
L'AMBIENTE CON UNA PROSPETTIVA  
NUOVA DEL TUTTO UNICA.**

*PRECIOUS OBJECTS GIVING TO THE ROOM A NEW  
AND ABSOLUTELY UNIQUE PERSPECTIVE.*

**CONTEMPORANEO**

---

**Specchi**

*Mirrors*

Imago	136
Tokyo	138
Venezia	140
Riflessi	142



# Imago

DESIGN MARCO BOGA

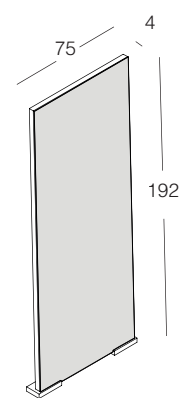

Specchio a terra con bordo perimetrale e piedini in legno. *Floor mirror with wooden edge and wooden feet.*





# Tokyo

DESIGN MARCO BOGA

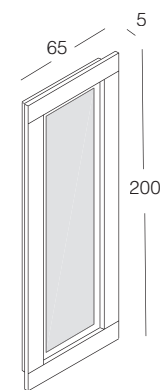

Specchio con cornice in legno.

Mirror with wooden frame.





# Venezia

DESIGN MARCO BOGA / CASSINA

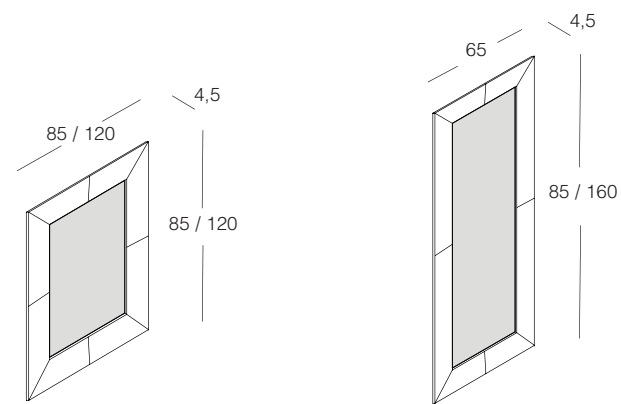

Specchio con cornice in legno nelle finiture foglia oro e foglia argento. *Mirror with wooden frame, gold and silver-foil finishes.*





# Riflessi

DESIGN MARCO BOGA

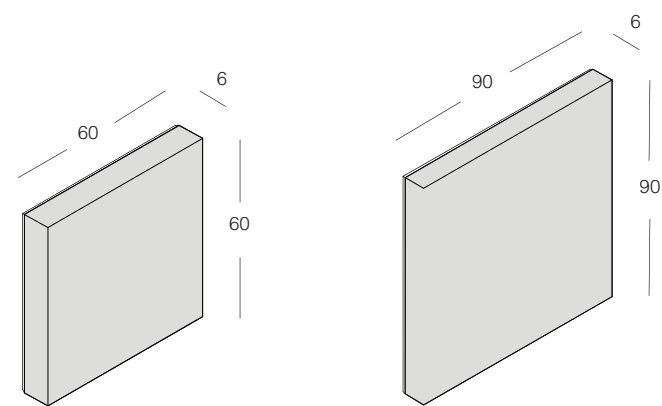

Specchio con bordo perimetrale finito a specchio.

*Mirror with mirror edges.*





**L'IMPRONTA, IL SEGNO DELL'ARTISTA  
CHE UTILIZZA MATERIALI, DANDO FORMA  
AD UN OGGETTO, ISPIRAZIONE DISTINTIVA  
DI ELEMENTI PRIMARI E SOSTANZIALI  
NELLA COLLEZIONE D'AUTORE, UNICI.**

*THE IMPRINTING, THE SIGN OF THE ARTIST MAKING USE  
OF MATERIALS, GIVING SHAPE TO AN OBJECT. ESSENTIAL  
ELEMENTS INSPIRING THE AUTHOR'S COLLECTION. UNIQUE.*

## COLLEZIONI D'AUTORE

### **Poltrone e Divani** *Armchairs and Sofas*

Serena	146
Feltrino	148
501	150
Intrecci poltrona	152
Intrecci divano	154
Intrecci collection 2-3-4 angolo	156
Luna di miele	158
Marilyn	160
Stealth	162
Boccaccio	164
Sartoriale	168





# Serena

DESIGN MARCO BOGA - ALESSANDRO GEDDA

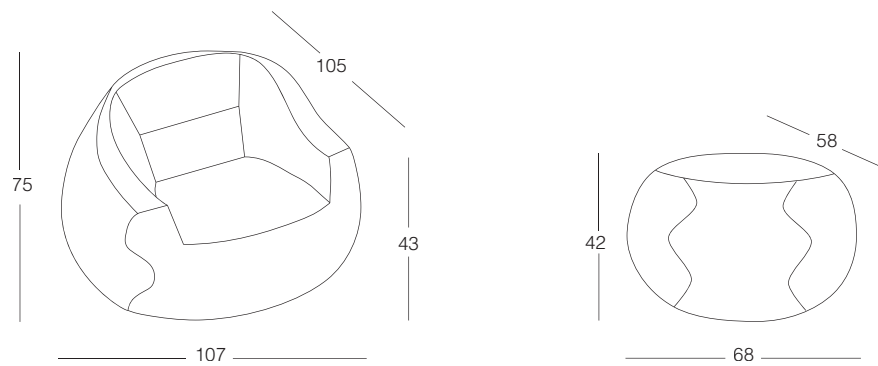

Poltrona con struttura in metallo annegato nel poliuretano con piastra girevole. Pouff in poliuretano espanso. Rivestimento in tessuto patchwork sfoderabile.

Armchair with metal structure embedded in polyurethane foam with swivel plate. Pouf in polyurethane foam. Removable cover in patchwork fabric.





# Feltrino

DESIGN MARCO BOGA - ALESSANDRO GEDDA

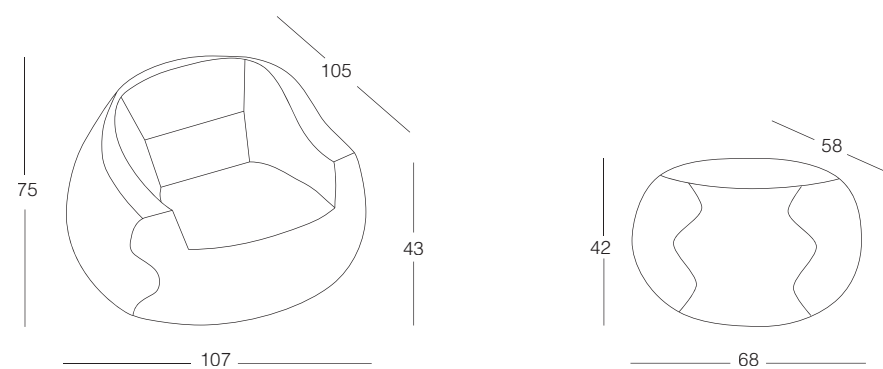

Poltrona con struttura in metallo annegato nel poliuretano con piastra girevole. Pouff in poliuretano espanso. Rivestimento in panno con impunture in contrasto sfoderabile.

*Armchair with metal structure embedded in polyurethane foam with swivel plate. Pouf in polyurethane foam. Removable cover in felt fabric with contrasting stitching.*





# 501

DESIGN MARCO BOGA - ALESSANDRO GEDDA

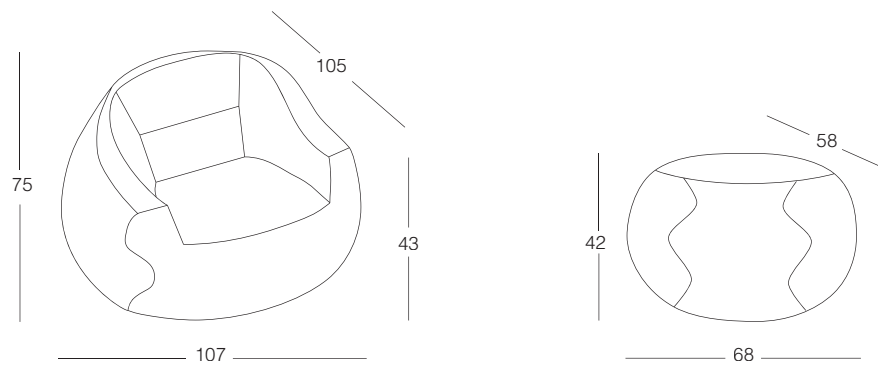

Poltrona con struttura in metallo annegato nel poliuretano con piastra girevole. Pouff in poliuretano espanso. Rivestimento in tagli di Denim sfoderabile.

Armchair with metal structure embedded in polyurethane foam with swivel plate. Pouf in polyurethane foam. Removable cover in cuts of denim fabric.





# Intrecci poltrona

DESIGN ALESSANDRO GEDDA

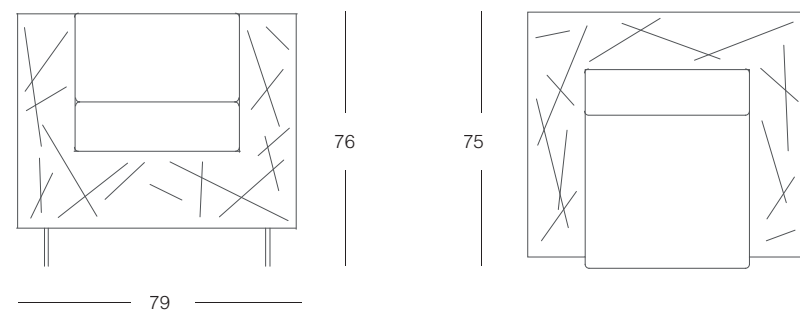

Poltrona destrutturata, realizzata con accostamenti e sovrapposizioni di listelli in legno massello. La casualità nell'applicazione dei listelli, realizzata interamente a mano, rende quest'opera un Masterpiece. Cuscino e schienale imbottiti. Rivestimento in tessuto sfoderabile cucitura con "Bordino" o in pelle sfoderabile cucitura doppio bordo accoppiato a vista.

*Unstructured armchair, made with combinations and overlapping of solid wood strips. The randomness in the application of the strips, made completely by hand, makes this a Masterpiece. Upholstered seat and back cushion. Removable fabric cover, seam with "Bordino" or non removable leather cover with double edge at sight.*





# Intrecci divano

DESIGN ALESSANDRO GEDDA

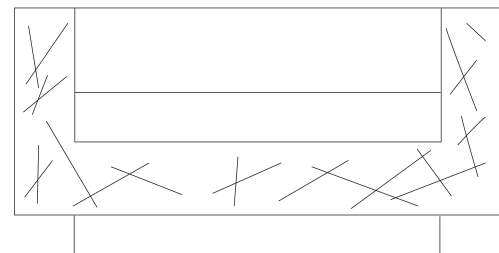

66

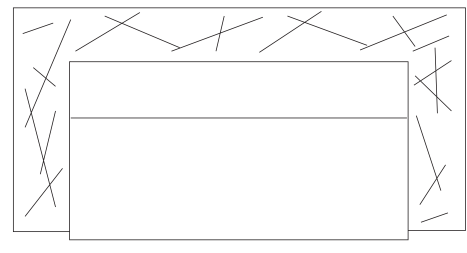

94

143 / 203 / 263

Divano destrutturato, realizzato con accostamenti e sovrapposizioni di listelli in legno massello. La casualità nell'applicazione dei listelli, realizzata interamente a mano, rende quest'opera un Masterpiece. Cuscino e schienale imbottiti. Rivestimento in tessuto sfoderabile cucitura con "Bordino" o in pelle sfoderabile cucitura doppio bordo accoppiato a vista.

*Unstructured sofa, made with combinations and overlapping of solid wood strips. The randomness in the application of the strips, made completely by hand, makes this a Masterpiece. Upholstered seat and back cushion. Removable fabric cover, seam with "Bordino" or non removable leather cover with double edge at sight.*

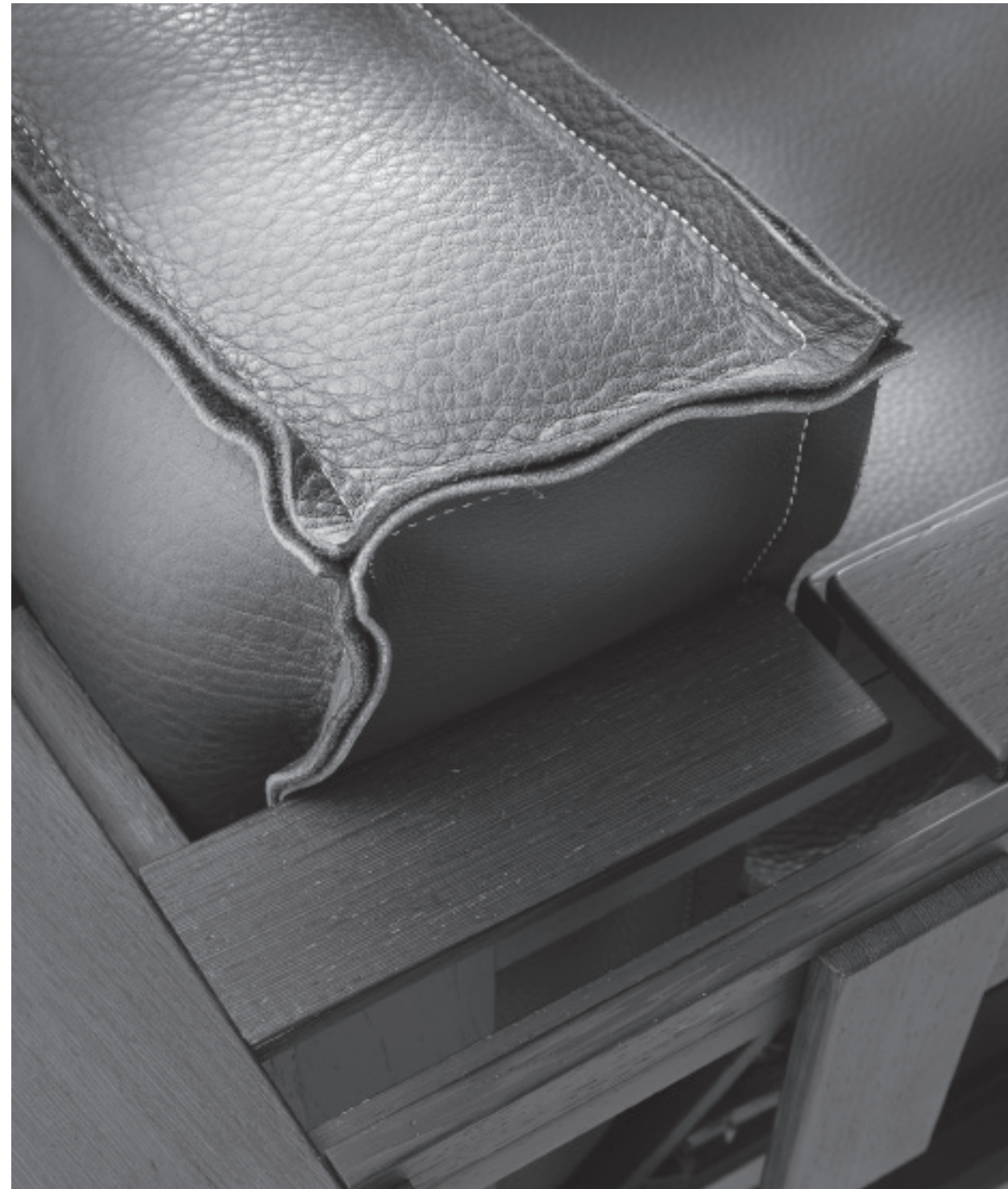



# Intrecci collection 2-3-4 angolo

DESIGN ALESSANDRO GEDDA

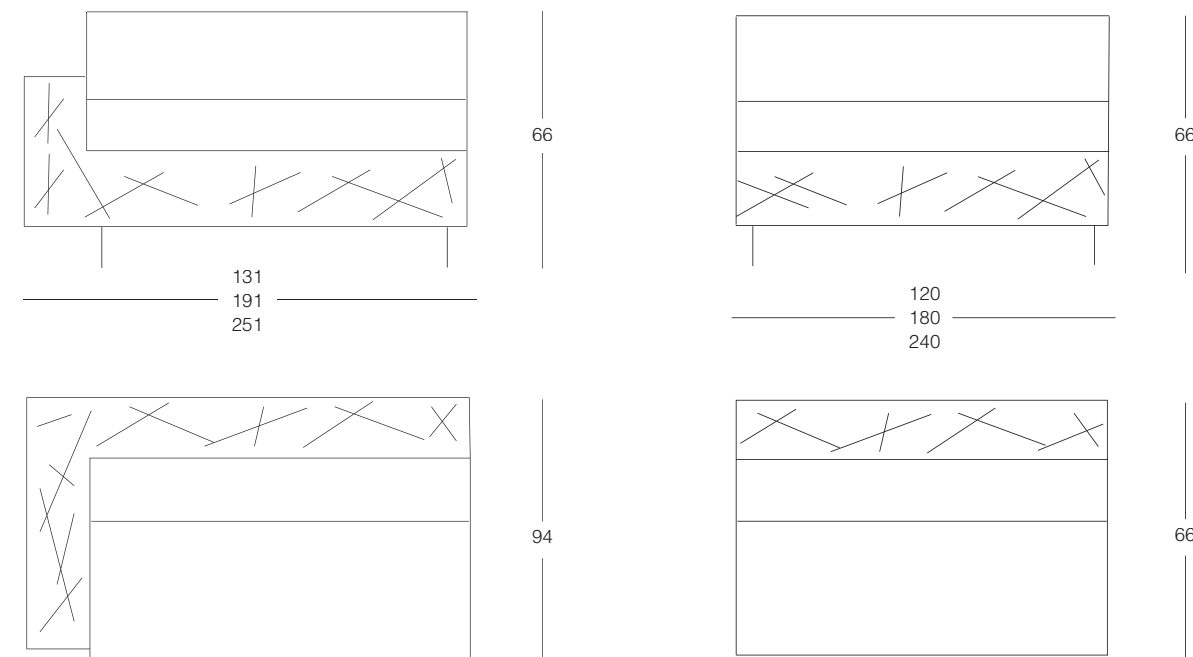

Sistema di sedute destrutturato, realizzato con accostamenti e sovrapposizioni di listelli in legno massello. La casualità nell'applicazione dei listelli, realizzata interamente a mano, rende quest'opera un Masterpiece. Cuscino e schienale imbottiti. Rivestimento in tessuto sfoderabile cucitura con "Bordino" o in pelle sfoderabile cucitura doppio bordo accoppiato a vista. Tavolino di raccordo triangolare.

*Unstructured seating system, made with combinations and overlapping of solid wood strips. The randomness in the application of the strips, made completely by hand, makes this a Masterpiece. Upholstered seat and back cushion. Removable fabric cover, seam with "Bordino" or non removable leather cover with double edge at sight. Connection triangular small table.*

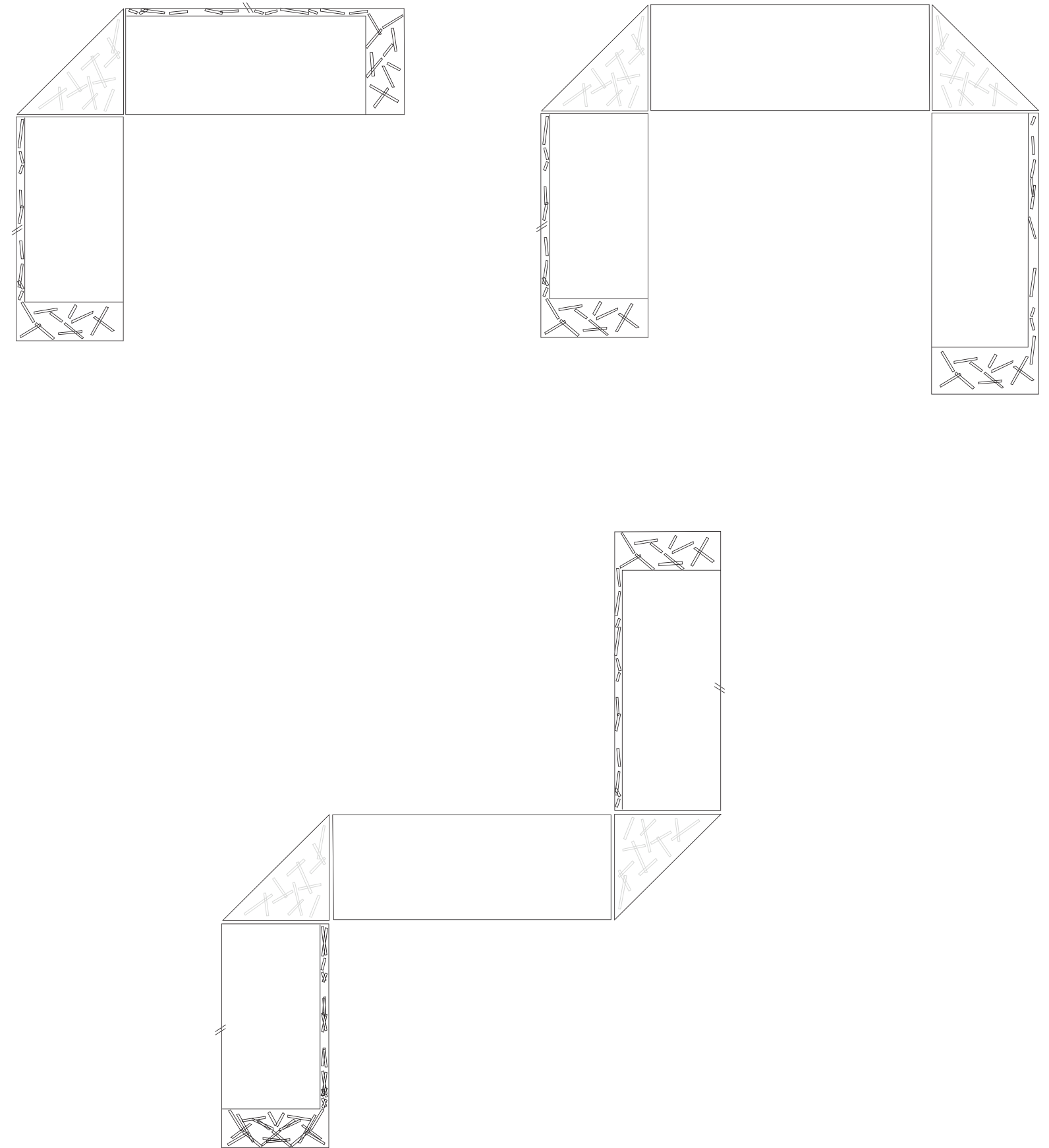



# Luna di miele

DESIGN ALESSANDRO GEDDA

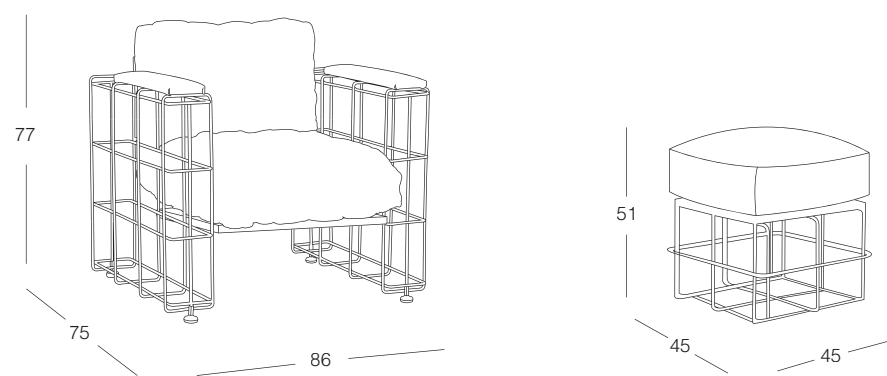

Poltrona con struttura in maglia di ferro, base e schienale in massello lamellare laccato nero.

Cuscino unico in schiuma simil spugna marina.

Armchair with structure in iron mesh, base and back multilayer panel, finish black lacquer.

Cushion in one piece, internal foam similar to sea-sponge.





# Marilyn

DESIGN ALESSANDRO GEDDA



Divano componibile con base in acciaio, sedute rivestite in pelle Nabuk, schienale rialzato e piedini rivestiti in volpe.

*Modular sofa with steel base frame, seating covered with non removable Nabuk leather, raised back and feet covered with fox fur.*





# Stealth

DESIGN ALESSANDRO GEDDA



Divano a segmenti irregolari con struttura in legno rivestito in poliuretano espanso a densità differenziata, cuscini in poliuretano espanso. Rivestimento in tessuto parzialmente sfoderale.

*Sofa with irregular segments, wooden frame covered with different density polyurethane foam, cushions in polyurethane foam. Partially removable fabric cover.*





# Boccaccio

DESIGN CRS HALIFAX - ALESSANDRO GEDDA



Divano componibile con struttura in legno rivestita in poliuretano a densità differenziata. Cuscino schienale in piuma con inserto in poliuretano. Rivestimento in panno con impunture in contrasto sfoderabile.

*Modular sofa with wooden frame covered with different density polyurethane foam. Backrest cushion in feather with polyurethane internal support. Removable cover in felt fabric with contrasting stitching.*









# Sartoriale

DESIGN CRS HALIFAX - ALESSANDRO GEDDA



Sistema di sedute con struttura in legno rivestito in poliuretano espanso a densità differenziata. Cuscini sedile e schienale in poliuretano espanso. Rivestimento fisso in pelle piumone con impunture a contrasto. Piedini e retroschiena in metallo finitura canna di fucile.

*Seating system with wooden frame covered with different density polyurethane foam. Seat and back cushions in polyurethane foam.*

*Non removable piumone leather cover with contrasting stitching. Metal feet and back bar finish canna di fucile.*





Marilyn

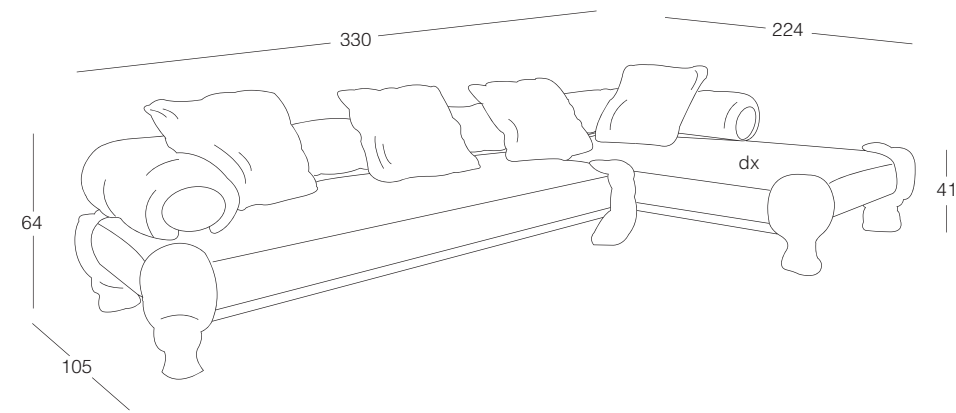

Stealth

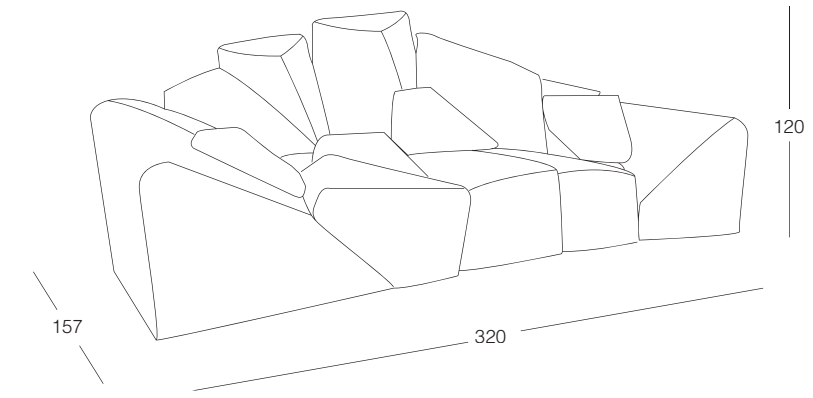



Boccaccio

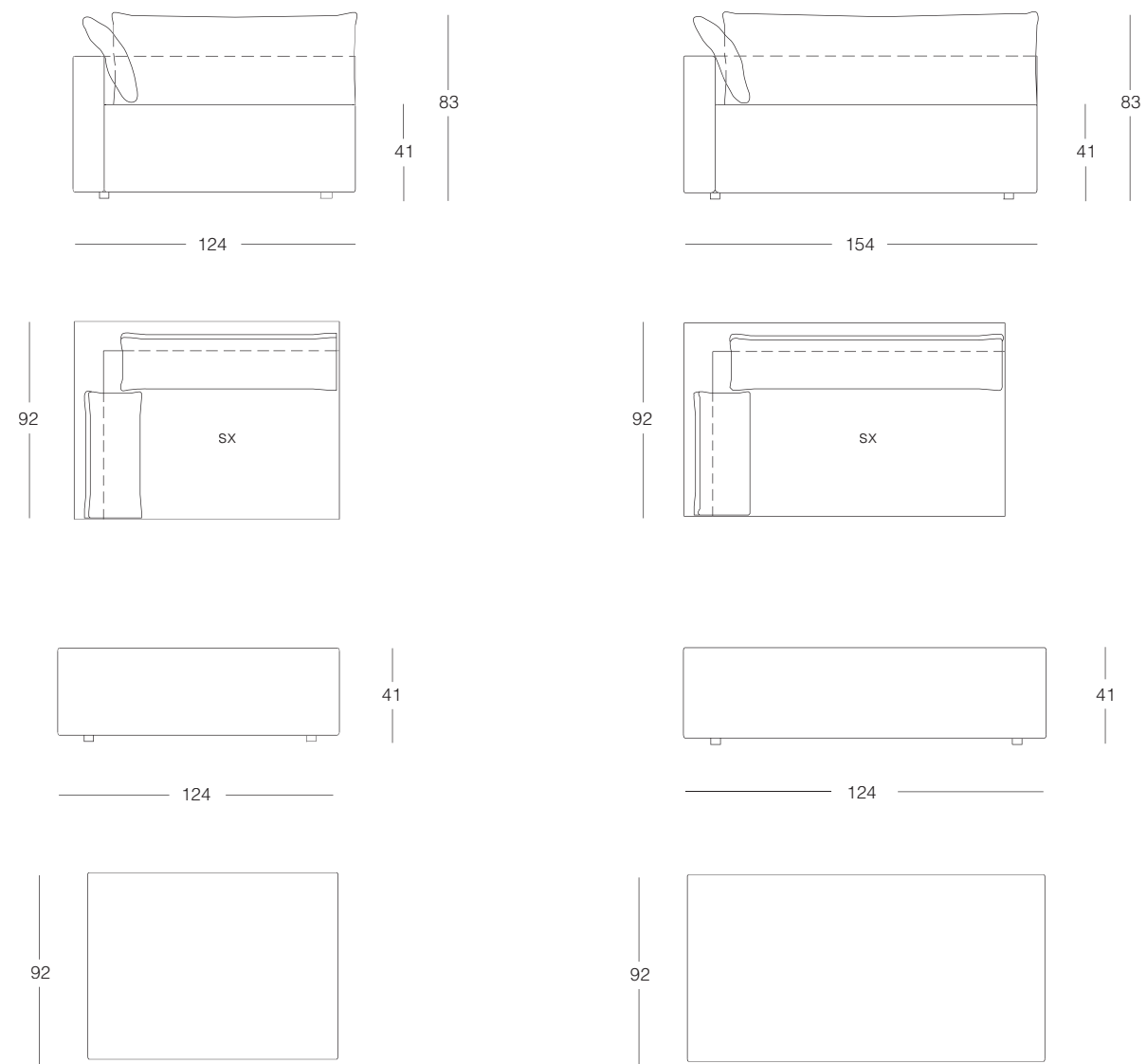

Sartoriale

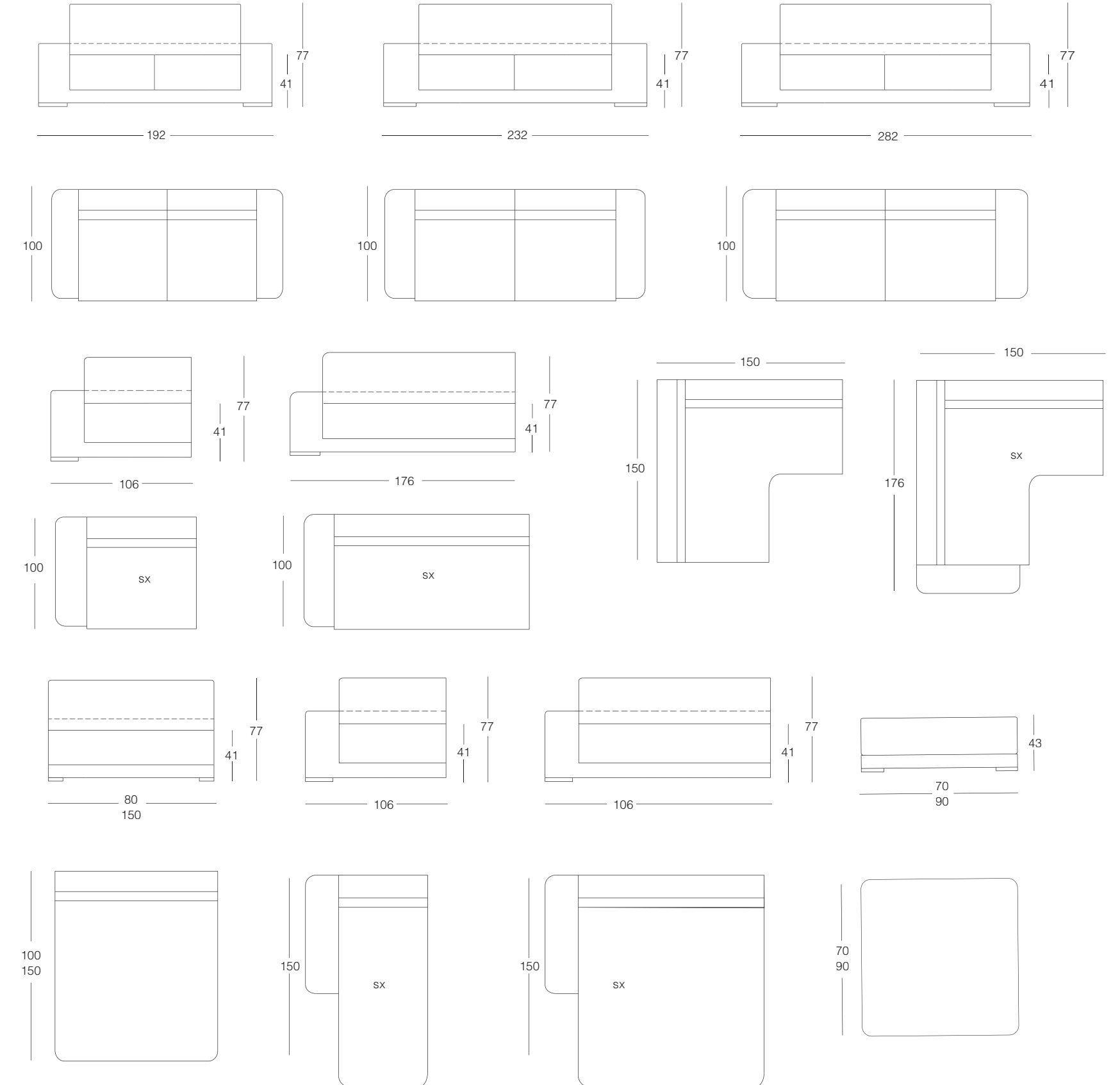



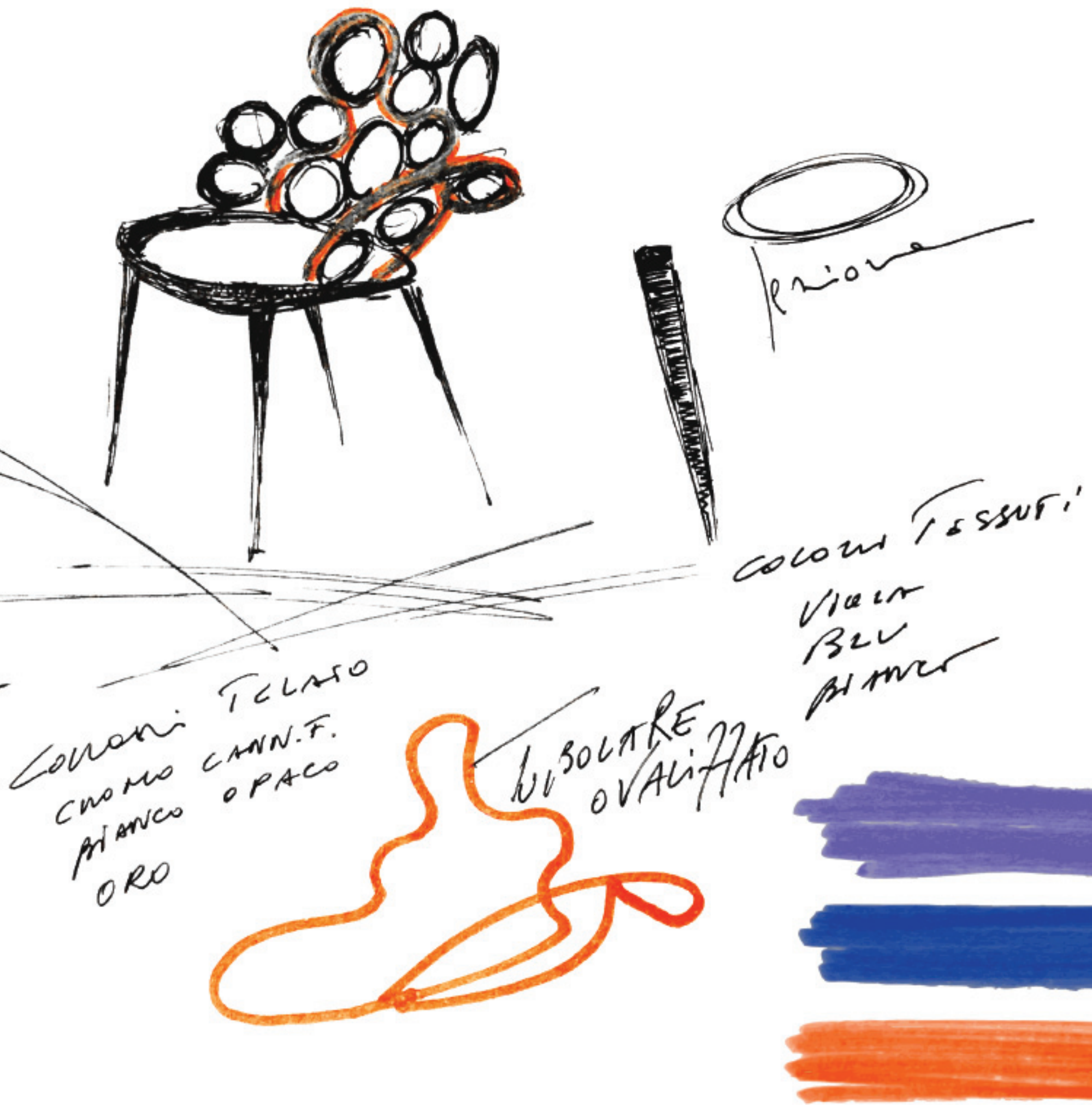



# Annette

DESIGN STUDIO SIGLA - ALESSANDRO GEDDA

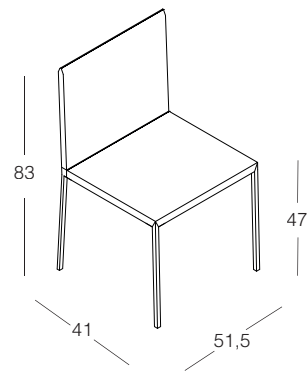

Sedia con struttura in profilato d'acciaio annegato nel poliuretano rivestita in cavallino, gambe in metallo finitura canna di fucile.

*Chair with metal structure embedded in polyurethane foam covered with pony leather, metal legs finish canna di fucile.*





## COLLEZIONI D'AUTORE

---

### **Tavoli e Tavolini** *Tables and Coffee Tables*

Righetta	180
Ivory - Black Swan fisso	182
Ivory - Black Swan 300	184
Ivory - Black Swan tavolino	186
Intrecci 9.9	190



# Righetta

DESIGN CRS HALIFAX - ALESSANDRO GEDDA

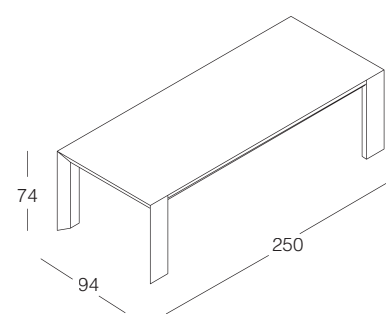
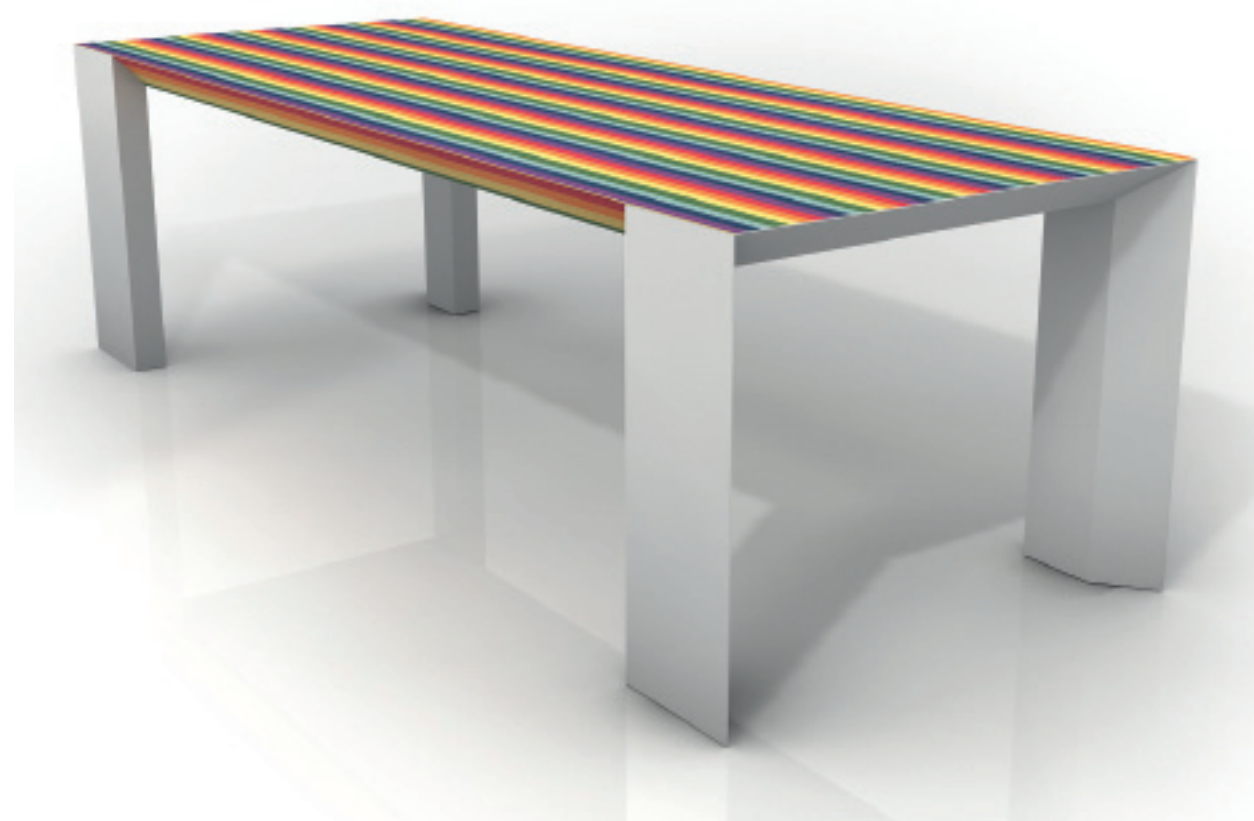

Tavolo rettangolare con gambe e piano in legno.  
Gambe laccate bianco opaco, piano in legno ricomposto  
multicolor.

*Rectangular table with wooden top and legs.  
White mat lacquered legs, top in multicolor recomposed  
wood.*





# Ivory - Black Swan fisso

DESIGN LA MENSA - ALESSANDRO GEDDA

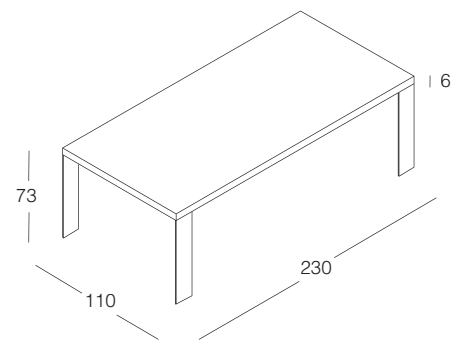

Tavolo rettangolare con piano in legno di forte spessore e gambe in metallo finitura canna di fucile.

*Rectangular table with a thick wooden top and metal legs finish canna di fucile.*





# Ivory - Black Swan 300

DESIGN LA MENSA - ALESSANDRO GEDDA

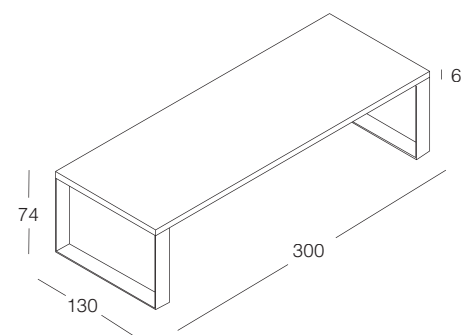

Tavolo rettangolare con piano in legno di forte spessore e gambe in metallo finitura canna di fucile.

Rectangular table with a thick wooden top and metal legs finish canna di fucile.





# Ivory - Black Swan tavolino

DESIGN LA MENSA - ALESSANDRO GEDDA

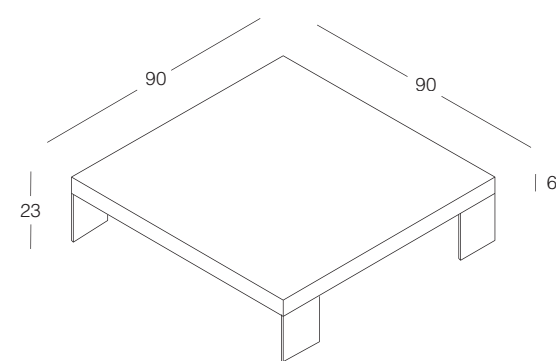

Tavolo basso con piano in legno e gambe in metallo  
finitura canna di fucile.

*Coffee table with a thick wooden top and metal legs  
finish canna di fucile.*









# Intrecci 9.9

DESIGN ALESSANDRO GEDDA

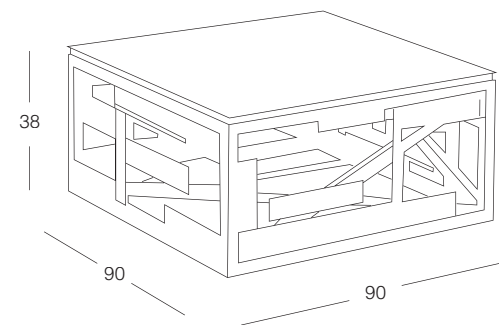

Tavolino destrutturato, realizzato con accostamenti e sovrapposizioni di listelli in legno massello.

*Unstructured coffee table, made with combinations and overlapping of solid wood strips.*





## COLLEZIONI D'AUTORE

---

### **Contenitori e Librerie** *Storage Units and Bookcases*

Taglia e cucì	194
Ivory	196
Network	198



# Taglia e cuci

DESIGN ALESSANDRO GEDDA

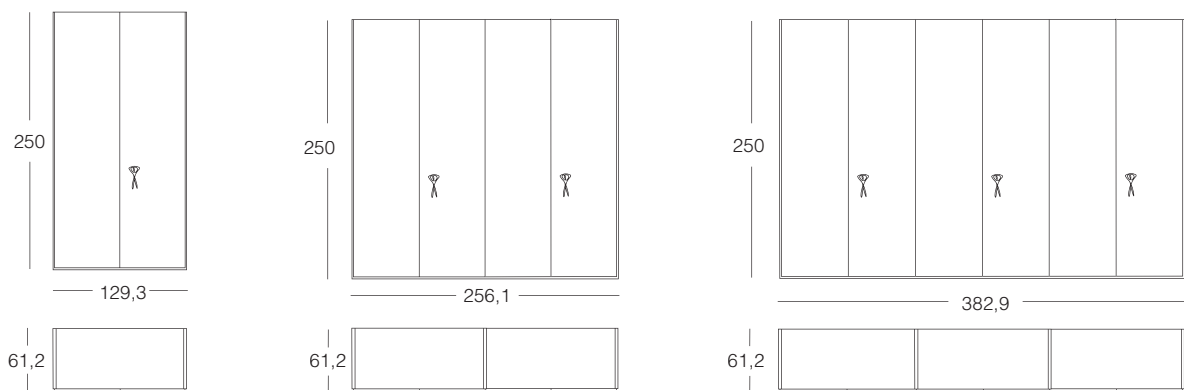

Contenitore con ante in legno ricomposto effetto gessato, una maniglia sartoriale, interni in colore, schienale a specchio.

*Storage unit with wooden doors in recomposed veneer finish gessato, a tailoring handle, equipments in colour finish, mirror back panel.*





# Ivory

DESIGN ENRICO FRANZOLINI - ALESSANDRO GEDDA

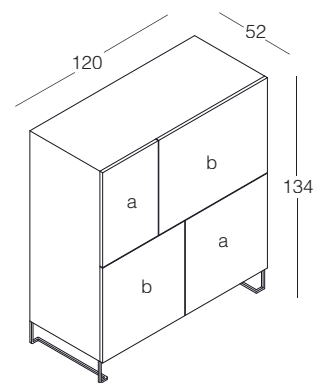

Contenitore in legno con struttura laccata nero e quattro ante in essenza ebano bianco. Piedini in metallo finitura canna di fucile.

*Wooden storage unit with black lacquered structure and four doors in white ebony. Metal feet finish canna di fucile.*





# Network

DESIGN ALESSANDRO GEDDA

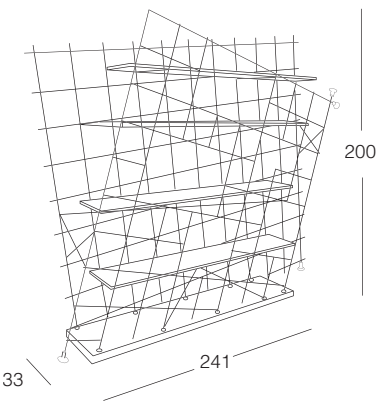
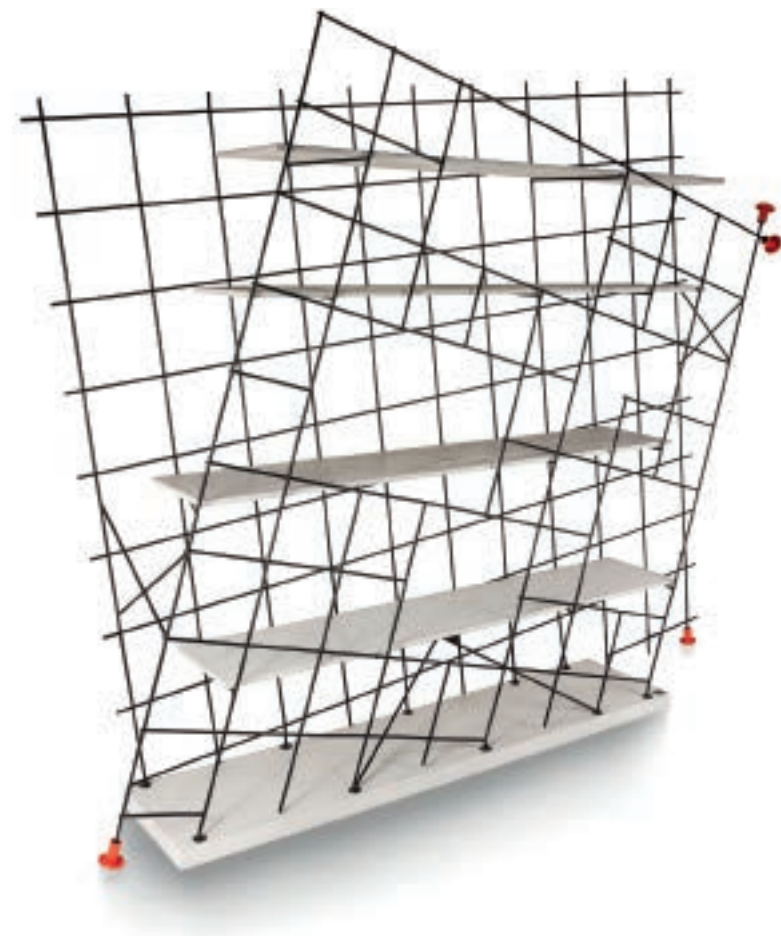

Libreria con struttura in maglia di ferro, base e piani in alluminio alveolare finitura cemento.

*Bookcase with iron mesh structure, base and shelves in alveolar aluminium cement finish.*





## COLLEZIONI D'AUTORE

---

### **Letti**

#### *Beds*

Le pieghe 202

Atelier 206



# Le pieghe

DESIGN ALESSANDRO GEDDA



Letto con testata e pediera imbottite. Rivestimento in pelle Nabuk fisso.

Bed with upholstered headboard and footboard. Covered with non removable Nabuk leather.









# Atelier

DESIGN CRS HALIFAX - ALESSANDRO GEDDA

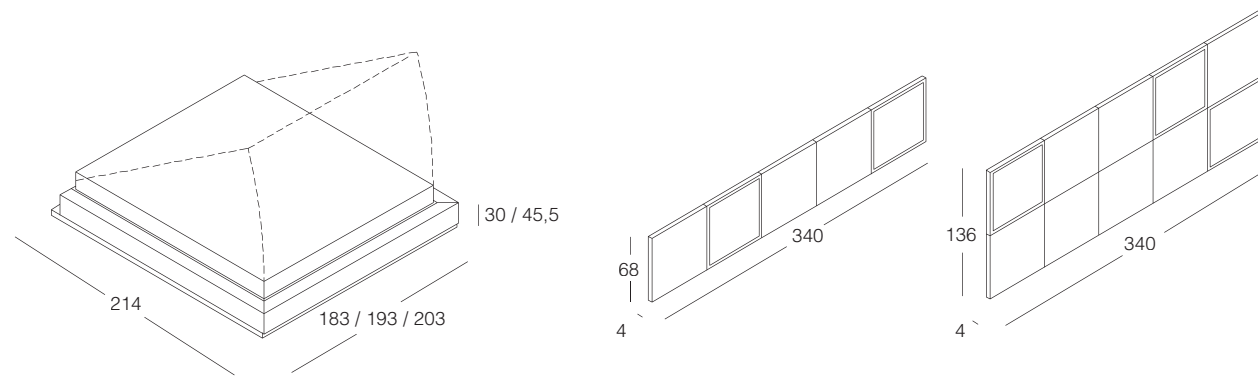

Letto con contenitore, con testata a pannelli e base imbottita. Rivestimento in pelle fisso con impunture a contrasto.

Storage bed with panels headboard and padded base. Non removable leather cover with contrasting stitching.





## COLLEZIONI D'AUTORE

---

### **Comodini e Cassettiere**

*Night Tables and Chests of drawers*

Le pieghe

210



# Le pieghe

DESIGN ALESSANDRO GEDDA



Comodino con base in metallo e piano in legno, rivestito in pelle Nabuk fisso e piano in appoggio in vetro.

Night table with metal base and wooden top, covered with non removable Nabuk leather and overlaid glass top.

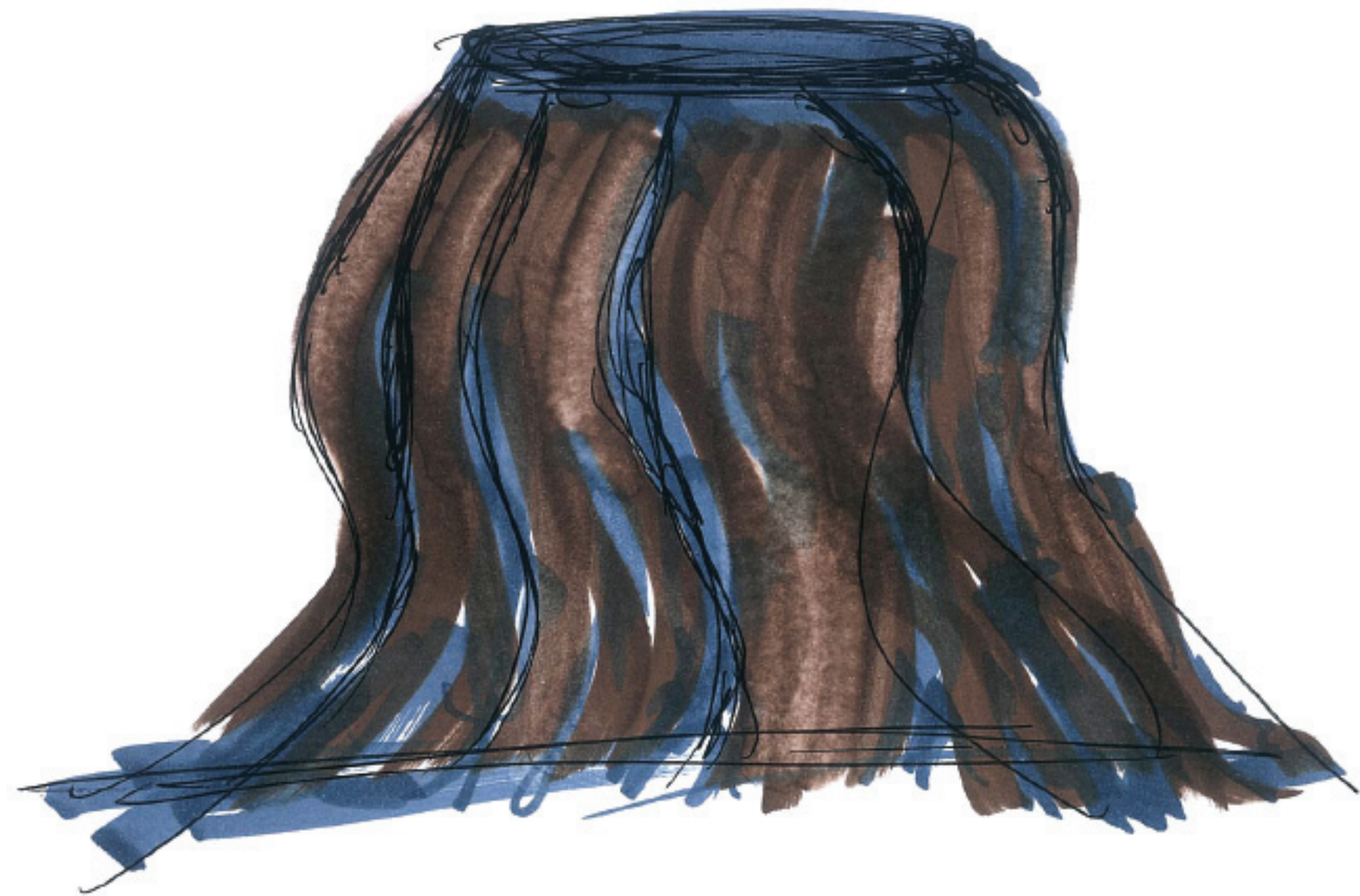



## COLLEZIONI D'AUTORE

---

### **Specchi e Appendiabiti** *Mirrors and Cloth-hangers*

Pittura fresca	214
Macchia	216
Righetta Specchio	218
Gessato Specchio	219



# Pittura fresca

DESIGN ALESSANDRO GEDDA

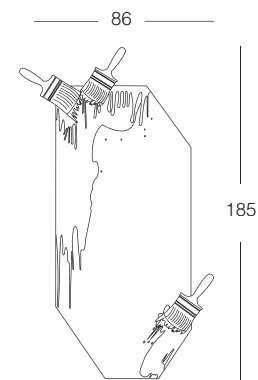
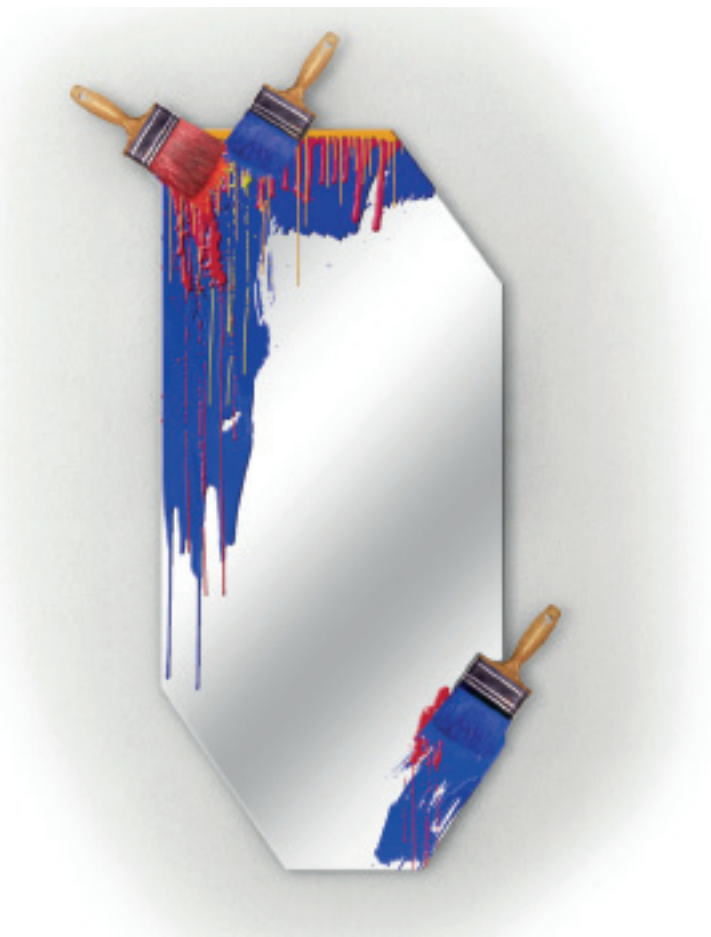

Specchio a muro con applicazioni di pennelli e macchie di colore. *Wall mirror decorated with paint brushes and colour spots.*





# Macchia

DESIGN ALESSANDRO GEDDA

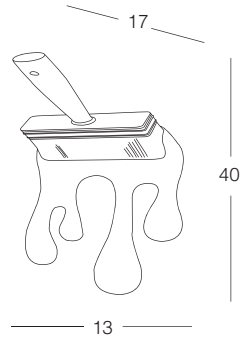

Appendiabiti da parete disponibile in vari colori.

Wall cloths hanger available in various colours.



# Righetta Specchio

DESIGN MARCO BOGA - ALESSANDRO GEDDA

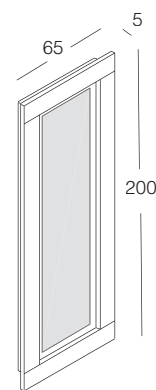

Specchio con cornice rivestita in legno ricomposto multicolor. *Mirror with frame finish multicolor recomposed wood.*

# Gessato Specchio

DESIGN MARCO BOGA - ALESSANDRO GEDDA

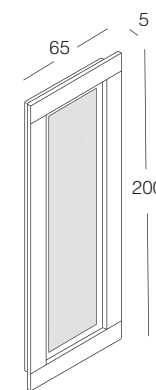

Specchio con cornice rivestita in legno ricomposto effetto gessato. *Mirror with frame finish gessato recomposed wood.*



**LEGNI, PLASTICA E FIBRA DI VETRO,  
SI DISTINGUONO TRA I MATERIALI SEMPLICI  
O COMPOSITI, CHE RICHIAMANO LA  
TRADIZIONE E L'AVANGUARDIA, ROMPENDO  
GLI SCHEMI DELLA CULTURA DELL'OUTDOOR.**

*WOOD, PLASTIC, GLASS FIBRE ARE AMONG THE SIMPLE  
OR COMPOSITE MATERIALS EVOKING TRADITION  
AND AVANT-GARDE, PROPOSING AN UNCONVENTIONAL  
PROFILE OF THE OUTDOOR CULTURE*

## OUTDOOR

---

Casper	222
Casper sofa	224
Casper chaise longue	226
Art Apple	227
Adamo&Eva	228
Nu.Ovo	230



# Casper

DESIGN ALESSANDRO GEDDA

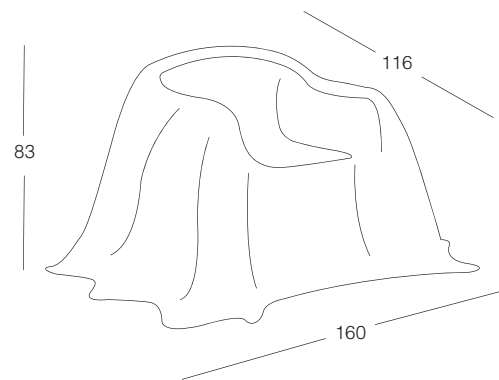

Poltrona monoscocca realizzata con materiale composito in VTR. Ideale in ambiente outdoor, adatto anche in interni. Finitura laccato lucido colore.

*Monocoque armchair made of composite material VTR. Perfect for both outdoor and indoor. Glossy colour lacquer finish.*





# Casper sofa

DESIGN ALESSANDRO GEDDA

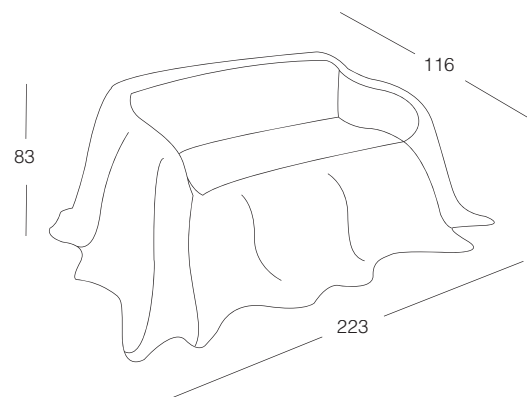

Divano monoscocca realizzato con materiale composito in VTR. Ideale in ambiente outdoor, adatto anche in interni. Finitura laccato lucido colore.

*Monocoque sofa made of composite material VTR. Perfect for both outdoor and indoor. Glossy colour lacquer finish.*





# Casper chaise longue

DESIGN ALESSANDRO GEDDA

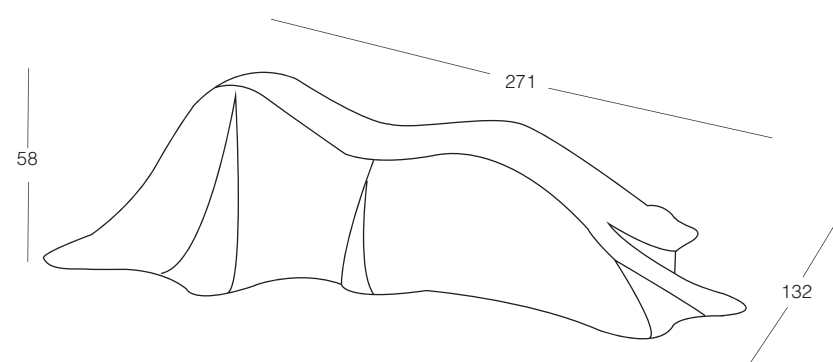

Chaise Longue monoscocca realizzata con materiale composito in VTR. Ideale in ambiente outdoor, adatto anche in interni. Finitura laccato lucido colore.

*Monocoque chaise longue made of composite material VTR. Perfect for both outdoor and indoor use. Glossy colour lacquer finish.*

# Art Apple

DESIGN ALESSANDRO GEDDA

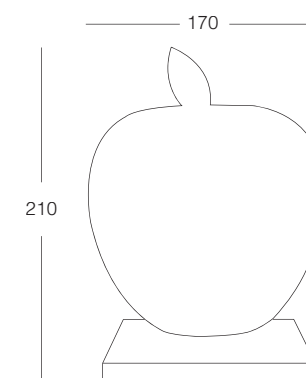

Sculptura a forma di mela realizzata con materiale composito in VTR. Ideale in ambiente outdoor, adatto anche in interni. Finitura laccato lucido colore.

*Sculpture with the shape of apple made of composite material VTR. Perfect for both outdoor and indoor. Glossy colour lacquer finish.*



# Adamo&Eva

DESIGN ALESSANDRO GEDDA

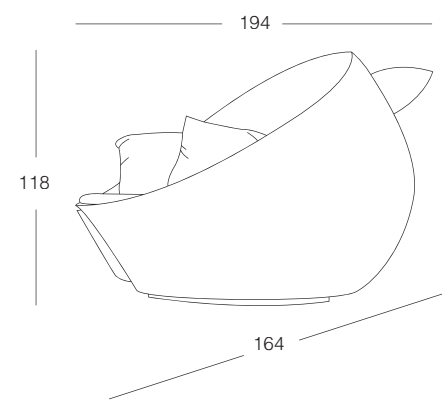

Divano monoscocca girevole realizzato con materiale composito in VTR. Seduta e cuscini imbottiti e rivestiti in tessuto sfoderabile. Ideale in ambiente outdoor, adatto anche in interni. Finitura laccato lucido colore.

*Monocoque swivel sofa made of composite material VTR. Seating and cushions padded and covered with removable fabric. Perfect for both outdoor and indoor. Glossy colour lacquer finish.*





# Nu•Ovo

DESIGN PAOLO MALDOTTI

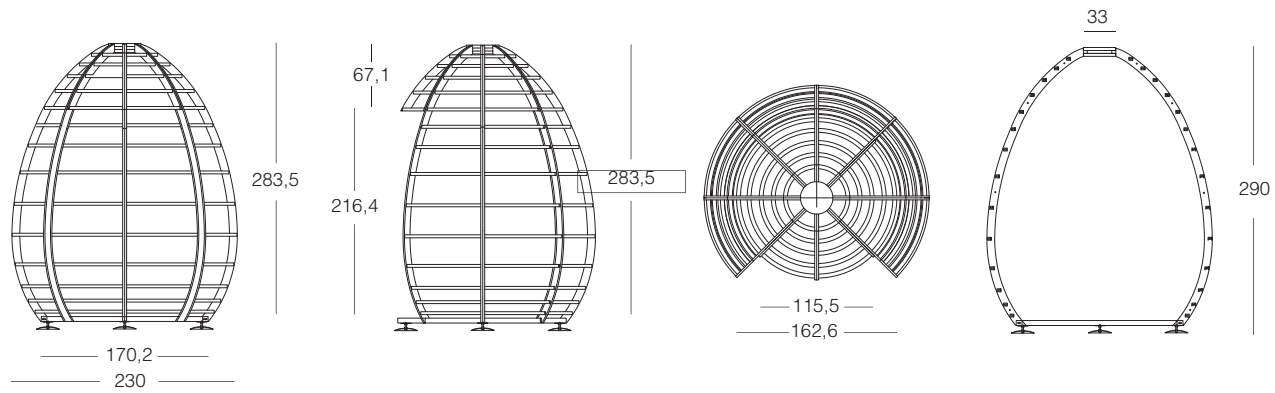

Nuova unità di misura dell'attività umana per creare nuovi ambienti negli ambienti. Una cellula abitativa polifunzionale da attrezzare a piacimento, pensata per la dimensione pubblica o privata, sia indoor che outdoor.

*The new unit of measurement of the human activity to create new rooms inside other rooms. A multifunctional house unit to fit out as you like, thought for the public and private dimension both indoor and outdoor.*





*ma non i coperti*









# COLOPHON

---

**Designers**

Alessandro Gedda, Antonello Mosca,  
Antonio Citterio, Carlo Bartoli, Daniele Lo Scalzo  
Moscheri, Ennio Arosio, Enrico Franzolini,  
Fabrizio Zappa, Giuseppe Viganò, La Mensa,  
Marco Boga, Mauro Lipparini, Mirto Zocca,  
Paolo Maldotti, Piva Associati, Riccardo  
Arbizzoni, Vittorio Prato.

**Graphic project**

Take Srl - Milano

**Graphic designer**

Anna Tortora

**Photo**

Fabrizio Fenucci, archivio Halifax

**Stylist**

Silvia Panceri

**Copy**

Manuela De Carli

**Print**

Grafiche Boffi - Giussano

**HALIFAX**

*since 1991*

Via Tofane, 37  
20833 Giussano (MB)  
T. +39 0362 3191  
info@halifaxgroup.it  
www.halifaxgroup.it