

**HALIFAX**

*Since 1991*

---

Halifax è un marchio storico, nato negli anni '90 nel cuore della Brianza, culla di sapienti artigiani e del manufatto artigianale, grazie alla straordinaria sapienza nell'arte della lavorazione del legno, alla selezione dei materiali migliori, ha realizzato e realizza ancora oggi un prodotto curato nel dettaglio e dalle pregiate finiture.

La nostra attenzione è sempre stata quella di trasformare la materia in un oggetto funzionale ma al contempo di design. Halifax nasce con prodotti realizzati in massello di legno dal sapore della memoria, ne sono l'esempio il tavolo Winston, la vetrina Vetriera, l'espositore Bacheca, che oggi, dopo 25 anni, riproponiamo con legni alternativi come "cultura del bello" e salvaguardia di soluzioni uniche e di grande personalità.

L'identificazione del made in Italy viene altresì distinta nello stile del contemporaneo, nella stravagante ricercatezza del prodotto d'autore, regalando ad ogni ambiente carattere e autenticità.

---

*Halifax is a historic brand, born in the 90's at the heart of Brianza, cradle of master craftsmen, manufacturers of amazing hand-crafted works thanks to their skill in selecting the best materials and their advanced know-how in woodwork. Halifax always manufactured, during the years till nowadays, a highly refined product, extremely accurate in details and in the choice of the most precious finishes.*

*Our attention always focused on transforming the material into a functional object and a design object at the same time. Halifax initial collection offers a range of products manufactured in solid wood, with hints of memory, like the table Winston, the vitrine Vetriera and the showcase Bacheca. After 25 years we are re-proposing these items with alternative woods. Our heritage of beauty and unique solutions characterized by a strong personality.*

*The Made in Italy identifies with the style of Contemporaneo and with the inspired elegance of Collezione d'Autore, giving to each room character and authenticity.*

## LE MEMORIE

Ginevra	8
Isotta	10
Winston	12
Vassoia	14
Espositore console	16
Cassettaio	18
Bacheca	20
Vetriera	22



## CONTEMPORANEO

### Poltrone e Divani *Armchairs and sofas*

Bubble e pouff	28
Double	30
Kompasso	32
Point	34
Ambrogio	36
Blade	40
Cover	44
Lama	46

### Sedie *Chairs*

Minni sedia	54
Minni sgabello	56
Teodolinda	58
Hosteria	62

### Tavoli e Tavolini *Tables and Coffee Tables*

Ulisse	66
Vittorio fisso	68
Vittorio 300	70
Nodo	72
Hosteria	74
Carpenter	76
Mirto	78
Vittorio tavolino	80
Quadro	82
Naos	84
Art - Art Light	86
Swing	88



### Contenitori e Librerie *Storage Units and Bookcases*

Lisboa	92
Half Lisboa	96
Extra	98
Achille	100
Square	102

### Letti *Beds*

Ania	106
Karma	108
Thai	110
Taffy	114
Nikka	116
Japo	118
Quito	120

### Comodini e Cassettiere *Night Tables and Chests of Drawers*

Aero	124
Taffy	126
Pyllon	130
Traccia	132

### Specchi *Mirrors*

Imago	136
Tokyo	138
Venezia	140
Riflessi	142



## COLLEZIONI D'AUTORE

### Poltrone e Divani *Armchairs and sofas*

Serena	146
Feltrino	148
501	150
Intrecci poltrona	152
Intrecci divano	154
Intrecci collection 2-3-4 angolo	156
Luna di miele	158
Marilyn	160
Stealth	162
Boccaccio	164
Sartoriale	168

### Sedie *Chairs*

Annette	176
---------	-----

### Tavoli e Tavolini *Tables and Coffee Tables*

Righetta	180
Ivory - Black Swan Fisso	182
Ivory - Black Swan 300	184
Ivory - Black Swan tavolino	186
Intrecci 9.9	190



### Contenitori e Librerie *Storage Units and Bookcases*

Taglia e cuci	194
Ivory	196
Network	198

### Letti *Beds*

Le pieghe	202
Atelier	206

### Comodini e Cassettiere *Night Tables and Chests of Drawers*

Le pieghe	210
-----------	-----

### Specchi e Appendiabiti *Mirrors and Cloth-Hangers*

Pittura fresca	214
Macchia	216
Righetta Specchio	218
Cessato Specchio	219

## OUTDOOR

Casper	222
Casper sofa	224
Casper chaise longue	226
Art Apple	227
Adamo&Eva	228
Nu•Ovo	230



**CONSERVANO, RICREANO  
E RICOSTRUISCONO UN OGGETTO  
CHE È STATO CAPACE DI PROGETTARE  
IL FUTURO. IL TATTO E L'OLFATTO  
PER RITORNARE ALLE RADICI  
ALL'ORIGINALE IDENTITÀ.**

*MEMORIES PRESERVING, RECREATING AND  
RECONSTRUCTING A PRIOR OBJECT, ABLE TO PLAN  
THE FUTURE. THE SENSES OF SMELL AND TOUCH  
TO GO BACK TO THE ROOTS OF THE ORIGINAL IDENTITY.*

## LE MEMORIE

---

Ginevra	8
Isotta	10
Winston	12
Vassoia	14
Espositore console	16
Cassettaio	18
Bacheca	20
Vetriera	22



# Ginevra

DESIGN ENRICO FRANZOLINI - ALESSANDRO GEDDA

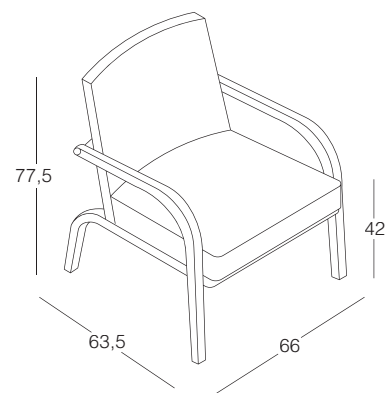

Poltrona con struttura in massello. Sedile e schienale imbottito e rivestito con tessuto sfoderabile.

*Armchair with structure in solid wood. Seat and back padded and covered with removable fabric.*





# Isotta

DESIGN CRS HALIFAX - ALESSANDRO GEDDA

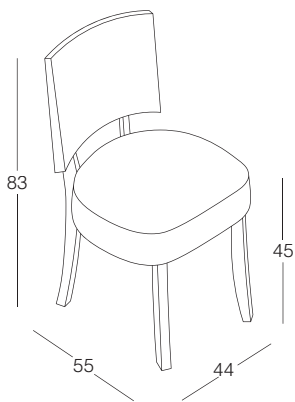

Sedia, struttura in massello, schienale in compensato curvato. Sedile imbottito e rivestito in tessuto sfoderabile. *Chair with structure in solid wood, back in curved multi-layer. Seat padded and covered with removable fabric.*





# Winston

DESIGN MARIANNE DAY LEWIS - ALESSANDRO GEDDA

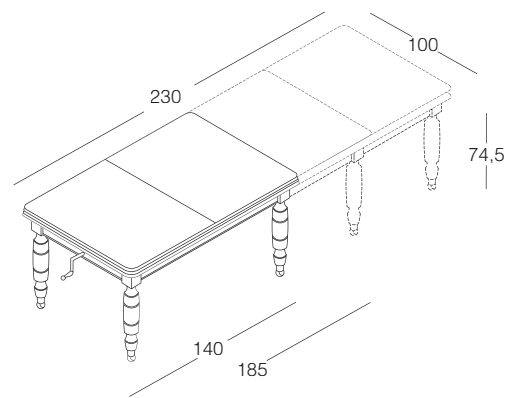

Tavolo in legno con piano allungabile in tre misure.  
Gambe in massello tornito e ruote metallo finitura canna  
di fucile.

Wooden table with extensible top in three sizes.  
Legs in solid turned wood, metal wheels varnished Canna  
di Fucile.





# Vassoia

DESIGN CRS HALIFAX - ALESSANDRO GEDDA

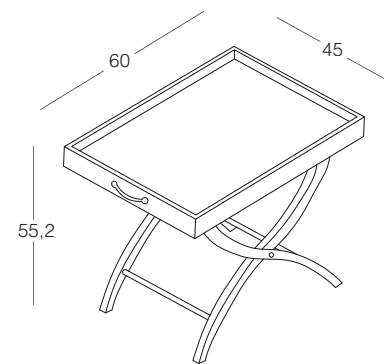

Tavolino multiuso con struttura in massello.  
Vassoio asportabile.

*Multi-purpose coffee table with structure in solid wood.  
Removable tray.*





# Espositore Console

DESIGN ANTONIO CITTERIO - ALESSANDRO GEDDA

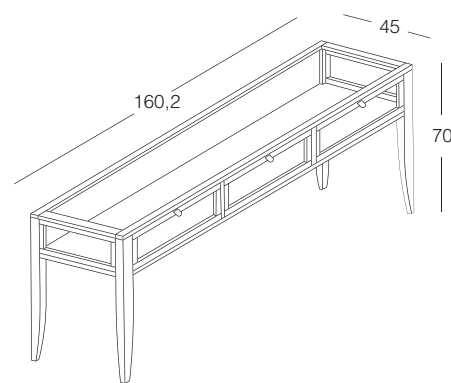

Console con struttura in massello e vetro temperato.  
Aperture frontali a ribalta.

Console with structure in solid wood and tempered glass.  
Front pull-down opening.





# Cassettaio

DESIGN MARIANNE DAY LEWIS - ALESSANDRO GEDDA

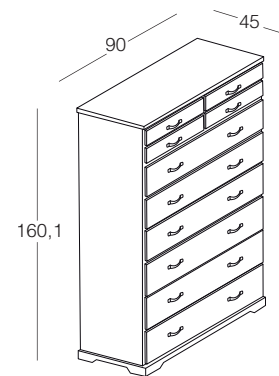

Cassetiera in legno con maniglie in metallo.

Wooden chest of drawers with metal handles.





# Bacheca

DESIGN ANTONIO CITTERIO - ALESSANDRO GEDDA

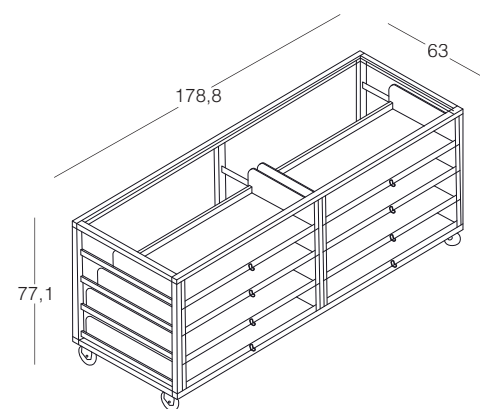

Contenitore vetrina dotato di ruote. Struttura in massello e vetro temperato. *Showcase on wheels. Structure in solid wood and tempered glass.*





# Vetriera

DESIGN MARIANNE DAY LEWIS - ALESSANDRO GEDDA

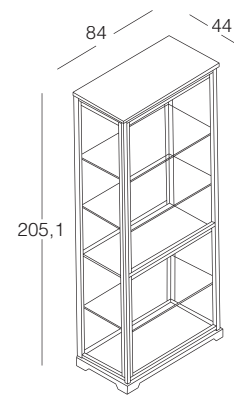

Contenitore vetrina con struttura in massello e vetro temperato. Aperture laterali.

*Vitrine with structure in solid wood and tempered glass. Side opening.*









**AMPIA E COMODA UNA POLTRONA DOVE  
APPISOLARSI CON DOLCEZZA, IN SOLITARIA  
O IN CONDIVISIONE QUANDO SI OFFRE  
NELLA SUA FORMA ESTESA , ADORNATA  
DI VESTI PREZIOSE.**

*AN AMPLE AND COMFORTABLE ARMCHAIR WHERE TO FALL  
ASLEEP SOFTLY, ALONE OR SHARING WITH OTHERS IN THE  
OPEN VERSION, ADORNED WITH PRECIOUS DRESSES.*

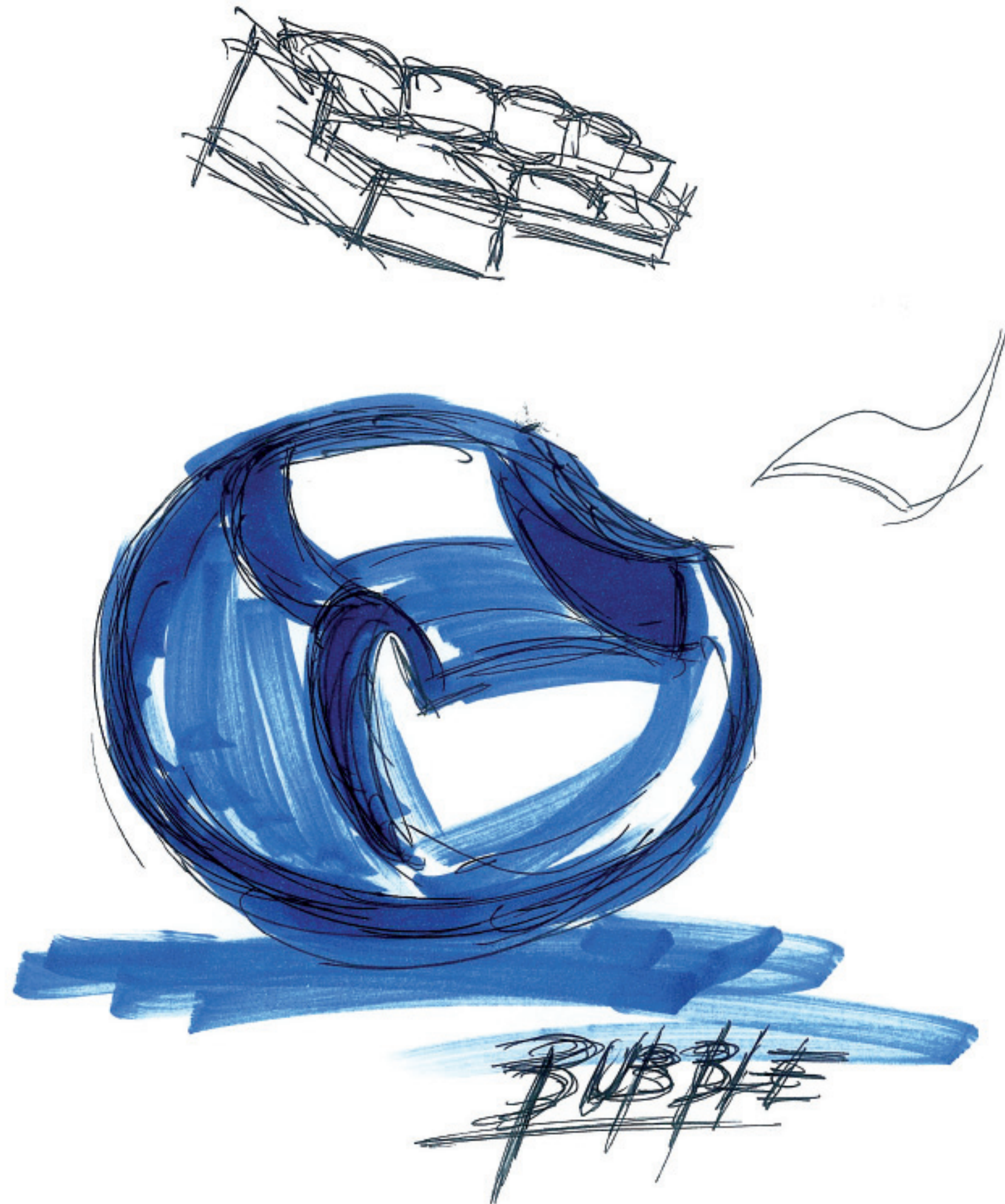

## CONTEMPORANEO

### **Poltrone e Divani** *Armchairs and Sofas*

Bubble e pouff	28
Double	30
Kompasso	32
Point	34
Ambrogio	36
Blade	40
Cover	44
Lama	46



# Bubble e pouff

DESIGN MARCO BOGA

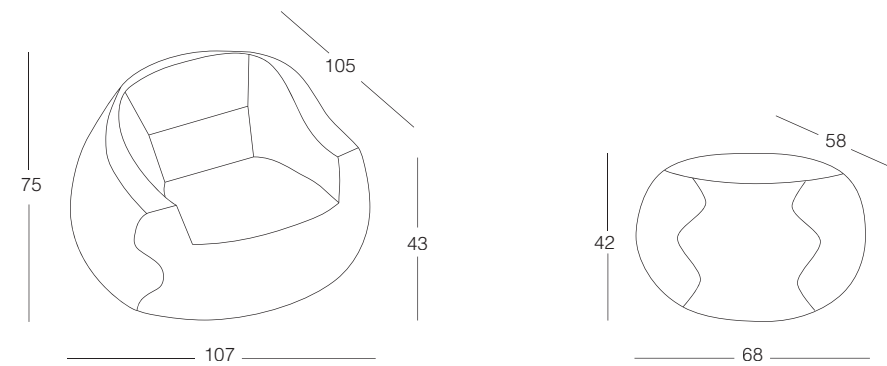

Poltrona con struttura in metallo annegato nel poliuretano con piastra girevole. Pouff in poliuretano espanso. Rivestimento in tessuto sfoderabile o in pelle fisso.

Armchair with metal structure embedded in polyurethane foam with swivel plate. Pouf in polyurethane foam. Removable fabric cover or non removable leather cover.



# Double

DESIGN FABRIZIO ZAPPA

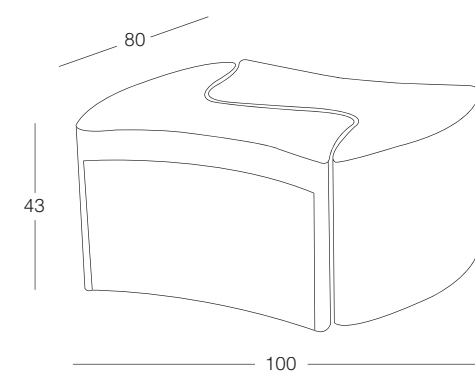

Pouff con fusto in legno e imbottiture in poliuretano espanso. Rivestimento in pelle fisso. Profili di appoggio in metallo tubolare finitura canna di fucile.

*Pouf with wooden frame and polyurethane foam upholstery. Non removable leather cover. Metal support profiles finish canna di fucile.*





# Kompasso

DESIGN CRS HALIFAX

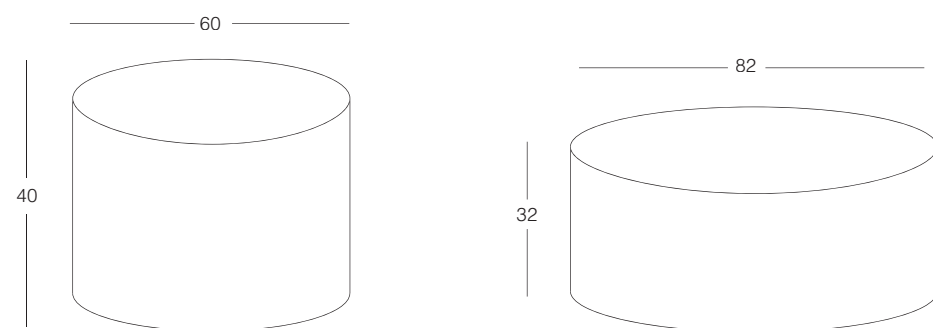

Pouff con fusto in legno e imbottitura in poliuretano a densità differenziata.  
Rivestimento in tessuto sfoderabile o in pelle fisso.

*Pouf with wooden frame and different density polyurethane foam upholstery.  
Removable fabric cover or non removable leather cover.*





# Point

DESIGN PIVA ASSOCIATI

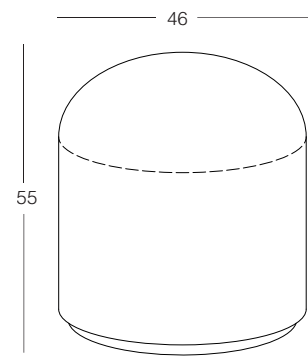
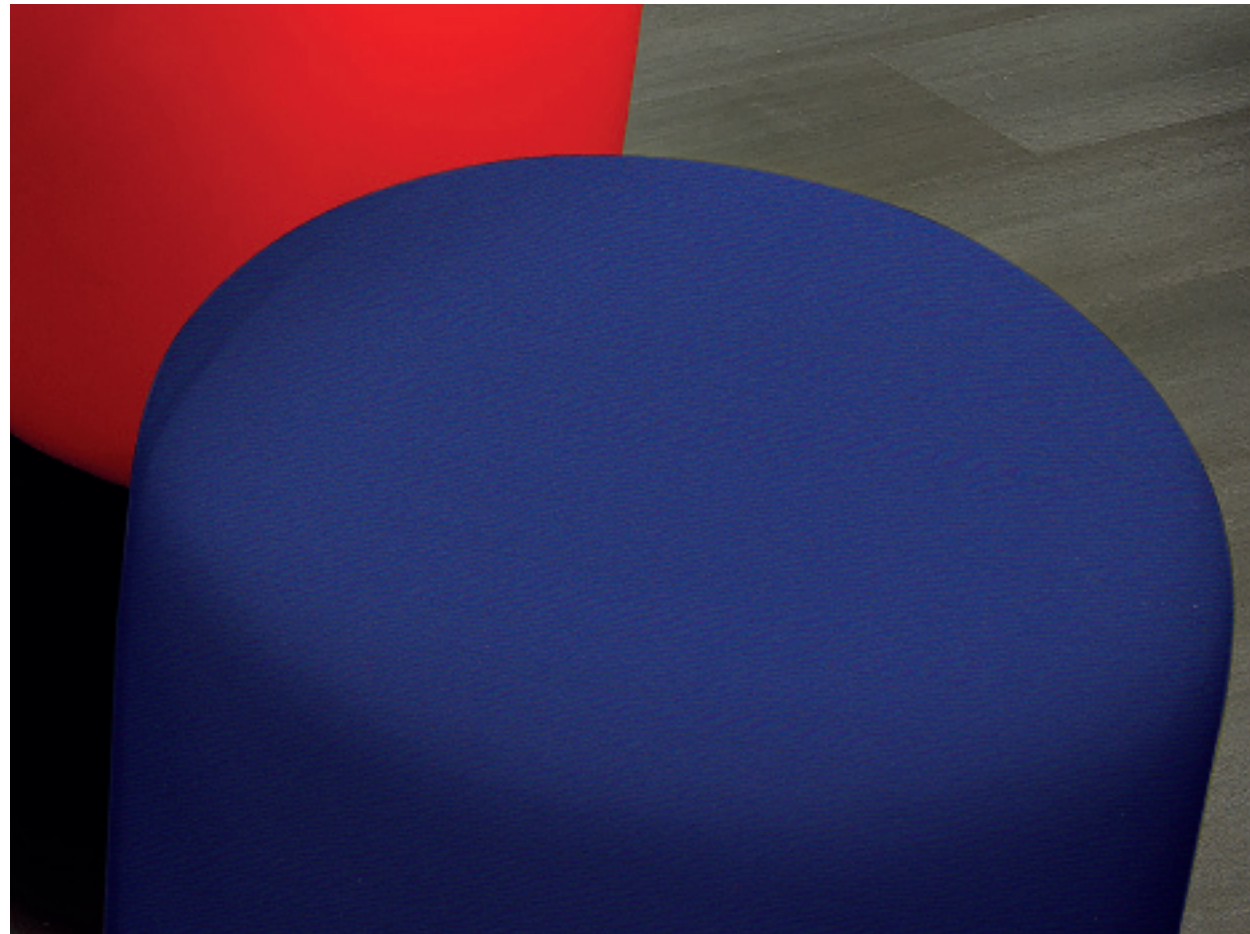

Pouff girevole con fusto in legno e imbottitura in poliuretano a densità differenziata.  
Rivestimento in tessuto bi-elastico sfoderabile.

*Swivel pouf with wooden frame and different density polyurethane foam upholstery.  
Removable stretch fabric cover.*





# Ambrogio

DESIGN CRS HALIFAX



Divano componibile con struttura in legno rivestita in poliuretano a densità differenziata. Cuscino schienale in piuma con inserto in poliuretano. Rivestimento in tessuto sfoderabile o in pelle fisso.

*Modular sofa with wooden frame covered with different density polyurethane foam. Backrest cushion in feather with polyurethane internal support. Removable fabric cover or non removable leather cover.*







ALZARE  
LENOTA

- per gli - camp di f  
 " bump  
 - Venne collezionato  
 con tessuti storici  
 CON CAVALLINO  
 A  
 V/XV

CANNA BI FUCUS  
SABINATA





# Blade

DESIGN DANIELE LO SCALZO MOSCHERI



Sistema di sedute con struttura in legno rivestito in poliuretano espanso a densità differenziata. Cuscini sedile e schienale in poliuretano espanso. Rivestimento in tessuto sfoderabile o in pelle fisso. Piedini e retroschienale in metallo finitura canna di fucile.

*Seating system with wooden frame covered with different density polyurethane foam. Seat and back cushions in polyurethane foam. Removable fabric cover or non removable leather cover. Metal feet and back bar finish canna di fucile.*







*Handwritten in blue ink:* HARRON

*Handwritten in black ink:* DADA  
DADA

*Handwritten in blue ink:* DADA

*Handwritten in black ink:* DADA

*Handwritten in black ink:* DADA

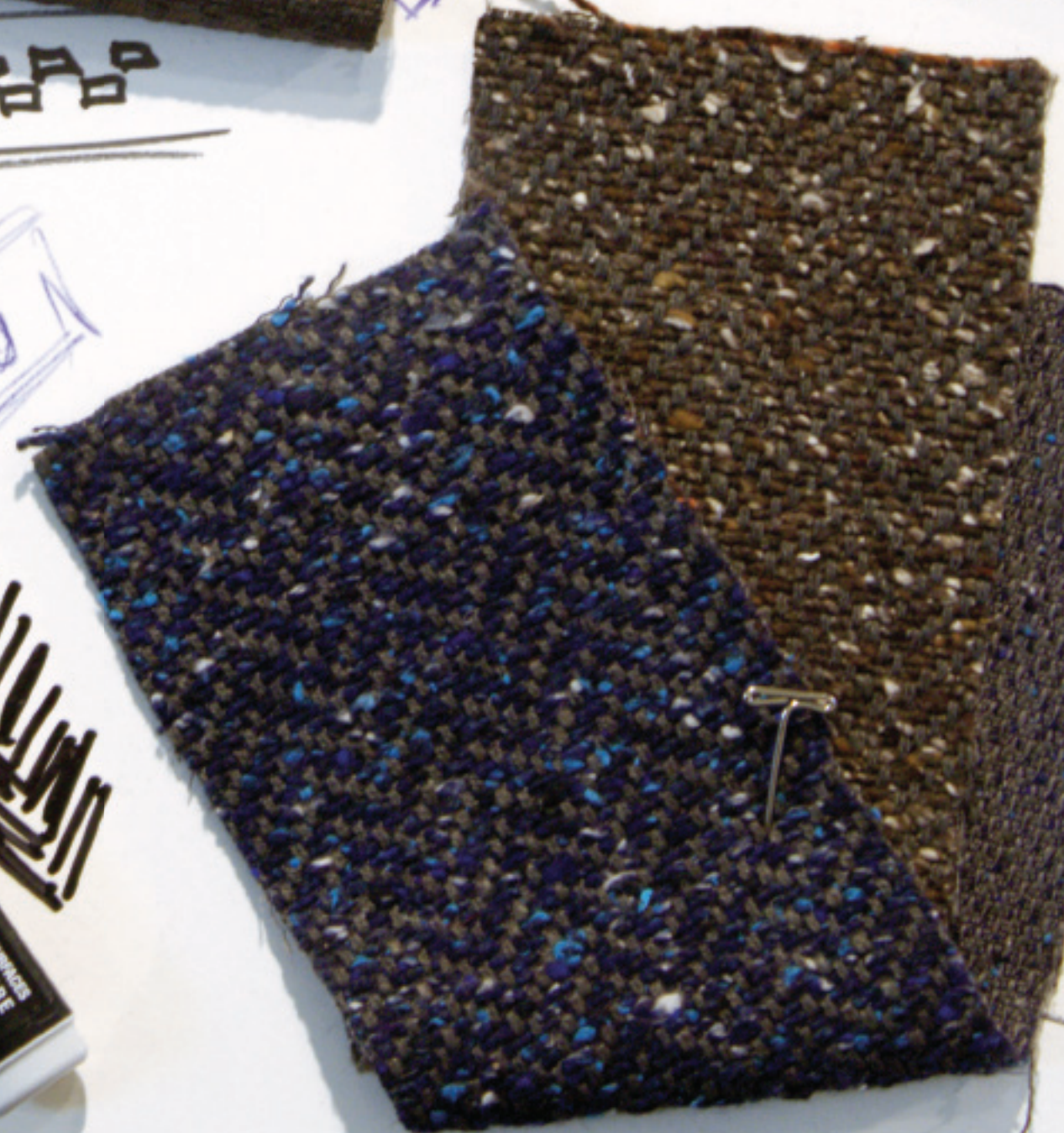



# Cover

DESIGN CRS HALIFAX



Sistema di sedute con struttura in legno rivestito in poliuretano espanso. Cuscini sedile e schienale nella versione misto piuma.

*Seating system with wooden frame covered with polyurethane foam. Seat and back cushions in mixed feathers.*





# Lama

DESIGN MAURO LIPPARINI



Sistema di sedute con base in acciaio. Schienale rialzato con supporti in acciaio e struttura in legno rivestita in poliuretano. Comprende un cuscino schienale in misto piuma ed un poggiatesta removibile in poliuretano. Rivestimento in tessuto sfoderabile o in pelle fisso.

*Seating system supported by a steel base frame. Raised back with steel supports and wooden frame covered with polyurethane. A mixed feather back cushion and a removable headrest in polyurethane are included. Removable fabric cover or non removable leather cover.*





Ambrogio

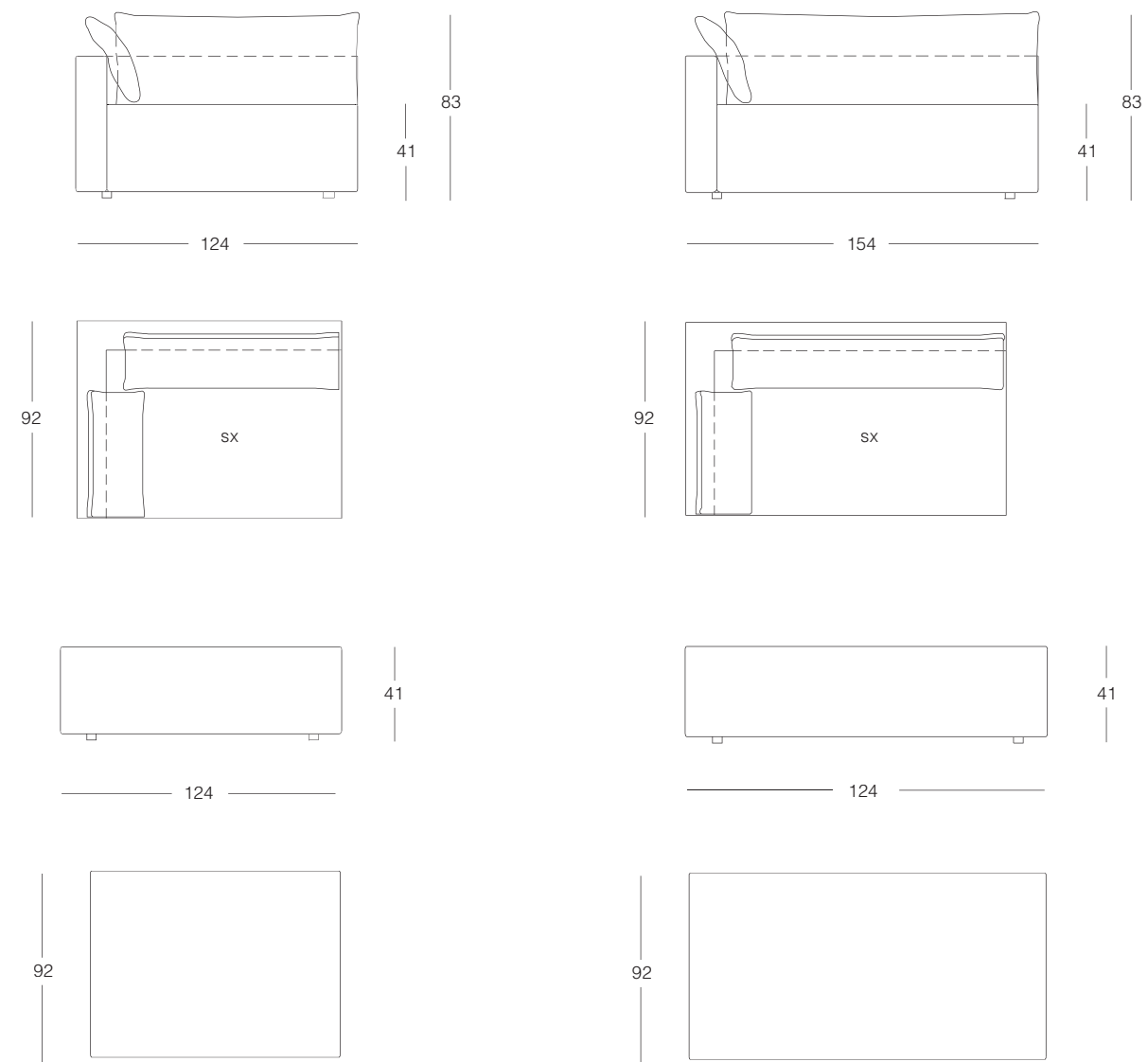

Blade

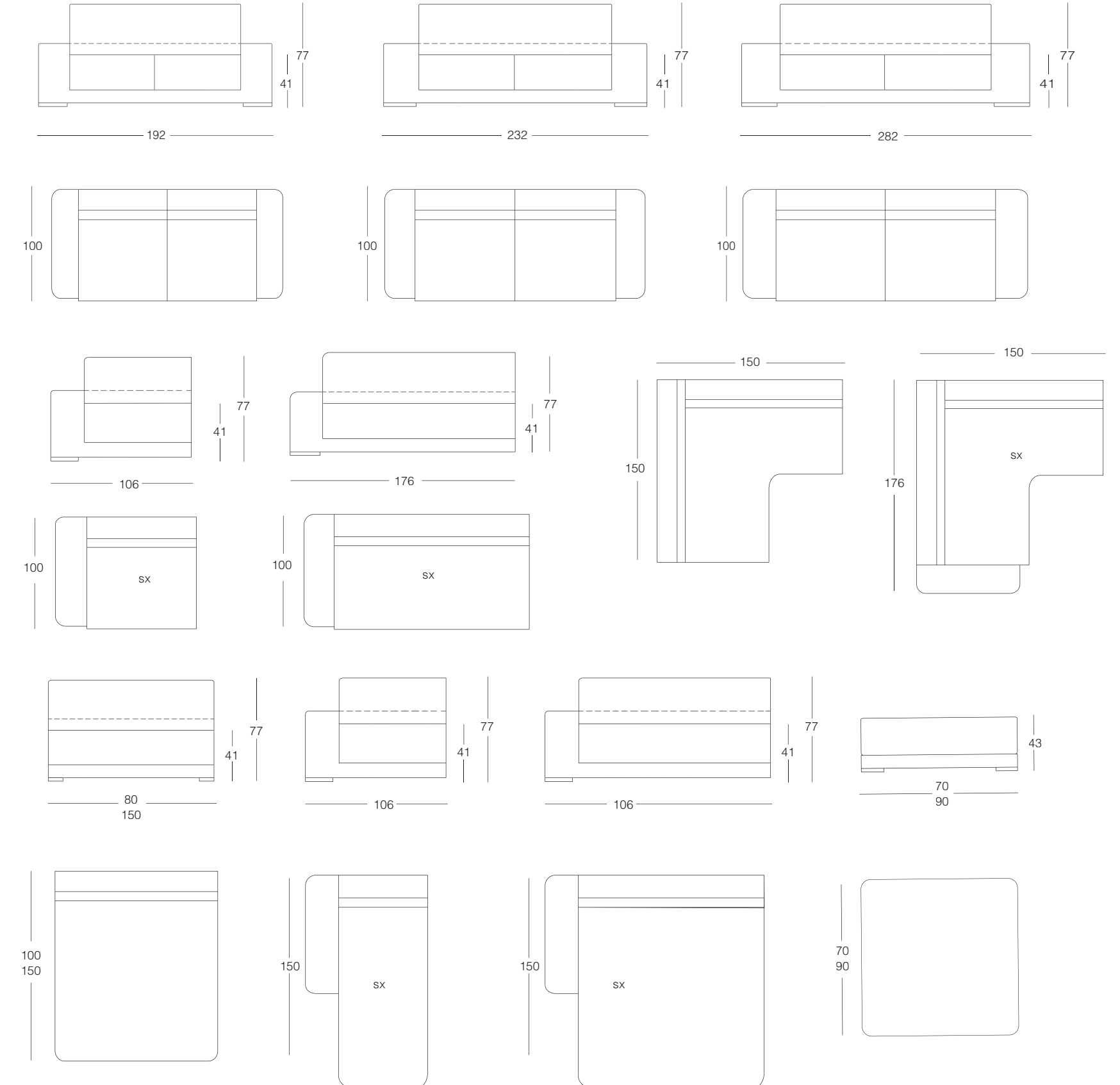



Cover

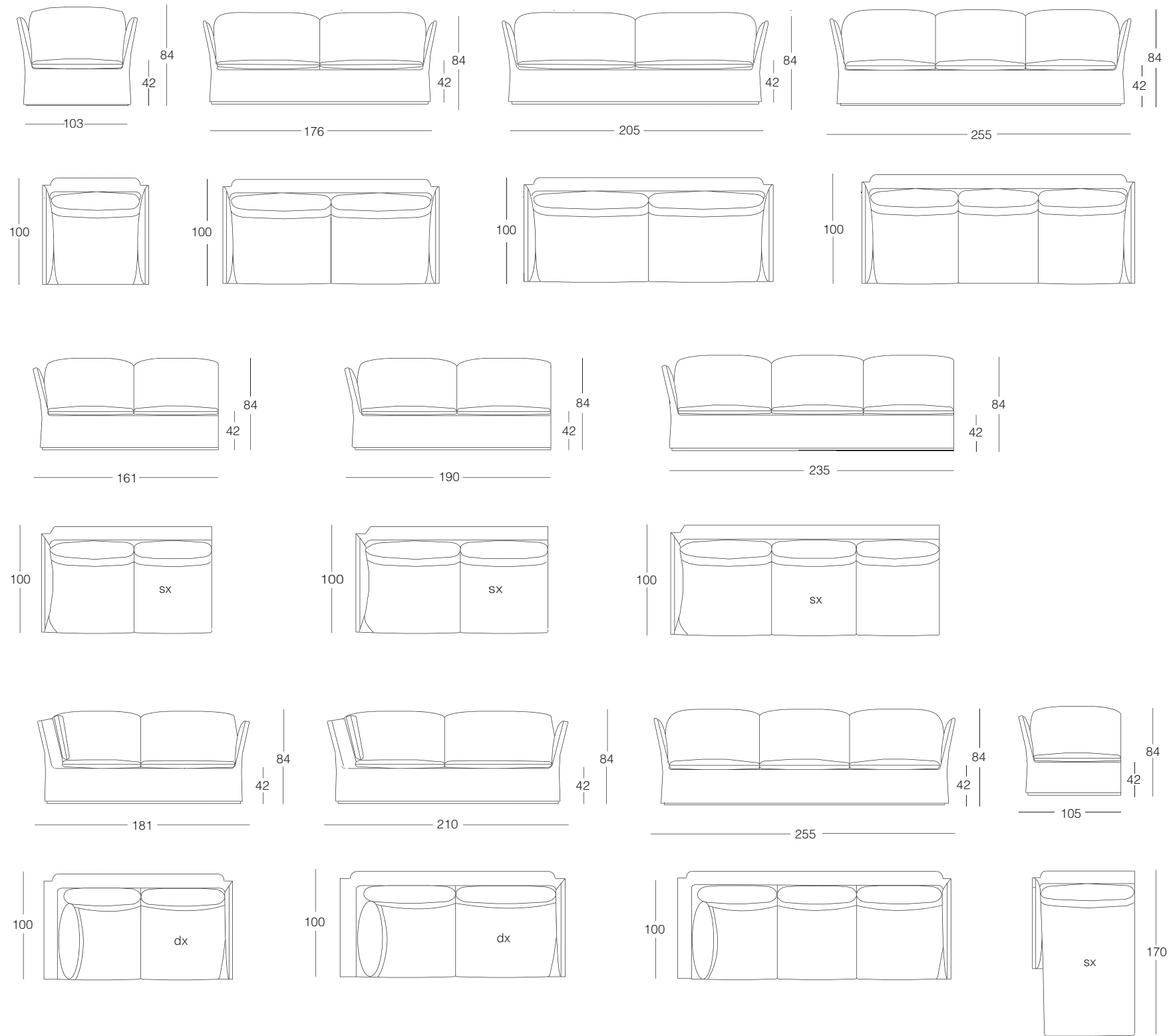

Lama

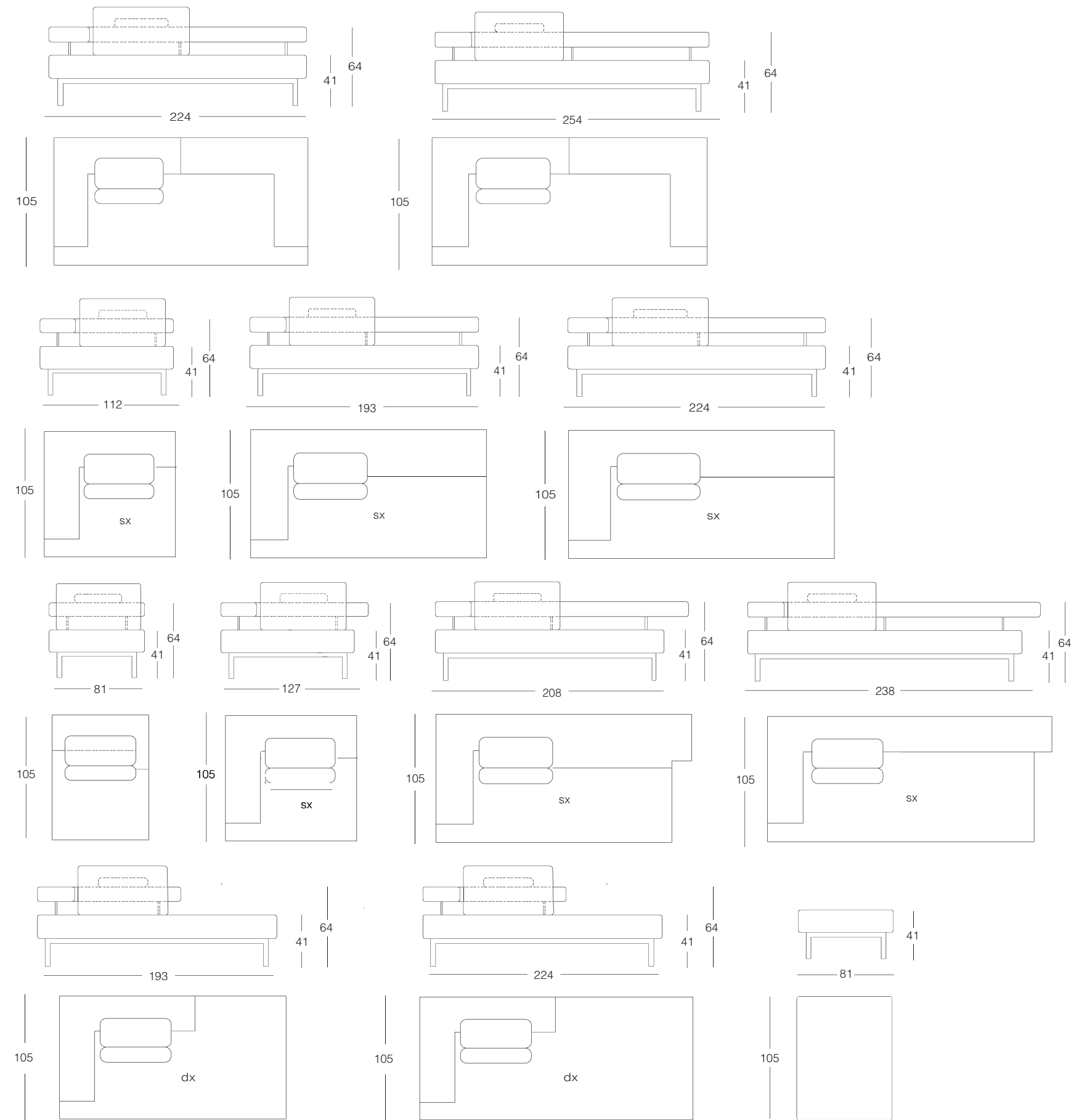





**LEGNO, LANE E TESSUTI, METALLI E CUOIO  
DANNO FORMA ALLE SEDUTE OGGETTI  
D'ARREDO CHE COMPLETANO CON TIPICITÀ  
LA ZONA GIORNO.**

*WOOD, WOOL AND FABRICS, METALS AND LEATHERS  
GIVE SHAPE TO THE SEATINGS, REAL FURNITURE OBJECTS  
COMPLETING THE LIVING AREA WITH TYPICALITY.*

## CONTEMPORANEO

---

### **Sedie** *Chairs*

Minni sedia	54
Minni sgabello	56
Teodolinda	58
Hosteria	62



# Minni sedia

DESIGN ANTONIO CITTERIO

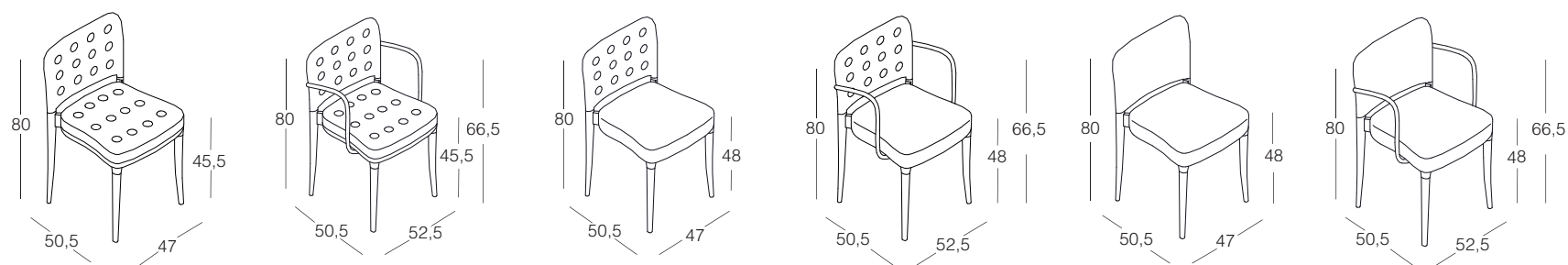

Sedia impilabile con gambe e braccioli in alluminio naturale. Sedile in materiale plastico o imbottito e rivestito con tessuto sfoderabile. Schienale in materiale plastico o foderato.

*Stackable chair with natural aluminium legs and armrests. Seat in plastic material or foamed and covered with removable fabric.*





# Minni sgabello

DESIGN ANTONIO CITTERIO

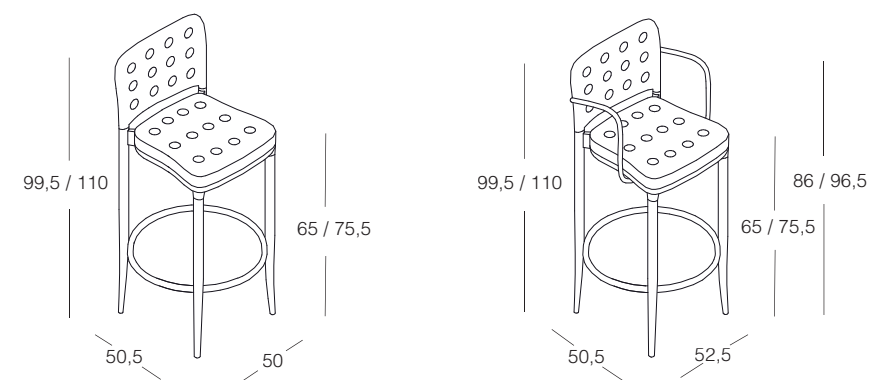

Sgabello con gambe e braccioli in alluminio naturale.  
Sedile e schienale in materiale plastico.

*Stool with natural aluminium legs and armrests.  
Seat and back in plastic material.*





# Teodolinda

DESIGN CRS HALIFAX

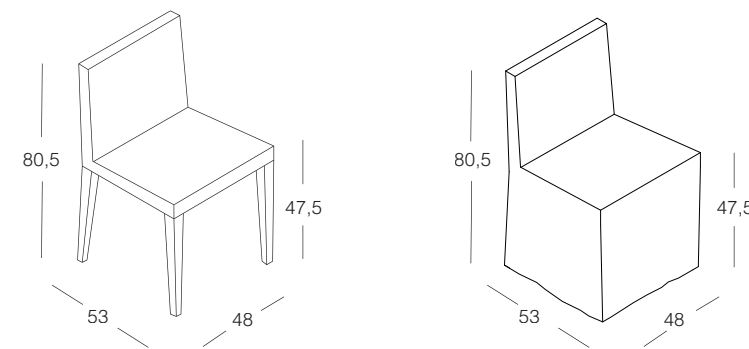

Sedia con struttura in profilato d'acciaio annegato nel poliuretano. Rivestimento in tessuto sfoderabile o in pelle fisso. Teodolinda con balza. Rivestimento in tessuto sfoderabile.

*Chair with steel structure embedded in polyurethane foam. Removable fabric cover or non removable leather cover. Teodolinda with flounce. Removable fabric cover.*









# Hosteria

DESIGN ALESSANDRO GEDDA

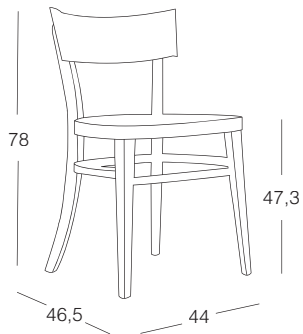

Sedia in legno laccato colore.

Wooden chair with colour lacquer finish.





# FUNZIONALE ED ESSENZIALE, SPOGLIO O IMBANDITO SPAZIOSO O RIDOTTO, SIMBOLO DI CONDIVISIONE E CONVIVIALITA'.

*FUNCTIONAL AND ESSENTIAL, PLAIN OR DRESSED,  
AMPLE OR SMALL, A SYMBOL OF SHARING AND CONVIVIALITY.*

## CONTEMPORANEO

---

### **Tavoli e Tavolini**

*Tables and Coffee Tables*

Ulisse	66
Vittorio fisso	68
Vittorio 300	70
Nodo	72
Hosteria	74
Carpenter	76
Mirto	78
Vittorio tavolino	80
Quadro	82
Naos	84
Art - Art Light	86
Swing	88



# Ulisse

DESIGN CRS HALIFAX

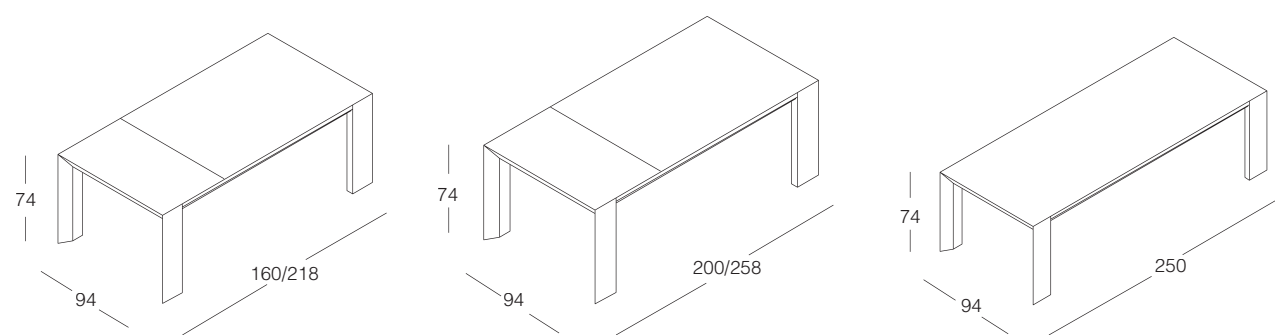

Tavolo rettangolare allungabile o fisso con piano e gambe in legno. *Rectangular extensible or fixed table with wooden top and wooden legs.*





# Vittorio fisso

DESIGN LA MENSA

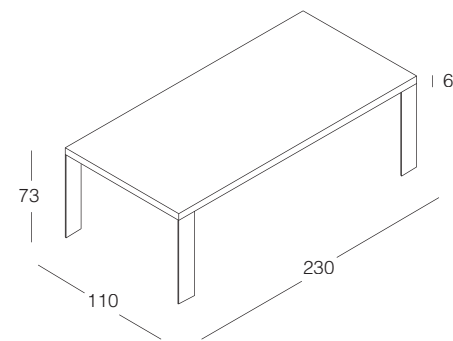
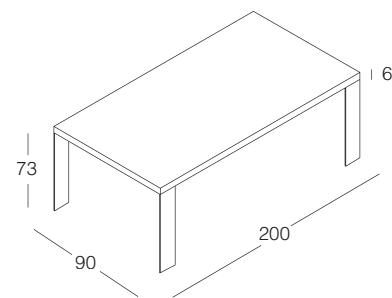

Tavolo rettangolare con piano in legno di forte spessore e gambe in metallo finitura canna di fucile.

*Rectangular table with a thick wooden top and metal legs finish canna di fucile.*





# Vittorio 300

DESIGN LA MENSA

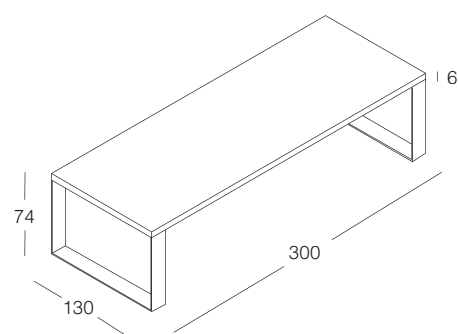

Tavolo rettangolare con piano in legno di forte spessore e gambe in metallo finitura canna di fucile.

*Rectangular table with a thick wooden top and metal legs finish canna di fucile.*





# Nodo

DESIGN CARLO BARTOLI

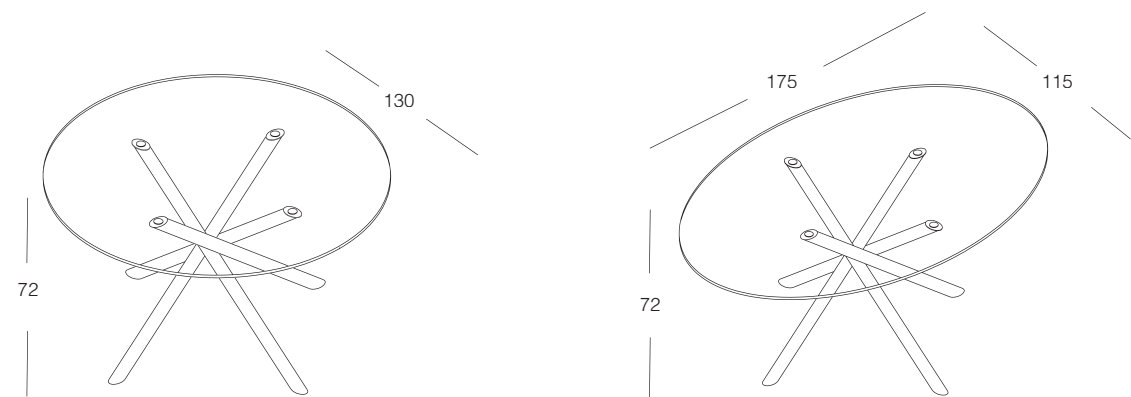

Tavolo ovale o rotondo con piano in cristallo e gambe in acciaio cromato lucido o finitura canna di fucile.

Oval or round table with top in glass and legs in stainless steel finish glossy chromed or canna di fucile.





# Hosteria

DESIGN ALESSANDRO GEDDA

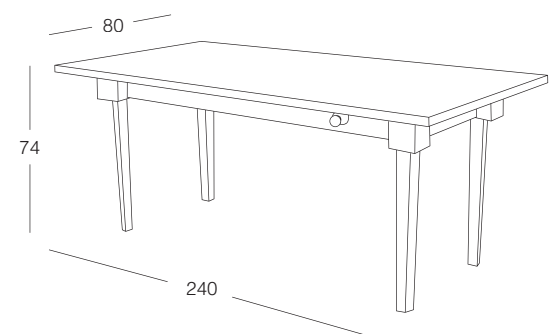

Tavolo con struttura in legno laccato colore. Piano in marmo o legno laccato colore.

*Table with structure in colour lacquered wood. Top in marble or colour lacquered wood.*





# Carpenter

DESIGN CRS HALIFAX

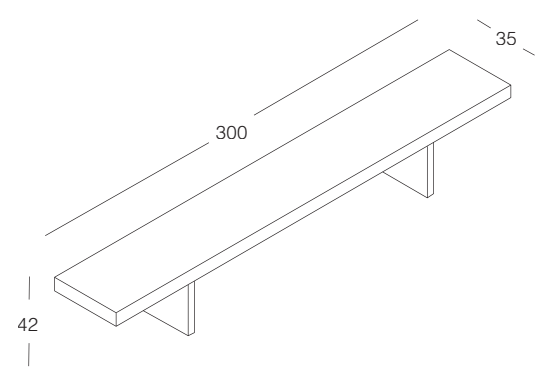
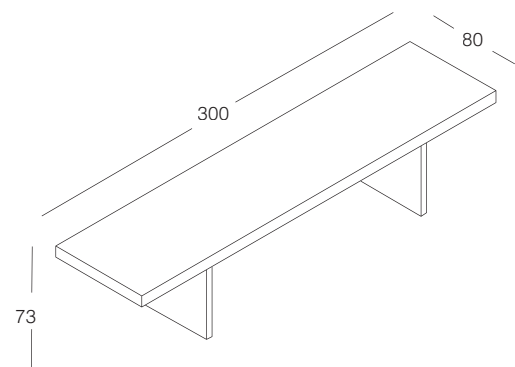

Tavolo e panca in massello di teak naturale, finitura grezza.

*Table and bench in solid teak wood, raw finish.*





# Mirto

DESIGN MIRTO ZOCCA

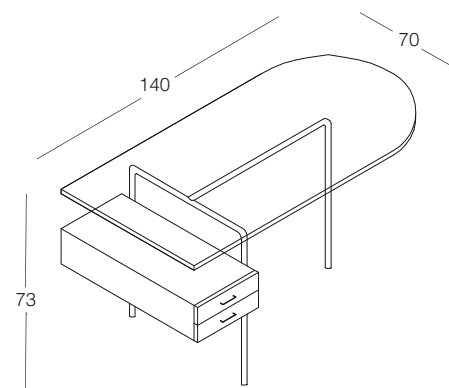

Scrivania con piano in vetro trasparente temperato, struttura in metallo cromato o finitura canna di fucile e cassettera in legno.

*Desk with top in transparent tempered glass, metal structure finish chromed or canna di fucile and wooden drawer unit.*





# Vittorio tavolino

DESIGN LA MENSA

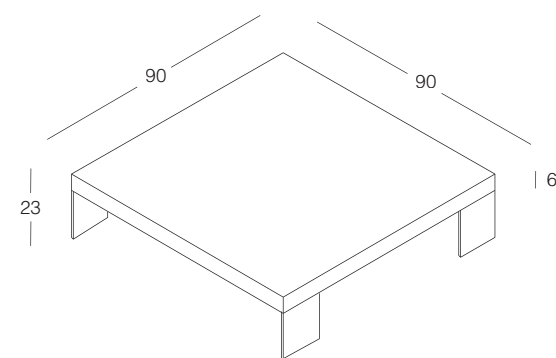

Tavolo basso con piano in legno e gambe in metallo  
finitura canna di fucile.

*Coffee table with wooden top and metal feet finish canna  
di fucile.*

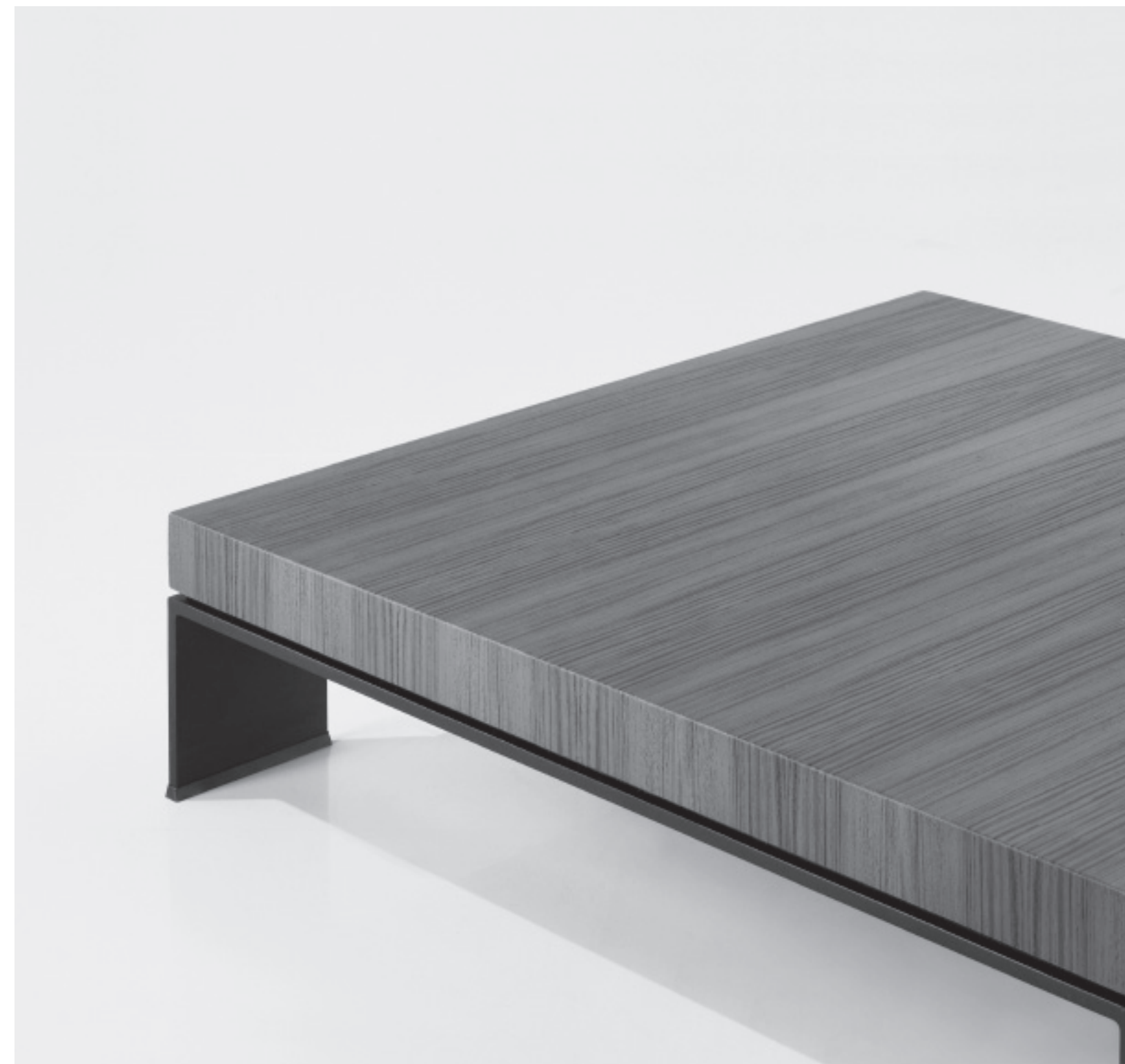



# Quadro

DESIGN CRS HALIFAX

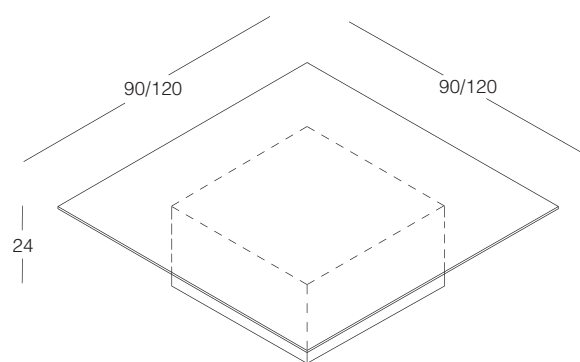

Tavolo basso completamente in metallo finitura canna di fucile. *Coffee table entirely in metal finish canna di fucile.*





# Naos

DESIGN CRS HALIFAX

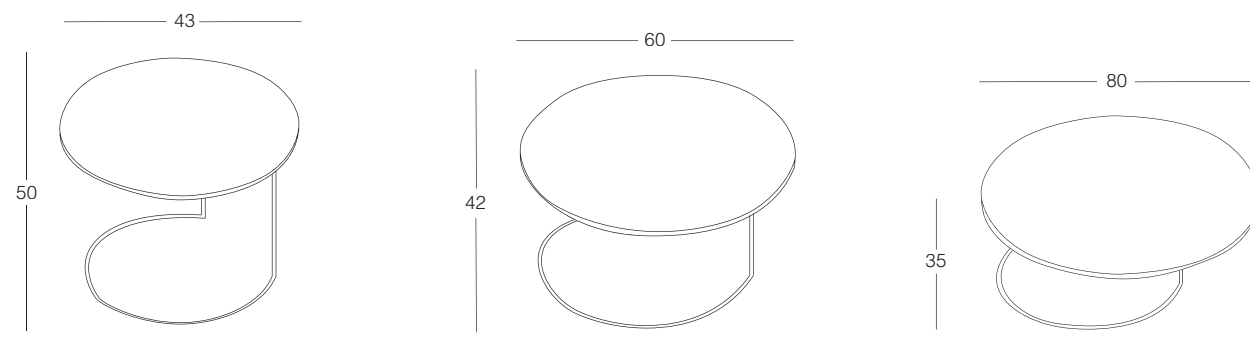

Serie di tavolini con struttura in metallo finitura canna di fucile e piano d'appoggio laccato.

*Range of coffee tables with metal structure finish canna di fucile and lacquered top.*





# Art - Art Light

DESIGN CRS HALIFAX

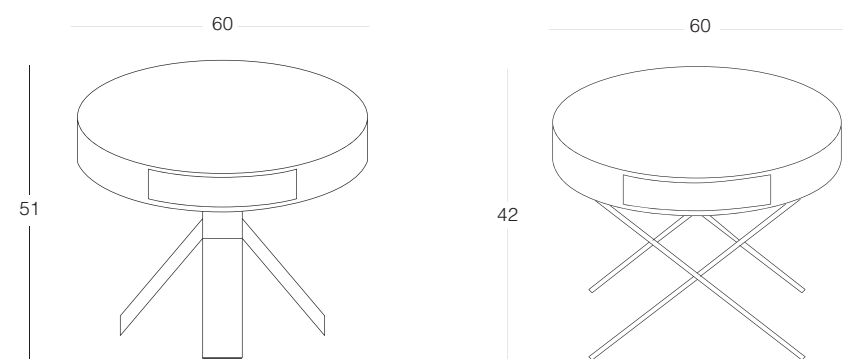

Tavolini con basi in metallo finitura canna di fucile e piano con cassetto in legno laccato.

*Coffee tables with metal bases finish canna di fucile and top with drawer in lacquered wood.*

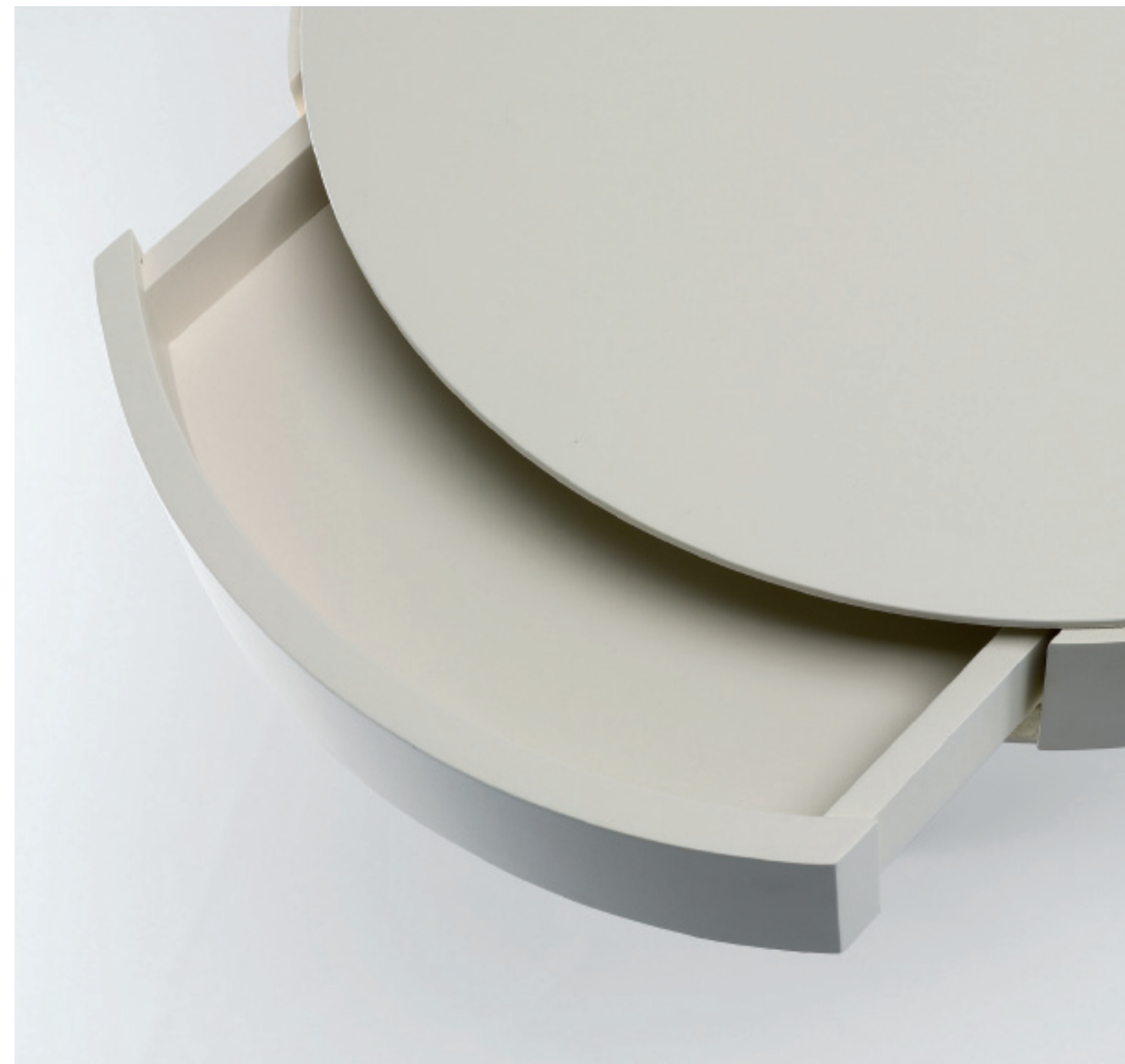



# Swing

DESIGN CRS HALIFAX

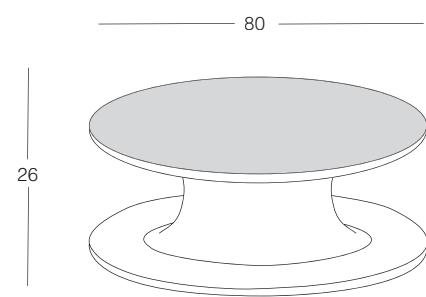

Tavolini con struttura in poliuretano espanso laccato e top in vetro verniciato.

*Coffee table with structure in lacquered polyurethane foam and top in lacquered glass.*

