

Zephyr

Carlo Colombo

Artemide[®]



Zephyr

Author

Carlo Colombo

Carlo Colombo graduated in architecture from the Politecnico di Milano in 1993 and began to work, dedicating himself, above all, to design and marketing of industrial products, graphics, and set-ups, collaborating with the best brands of Italian design. Since 2011 he has been teaching design at the University of Beijing. In 2013 he founded A++ architecture studio with Paolo Colombo in Lugano, which deals with interiors and large-scale projects all over the world, with studios in Lugano, Zurich, New York, Miami, and Dubai. His projects have been exhibited in Paris, at the Weserburg Museum of Modern Art in Bremen (1995), at the Museum of Decorative Arts in Cologne (1996), at the Milan Triennale (2016), and at MARCA, Museum of the Arts of Catanzaro (2017).



Zephyr

Carlo Colombo
2023

Zephyr is a minimalist, elegant chandelier with a modular frame that enables infinite custom layouts to be designed to fit the needs of each project.

The modular element is a double cylindrical diffuser with a central body that encloses the light sources and, by means of two rings rotating on the same axis, defines the position of the neighbouring lighting bodies by positioning the connecting structural elements.

The diffuser is transparent glass hand-blown and ground to create a horizontal texture that alternates transparent and opaline diffusing stripes.

This workmanship elegantly enriches the diffuser but above all creates a glare-free diffusion of light along the cylindrical body.

It is a contemporary interpretation of the traditional chandelier: the craftsmanship of the glass is combined with simple shapes and optical flair to reinterpret glass processing technologies, not just through decorative pieces, but also as functional tools for controlling and distributing light. Perfect for both private and public spaces, it combines formal elegance with an intelligent performance in terms of reduced consumption.

Available in a circular and linear version, thanks also to the electronic intelligence, it allows maximum compositional freedom to create customised solutions with shapes and sizes that can be freely adapted to illuminate and personalise any space.

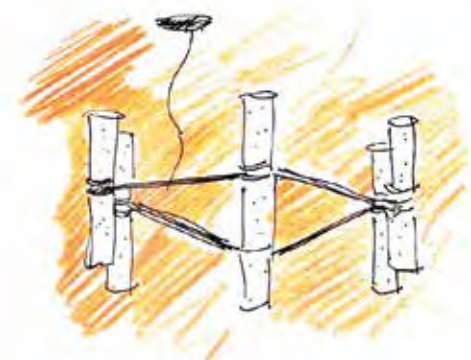
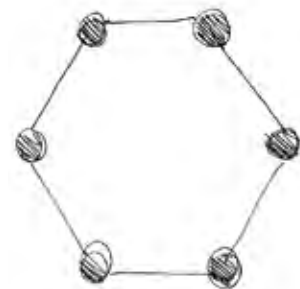

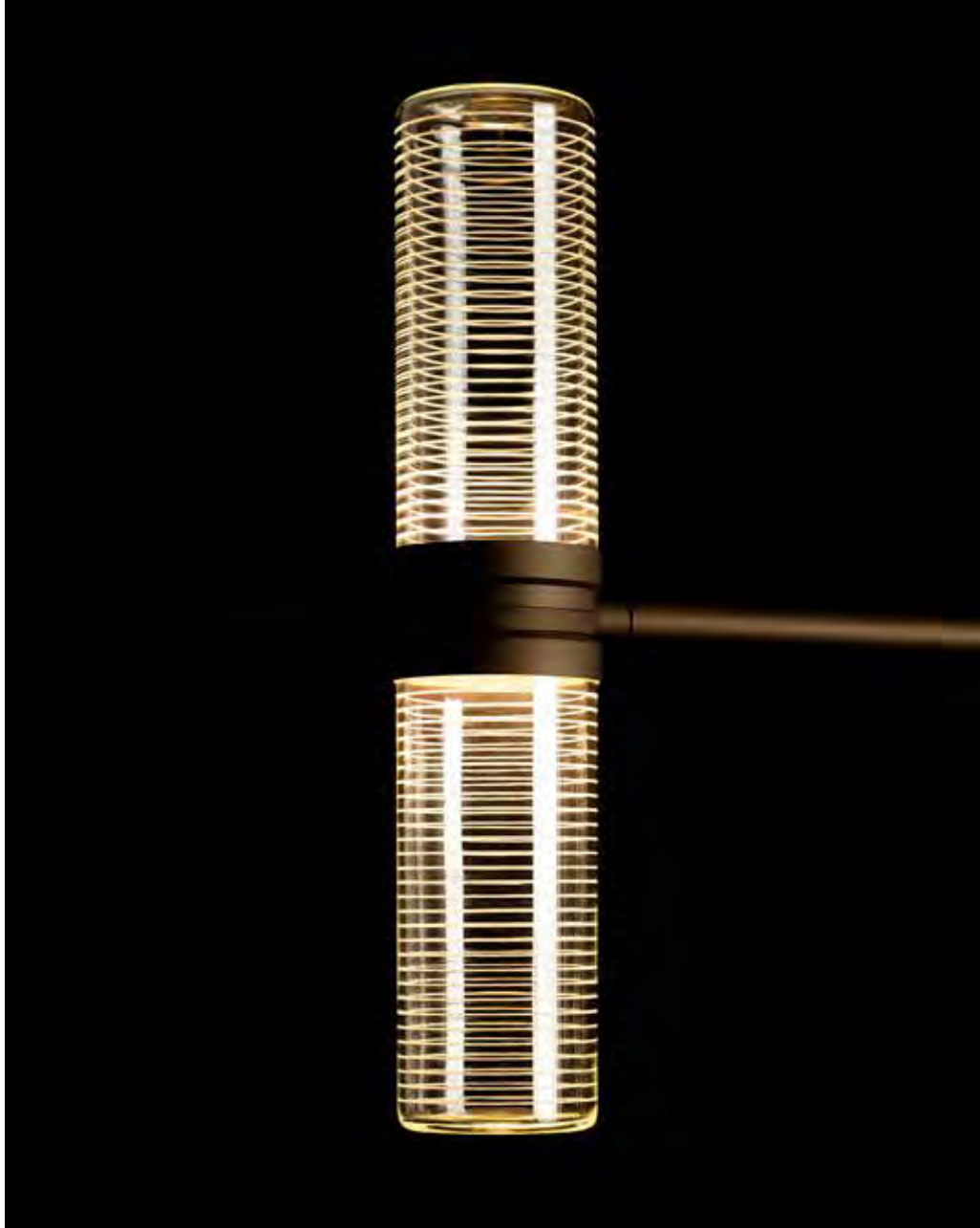

Handwritten signature
Arto - the
2022



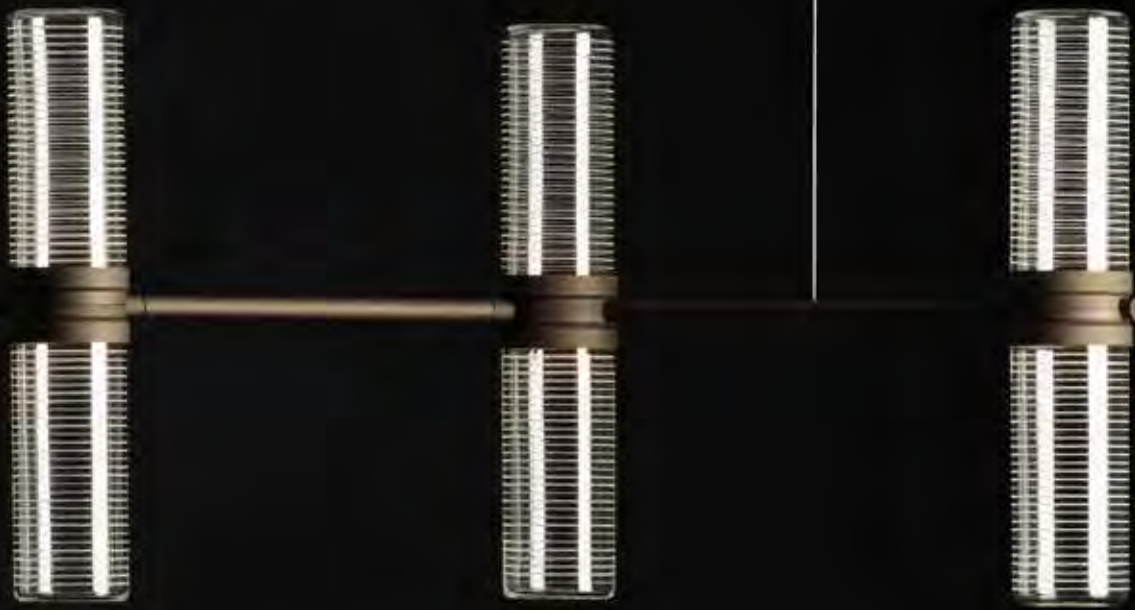

“Thin glass cylinders create a suggestive lighting harmonies. The horizontal engraving of the glass cleverly conceals the light source. Zephyr is a suspended sculpture, a warm and elegant light, a versatile collection of design and art.”

Carlo Colombo

Zephyr Linear











Zephyr Ring



Zephyr Chandelier

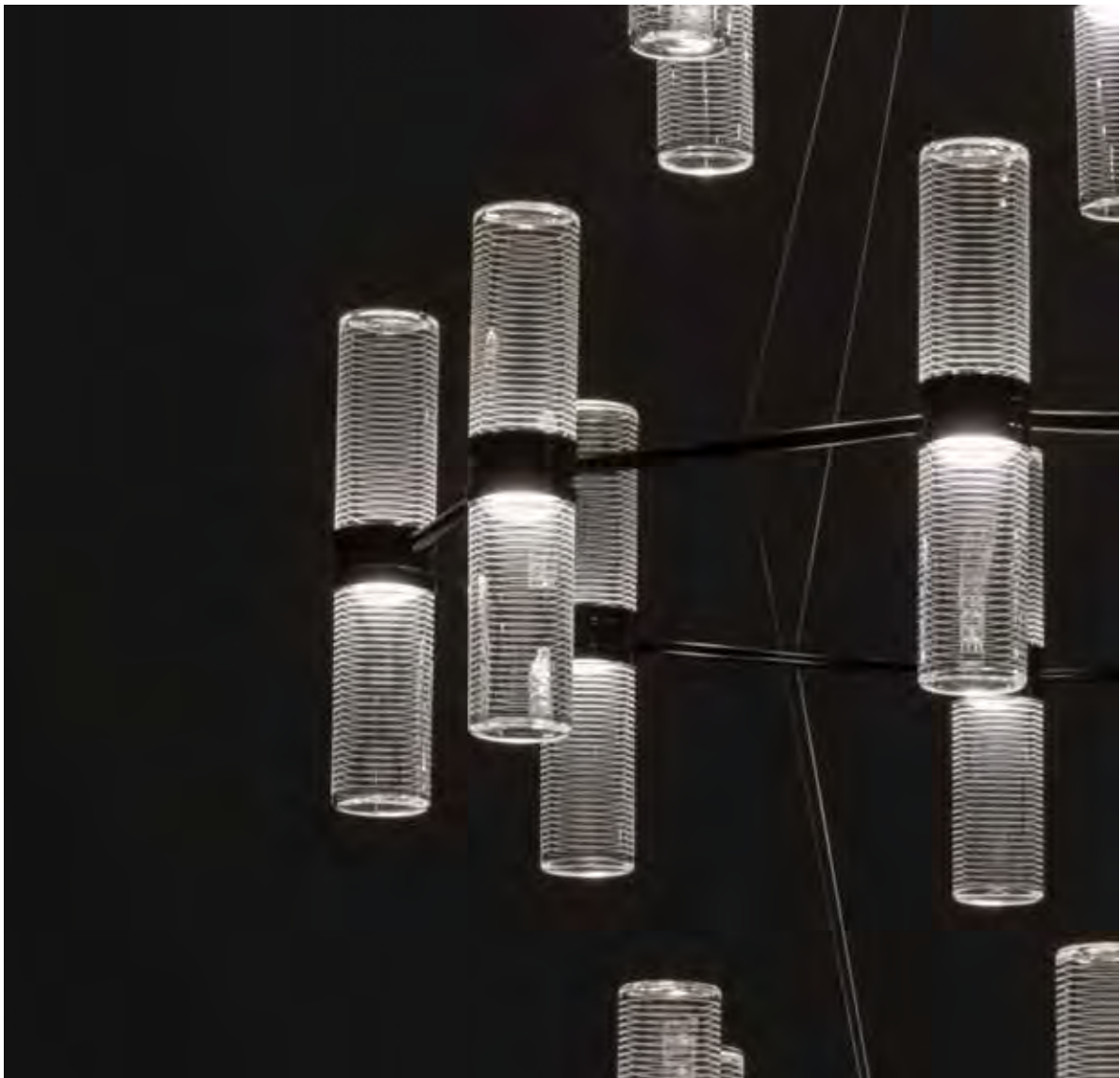



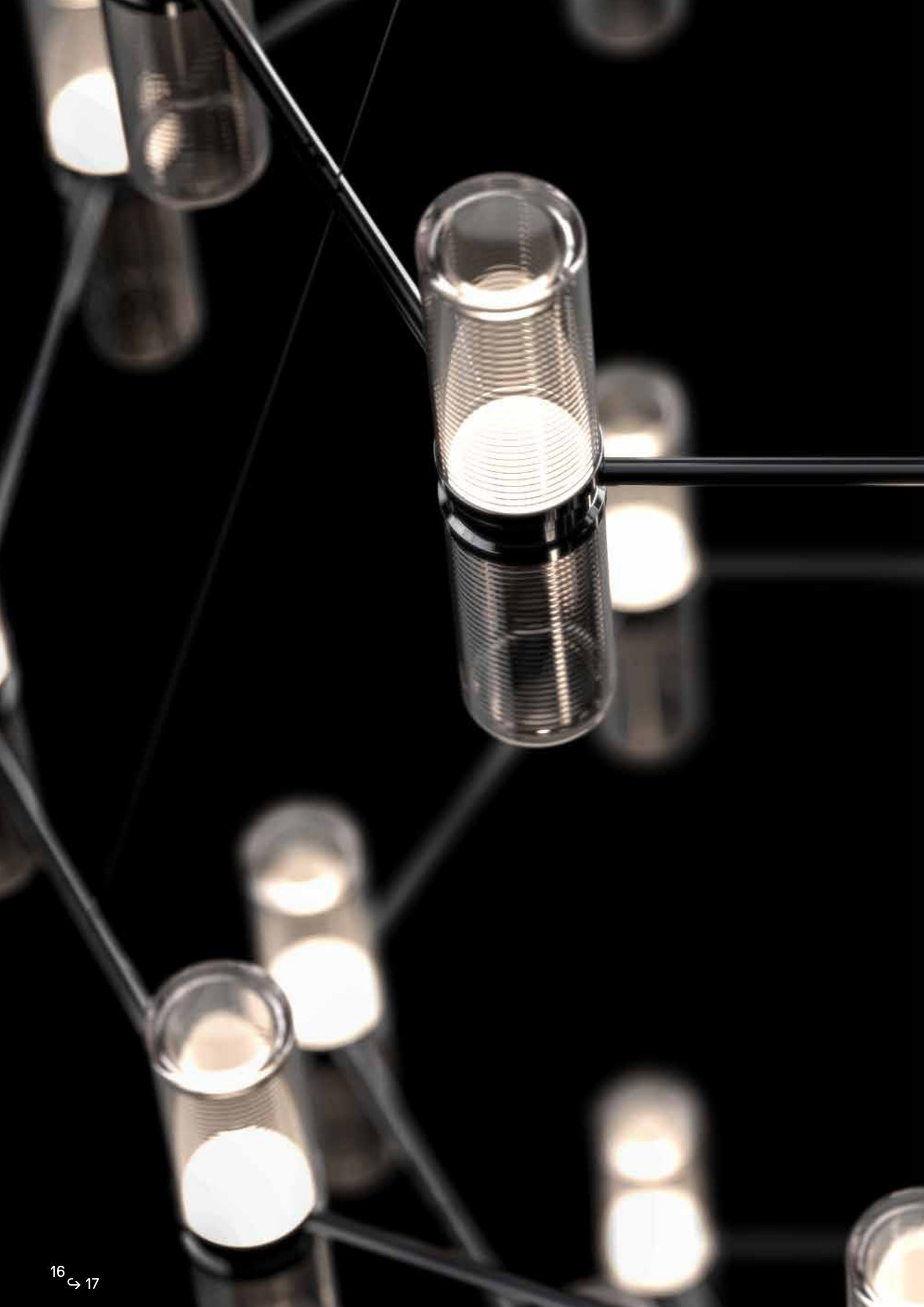

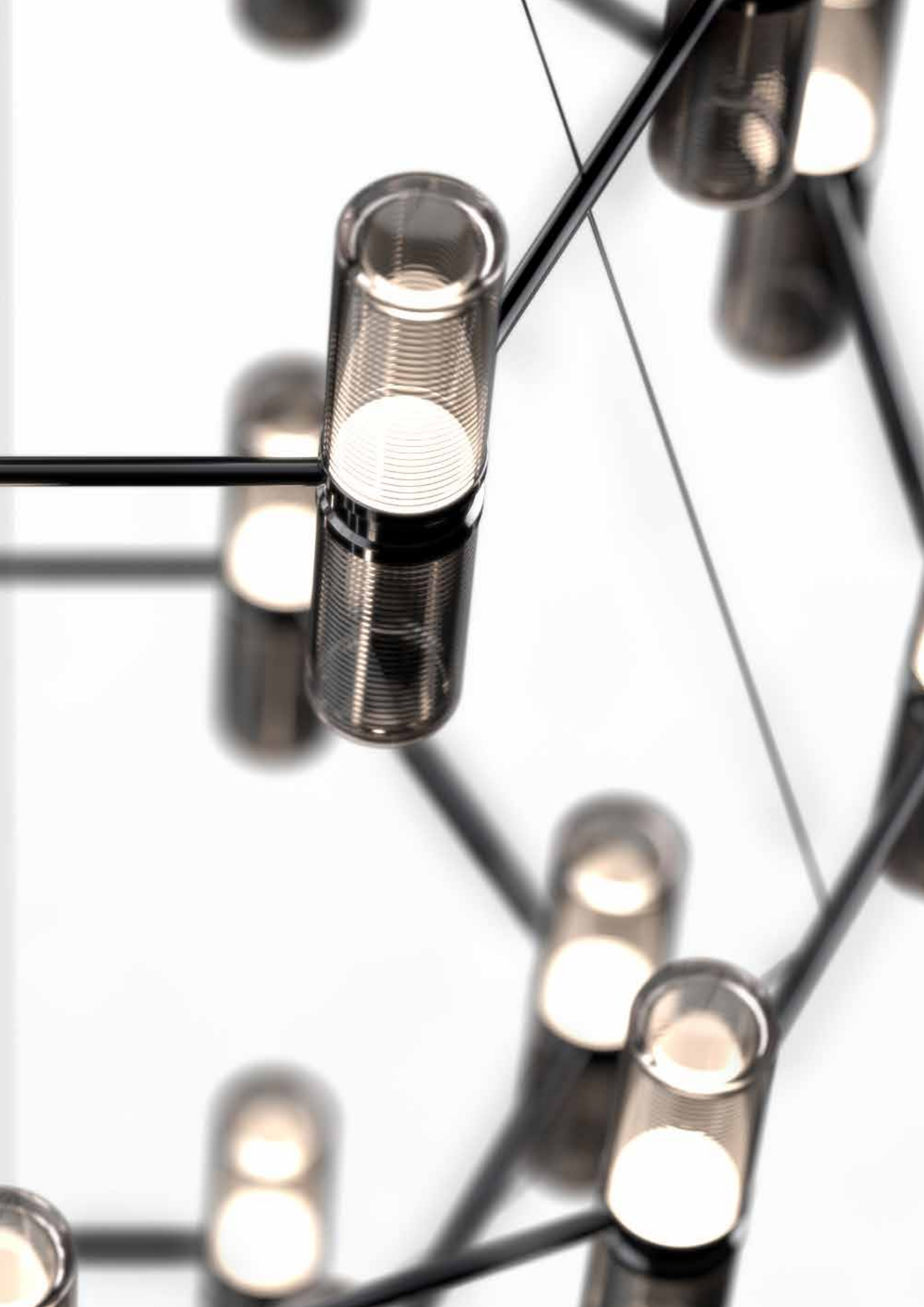

Zephyr Table









Zephyr Family

Materials: Glass and alluminum.

Colours:

- Black
 - Bronze
 - Gray
- CCT: 3000K
CRI=90

Zephyr Linear:

Total Power: 80W
Delivered Luminous Flux: 4950 lm

Zephyr Ring:

Total Power: 80W
Delivered Luminous Flux: 4950 lm

Zephyr Chandelier:

Total Power: 310W
Delivered Luminous Flux: 19800 lm

Zephyr Table:

Total Power: 13W
Delivered Luminous Flux: 400 lm

Zephyr Linear

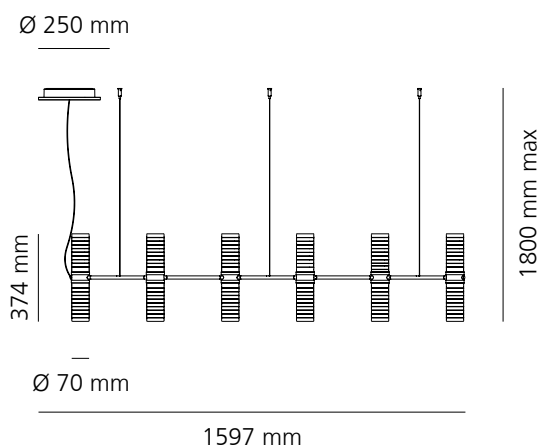

Zephyr Chandelier

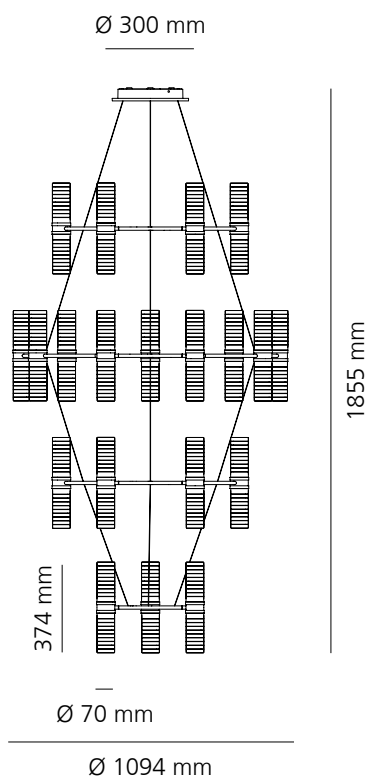

Zephyr Ring

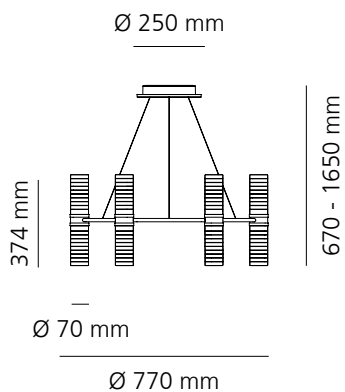

Zephyr Table

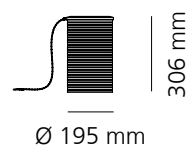

ZEPHYR LINEAR

Colour	Code	App Code
●	1782030A	1782030APP
●	1782040A	1782040APP

ZEPHYR RING

Colour	Code	Code
●	1781030A	1781030APP
●	1781040A	1781040APP

ZEPHYR CHANDELIER

Colour	Code	
●	1783030A	
●	1783040A	

Colour	Dali Code	App Code
●	1784030A	1784030APP

ZEPHYR TABLE

Colour	Code
●	1780030A
●	1780010A

Headquarters

Artemide S.p.A.

Via Bergamo, 18
20006 Pregnana Milanese (MI), Italy
Tel. +39 02 93518.1
Tel. +39 02 93526.1
Numero verde 800 834 093
(from Italy only)
info@artemide.com
artemide.com

Artemide S.p.A.

si riserva la facoltà di modificare, in qualunque momento e senza preavviso, le caratteristiche tecniche degli elementi illustrati nel presente catalogo.

Artemide S.p.A.

reserves the right to change, at any time and without prior warning, the technical specifications of any product illustrated in this catalogue.

Artemide S.p.A.

se réserve le droit de modifier, à n'importe quel moment et sans préavis, les caractéristiques techniques des éléments illustrés dans ce catalogue.

Artemide S.p.A.

behält sich das Recht vor jederzeit und ohne Ankündigung die technischen Daten der im Katalog abgebildeten Produkte zu ändern.

Artemide S.p.A.

se reserva la facultad de modificar, en cualquier y sin aviso previo, las características técnicas de los elementos ilustrados en el presente catálogo.