

Astep is the sole  
worldwide distributor  
of the Flos with  
Sarfatti collection

# **Timeless Masterpieces**

# FLOS with Sarfatti

**Astep is the sole worldwide distributor  
of the Flos with Sarfatti collection**

**Model 237**  
**Model 238**  
**Model 2109**  
**Model 2042**  
**Model 2065**  
**Model 2129**  
**Model 1063**  
**Model 1095**  
**Model 537**  
**Model 548**  
**Model 607**

WITH

## Timeless Masterpieces

The Flos with Sarfatti collection is a tribute to Gino Sarfatti who designed over 600 lamps between 1939 and 1973 and is renowned for his contribution to the modern architectural movement in lighting. Many of these designs appear exceptionally contemporary in terms of form, aesthetics and the relationship they establish with the people in the room.

In 2013, Flos re-issued five carefully selected Gino Sarfatti luminaires with cutting-edge LED technology, bringing them into the present day without detracting anything from the original sophisticated designs. In an extraordinary collaboration between the family behind Flos and Alessandro Sarfatti, the grandson of Gino Sarfatti, yet another luminaire has now been added, the iconic Model 2065.

Under the name 'Flos with Sarfatti', the two families will continue to explore and reintroduce the work of lighting master Gino Sarfatti. The selected models display the visionary and multi-faceted talent of Gino Sarfatti, his dedication to innovation and his commitment to creating humble, yet powerful pieces with the newest inventions at his hand. The diverse range of luminaires are held together by a coherent quality of timeless refinement. Masterpieces that awaken the power of light, technology and design.

The collection features six models: 548, 607, 1063, 1095, 2065 and 2129. With respect for the origin of the design, Astep's and Flos's roots and the proud artisanal and industrial traditions, the Flos with Sarfatti collection is made in Italy.



## Le Sfere di Gino Sarfatti

Throughout his life, the sky served as a muse for the renowned Italian lighting master Gino Sarfatti. He was fascinated by the perfect light emitted by the Moon, and one of Gino Sarfatti's most brilliant designs is inspired by the natural poetry of the luminous satellite.

The Le Sfere collection has not been in production since the 1970s, and it is with immense joy that Astep can now reintroduce this remarkable luminaire system with the single spheres and iconic chandeliers designed by Gino Sarfatti.

In 1959, Le Sfere was launched in a solar system of its own, revolving around a single luminous sphere. Le Sfere features a simple, yet elegant principle in which a blown opaline glass sphere is held in place by a painted aluminium ring. A refined embrace that lends the luminaire a graphic expression and brings forth its distinctive aesthetic.

The Le Sfere collection is the largest product family by Gino Sarfatti with models that have developed over time, from the first single sphere, Model 237, to the iconic twenty-four-sphere chandelier, Model 2109. All created from the same fundamental principle that still resonates today with its beautiful interpretation and perfection of a luminous sphere.

To Gino Sarfatti, Le Sfere was a multifaceted, open-minded luminaire system, suitable for illuminating all kinds of spaces with its ambient moonlight, from a modest corridor to exclusive private and commercial settings.

Gino Sarfatti gradually expanded the collection to fit larger commissioned projects. Among them is the famous Teatro Regio in Turin, Italy, where Le Sfere can still be seen in a variety of compositions, including cascades and columns, that emphasise the genius and beauty of the system.



**Model 237**  
**Model 238**





**Model 2109**





# Model 2109

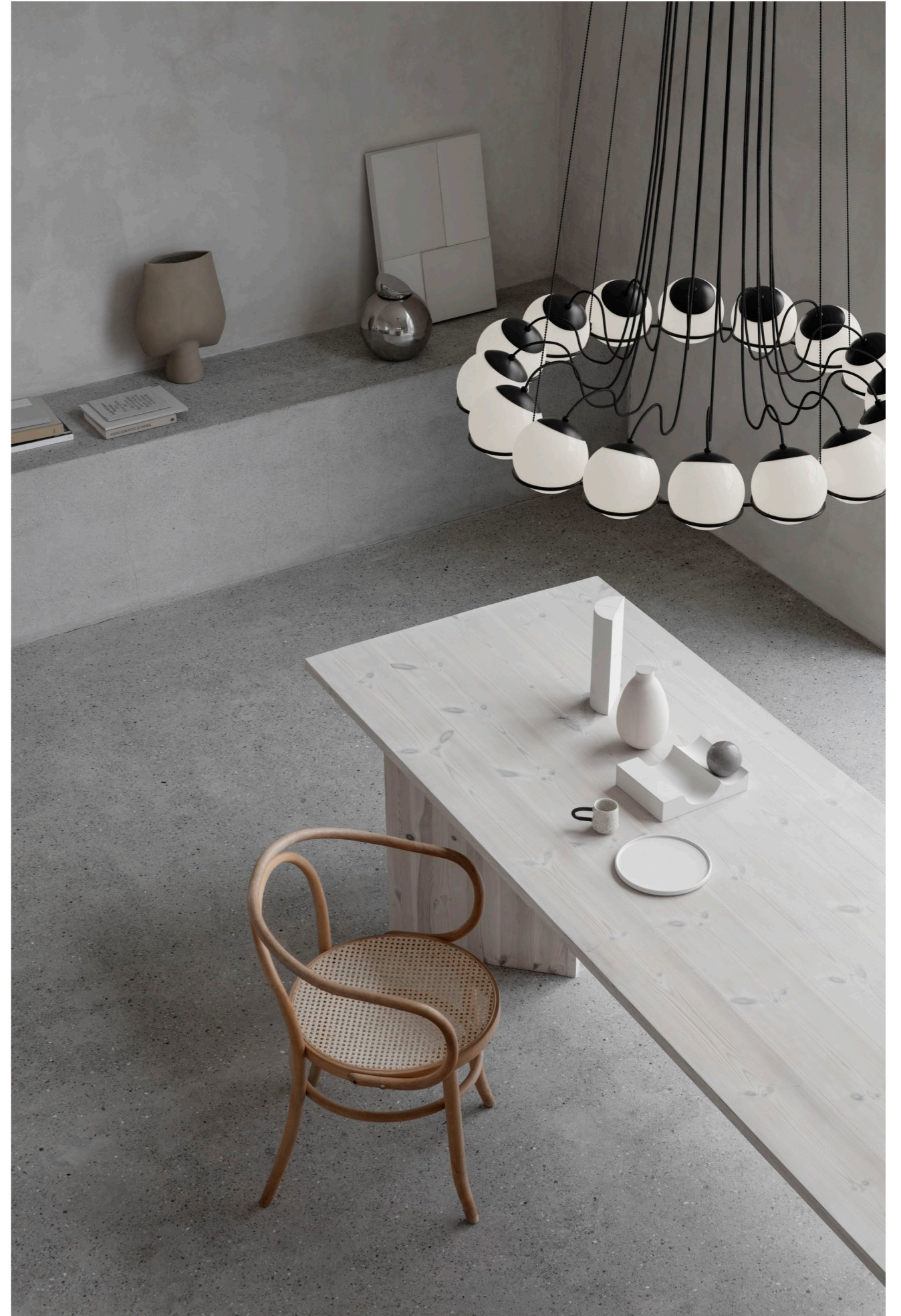

WITH

# Model 2042







## Model 2065

The suspension lamp designed in 1950 emphasises the innovative, experimental approach of Gino Sarfatti. At that time, the favoured material of the lighting industry was glass. But when Gino Sarfatti received the first samples of methacrylate in 1949–50, a new polymer plastic that was much stronger and lighter than glass, his experiments led him to a new suspension lamp, Model 2065. As in so many of his designs, he continued to work with different compositions, dimensions and colour variants over the following years.

Model 2065 consists of a diffuser made of two joined opalescent saucers, suspended from the ceiling with a black-painted aluminium canopy. The simplicity of Gino Sarfatti's elliptical design and the lightness of the materials make for a seemingly weightless luminaire.

The luminaire was relaunched by Astep in 2016, which also introduced a black version where the upper saucer is finished with a soft-touch coating. This leaves the lower diffuser as the only light source, creating a more intimate light space and a strong, graphic expression. In a continuation of the original idea, five LED-bulbs provide the lighting in all versions.





# Model 2065





WITH

## Model 2129

The droplight luminaire designed in 1969 is a beautiful example of Gino Sarfatti's visionary design. A versatile, functional artwork that makes a powerful statement and brings attention to everything its light touches.

The intimate light provided by Model 2129 wraps the space in a warm ambience. The luminaire features a discreet counterweight and a large arc-shaped arm in transparent methacrylate that is attached to the ceiling and able to rotate 360 degrees horizontally.

The cup-shaped reflector is made of two lathed aluminium pieces painted white and caviar grey. Both the dowel for the ceiling fitting and the counterweight are made of painted brass.

In the re-issue, the original light source – an incandescent bulb – is replaced with LED lighting.



**Model 2129**





## Model 1063

The floor lamp designed in 1954 was a true avant-garde design at the time, and with its minimalistic silhouette, it continues to complement even the most modern setting. In Model 1063, Gino Sarfatti seeks to demonstrate the aesthetic value of a visible light source, the fluorescent tubular bulb, and more luminaires and models followed the first ornamental example in the subsequent years.

Emitting direct or reflected light, the floor lamp is composed of a thin black or white-painted aluminium tube, which houses the light source. The aluminium base is balanced by an

aluminium box, a rounded rectangular section that contains the power supply. The two parts are connected via two steel rods arranged in an unusual off-centre position that appears to estrange them from each other while at the same time lending the luminaire a sense of equilibrium in a seemingly magical way.

In the re-issue, the original fluorescent tube has been replaced with an LED module with variable temperature regulation as well as a light dimming function.

WITH

# Model 1063

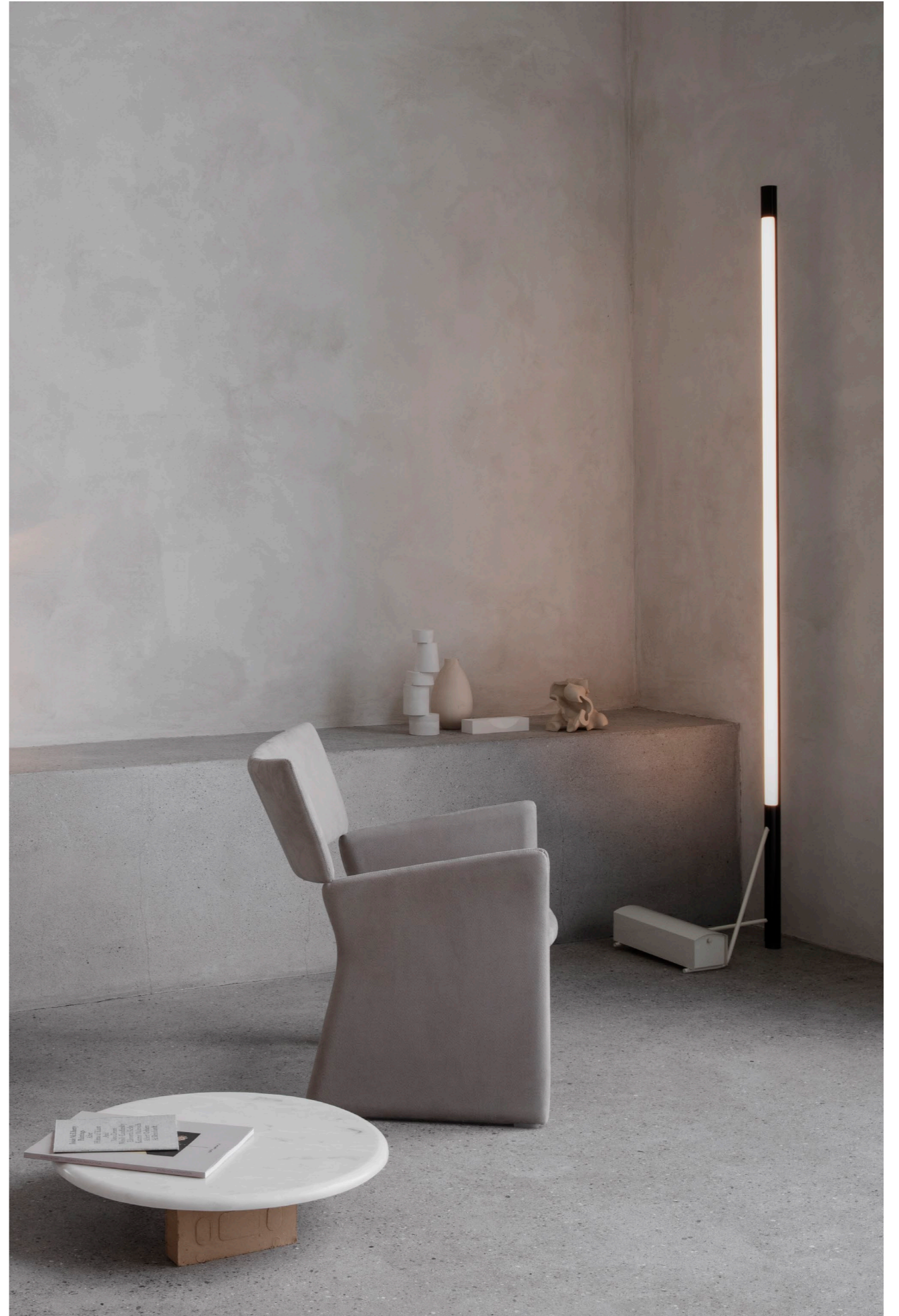



WITH

## Model 1095

The floor lamp designed in 1968 is slender, graceful and intriguing in its disproportions between head and base. The design of the small reflective cup is strongly influenced by the new halogen light bulb, which Gino Sarfatti explored and celebrated in Model 1095 from both a functional and a dimensional perspective.

Offering indirect light in a subtle design, the luminaire is made up of a tubular aluminium stem available in three different heights and painted

slate grey. The small reflective cup with its thin shape is made of white-painted aluminium, and so is the base with the appealing soft shape and neat collar.

In the re-issue, the base covers the electronic devices instead of a transformer, and besides LED lighting, the luminaire has also been upgraded with a water cooling system patented by Flos.





**Model 1095**



WITH



## Model 537

The Model 537 table lamp is an outstanding luminaire that displays the virtuosity of Gino Sarfatti. The celebrated Italian master of light created Model 537 around 1950, and the luminous masterpiece is now reintroduced by Astep as part of the prestigious Flos with Sarfatti collection.

In its refined simplicity, Model 537 stands out owing to the combination of rich materials and ingenious, playful design. The large aluminium reflector in black or white is mounted asymmetrically on a burnished or polished brass stem, which is carefully twisted in a beautiful balancing act, coming to rest on an elegant mar-

ble base. As a vital part of the design, the stem reaches out through the reflector and beyond in a backward motion, giving the top of the stem a dual function as playful feature and practical handle.

While the integrated handle has become a frequent feature in today's designs, Gino Sarfatti was clearly ahead of his time. This was one of the great Italian master's visions: to make light portable. Model 537 is effortlessly carried by hand from the desk in the home office to the living room, the bedroom or any other setting that calls for diffused light in an extraordinary design.



**Model 537**

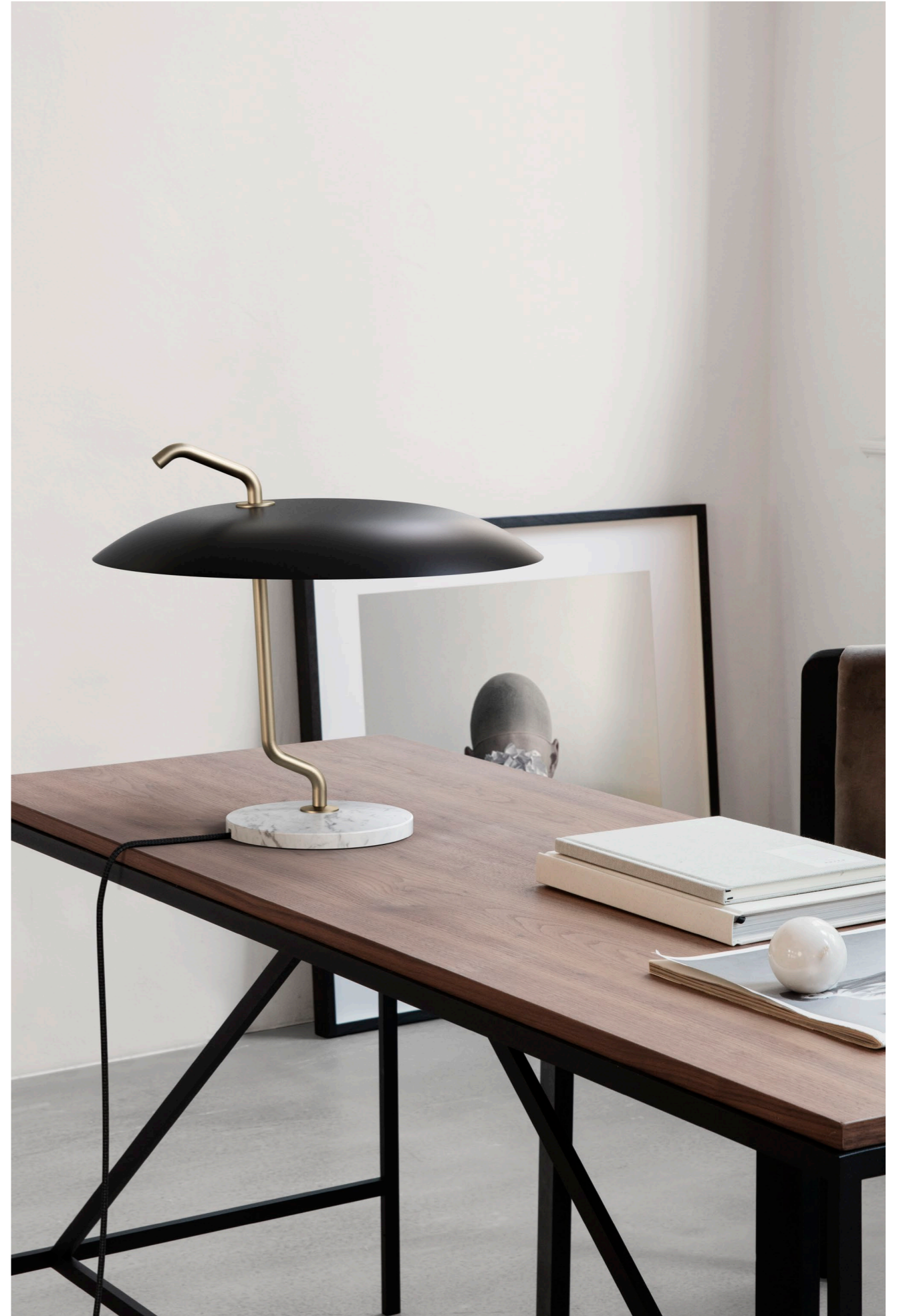

WITH



## Model 548

The table lamp designed in 1951 is a study in balance and light reflection through a screen, a recurring theme in Gino Sarfatti's work. Model 548 provides both reflected and diffused light due to the adjustable spotlight that is directed up towards a reflecting screen.

The large diffuser in orange, blue or grey methacrylate provides a highly sophisticated light effect and is an essential part of the illusion and the play with perception. The spotlight in white

painted aluminium is mounted on a tubular stem in polished or dark burnished brass, while a small brass bar at the base serves as a counterweight in the beautiful balancing act of the individual elements of Model 548.

In the re-issue, the original incandescent bulb has been replaced by an LED source, and an optical dimmer switch has been integrated discreetly into the original design.



**Model 548**





WITH

## Model 607

The table lamp designed in 1971 embodies Gino Sarfatti's working method, where formal experimentation and technical innovation are closely linked. The luminaire is born from a desire to fit a halogen light bulb, a new light source at the time, and its transformer into a table lamp. The result, Model 607, is an outstanding design expression.

This unique piece emits direct light and is made up of two elements mechanically snapped together: a flat, disc-shaped diffuser with a truncated cone section and an inclined parallelepi-

ped base which gives the luminaire stability. Both elements are in painted aluminium, the diffuser with the special crackled finish so appreciated by Gino Sarfatti. The dimmer switch is placed at the front near the foot of the base.

In the re-issue, the Model 607 has been upgraded with modern LED technology in an appreciation of the ultra-modern design.



# Model 607

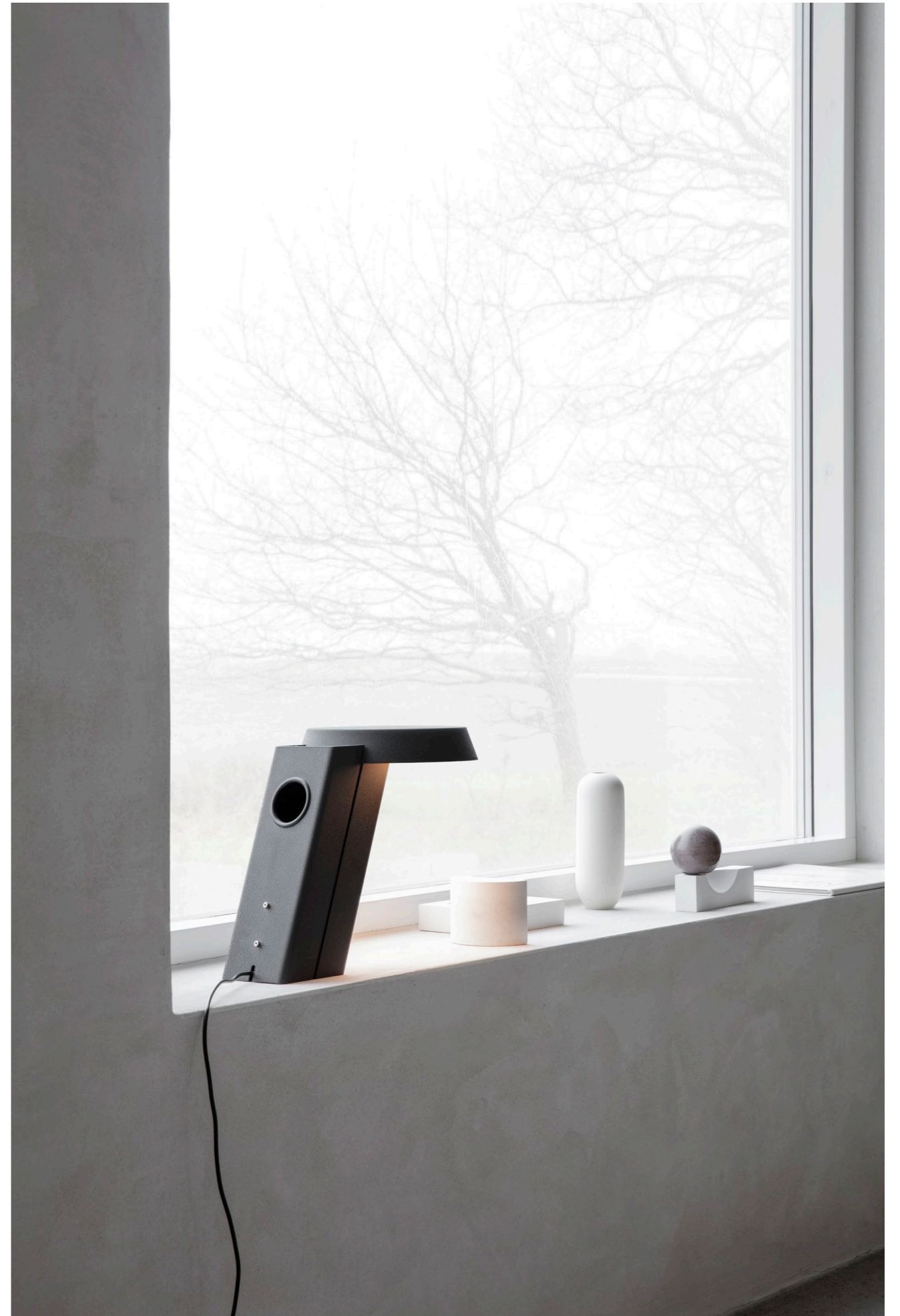

WITH



WITH

## Gino Sarfatti

### Designer (1912-1985)

In 1939, Gino Sarfatti founded Arteluce and brought lighting into the 20th century with a resounding combination of innovative ideas and ground-breaking design. For many years, Arteluce was a creative meeting place for talented Italian architects, among them Vittoriano Viganò, who became a lifelong friend. Gino Sarfatti and Arteluce received numerous awards, including the Compasso d'Oro (1954 and 1955) and the Honorary Diploma of the Milan Triennale.

Originally, Gino Sarfatti studied to become an aeronautical engineer. Family circumstances compelled him to relocate to Milan, where an encounter with lighting design – an engineering project to transform a glass vase into a lamp – not only shaped the path of his own life but also turned out to have an immense influence on the evolution of Italian design practice. Gino Sarfatti is remembered as a visionary entrepreneur and pioneer of Italian lighting design.

Throughout his career, Gino Sarfatti was committed to exploring new materials, product typologies and lighting sources as well as artisanal techniques, leading to the creation of more than 600 luminaires in his name. His hybrid talent as a designer and engineer enabled him to create sophisticated state-of-the-art lighting with regard to both function and aesthetics. The extraordinary 'Model 2097' suspension luminaire from 1958 is one of his most celebrated designs.

In late 1973, Gino Sarfatti decided to sell Arteluce to Flos and retired to his house on Lake Como where he passed away in 1985. His design and significance, however, remain vibrant, upheld by design connoisseurs, private collectors and museums worldwide and now also revived by his grandson Alessandro Sarfatti and Flos in the new capsule collection 'Flos with Sarfatti'.



# Technical Sheets

### MODEL 237/1

Gino Sarfatti, 1959/2018

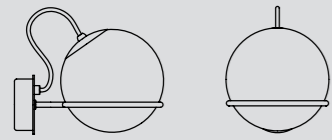

**Typology** Wall  
**Materials** Opaline Glass Diffuser, Steel Structure  
**Dimensions** 140 x 203 x 150mm  
**Diffuser diameter** Ø 140mm  
**Control** Available with On/Off Switch  
**Light source** E14 LED 4.5W, 2700K, 470lm  
 Non-Dimmable Bulb Included  
**Finish**



Item Code	Description	Weight
T08-W31-S180	1 Opaline Sphere, Black Mount	0.85kg
T08-W31-S1D0	1 Opaline Sphere, Champagne Mount	0.85kg
T08-W3S-S180	1 Opaline Sphere, Black Mount with Switch	1.02kg
T08-W3S-S1D0	1 Opaline Sphere, Champagne Mount with Switch	1.02kg

### MODEL 238/1

Gino Sarfatti, 1959/2018

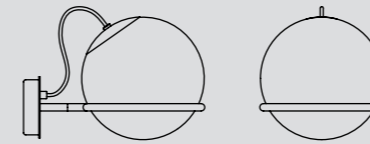

**Typology** Wall  
**Materials** Opaline Glass Diffuser, Steel Structure  
**Dimensions** 200 x 300 x 210mm  
**Diffuser diameter** Ø 200mm  
**Control** Available with On/Off Switch  
**Light source** E27 LED 6W, 2700K, 806lm  
 Non-Dimmable Bulb Included  
**Finish**



Item Code	Description	Weight
T08-W21-M180	1 Opaline Sphere, Black Mount	1.55kg
T08-W21-M1D0	1 Opaline Sphere, Champagne Mount	1.55kg
T08-W2S-M180	1 Opaline Sphere, Black Mount with Switch	1.75kg
T08-W2S-M1D0	1 Opaline Sphere, Champagne Mount with Switch	1.75kg

WITH

### MODEL 237/2

Gino Sarfatti, 1959/2018

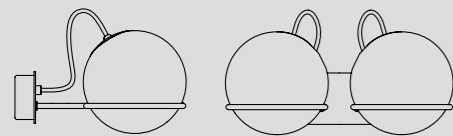

**Typology** Wall  
**Materials** Opaline Glass Diffuser, Steel Structure  
**Dimensions** 310 x 230 x 150mm  
**Diffuser diameter** Ø 140mm  
**Weight** 1.60kg  
**Control** Available with On/Off Switch  
**Light source** 2 x E14 LED 4.5W, 2700K, 470lm (940lm Total)  
 Non-Dimmable Bulbs Included  
**Finish**



Item Code	Description
T08-W31-S280	2 Opaline Spheres, Black Mount
T08-W31-S2D0	2 Opaline Spheres, Champagne Mount

### MODEL 238/2

Gino Sarfatti, 1959/2018



**Typology** Wall  
**Materials** Opaline Glass Diffuser, Steel Structure  
**Dimensions** 450 x 320 x 210mm  
**Diffuser diameter** Ø 200mm  
**Weight** 3.00kg  
**Control** Available with On/Off Switch  
**Light source** 2 x E27 LED 6W, 2700K, 806lm (1612lm Total)  
 Non-Dimmable Bulbs Included  
**Finish**



Item Code	Description
T08-W21-M280	2 Opaline Spheres, Black Mount
T08-W21-M2D0	2 Opaline Spheres, Champagne Mount

**MODEL 2109/16/14**

Gino Sarfatti, 1959/2018

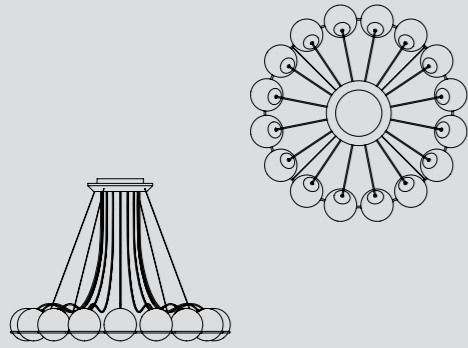

**Typology** Suspension  
**Materials** Opaline Glass Diffuser, Steel Structure  
**Dimensions** Ø 950 x 70-1800mm  
**Diffuser diameter** Ø 140mm  
**Weight** 11.40kg  
**Light source** 16 x E14 (60W Max)  
 Bulbs Not Included  
**Finish**



Item Code	Description
T08-S31-SGB0	16 Opaline Spheres, Black Structure
T08-S31-SGD0	16 Opaline Spheres, Champagne Structure

**MODEL 2109/24/14**

Gino Sarfatti, 1959/2018

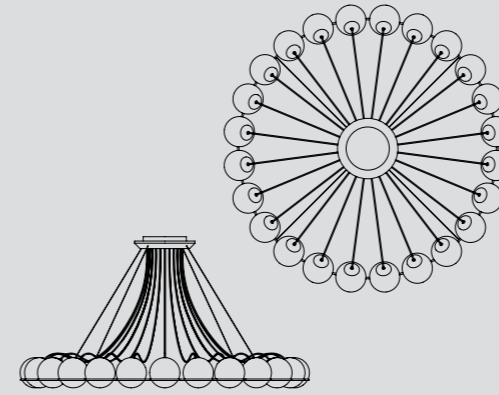

**Typology** Suspension  
**Materials** Opaline Glass Diffuser, Steel Structure  
**Dimensions** Ø 1340 x 70-1800mm  
**Diffuser diameter** Ø 140mm  
**Weight** 16.50kg  
**Light source** 24 x E14 (60W Max)  
 Bulbs Not Included  
**Finish**



Item Code	Description
T08-S31-SOB0	24 Opaline Sphere, Black Structure
T08-S31-SOD0	24 Opaline Sphere, Champagne Structure

WITH

**MODEL 2109/16/20**

Gino Sarfatti, 1959/2018

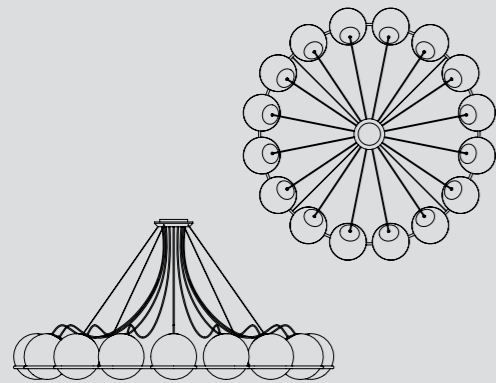

**Typology** Suspension  
**Materials** Opaline Glass Diffuser, Steel Structure  
**Dimensions** Ø 1400 x 70-1800mm  
**Diffuser diameter** Ø 200mm  
**Weight** 21.00kg  
**Light source** 16 x E27 (60W Max)  
 Bulbs Not Included  
**Finish**



Item Code	Description
T08-S21-MGB0	16 Opaline Spheres, Black Structure
T08-S21-MGD0	16 Opaline Spheres, Champagne Structure

**MODEL 2042/6**

Gino Sarfatti, 1959/2018

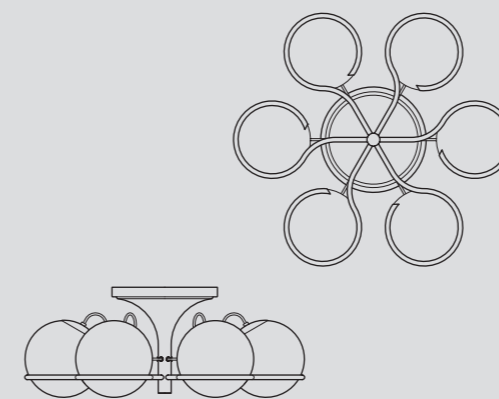

**Typology** Ceiling  
**Materials** Opaline Glass Diffuser, Steel Structure  
**Dimensions** 730 x 658 x 287mm  
**Diffuser diameter** Ø 200mm  
**Weight** 9.40kg  
**Light source** 6 x E27 LED 6W, 2700K, 806lm (1612lm Total)  
 Non-Dimmable Bulbs Included  
**Finish**



Item Code	Description
T08-C21-M6B0	6 Opaline Spheres (20cm Diameter), Black Mount
T08-C21-M6C0	6 Opaline Spheres (20cm Diameter), Champagne Mount

### MODEL 2065

Gino Sarfatti, 1950/2016

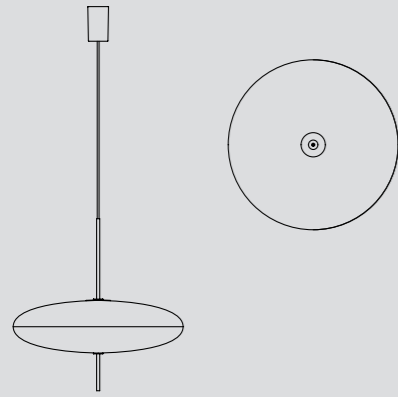

**Typology** Suspension  
**Materials** Opaline Methacrylate Diffusers, Aluminium Hardware  
**Dimensions** Ø 538 x 546mm  
**Diffuser diameter** Ø 538mm  
**Weight** 2.70kg  
**Light source** 5 x E14 LED 4W, 2700K, 470lm (2350lm Total)  
 Dimmable Bulbs Included  
**Finish**



Item Code	Description
T01-S31-0BBW	Black & White Diffuser, Black Hardware, Black Cable
T01-S31-0BWW	White Diffuser, Black Hardware, Black Cable
T01-S31-0WWW	White Diffuser, Black Hardware, White Cable

### MODEL 1063

Gino Sarfatti, 1954/2013

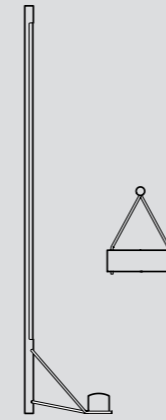

**Typology** Floor  
**Materials** Aluminium Structure, Steel Counterweight  
**Dimensions** H 2150mm, W 350mm, L 460mm  
**Diffuser diameter** Ø 200 mm  
**Weight** 21.00kg  
**Control** Rotary Dimmer  
**Light source** Integrated LED 57W, 2700-5000K, 2500lm  
**Finish**



Item Code	Description
T05-F12-000B	Black with White Base

WITH

### MODEL 2129

Gino Sarfatti, 1969/2013

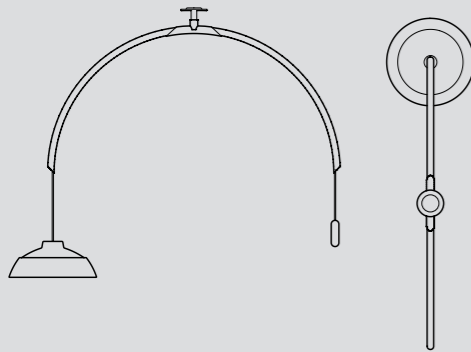

**Typology** Suspension  
**Materials** Aluminium Reflectors, Methacrylate and Brass Struc.  
**Dimensions** 400 x 1450 x 1235mm  
**Reflector Diameter** Ø 400mm  
**Weight** 4.60kg  
**Control** Foot Switch  
**Light source** Integrated LED 25W, 2700K, 1600lm  
**Finish**

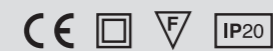

Item Code	Description
T07-S12-00BW	White & Grey Shade, Methacrylate Structure

### MODEL 1095

Gino Sarfatti, 1968/2013



**Typology** Floor  
**Materials** Aluminium Structure  
**Dimensions** Ø 200 x 1700-2000mm  
**Reflector Diameter** Ø 80mm  
**Control** Foot Switch  
**Light source** Integrated LED 34W, 2700K, 1850lm  
**Finish**



Item Code	Description	Weight
T06-F12-010B	1700mm Height, Black Stem, White Base	5.00kg
T06-F12-020B	1850mm Height, Black Stem, White Base	5.15kg
T06-F12-030B	2000mm Height, Black Stem, White Base	5.30kg

### MODEL 537

Gino Sarfatti, 1950/2019



<b>Typology</b>	Table
<b>Materials</b>	Spun Aluminium reflector, Brass Structure, Marble Base
<b>Dimensions</b>	Ø 400 x 360mm
<b>Reflector diameter</b>	Ø 400mm
<b>Weight</b>	2.10kg
<b>Control</b>	On/Off Switch
<b>Light source</b>	1 x E27, Bulb Not Included
<b>Finish</b>	



Item Code	Description
T09-T21-001B	Brass Structure, Black Reflector, White Marble Base
T09-T21-001W	Brass Structure, White Reflector, White Marble Base

### MODEL 607

Gino Sarfatti, 1971/2013

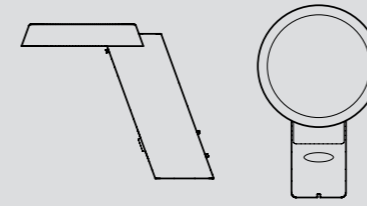

<b>Typology</b>	Table
<b>Materials</b>	Aluminium
<b>Dimensions</b>	250 x 390 x 310mm
<b>Reflector diameter</b>	Ø 250mm
<b>Weight</b>	6.10kg
<b>Control</b>	Rotary Dimmer
<b>Light source</b>	Integrated LED, 11W, 2700K, 730lm
<b>Finish</b>	



Item Code	Description
T04-T12-000G	Grey

WITH

### MODEL 548

Gino Sarfatti, 1951/2013

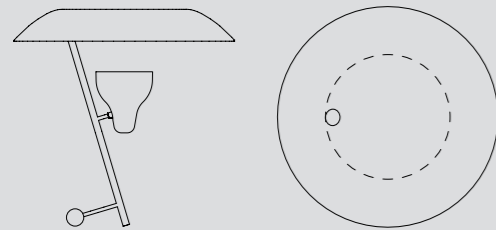

<b>Typology</b>	Table
<b>Materials</b>	Brass Structure, Opaline Methacrylate Diffuser
<b>Dimensions</b>	Ø 500 x 500mm
<b>Diffuser diameter</b>	Ø 500mm
<b>Weight</b>	3.10kg
<b>Control</b>	Touch Dimmer
<b>Light source</b>	Integrated LED, 11W, 2700K, 730lm
<b>Finish</b>	



Item Code	Description
T03-T12-00BG	Dark Burnished Brass with Grey Diffuser
T03-T12-00BO	Dark Burnished Brass with Orange Diffuser
T03-T12-001A	Polished Brass with Azure Diffuser
T03-T12-001G	Polished Brass with Grey Diffuser

FLOS

**Astep is the sole worldwide distributor  
of the Flos with Sarfatti collection**

Astep ApS

Vermundsgade 40B ST  
2100 Copenhagen Ø Denmark

+45 70 70 50 01

[www.astep.design](http://www.astep.design)

For sales inquiries please contact  
[sales@astep.design](mailto:sales@astep.design)

Astep reserves the right to introduce any changes  
to its own models without prior notice



Copyright Astep 2019

PHOTOGRAPHY  
Jonas Bjerre-Poulsen  
Heidi Lerkenfeldt  
Steffen Stamp

STYLING  
Sofie Brunner  
Pernille Vest

GRAPHIC DESIGN  
Michael Kornmaaler  
Francesco Barbaro

SPECIAL THANKS  
Dep Design Store - Como, Italy  
Karakter Copenhagen  
Doriana De Petris  
Lerkenfeldt Gallery  
Maja Karen, artist  
Patrizia Cassina, artist

WITH

SARFATTI

FLOS with Sarfatti

+45 70 70 50 01  
www.asteptdesign  
info@asteptdesign  
sales@asteptdesign

Astep ApS  
Vermundsgade 40B  
2100 Copenhagen  
Denmark

**collection**  
**2019**