

Cassina

ita—eng



Cassina

The Other Conversation 2018

ita—eng

The Other Conversation

2018

Cassina

The Other Conversation

Contenuti/Contents

Divani/Sofas

14

Bowy-Sofa
Patricia Urquiola

40

Refolo
Charlotte Perriand

90

Miloe
Piero Lissoni

148

Privé
Philippe Starck

20

Beam Sofa System
Patricia Urquiola

58

8 Cube
Piero Lissoni

116

Mex Cube
Piero Lissoni

160

Myworld
Philippe Starck

33

Lady
Marco Zanuso

62

Maralunga
Vico Magistretti

126

Volage EX—S
Philippe Starck

36

8
Piero Lissoni

80

Maralunga 40 Maxi
Vico Magistretti

138

Met
Piero Lissoni
with S. Sook Kim



Poltrone/Armchairs

26

Gender
Patricia Urquiola

79

LC2
Le Corbusier, P. Jeanneret,
C. Perriand

130

Utrecht
Gerrit Thomas Rietveld

164

Wink
Toshiyuki Kita

31

Lady
Marco Zanuso

112

P22
Patrick Norguet

143

Red and Blue
Gerrit Thomas Rietveld

198

Cotone
Ronan & Erwan Bouroullec

53

LC4
Le Corbusier, P. Jeanneret,
C. Perriand

121

LC3
Le Corbusier, P. Jeanneret,
C. Perriand

146

Tre Pezzi
Franco Albini

200

Cotone Slim
Ronan & Erwan Bouroullec

Sedie/Chairs

18

905
Vico Magistretti

156

Zig Zag
Gerrit Thomas Rietveld

34

Ico
Ora-ïto

186

Hola
Hannes Wettstein

87

Back-Wing
Patricia Urquiola

193

Tulu
Kazuhide Takahama

197

Superleggera
Giò Ponti

201

Cotone Legno
Ronan & Erwan Bouroullec

196

Leggera
Giò Ponti

211

Cab
Mario Bellini

Tavoli/Tables

46

9
Piero Lissoni

97

Tabouret Berger/Méribel
Charlotte Perriand

172

Ordinal
Michael Anastassiades

202

Cotone
Ronan & Erwan Bouroullec

71

Rio
Charlotte Perriand

98

LC14
Le Corbusier

176

LC6
Le Corbusier, P. Jeanneret,
C. Perriand

212

La Rotonda
Mario Bellini

74

LC10—P
Le Corbusier, P. Jeanneret,
C. Perriand

99

LC14 Tabouret Nantes Rezé
Le Corbusier

182

Naan
Piero Lissoni

204

Doge
Carlo Scarpa

88

Mexique
Charlotte Perriand

124

Torei
Luca Nichetto

188

Boboli
Rodolfo Dordoni

Contenitori e librerie/ Container units and Bookshelves

42

Nuage
Charlotte Perriand

67

Casiers Standard
Le Corbusier, P. Jeanneret,
C. Perriand

109

Infinito
Franco Albini

167

Nuvola Rossa
Vico Magistretti

57

Veliero
Franco Albini

Complementi/ Accessories

100

Réaction Poétique
Jaime Hayon

217

**Tappeti/
Rugs**

134

Deadline
Ron Gilad

220

**Cuscini/
Cushions**

Appendici/Appendix

222

**Marchiatura/
Identifying
marks**

224

**Disegni Tecnici/
Technical
Drawings**

242

**Abaco/
Models Table**

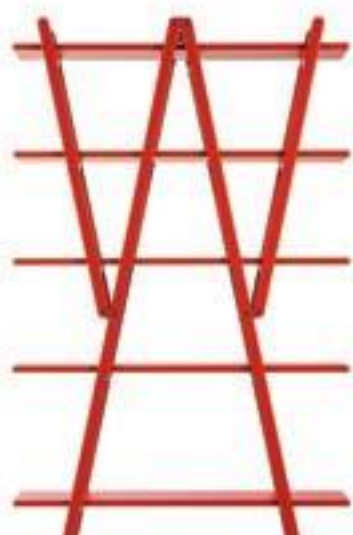



This is Cassina

ITA

Il mondo Cassina riflette il percorso di un'azienda intuitiva e lungimirante, che per prima, negli anni '50, ha inaugurato l'era del design industriale in Italia, segnando il passaggio dalla produzione artigianale a quella seriale. Un'azienda che ha sempre saputo precorrere i tempi con attitudine pionieristica, arrivando a coinvolgere i più rinomati designer e architetti nella creazione di nuove forme che raccontano le molteplici ispirazioni e influenze della progettazione contemporanea. Ricerca, sapienza manuale e sviluppo tecnologico si incontrano nelle diverse proposte dedicate alla casa e all'arredo di spazi architettonici su larga scala, abbracciando una filosofia di passione e perfezione che svela tutta la sua eccellenza nella lavorazione degli imbottiti, esaltati da linee confortevoli, essenziali, flessibili e sorprendentemente innovative. In un continuo confronto tra passato, presente e futuro, l'azienda presenta al mondo i grandi classici dei più grandi architetti del XX secolo, rieditando le icone della modernità nella collezione I Maestri, fondata sull'accuratezza e sul rispetto dei progetti iniziali. Le espressioni che hanno contribuito all'evoluzione del design dagli anni '50 ad oggi rivivono nella collezione I Contemporanei, in cui i modelli iconici del Made in Italy scoprono nuove interpretazioni e declinazioni all'interno di diversi habitat. L'approccio sperimentale di Cassina emerge poi, con significativa progettualità, nella SimonCollezione, composta dagli oggetti più emblematici del rapporto tra cultura e industria nel design italiano. I valori di autenticità, maestria, avanguardia e cultura sono orgogliosamente racchiusi nel logo MedaMade, simbolo di una produzione locale e di una qualità artigianale di grande tradizione, che distingue ogni prodotto Cassina per la sua unicità, originalità e assoluta riconoscibilità.

ENG

The world of Cassina is the story of a farsighted and intuitive company: the first to usher into Italy the era of industrial design in the 1950s, marking the shift from handcraftsmanship to serial production. Driven by a pioneering vision, the company has always been ahead of its time, successfully attracting talented designers and architects in the making of new shapes, spurred by many inspirations and influences of contemporary design. Research, artisanal expertise and technological development come together in the wide range of offerings for the home and large-scale architecture. A philosophy of passion and perfection unveils its excellence in the production of upholstered furniture, enhanced by high-comfort, essential, versatile and strikingly innovative designs. Continuing its connection between past, present and future, Cassina presents to the world the great classics of the most important architects of the twentieth century, relaunching the icons of modernity in the

collection I Maestri, based upon accuracy and full respect of the original projects. The expressions that have traced the history of design from the fifties to the present day live on in the Contemporary collection, where iconic Made in Italy pieces find new interpretations and variations within different environments. Cassina's more experimental approach emerges masterfully in the SimonCollezione, comprising of some of the most representative objects of the relationship between culture and industry in Italian design. The values of authenticity, excellence, avant-gardism and culture are proudly encapsulated in the MedaMade logo: the unmistakable symbol of local production and quality of craftsmanship and tradition, which distinguishes each Cassina product by its uniqueness, originality and absolute recognizability.

↳

Sofa Craftsmanship

Pensare e realizzare la perfezione/Conceiving and creating perfection

6



2016
Beam Sofa System,
Patricia Urquiola

Un sistema di sedute morbide sorretto da una trave cela un meccanismo flessibile di schienale e braccioli in omaggio al lavoro di Vico Magistretti.

A soft seating system supported by a beam hides a flexible backrest and armrest mechanism that pays homage to the work of Vico Magistretti.



2015
Lady,
Marco Zanuso

Un'icona della modernità nata nel 1951 con l'innovativo accoppiamento della gommapiuma con il molleggio. Resa oggi ancora più contemporanea grazie a una nuova selezione di tessuti.

A modern icon created in 1951 with the innovative pairing of foam rubber and springs. Now made even more contemporary with a new selection of fabrics.

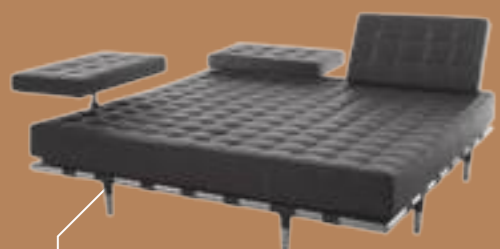

2008
Privé,
Philippe Starck

Provocazione e ironia, tradizione e ricerca tecnologica. Elementi innovativi nella lavorazione del capitonné diventano con questo modello un brevetto internazionale.

Provocation and irony, tradition and technological research. With this model, the innovative elements of capitonné process become an international patent.



2015
LC5,
Le Corbusier, Pierre Jeanneret,
Charlotte Perriand

Il divano secondo Le Corbusier: confort e proporzioni contemporanee. Disegnato nel 1934 per la sua casa di Parigi.

The sofa according to Le Corbusier: comfort and contemporary proportions. Designed in 1934 for his home in Paris.



2014
8,
Piero Lissoni

Questo divano modulare con struttura in alluminio presenta un design lineare unito a grande confort.

This modular sofa with aluminium structure combines a slim linear design with great comfort.

7



1980
Tramonto a New York,
Gaetano Pesce

Un oggetto di design come veicolo di comunicazione. Sedili e braccioli come i grattacieli di New York e uno schienale che materializza il sole rosso al tramonto. Una riflessione sull'habitat dell'uomo.

A design object as a means of communication. Seats and armrests like the skyscrapers of New York and a backrest that represents the red sun at dusk. A reflection on the human habitat.

1970
Soriana,
Afra and Tobia Scarpa

Un importante riconoscimento, il Compasso d'Oro, per un divano nato dalle innovative ricerche sul poliuretano espanso.



Awarded the Compasso d'Oro prize, this sofa received important recognition for its innovative research of polyurethane foam.

The Other Conversation Brochure



1973
Maralunga,
Vico Magistretti

Oggetto di grande impatto sul mercato internazionale, questo progetto fu rivoluzionario grazie all'inserimento di una semplice catena da bicicletta che permette allo schienale di assumere posizioni differenti.

An object that has had a major impact on the international market, this project was revolutionary due to the insertion of a simple bicycle chain that made it possible to adjust the backrest to different positions.



1953
mod. 812,
Ico Parisi

Il divano moderno. Coniugazione di eleganza e nuova spazialità.

A modern sofa that unites elegance and a new use of space.

This is Cassina

Authenticity

Accuratezza e massimo rispetto del Progetto originale/High respect for the original project with the needed precision that comes with it

8



2013

Cassina e Simon Collezione: le radici del design italiano

Cassina acquisisce il marchio Simon fondato nel 1968 da Dino Gavina e Maria Simoncini, confermando il proprio ruolo di portavoce delle radici del moderno design Italiano.

Cassina and Simon Collezione: the roots of Italian design

Cassina acquires the Simon Collezione brand, founded in 1968 by Dino Gavina and Maria Simoncini, confirming its role as spokesperson for the roots of modern Italian design.

Cassina *simon*
COLLEZIONE



1965

La filosofia della ricostruzione

La proposta al mercato di oggetti d'arredo ricostruiti con il rigore scientifico sempre nel rispetto dell'autenticità della documentazione originale.

The reconstruction philosophy

A range of furniture reconstructed with scientific precision while respecting the authenticity of the original designs.

The Other Conversation Brochure

2015—2017

C90. Cassina rilegge le proprie icone

In occasione dei 90 anni, Cassina fa una riflessione sulla propria storia proponendo nuove versioni dei suoi modelli più significativi. Tra questi la poltrona mod. 932 di Mario Bellini del 1967.



C90. Cassina revisits its Icons

To mark its 90th anniversary, Cassina looks back at its history with new versions of its most significant models. These include the mod. 932 armchair by Mario Bellini from 1967.



1953

Un nuovo marchio aziendale

Il nuovo logo dell'azienda disegnato da Giancarlo Pozzi.



A new company logo

The new company logo, designed by Giancarlo Pozzi.

1991
Compasso d'oro

Il massimo riconoscimento del design attribuito a Cassina per il suo contributo alla ricerca e all'innovazione della produzione industriale.



The most high-profile design award, awarded to Cassina for its contribution to research and innovation in industrial design.

1965

Collezione Cassina I Maestri

A garanzia della sua autenticità, ogni mobile della Collezione Cassina I Maestri porta impressa una marchiatura che comprende la firma degli autori, il nome del modello, il numero progressivo di produzione e il logo Cassina I Maestri.

Cassina iMaestri Collection

As a guarantee of its authenticity, each piece of furniture in the Cassina iMaestri Collection is branded with the signature of its designers, the name of the model, its serial number and the Cassina iMaestri logo.



1927

Cassina Amedeo Fabbrica tavolini

Dalla tradizione di alta ebanisteria della famiglia Cassina nasce a Meda la Fabbrica di tavolini Amedeo Cassina.

The Amedeo Cassina cabinet making carpentry is opened in Meda, following on from the exacting woodwork tradition of the Cassina family.



2012

Materiali Autentici

Il rispetto della qualità, delle potenzialità e dei limiti dei materiali, lavorati spesso con modalità innovative. Ogni nuovo mobile è anche un progetto che sfida i limiti del convenzionale.

Authentic Materials

Respect for the quality, potential and limits of the materials, often processed using innovative methods. Every new piece is also a project that pushes the boundaries of convention.

1966

C&B, Cassina e Busnelli

Una nuova azienda fondata da Cesare Cassina e Piero Busnelli per la sperimentazione e l'applicazione di materiali schiumati innovativi.

C&B, Cassina and Busnelli

A new company founded by Cesare Cassina and Piero Busnelli for experimenting with and applying innovative foam materials.



9

This is Cassina

Pioneer

Lungimiranza, sperimentazione e attitudine pionieristica/Farsightedness, experimentation and a pioneering spirit

10

2014
M10,
Patrick Norguet

Una sfida progettuale importante. Una seduta sospesa resa possibile dal know-how tecnico di Cassina in un processo di lavorazione complesso e rivoluzionario.

A major design challenge. A suspended chair made possible by the technical knowhow of Cassina in a complex, revolutionary production process.



1998
L.W.S.,
Philippe Starck

Nuove visioni per l'habitat domestico. Un'isola multifunzionale cablata per vivere i diversi ritmi dell'abitare.

New visions for the home. A multi-purpose cabled island in tune with the different rhythms of domestic life.



1968
Ciprea,
Afra e Tobia Scarpa

Per la prima volta al mondo sono sperimentati nuovi materiali schiumati per la realizzazione di imbottiti.

For the first time, new foam materials are used to produce padding.



2006
Ricostruzione
del Cabanon
di Le Corbusier

Un'operazione di divulgazione culturale dei valori dell'interno architettonico condotta partendo dalla costruzione originale del 1952 a Roquebrune Cap Martin in Francia.

The reconstruction
of Le Corbusier's
Cabanon

An operation for the cultural dissemination of the values of architectural interiors which began with the original construction in Roquebrune Cap Martin, France, in 1952.



1965
Le Corbusier,
P. Jeanneret, C. Perriand

Cassina accetta la sfida di re-editare questi oggetti rivoluzionari, all'epoca sconosciuti, introducendo una serie di innovazioni tecniche. Il successo commerciale della collezione accompagna l'internazionalizzazione dell'azienda, rendendo queste icone rinomate in tutto il mondo.

Cassina accepts the challenge of reworking these revolutionary articles, unknown at the time, with the introduction of a series of technical innovations. The collection's commercial success accompanies the company's internationalisation, bringing these icons worldwide fame.

1957
699 Superleggera,
Gio Ponti

La maestria di Cassina incontra il genio di Gio Ponti. Nasce una sedia in legno di 1,7 kg leggera e fortissima. Fondamentale icona del design italiano nel mondo.

The expertise of Cassina meets the genius of Gio Ponti. The result is a wooden chair weighing just 1.7 kg, light yet very sturdy. A key icon of Italian design across the world.



2011
Veliero,
Franco Albini

Una sfida ardua alle leggi della statica. L'unico esemplare del 1940 torna a vivere grazie all'intensa ricerca svolta da Cassina, in collaborazione con un team di esperti, sull'utilizzo di tecnologie contemporanee nel rispetto dell'anima autentica di un progetto sperimentale.

A bold challenge to the laws of statics. The only example from 1940 is brought back to life thanks to intense research by Cassina, in partnership with a team of experts in the use of contemporary technologies that respect the authentic spirit of an experimental project.

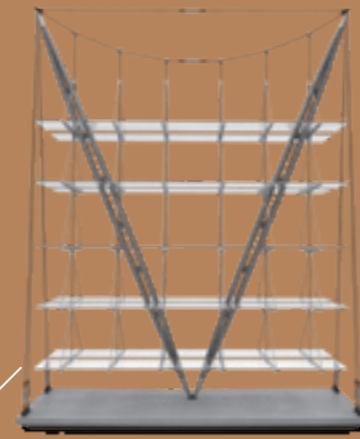

1987
I Feltri,
Gaetano Pesce

Una nuova applicazione brevettata del feltro, una materia che nei tempi lontani, prima del tessuto, proteggeva i corpi umani sia dal caldo che dal freddo.

1977
Cab,
Mario Bellini

Materiali grezzi combinati per la prima volta in modo brillante ed essenziale: un vestito cucito in cuoio, montato su un telaio d'acciaio.

Staple materials brilliantly and essentially combined for the first time: a saddle-leather dress mounted on a steel frame.



1969
Cassina
R&D

Cassina è la prima azienda di mobili a investire nella sperimentazione e nel design avanzato.

Cassina
Research Centre

Cassina is the first furniture company to invest in experimentation and cutting-edge design.



A new patented application for felt, a material which, in the distant past before "fabric", was used to protect human bodies from both the heat and cold.



1952
Andrea Doria

Cassina è in prima linea nella realizzazione delle grandi commesse per il contract. Realizzando gli interni del transatlantico italiano Andrea Doria è la prima a portare il gusto del made in Italy negli Stati Uniti.

Cassina is at the frontline in the production of large-scale orders for the contract sector. It is the first to take the Made in Italy brand to the United States, supplying the interiors for the Italian ocean liner Andrea Doria.



The Other Conversation

ITA

Cassina entra nelle case vere, negli spazi di tutti i giorni, inserendo i suoi prodotti all'interno di ambienti di diverso stile e configurazione, progettati da architetti contemporanei.

Atmosfere reali, con un carattere vivo e vissuto, che diventa sfondo ideale per un nuovo dialogo tra design e architettura, tra designer e architetto, tra gli oggetti e l'habitat domestico.

Interni semplici o ricercati, angoli di relax e creatività, dimensioni del comfort e della convivialità: scene di un viaggio culturale ed emozionale che riflette l'identità versatile, flessibile e funzionale dei divani e delle poltrone Cassina, suggerendone la grande varietà di usi, interpretazioni e libere associazioni.

Sono le icone senza tempo di Cassina, pensate e perfezionate per adattarsi al ritmo e alle esigenze della quotidianità, attraverso materiali, tessuti e dettagli che trovano senso in ogni ambiente. Le linee dinamiche, modulari e accoglienti si uniscono con armonia agli elementi e complementi di varie misure, personalizzando gli spazi con gusto classico o moderno, tradizionale o innovativo, razionale o più estroso.

Forme essenziali e senza tempo, create dai grandi maestri del design, disposte in ambienti che esprimono la continuità tra passato, presente e futuro, accompagnando le parole e i gesti di una conversazione che valorizza l'autenticità, l'accuratezza e l'eccellenza del design Cassina.

ENG

Cassina goes into real homes, into everyday places, featuring its products into domestic settings in different styles and configurations, designed by contemporary architects. Authentic atmospheres with vibrant, lived-in personalities become the ideal backdrop for a new dialogue between design and architecture, designer and architect, objects and home space. Simple or sophisticated interiors, corners to relax or be creative in, zones for comfort and hospitality: scenes of a cultural and emotional journey that reflects the versatile, practical identity of Cassina sofas and armchairs, opening them up to a wide range of uses, interpretations and free associations. These are Cassina's timeless icons, conceived and perfected to adapt to the pace and demands of daily life, thanks to materials, fabrics and details that make sense in any setting. Their dynamic shapes, modular and enveloping, blend

harmoniously with different sized elements and complements, tailoring spaces to a classic or modern, traditional or innovative, exacting or more free-spirited taste. Essential, timeless pieces, created by the great masters of design, set in surroundings that express the continuity between past, present and future, accompanying the words and gestures of a conversation that always enhances the authenticity, accuracy and design excellence of Cassina.

mod. 553

14

Bowy— Sofa

Patricia Urquiola
2018

Rivestimento divano/
Sofa upholstery
Bowy—Sofa



p 15
Annapurna Perla
13F360

Novità/News 2018

ITA

Un divano modulare e giocoso, con curve morbide e accoglienti che associano comfort estremo e massima combinabilità. Il bracciolo tondeggiante si unisce allo schienale sporgente modellato grazie all'eccellenza artigianale di Cassina, particolarmente in evidenza nelle cuciture imbottite che delineano le forme dei vari elementi. Il divano è composto da singoli moduli concepiti come piccole sculture da utilizzare anche separatamente. La struttura metallica, con poliuretano espanso iniettato a densità variabile e rivestimento in dacron, assicura una seduta comoda e generosa. L'ispirazione anni '70 si traduce anche nella proposta di tavolini che riprendono le forme smussate del divano abbinando la struttura laccata all'elegante matericità del piano in legno. Sono progettati come elementi sovrapponibili e intersecabili, che permettono di rompere lo schema della seduta o di vivere singolarmente nello spazio come tavolini da caffè.

ENG

An inventive sectional sofa, with soft, inviting curves that bespeak comfort to the max and extreme versatility. The rounded arm-rests curve to meet the back, the shape expressing the crafts excellence synonymous with Cassina's expertise, more evidence of which can be seen in the upholstery edge-stitching that delineates the lines of

the various elements. The sofa is composed of single units that have been conceived as if they were individual sculptures, so they work equally well as part of a team or as stand-alones. The metal frame is upholstered in injected expanded polyurethane foam, with Dacron covers, to provide a generous and comfortable seat. The 1970s' inspiration

comes through also in the low tables that reflect the sofa's soft profile, the painted frame meeting the elegant material quality of the wooden table-top. Designed to work together, one over the other, or abutting each other, these tables can be used to break up the lines of the sofa, but are equally at home as stand-alone coffee tables.





01

Rivestimento divano/
Sofa upholstery
Bowy-Sofa



Ammapurna Perla
13F360

01 Sedia/Chair 905,
Vico Magistretti 1964 — p 242

01.905
Vico Magistretti 1964

ITA

Prodotta da Cassina fino al 2000, la sedia viene oggi rilanciata aggiornando le finiture e le lavorazioni del modello d'archivio. L'eleganza sofisticata della struttura con gambe cilindriche e braccioli ad arco rivive grazie all'esperienza maturata da Cassina nella lavorazione del cuoio e nella carpenteria di alta qualità. La complessità dell'oggetto, considerato a tutti gli effetti un capolavoro autentico del MedaMade, si traduce in un design apparentemente semplice che riflette appieno la genialità del progetto originale. Il telaio in legno pregiato riflette l'equilibrio fra la tradizione artigianale e l'innovativa tecnologia del controllo numerico, mentre il design si distingue per il sedile autoportante creato con un unico pezzo di cuoio curvato intorno alla struttura. La cucitura decorativa è stata rimossa, mentre la parte posteriore è ancora oggi rifinita con una cintura in pelle che supporta lo schienale ampliando la sensazione di comfort.

Rivestimento sedia/
Chair upholstery
905

Novità/News 2018

p 19

Noce canaletto,
cuoio nero/
American Walnut,
black saddle leather



b

Frassino naturale,
cuoio blu/ Natural
ashwood, blue saddle
leather



d

Frassino naturale,
cuoio rosso bulgaro/
Natural ashwood, russian
red saddle leather



a

Frassino naturale,
cuoio naturale/
Natural ashwood, natural
saddle leather



c

Frassino tinto nero,
cuoio avorio/ Black
stained ashwood, ivory
saddle leather



ENG

01.905
Vico Magistretti
1964

Produced by Cassina until 2000, this chair has now been relaunched, the finishes and details having been updated from the original archive model. The sophisticated elegance of the frame, which features cylindrical legs and curved arm-rests, has been rejuvenated thanks to Cassina's extensive experience in handling leather, not to mention the company's high quality carpentry skills. The complex nature of this piece is expressed in a design that looks simple but fully reflects the genius of the

original concept, a veritable masterpiece of the crafts tradition proper to Meda. The frame, in finest quality wood, bespeaks the perfect combination of the artisanal tradition and premier CNC technology, while the overall design stands out for the self-supporting seat crafted from one single piece of saddle leather, curved and slotted into the frame. The decorative stitching has been removed, while the rear of the chair still features the leather belt that lends support to the back and enhances its comfort quotient.



mod. 550

20

Beam Sofa System

Patricia Urquiola
2016

Rivestimento divano/
Sofa upholstery
Beam Sofa System



p 21
Marocco
13F754

ITA

Il Beam Sofa System è un innovativo sistema di sedute imbottite, poggiate su una trave geometrica, che fonde stile e funzionalità, permettendo di abbinare i diversi elementi e di comporre soluzioni personalizzate con interessanti alternanze fra sedute, tavolini e pouf.

Lo schienale alto, il dettaglio della cucitura lungo il profilo perimetrale, il meccanismo dello schienale e il bracciolo che si sovrappongono, creano un abbraccio confortevole e avvolgente. Progettato dall'architetto e designer spagnola Patricia Urquiola, questo sistema è un autentico omaggio al lavoro di Vico Magistretti: un'interpretazione contemporanea, ricercata e versatile, che esprime il concetto di relax nella cura di ogni dettaglio, volume e movimento.

ENG

Beam Sofa System is an innovative padded seating system, resting on a geometric beam, which combines style and functionality, meaning different elements can be combined and personalised solutions created with interesting

alternations between seating, tables and ottomans. The high backrest, the stitching detail along the edge, the overlapping backrest and armrest mechanism, together create a comfortable, enveloping embrace. Conceived by the Spanish architect

and designer Patricia Urquiola, this system is a real tribute to the work of Vico Magistretti. A contemporary sophisticated and versatile interpretation it expresses the concept of relaxation in its attention to detail, volume and movement.





Rivestimenti/
Upholsteries

 p 22
Gerrit
13O611

 p 23
Marocco
13F754



01

01. Gender

Patricia Urquiola 2016

ITA

Gender è una poltrona, unica nel suo genere. Una combinazione di materiali e di colori per una grande varietà di utilizzi: il morbido interno imbottito dialoga con l'esterno rigido, impreziosito da un bordo colorato in pelle, che ne sottolinea la sinuosità. I tessuti aderiscono alle curve della poltrona e sono proposti in sette diverse combinazioni di colore predefinite. Lo schienale si adatta alla pressione inclinandosi a circa 12° e tornando in posizione automaticamente. È inoltre disponibile un pouf nelle stesse combinazioni, con fascia poggiatesta in pelle, che consente di proteggere la superficie da danneggiamenti. Due "scarpette", in cuoio nero o pelle cangiante, coprono i piedi di Gender per completare il tutto.

Rivestimenti poltrona/
Armchair upholsteries
Gender

p 27

Pelle/Leather
Scozia 13X202
Gerrit 13O609
Gerrit 13O608

a

Pelle/Leather
Naturale 13Z308
Gerrit 13O643
Gerrit 13O625

b

Pelle/Leather
Extra 13Y255
Gerrit 13O644
Gerrit 13O622



a



b

ENG

01. Gender Patricia Urquiola 2016

Gender is an armchair, one of a kind. A combination of materials and colours with a wide range of uses: the soft padded interior converses with the rigid exterior, enhanced by a coloured leather edge that accentuates its sinuosity. The fabrics cling to the curves of the armchair and come in seven different set colour combinations.

The backrest responds to pressure by reclining about 12° and returning automatically to its original position. A pouf is also available in the same combinations, with leather footrest band to protect the surface from any damage. Two end sections in black saddle leather or shimmering leather, cover the feet of Gender to round things off.





Rivestimento divano/
Sofa upholstery
Beam Sofa System

Marocco
13F754



02 Poltrona_Armchair Lady,
Marco Zanuso 1951/2016 — p. 31



Marco Zanuso

1916–2001

ITA

È stato fra i maggiori interpreti della cultura del moderno, come architetto, designer e docente universitario. Formatosi al Politecnico di Milano e, nel primo dopoguerra, condirettore della rivista Domus con Ernesto N. Rogers, ottiene più volte la Medaglia d'oro e il Gran Premio della Triennale di Milano (VIII, IX, X, XI, XIII), e cinque Compassi d'Oro negli anni tra il 1956 e il 1985. Zanuso è stato uno dei primi progettisti in Italia a interessarsi ai problemi dell'industrializzazione del prodotto, andando oltre la questione estetica per incorporare delle variabili di tipo tecnologico, industriale, distributivo e comunicativo. La forma di un oggetto destinato alla riproduzione seriale, secondo Zanuso, è quindi sintesi di opportunità, sperimentazioni e innovazioni situate nel processo concreto che lega creatività, produzione e contesto socioculturale.

ENG

Architect, designer and university lecturer, Marco Zanuso (1916-2001) was one of the leading interpreters of the Modern Movement. Trained at the Polytechnic University of Milan and, in the immediate post-war years, co-editor of the Domus magazine with Ernesto N. Rogers, he was awarded the Medaglia d'oro and the Gran Premio at the Milan Triennale (VIII, IX, X, XI and XIII editions), and won five Compassi d'Oro between 1956 and 1985. Zanuso was one of the first designers in Italy to take an interest in the problems of product industrialisation, going beyond aesthetic issues to incorporate technological, industrial, distribution and communication variables.



1

1. Poltrona Lady, anni '50/Armchair Lady, 50s.



2

2. Marco Zanuso nel suo studio con la poltrona Lady. Dalla rivista Abitare n.7 Marzo 1962/Marco Zanuso in his atelier with the Lady armchair. From Abitare magazine n.7 March 1962.



02. Lady

1951/2016

ITA

Disegnata nel 1951, la poltrona Lady ottenne, nello stesso anno, la medaglia d'oro alla IX Triennale di Milano. La poltrona costituisce l'icona della modernità poiché fu frutto di un'innovazione, che capovolse il sistema tradizionale di lavorazione degli imbottiti: la realizzazione separata delle parti e il loro successivo assemblaggio. Oggi l'estetica della poltrona Lady è stata resa ancora più contemporanea grazie alla nuova selezione di tessuti firmati Raf Simons introdotta nella collezione Everest di Cassina.

ENG

Designed in 1951, the Lady armchair won the gold medal at the IX Milan Triennale in the same year. The armchair stands as a modern icon, the fruit of innovation that turned the traditional manufacturing technique for making armchairs and sofas on its head, with each part manufactured separately and then assembled; seat,

backrests and sides with different padding densities depending on the support required by the pressure exerted by the body. Today, the look of the Lady armchair has been made even more contemporary by a new selection of fabrics designed by Raf Simons and introduced to Cassina's Everest collection.

Rivestimento poltrona/
 Armchair upholstery
 Lady



Everest 2-Pilot
 130119



Lady

Marco Zanuso, 1951/2017

ITA

Alla poltrona, è affiancato un divanetto a due posti che presenta le medesime caratteristiche produttive della poltrona: sedile, schienali e fianchi sono prodotti separatamente e hanno gradi di imbottitura diversi a seconda delle esigenze di sostegno che esercita la pressione del corpo. Come per la poltrona, è disponibile un'ampia selezione di tessuti e un'edizione iconica con rivestimento quadrettato bianco e nero e piedi verniciati basalto opaco.

Rivestimento/
Upholstery
Lady divano

—
Tessuto speciale
quadrettato bianco e nero
per edizione iconica/
Special black and white
check upholstery
for the iconic edition



ENG

Lady

Marco Zanuso,
1951/2017

The armchair is flanked by a two-seater sofa with the same production features as the armchair: seat, backrests and sides are manufactured separately with different padding densities depending

on the support required by the pressure exerted by the body. As for the armchair, a wide range of fabric upholsteries and an iconic edition with black and white check upholstery and feet painted in matt basalt are available.

03. Ico Ora-Itto 2016

ITA

Un oggetto dal sapore storico e tradizionale, rappresentativo dei valori di Cassina: una sapiente combinazione fra lavorazione di alta ebanisteria e innovazione tecnologica. La sedia, il cui progetto si è sviluppato e perfezionato con il designer grazie ad un lavoro lungo ed approfondito, è la sostanza del concetto MedaMade, che racchiude in sé la sostanza dell'artigianalità, del saper fare. Apparentemente molto semplice e lineare, questa sedia è l'espressione dell'artigianalità che si apprezza nei dettagli costruttivi della struttura, fine lavoro di ebanisteria, e nei dettagli delle cuciture che esaltano il lavoro di tappezzeria. Oltre alle caratteristiche di pregio costruttivo, la sedia offre un livello di comfort tale da renderla adatta sia agli ambienti domestici che a quelli destinati al contract.

Finiture sedia/
Chair finishes
Ico

a

Frassino tinto rosso/
Red stained ashwood
Pelle naturale/Natural
leather 13Z307



b

Frassino naturale/
Natural ashwood
Pelle naturale/ Natural
leather 13Z300



c

Frassino tinto nero/
Black stained ashwood
Pelle naturale/ Natural
leather 13Z305



ENG

03. Ico Ora-Itto 2016

An object with a historical and traditional feel, emblematic of Cassina values: a masterful combination of fine wood craftsmanship and technological innovation. The chair, whose design was developed and perfected following extended, in-depth work with the designer, is the substance of the MedaMade concept, which encapsulates the essence

of craftsmanship and of savoir faire. On the face of it very simple and linear, this chair is the expression of workmanship, seen in the construction details of the frame, the fine carpentry and in the stitching details which enhance the upholstery. In addition to its fine construction, the chair offers a comfort level that makes it suitable both for domestic settings and contract use.



mod. 202

8

36

Piero Lissoni
2014

Rivestimento divano/
Sofa upholstery
8



p 37
Pelle naturale/
Natural leather
ZZ 13Z361

ITA

Un divano dalle proporzioni equilibrate ed un elevato livello di comfort, 8 racchiude in sé il tratto di Piero Lissoni, il designer contemporaneo, che per Cassina, ha disegnato divani di successo. Il design minimale e sobrio di 8 è arricchito dalla lavorazione dettagliata del rivestimento dei cuscini indipendenti dei braccioli che si incastrano perfettamente nella struttura. Le pieghe realizzate ad arte e le cuciture invisibili valorizzano ancora di più la silhouette del pezzo. Questo divano modulare, disponibile sia in piuma che in ovatta di poliestere, si impone con la sua ampia scelta di configurazioni, con l'eleganza impeccabile e l'elevata cura sartoriale del rivestimento, fattori che evidenziano la capacità artigianale della produzione Cassina.

ENG

A very comfortable sofa of balanced proportions, 8 encapsulates the style of Piero Lissoni, a contemporary designer who has designed best-selling sofas for Cassina. The minimalist and sober design of 8

is enriched by the detailed upholstery of the cushions, separate from the armrests, which slot perfectly into the frame. The clever folds and invisible stitching further enhance the silhouette of the piece. This modular sofa,

available in both goose down and polyester wadding, offers a wide range of possible layouts, with the impeccable elegance and highly tailored detail of the upholstery, highlighting the skilled workmanship of Cassina.





01

02





Charlotte
Perriand
1903–1999

ITA

Fa parte a pieno titolo di quell'avanguardia culturale che fin dai primi decenni del ventesimo secolo ha promosso un profondo rinnovamento dei valori estetici. La collaborazione decennale con Le Corbusier e Pierre Jeanneret e l'esperienza giapponese rappresentano momenti di effervescenza creativa nella vita dell'artista. Durante il suo soggiorno in estremo oriente ('40-'46), può rivelarsi appieno il suo talento d'artista, attraverso una reinterpretazione della realtà dell'abitare che mette in risonanza tradizione e modernità. Il dato che caratterizza la personalità di Charlotte Perriand è un'onesta fedeltà ai principi di un razionalismo umano e innovatore, che ha saputo mantenere intatto nelle sue opere, di cui si è occupata con passione, anche in prospettiva della loro riedizione nella serie "Cassina I Maestri".

ENG

Charlotte Perriand holds full membership of that avant-garde cultural movement which, from the first decades of the twentieth century, brought about a profound change in aesthetic values. The ten-year long collaboration with Le Corbusier and Pierre Jeanneret, and her Japanese experience, represent periods of intense creative effervescence in the life of the artist. During her long stay in the Far East ('40-'46), she reveals her artistic talent to the full, through a reinterpretation of the reality of life to echo both tradition and modernity. The distinguishing factor of Charlotte Perriand's personality is a sincere loyalty to the principles of humane and innovative rationalism, preserved intact in her projects, on which she worked with such passion, also in readiness for their revival in the "Cassina I Maestri" collection.



1

1. Charlotte Perriand alla mostra "Proposition d'une synthèse des Arts", Tokyo, 1955/Charlotte Perriand at the "Proposition d'une synthèse des Arts" exhibition, Tokyo, 1955. 2. Charlotte Perriand con alcuni artigiani giapponesi, 1940/Charlotte Perriand with Japanese craftsmen, 1940.



2

01. Refolo 1953/2004 Collezione "Cassina iMaestri"

ITA

Un piano costituito da una grata di diciannove listelli disposti in parallelo, proposto nella finitura rovere naturale o tinto scuro, posto ad un'altezza contenuta per un uso polivalente: utilizzabile come tavolino, come panca o imbottito con la semplice aggiunta di cuscini (bracciolo, sedile e set di cuscini seduta e schienale), che vengono aggregati alla struttura e resi solidali con essa grazie ad un semplice sistema di fissaggio. Charlotte Perriand ha creato questo sistema modulare nel 1953 a Tokyo, per suo uso personale.

ENG

This surface consists of nineteen short slats arranged parallel, available in a natural oak or dark dyed finish, for a range of different uses: as a table, as a bench or padded unit by simply adding cushions (armrest, seat and set of seat

and backrest cushions), which can be added to the structure and fixed in place using a simple fastening system. Charlotte Perriand created this modular system in 1953 in Tokyo, for her own use.

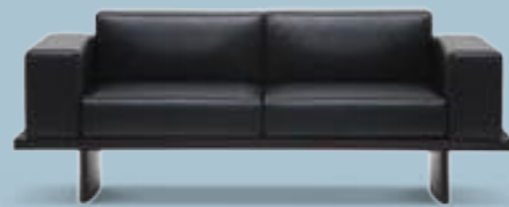

Finitura divano/
Sofa finishes
Refolo



—
Rovere tinto nero/Oak
stained black;
Pelle/Leather
Extra 13Y253

©ADP / ADGP



02. Nuage

Charlotte Perriand 1952–1956/2012

Collezione “Cassina iMaestri”

ITA

Modularità all'avanguardia: Nuage, una famiglia di librerie e contenitori firmati Charlotte Perriand per Cassina. Linguaggio chiave del design moderno, la modularità, nella visione di Charlotte Perriand, non è mai rigida o asettica, ma unisce sempre funzionalità ed estetica incontrando i bisogni del fruitore nella loro interezza.

Le composizioni del modello spaziano dalle credenze, ai contenitori, dalle librerie a muro con appoggio a terra o appese secondo schemi simmetrici o asimmetrici, alle librerie autoportanti da collocare a centro stanza, realizzate in rovere naturale o rovere tinto nero. I moduli possono avere ante a chiusura dei vani giorno, in alluminio anodizzato o colorate in un'ampia gamma di tonalità a creare un'alternanza fra pieni e vuoti.

ENG

02. Nuage Charlotte Perriand 1952–1956/2012 Collezione “Cassina iMaestri”

Cutting-edge modularity: Nuage, a family of bookcases and storage units designed by Charlotte Perriand for Cassina. Charlotte Perriand never sees modularity, the key to modern design, as rigid or aseptic. For her it always combines functionality and aesthetics, managing to completely satisfy user requirements. The compositions for this model range from sideboards, to storage

units, freestanding and wall-mounted bookcases, fixed symmetrically or asymmetrically, to self-supporting bookcases for using in the middle of rooms, in natural oak or black stained oak. The modules can be fitted with doors to close the open compartments, in anodised aluminium or in a wide range of colours, to create alternating hollows and solids.





03

03.9
Piero Lissoni 2014

ITA

Una serie di tavolini tondi, nata nel 2014 dal sapiente disegno di Piero Lissoni. I tavolini vengono proposti in versione alta o bassa, con differenti misure di piano che prevedono anche due misure per un tavolo da pranzo di dimensioni contenute. I tavolini 9 si collocano, come complementi discreti ed eleganti, in molteplici situazioni di arredo, grazie all'ampia gamma di materiali in perfetta sintonia con le finiture della collezione Cassina: legno massello di frassino tinto nero o noce canaletto, tre tipologie di marmi, bianco Carrara, nero Marquìña o grigio carnico per le basi e per i piani, oppure le versioni con le basi nelle tre tipologie di marmi con piani in vetro in diverse colorazioni. I tavolini sono disponibili con stelo in antracite o marrone castano opaco.

Finiture tavolini/
Finishes coffee tables
9

a

Base marmo nero Marquìña; piano vetro rosso mattone/Black Marquìña marble base; brick red glass top



b

Base e piano marmo nero Marquìña/ Base and top black Marquìña marble



c

Base e piano marmo Carrara bianco/ Base and top white Carrara marble



ENG

03.9
Piero Lissoni 2014

A series of small round tables, created in 2014 masterfully designed by Piero Lissoni. The tables come in a high or low version, with different sized tops, which also include two sizes for a small dining table. The 9 tables adapt, like understated and elegant accessories, to a range of furnishing situations, thanks to the wide assortment of materials in perfect harmony with the finishes of the

Cassina collection: solid black stained ashwood or American walnut, three types of marble, Carrara white, Marquìña black or Carnico grey for the bases and for the tops, or versions with bases in the three types of marble with glass tops in different colours. The coffee tables come with support in anthracite or mat chestnut brown colours.







Pelle naturale/
Natural leather ZZ 13Z361

04 LC4,
Le Corbusier, Pierre Jeanneret, Charlotte Perriand 1928/196559



Poggiatesta opzionale
in piuma/Optional feather
headrest

202 P1 larghezza 75 cm/
width 29.5"
202 P2 larghezza 90 cm/
width 35.4"

Le Corbusier, P. Jeanneret, C. Perriand

1927–1937

52



ITA

È nel 1922 che Le Corbusier apre il suo studio di architettura in rue de Sèvres, collaborando con il cugino, Pierre Jeanneret. L'intesa profonda fra i due, li porta a condurre insieme numerose ricerche, progetti e realizzazioni. Nell'ottobre 1927, decidono di avvalersi del contributo di una giovane architetta Charlotte Perriand, che all'epoca gode già di una certa notorietà. La loro collaborazione, che durerà sino al 1937, si rivelerà estremamente fruttuosa, soprattutto per quanto riguarda la creazione di mobili. Il sodalizio fra i tre autori favorirà la produzione di oggetti di una qualità artistica e culturale eccezionale con risultati oltremodo validi sul piano della loro attività professionale. È proprio con Charlotte Perriand che i due architetti affrontano all'unisono la questione de "l'équipement de la maison". La loro collaborazione sfocerà nella realizzazione di progetti innovativi, che si tradurranno in veri successi sul piano imprenditoriale.

ENG

In 1922, Le Corbusier began working in the new rue de Sèvres atelier with his cousin Pierre Jeanneret with whom he shared research projects and design criteria in a profound professional relationship. In October 1927, the pair decided to draw on the contribution of a young architect who had already begun to establish a reputation on the architectural scene of the time: Charlotte Perriand. Their collaboration lasted through to 1937 and was extremely fruitful, especially in the field of furniture design. The partnership was highly significant, both in terms of the cultural weight of their achievements and their professional successes. It was together with Charlotte Perriand that the pair tackled the innovative project for "l'équipement de la maison". The resulting designs were of great intellectual value and considerable commercial success.



1



2

1. Charlotte Perriand, Le Corbusier, Pierre Jeanneret, 1933. 2. Le Corbusier e Charlotte Perriand allo studio- appartamento di Place Saint Sulpice, Parigi, 1928, ph P. Jeanneret/ Le Corbusier and Charlotte Perriand at the studio-apartment, Place Saint Sulpice, Paris, 1928. ph P. Jeanneret. 3. Charlotte Perriand sdraiata sulla chaise longue à réglage continu, Salon d'Automne 1929/Charlotte Perriand on the chaise longue à réglage continu, Salon d'Automne 1929.

©ADP / ADGP

04. LC4 1928/1965 Collezione "Cassina iMaestri"

ITA

Disegnata nel 1928 e resa celebre dal 1965 da Cassina, LC4 è la chaise longue per antonomasia: la forma del relax, nata dalla volontà dei tre progettisti di mettere l'uomo al centro dell'attenzione, grazie alla corrispondenza fra forma e funzione del riposo, in equilibrio perfetto fra purezza geometrica e corporeità. La stabilità della culla – per qualsiasi angolo di inclinazione – è assicurata dall'attrito con tubi di gomma che rivestono i traversi del piedistallo.

ENG

Designed in 1928 and made famous by Cassina in 1965, the LC4 is the quintessential chaise longue: the relaxing shape, the outcome of the desire of the three designers to focus on the human user, with perfect correspondence

between function and form, and equilibrium between geometric purity and ergonomics. The stability of the frame – in whatever angle of inclination – is guaranteed by the friction with rubber tubes covering the cross bars of the base.



3



a



b



c



d

Rivestimenti chaise longue/
Chaise longue upholsteries
LC4

p. 54

Pelle/Leather
LCX 13Y414



a

Pelle con pelo 13Z229/
Hairyskin 13Z229



b

Pelle con pelo 13Z226/
Hairyskin 13Z226



c

Tessuto autoportante écru/
Special beige canvas



d

Pelle/Leather
LCX 13Y417



e

LC4 Pampas.
Limited Edition



e



05



Franco Albini

1905—1977

ITA

È una delle figure principali dello sviluppo del pensiero razionalista nell'ambito della produzione architettonica, dell'arredamento, dell'industrial design e dell'allestimento museale. Si laurea in Architettura al Politecnico di Milano nel 1929, collaborando successivamente con lo studio di Ponti e Lancia Fondamentale. È la collaborazione con la redazione della rivista Casabella, che sancisce la sua conversione al razionalismo di cui diventa portavoce. In tutta la sua produzione, dagli interni alle opere di industrial design, Albini garantisce sempre la presenza di coerenza logica, alta purezza espressiva e ampia moralità di misura etica e storica.

ENG

He was a major figure in the Rationalist Movement, excelling in architectural, furniture, industrial and museum design. After receiving a degree in architecture from the Politecnico di Milano in 1929, he worked with the Ponti and Lancia design studios. His work for the magazine Casabella played a key part in his development, marking his conversion to the Rationalist Movement and his becoming its spokesman. In all his work, from home furnishings to industrial and museum design projects, Franco Albini always instilled a logical consistency, an extreme purity of expression and exceptional ethical and historical integrity.



1



2



3

1. Scalata del Cervino ph. G.Pirovano, anni '50/Climbing the Matterhorn ph. G.Pirovano, 50s.
2. Franco Albini e Walter Gropius.Mostra Bauhaus, Galleria d'arte Moderna, Roma, 1961/ Franco Albini and Walter Gropius. Bauhaus exhibition, Galleria d'arte Moderna, Roma, 1961.
3. Copertina di Domus, luglio 1941 con la libreria Veliero nel soggiorno dell'appartamento dell'architetto a Milano/Cover of Domus, July 1941, with the Veliero bookcase in the living room of the architect's home in Milan.



05. Veliero 1940/2011

Collezione "Cassina iMaestri"

ITA

La libreria "Veliero", richiama nella forma e nella struttura gli stralli di un'imbarcazione a vela. Due aste in legno di frassino su cui si trovano sospesi, attraverso un sistema di tiranti in acciaio, i ripiani in vetro stratificato. Nel 1940 una sfida costruttiva per lo stesso Franco Albini, che lo aveva realizzato in un unico esemplare espressamente per la sua casa. Nel 2011 una sfida di Cassina, che dà vita a questo modello risolvendo gli aspetti strutturali con una riedizione, che mantiene inalterati i valori di leggerezza e trasparenza del modello originale.

ENG

The "Veliero" bookcase recalls the stays of a sailing boat in its shape and structure. Two ash wood pillars on which shelves in stratified glass are suspended using a system of steel rods. In 1940, it was a challenge for Franco Albini himself, who

made just one model expressly for his own home. In 2011, it was a challenge for Cassina, which has revived this model by solving the structural aspects with a re-issue that keeps the original model's lightness and transparency intact.

Finitura libreria/
Bookcase finish
Veliero



p. 56

Frassino
naturale/
Natural
ashwood

mod. 206

58

8

Cube

Piero Lissoni
2017

Rivestimento divano/
Sofa upholstery
8 Cube



p 59
Pelle naturale/
Natural leather
ZZ 13Z364

ITA

8 cube rappresenta l'evoluzione dell'iconico divano 8, di cui rivisita lo stile sobrio e minimale offrendo una collezione dalle linee più morbide e contenute. La sua costruzione avanzata accresce i valori di comfort e leggerezza introducendo soffici imbottiture in dacron sostenute da eleganti slitte in fusione di alluminio. L'eliminazione delle strutture a pannello laterale e posteriore consente di creare nuove proporzioni che semplificano il sistema originale mantenendo lo stesso impatto estetico e funzionale. L'allineamento rigoroso delle cuscinate, favorito dalla lavorazione sartoriale dei rivestimenti in pelle o tessuto, mette in risalto la qualità artigianale del design Cassina. La collezione è composta da elementi modulari, utilizzabili singolarmente o combinabili a piacimento.

ENG

An evolution of the iconic 8 sofa, 8 cube collection revisits and softens up the sober and minimal style of the original. Otto Cube is extra comfortable thanks to its state-of-the-art construction, with light-weight Dacron filling for the cushions, all

underpinned by the elegant cast aluminium sleds. By dispensing with the side and rear panels, the overall proportions change, the original design is simplified while maintaining the same impactful looks and functionalities. The attractive line-up of the

cushions, created thanks to the sartorial precision of the leather or fabric covers, highlights the crafts excellence. The 8 Cube collection consists of modular units that work equally well alone as in a composition.





Rivestimento divano/
Sofa upholstery
8 Cube

Pelle naturale/
Natural leather ZZ 13Z364

Champ
13F358



mod. 675

62

Mara— lunga

Vico Magistretti
1973

Rivestimento divano/
Sofa upholstery
Maralunga



p 63

Everest 1-Pilot
13O118

ITA

Maralunga è un divano simbolo nella collezione de iContemporanei di Cassina, opera dell'architetto e industrial designer Vico Magistretti. Vincitore del Compasso d'Oro nel 1979, Maralunga è la materializzazione dell'idea stessa di comfort, grazie alla variazione del poggiatesta per ottenere una versione a schienale alto o basso ottenuta con l'inserimento di una semplice catena da bicicletta nello schiumato dello schienale. Il modello si declina in poltrona, divani a due o a tre posti in diverse larghezze e pouf. In occasione dei suoi 40 anni, Cassina ha presentato una rinnovata interpretazione con rivestimento in tessuto o pelle, con una caratteristica cucitura lungo il profilo perimetrale, per renderlo ancora più moderno e contemporaneo, anche in versione sfoderabile per il tessuto.

ENG

Maralunga is an emblematic sofa of the iContemporanei collection by Cassina, the work of architect and industrial designer Vico Magistretti. Winner of the Compasso d'Oro in 1979, Maralunga is the embodiment of the very idea of

comfort, with an adjustable headrest for a high or low backrest version obtained by inserting a simple bicycle chain inside the foam of the backrest. The model comes as an armchair, two- or three-seater sofas in different widths, and pouf.

To mark its 40th anniversary, Cassina presents a new interpretation with fabric or leather upholstery and distinctive profile stitching, to make it even more modern and contemporary, also available with removable cover.





01



01. Casiers Standard

Le Corbusier, Pierre Jeanneret, Charlotte Perriand
1925–1978/2017

Collezione “Cassina iMaestri”

ITA

Gli storici contenitori, in collezione dal 1978, vengono rilanciati in veste rinnovata, tesa ad esaltare le caratteristiche che rendono questi mobili dal design unico e senza tempo, versatili, funzionali e estremamente adatti all'organizzazione dello spazio.

I contenitori sono proposti in 18 composizioni fisse, in versione da due o da tre moduli, in tre differenti tipologie: con vani a giorno, con due ante battenti, con anta a ribalta inferiore.

L'ampia gamma di coloriture - contemplate per le basi, le parti esterne e interne dei moduli e le ante - consente interessanti ed eleganti avvicendamenti.

a

Composizione 020 B3/
020 B3 Configuration

ENG

01. Casiers Standard
Le Corbusier, Pierre Jeanneret, Charlotte Perriand 1925–1978/2017
Collezione “Cassina iMaestri”

These historic storage units, in the collection since 1978, are relaunched with a new look emphasising the features that make this unique furniture with its timeless design versatile, functional and perfect for the organisation of space. The units come in 18 fixed compositions, in two- and three-module

versions and in three different types: with open compartments, with two hinged doors or with lover folding door. The wide range of colours—for the bases, external and internal parts of the modules and the doors—makes interesting, elegant solutions possible.

a

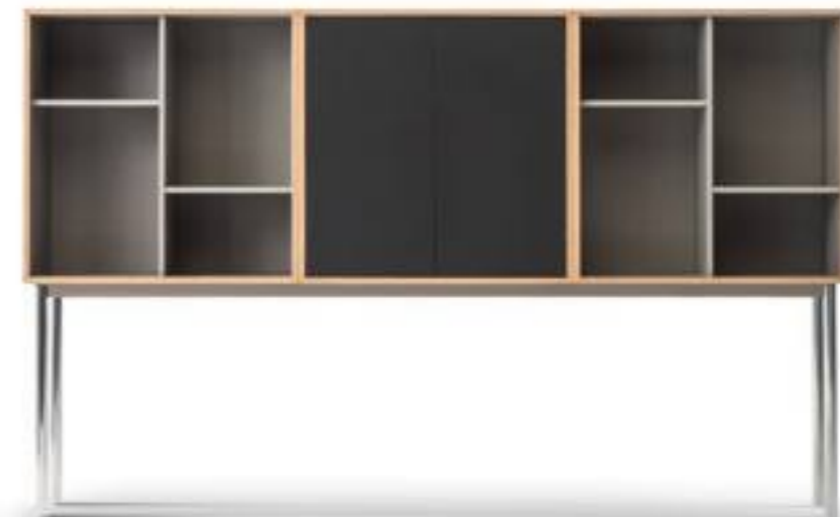



Vico Magistretti

1920–2006

ITA

Nasce nel 1920 e si laurea in architettura a Milano nel 1945 e dove svolge la sua attività professionale occupandosi di architettura, urbanistica, industrial design. Il primo riconoscimento per il suo lavoro lo ottiene nel 1948, vincendo il Gran Premio della VIII Triennale. Dopo questo almeno quaranta altri premi e riconoscimenti per i vari settori di attività premiano il lavoro di Vico Magistretti in vari paesi. I mobili, le lampade e gli oggetti da lui disegnati si trovano in tutto il mondo e i più importanti musei di design gli hanno dedicato mostre e accolto le sue opere nelle loro collezioni permanenti. Per Cassina disegna dal 1960 e ha firmato numerosi prodotti, tra i quali il divano Maralunga (1973) e la libreria Nuvola Rossa (1977) che sono tuttora indiscutibilmente dei best-seller internazionali.



1

ENG

In 1920 Magistretti was born in Milan, the city in which he graduated in architecture in 1945, and where his professional career has spun its story ever since, chiefly in the fields of architecture, town planning and industrial design. The first recognition of his work came in 1948, when he won the Gran Premio at the 8th Triennale. After that came almost forty prizes and awards in recognition of Magistretti's work in various sectors in different countries. Furniture, lamps and other objects that he designed may be found all over the world and the most important design museums have given exhibitions in his honour and kept examples of his work in their permanent collections. He started designing for Cassina in 1960, and from that date on his signature is to be found on very many products. We recall in particular the Maralunga sofa (1973) and the Nuvola Rossa (1977) bookcase, which are still indisputable international best-sellers.

ITA

“Con Maralunga – ho inteso progettare un oggetto rappresentativo di tutta un'architettura d'interni di sapore familiare. Un posto caldo, confortevole, raccolto, dove sentirsi a proprio agio e ritrovare l'atmosfera delle vecchie, comode, protettive poltrone di lettura poste vicino al fuoco di un camino o al raggio di luce di una finestra. Due posizioni, due possibilità d'uso, due occasioni per crearsi il proprio spazio all'interno di una stanza.”

Vico Magistretti

ENG

“With Maralunga my aim was to exemplify the hearthside aspect of interior design: a warm, cosy and restful area where you can relax and feel at ease and discovering a new protective warmth of those comfy armchairs of old, lit by the glow of the evening

fore or by the sun streaming in through the window. Two positions, two opportunities for personalizing your living area”.

Vico Magistretti



2

1. L'architetto Vico Magistretti seduto sulla poltrona Maralunga/ The architect Vico Magistretti sitting on the Maralunga armchair. 2. Poltrona Maralunga e pouf/ Maralunga armchair and ottoman.

Maria Milas—M. Carriè





02. Rio
Charlotte Perriand 1962/2015
Collezione "Cassina iMaestri"

ITA

Questo tavolino fu progettato in due diverse dimensioni da Charlotte Perriand. Cassina, perseguendo con spirito autentico la riedizione di modelli originali, ha ricostruito anche in questo caso il primo progetto del 1962, disegnato per l'abitazione di Jacques Martin a Rio. Il tavolino, di forma tonda, è costituito da sei spicchi accostati, non allineati e di diverso raggio, in paglia di Vienna o marmo bianco di Carrara con bordi esterni in rovere naturale, oppure in marmo Marquìña nero con bordi esterni in rovere tinto nero.

ENG

02. Rio
Charlotte Perriand 1962/2015
Collezione "Cassina iMaestri"

Charlotte Perriand designed this table in two different sizes. Cassina, in its authentic approach to the reissue of the original models, has recreated the original design of 1962, conceived for Jacques Martin's home in Rio.

The round table is made up of six wedge sections, misaligned and of different radiuses, in rattan or white Carrara marble with outer edges in natural oak, or in black Marquìña marble with outer edges in black stained oak.





03

Rivestimento divano/
Sofa upholstery
Maralunga



Pelle/Leather
Extra 13Y276

03 Tavolini/Coffee tables LC10-P,
Le Corbusier, P.Jeaneret, C. Perriand 1928/1985 — p 74

03. LC10 — P

Le Corbusier, Pierre Jeanneret, Charlotte Perriand
1928/1985

Collezione "Cassina iMaestri"

ITA

Una serie di tavoli e tavoli bassi, di forma quadrata e rettangolare, con gambe in acciaio cromato e struttura verniciata proposta nei diversi colori della palette originale di Le Corbusier. Il tavolo originale, disegnato dai tre maestri dell'architettura, fu presentato al Salon d'Automne di Parigi nel 1929, nell'allestimento per "l'Équipement Intérieur d'une Habitation" e aveva funzioni di scrittoio. Charlotte Perriand rivisitò il progetto originario nel 1984, consentendo soluzioni in grado di offrire varianti rispondenti alle necessità d'uso di oggi. Cassina lo rieditò nel 1985.

Finiture tavolini/
Coffee tables finishes
LC10—P

a
Struttura verniciata
marrone/Brown
lacquered frame

b
Struttura verniciata
grigio/Grey
lacquered frame



a



b

ENG

03. LC10 — P Le Corbusier, Pierre Jeanneret, Charlotte Perriand 1928/1985 Collezione "Cassina iMaestri"

A series of tables and low tables, square and rectangular, with legs in chrome steel and painted frame available in the different colours of Le Corbusier's original palette. The original table, designed by three masters of architecture, was presented as a desk

in "l'Équipement Intérieur d'une Habitation" at the Salon d'Automne in Paris in 1929. Charlotte Perriand revisited the original design in 1984, producing solutions capable of offering different versions that meet today's practical requirements. Cassina reissued it in 1985.

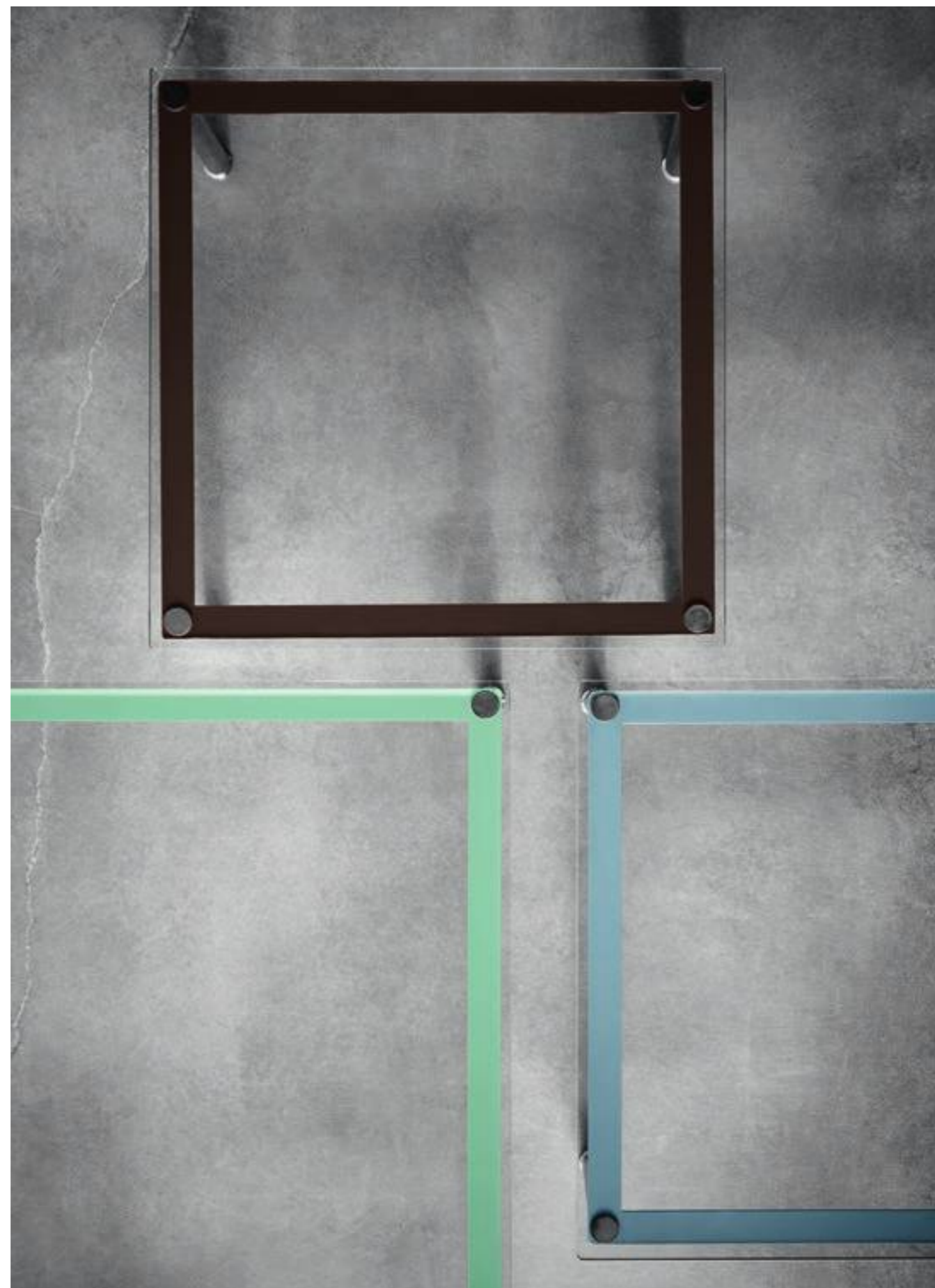



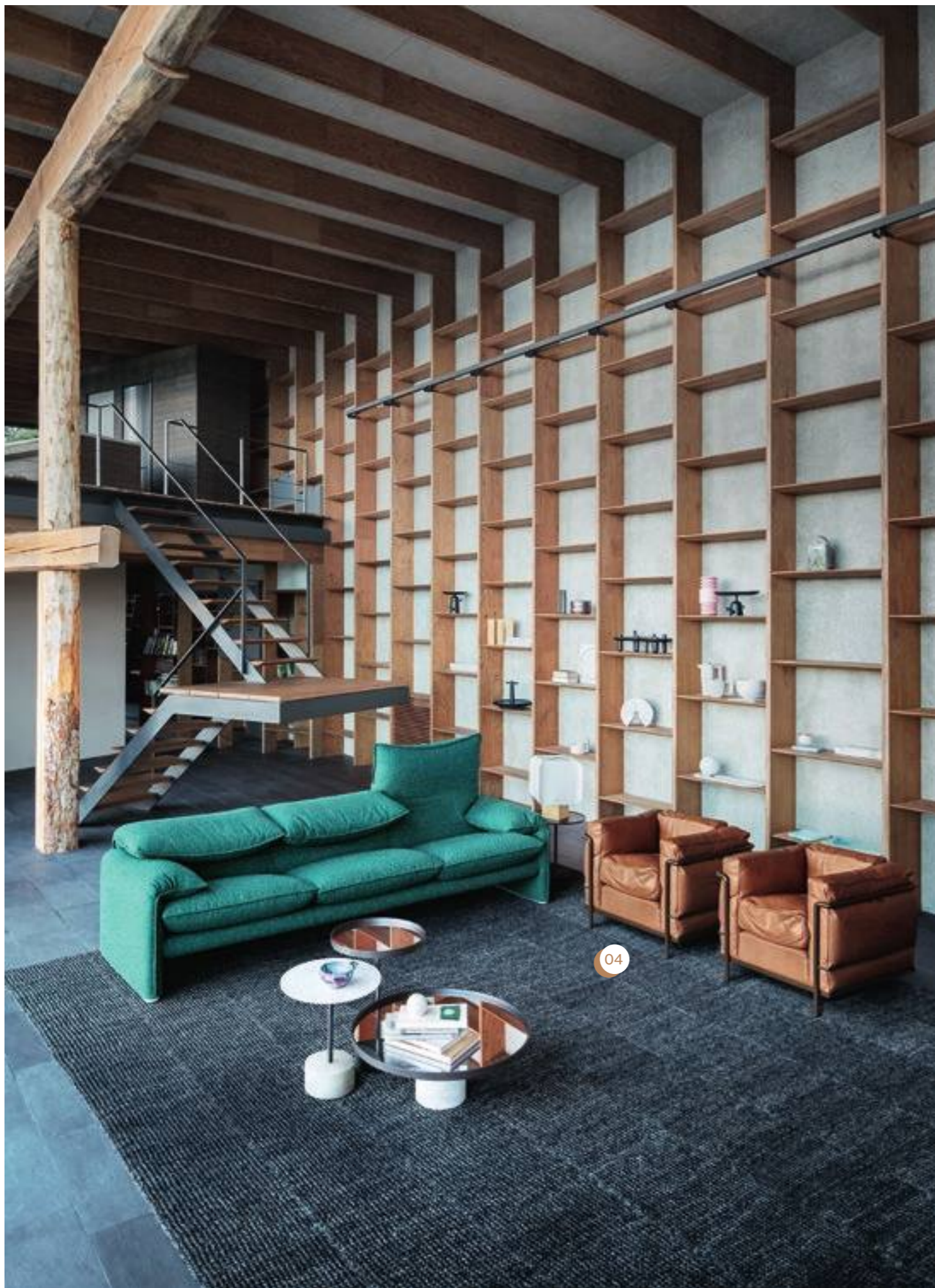

04

04. LC2

Le Corbusier, P. Jeanneret, C. Perriand 1928/1965
Collezione "Cassina iMaestri"

ITA

Poltrona, divani a due e a tre posti e pouf con strutture in acciaio cromato lucido o verniciato nella palette di colori LC. Rivestimenti dei cuscini indipendenti in tessuto o pelle. LC2 è un modello senza tempo, che ha fatto la storia del design. La poltrona, disegnata nel 1928 ed esposta al Salon d'Automne a Parigi nel 1929, è l'archetipo della poltrona nella nuova e moderna concezione degli arredi intesi come "attrezzature domestiche", rieditata da Cassina e prodotta in esclusiva dal 1965. L'indipendenza fra la struttura metallica e i cuscini esprime logica del razionalismo: la separazione tra parti secondo una logica di produzione industriale.

Finiture poltrone/
Armchairs finishes
LC2

a

Struttura verniciata
marrone; pelle LCX
13Y416/Brown enamel
frame; LCX leather 13Y416



a

b

Struttura verniciata
azzurra; Everest 1-Pamir
13O090/Light blue
enamel frame;
Everest 1-Pamir 13O090



b

c

Struttura verniciata fango;
Panorama 1-Waterborn
13F811/Mud enamel frame;
Panorama 1-Waterborn
13F811



c

d

Struttura cromata;
pelle LCX 13Y415/
Chromed frame;
LCX leather 13Y415



d

ENG

04. LC2
Le Corbusier, P. Jeanneret, C. Perriand
1928/1965 Collezione "Cassina iMaestri"

Armchair, two- and three-seater sofas and ottoman with polished chrome or painted steel frame in the LC colour palette. Separate cushions upholstered in fabric or leather. LC2 is a timeless model, which has made design history. Designed in 1928 and exhibited at the Salon d'Automne in Paris

in 1929, it is the archetypal armchair in the new and modern conception of furnishings understood as "domestic equipment", re-issued by Cassina and produced exclusively since 1965. The separation of the metal frame and the cushions expresses a rationalist approach to industrial production.

mod. 675

80

Maralunga 40 Maxi

Vico Magistretti
1973/2018

Rivestimento divano/
Sofa upholstery
Maralunga 40 Maxi



p 81
Pelle Naturale/
Natural Leather
ZZ 13Z360

Novità/News 2018

ITA

A 45 anni dal lancio del primo modello, e dopo l'introduzione di Maralunga 40 e della variante 40S in tessuto sfoderabile, la proposta Maralunga si amplia nuovamente aggiornando le proporzioni e l'estetica del divano per una maggiore sensazione di comfort ed eleganza. Maralunga Maxi è una versione più contemporanea del leggendario best-seller di Cassina, che conserva il brevetto tecnologico della variazione dello schienale ottenuta mediante l'integrazione di una semplice catena di biciletta. Disponibile unicamente con la raffinata cucitura perimetrale, il modello Maxi presenta una nuova misura di poltrona di 122 cm, un divano due posti da 214 cm e un divano 3 posti da 310 cm. La profondità è aumentata a 105 cm per offrire maggiore comodità e accoglienza, mentre per tutti i modelli è disponibile un cuscino poggiatesta in piuma in una nuova dimensione che incrementa l'effetto ergonomico.

ENG

Forty-five years after the launch of the original, and following on from the Maralunga 40 and its variant, the 40S with removable fabric covers, the Maralunga sofa takes the stage once more, its proportions updated, and its look restyled, becoming even more elegant and comfortable than before. Maralunga 40

Maxi is a contemporary take on this legendary best-seller by Cassina, which holds the technological patent for the device – a bicycle chain – that adjusts the angle of the back-rest. Supplied with the refined edge-stitching finish as standard, the Maralunga 40 Maxi armchair debuts a new size for its type: 122

cm. Meanwhile, the two-seater sofa comes in at 214 cm, with the three-seater measuring 310 cm. The depth has increased to 105 cm, to make for a more inviting and comfortable sitting position; all the models can be fitted with a feather-filled seat cushion in a new size to enhance ergonomic correctness.





Rivestimento divano/
Sofa upholstery
Maralunga 40 Maxi

Pelle naturale/
Natural leather ZZ 132360

01 Sedia/Chair Back-Wing,
Patricia Urquiola 2018 — p 87

02 Tavolo/Table Mexique,
Charlotte Perriand 2018 — p 88



Pelle naturale/
Natural leather ZZ 13Z360

Rivestimento divano/
Sofa upholstery
Maralunga 40 Maxi





01. Back-Wing Patricia Urquiola, 2018

ITA

La sapienza costruttiva del Meda Made si traduce in una nuova sedia che supera gli stereotipi classici innescando nuovi linguaggi sperimentali di forte identità. La struttura del cavalletto, interamente realizzata in legno massello di frassino, è composta da gambe e traversi con grandi sezioni basiche che esprimono solidità ed energia. L'innovazione formale nasce dal contrasto tra lo spessore marcato della struttura e le superfici esili e sottili del rivestimento, piegato come un foglio per conferire all'oggetto un movimento sorprendente.

L'angolazione ergonomica dello schienale e l'imbottitura invisibile accrescono la sensazione di comfort creando un effetto avvolgente in cui la piega superiore funge anche da appoggio per le braccia. L'estetica è esaltata dalle finiture eleganti, dall'assenza di cuciture a vista e dal cordoncino rivestito in pelle che delimita il profilo perimetrale disegnando con precisione la forma della sedia.

Finiture sedie/
Chairs finishes
Back-Wing

a

Frassino tinto nero,
pelle grafite 13X606/
Ashwood stained black,
leather grafite 13X606



Novità/News 2018

b

Frassino tinto rovere,
pelle naturale 13Z200/
Ashwood stained oak,
natural leather 13Z200



a



b

ENG

01. Back-Wing Patricia Urquiola, 2018

The furniture-making skills known as MedaMade, a trade mark patented by Cassina, is made manifest in a new chair that, leaving classical stereotypes behind, sparks off powerful new idioms. The frame, in solid ashwood, consists of basic big, bold legs and cross-pieces with a solid and energetic look. The innovative nature of this chair springs from the contrast between the strong lines of the frame and the slender, understated planes,

draped like a sheet of paper, conveying a striking sense of movement. The ergonomically-correct angle of the back and the invisible upholstery augment the comfortable look of the chair, creating a wrap-around feel where the turned-down top of the back becomes the arm-rest. The overall look is enhanced thanks to the elegant finishing touches, no stitching in sight, and a delicate leather-trim delineating the edges of the back and seat.

02. Mexique

Charlotte Perriand, 1952–56/2014–18

Collezione “Cassina iMaestri”

ITA

Incluso tra i tavoli en forme libre sviluppati tra il 1938 e il 1939, il progetto finale fu concepito nel 1952 per le camere degli studenti della Maison du Mexique alla Cité Universitaire Internationale di Parigi. La struttura concepita per occupare il minor spazio possibile prevedeva la possibilità di affiancare tra loro più pezzi per creare composizioni di forma più ampia e regolare. Nel 1952 l'autrice sostituì le gambe in legno con gambe a sezione triangolare in lamiera piegata. Nel 1956 venne realizzata una versione bassa per la Galerie Steph Simon di Parigi. Lo spessore alto del piano in legno, disponibile sia in massello che in laccato lucido o opaco, trasmette notevole bellezza, mentre i bordi svelano un profilo funzionale alla forma e alla dimensione della mano. Nel 2018 si aggiungono due nuove varianti da pranzo che consentono di ospitare 5 o 6 commensali. Sono state inoltre introdotte nuove finiture che accrescono ulteriormente la combinabilità e la funzionalità dei tavoli.

Finiture tavolo/
Table finishes
Mexique

Novità/News 2018

p 89

Gambe canna di fucile,
noce canaletto/
Gunmetal legs,
american walnut



a

Gambe canna di fucile,
piano Marron glacé/
Gunmetal legs,
top Marron glacé



b

Gambe nero opaco,
piano laccato nero opaco/
Mat black legs, mat
black laquered top



a



b

ENG

02. Mexique

Charlotte Perriand, 1952–56/2014–18
Collezione “Cassina iMaestri”

Included as one of the tables *en forme libre* created between 1938 and 1939, the final design was developed in 1952 for the students' rooms of the Maison du Mexique at the Cité Universitaire Internationale in Paris. With a frame designed to be as compact as possible, the tables could be juxtaposed to create larger, symmetrical units. In 1952, the wooden legs were replaced by triangular-section bent metal. In 1956, the low-level version was created for the Galerie Steph

Simon in Paris.

The generous depth of the wooden tabletop, available in solid wood, as well as with a gloss or matte finish, resonates with rare beauty. Meanwhile, form follows function in the edges form, reflecting the size of the human hand. In 2018, two new dining table variants of the Mexique are being launched, designed to accommodate between five and six guests. In addition, a number of new finishes enhance further the potential for these tables to work together and serve new purposes.



mod. 192—193

90

Miloe

Piero Lissoni
2012

Rivestimento divano/
Sofa upholstery
Miloe



p 91

Morandi 1
Diablo 13F760

ITA

Miloe è un paesaggio nel quale riconoscersi, uno skyline da modellare in configurazioni confortevoli; con rivestimento in tessuto o in pelle, si integra perfettamente in ogni scenario grazie ad un abaco molto duttile ed ampio: divani a due posti ed elementi imbottiti in due profondità – terminali, centrali, angolari e pouf, modulari e componibili – che si aggregano a formare molteplici composizioni.

Una serie di soffici cuscini in varie dimensioni e colori permette di dare vita a effetti grafici ed emozionali infiniti. Il divano a terra è disponibile in due diverse profondità, da conversazione o da relax, ed è studiato per offrire in ogni caso una seduta accogliente.

ENG

Miloe is a landscape you can relate to, a skyline to be modelled into comfortable combinations; with fabric or leather upholstery, it blends in perfectly with any setting thanks to wide and versatile range of elements:

two-seater sofas and padded elements in two depths – ends parts, central parts, corner elements and poufs, which can be mixed and matched to form a wide range of compositions. A series of soft cushions in different sizes and colours give

life to countless graphic and high impact effects. The floor sofa comes in two different depths, for conversation or relaxation, and is nonetheless designed to be a comfortable place to sit.







01

03

02

Rivestimento divano/
Sofa upholstery
Miloo

Everest 1
Tensing 13F437

01 Sgabelli/Stool Tabouret Méribel,
Charlotte Perriand 1953-1961-62 — p 97

02 Sgabelli/Stools LC14,
Le Corbusier 1952-59/2010 — p 98

03 Accessori/Accessories Réaction
Poétique, Jaime Hayon 2015 — p 100



01. Tabouret Berger/Méribel
Charlotte Perriand 1953–1961/2011
Collezione "Cassina iMaestri"

ITA

Lo sgabello alto (Méribel) prende il nome dallo chalet di Méribel in Francia, dove Charlotte Perriand aveva una dimora e dove negli anni ha reinterpretato l'architettura locale. Caratterizzato da tre gambe "a taglio". La versione bassa dello sgabello (Berger) si ispira agli sgabelli utilizzati dai pastori e a questo deve il suo nome. Caratterizzato da tre gambe tornite. Entrambe le versioni sono in legno massello nelle finiture rovere naturale, tinto nero e in noce canaletto naturale. L'utilizzo del massello trasferisce piacevoli morbidezze, con la continuità della venatura tra piano e bordo, la profondità delle superfici che disegnano su ogni pezzo infinite variazioni autentiche.

Finiture sgabelli/
Stool finishes
Tabouret Berger/Méribel

—
Rovere naturale/
Natural oak



—
Rovere tinto nero/
Black stained oak



—
Noce canaletto/
American walnut



ENG

01. Tabouret Berger/Méribel
Charlotte Perriand 1953–1961/2011
Collezione "Cassina iMaestri"

The high stool (Méribel) takes its name from the Méribel chalet in France, where Charlotte Perriand had a house and where she reinterpreted the local architecture over the years. Marked by three "cut-finished" legs. The low version of the stool (Berger) draws inspiration from the stools used by shepherds and hence its name. Marked by three turned legs.

Both versions come in solid wood with a natural or black stained oak and natural American walnut finish. The use of solid wood conveys a pleasant sense of softness, with continuous grain between the top and the edge, and a depth of surfaces that traces infinite authentic variations on each piece.





Le Corbusier

1887—1965

ITA

Charles-Edouard Jeanneret, detto Le Corbusier, è nato a La Chaux-de-Fonds, in Svizzera ed è morto in Francia, a Roquebrune-Cap-Martin, nel 1965. Nella sua attività di urbanista, architetto e designer, il suo metodo di ricerca, in un continuo processo di evoluzione, tocca a volte anche gli estremi opposti di un cospicuo linguaggio plastico. Fra le innumerevoli testimonianze: l'Unité di abitazione di Marsiglia (1946-52); la Cappella Notre-Dame du Haut a Ronchamp (1950-55); Il Convento dei Domenicani "La Tourette" a Eveux (1951-56). Lo stesso impegno si ritrova nella progettazione dei numerosi arredi, quali: i mobili dell'Equipement Intérieur de la maison progettati per il Salon d'Automne del 1929, insieme con Pierre Jeanneret e Charlotte Perriand e nei "Casiers Standard", sistema di mobili contenitori progettati per il Padiglione dell'Esprit Nouveau del 1925, in collaborazione con Pierre Jeanneret.

ENG

Charles-Edouard Jeanneret, known as Le Corbusier, was born at La Chaux-de-Fonds, in Switzerland, in 1887; he died in France, at Roquebrune-Cap-Martin in 1965. In his activities as town-planner, architect and designer, his method of research continued to develop, at times going to the opposite extremes of a rich plastic idiom. Instances of this are: Unité d'Habitation in Marseille (1946-52); the Chapel Notre-Dame du Haut at Ronchamp (1950-55); the Dominican Monastery "La Tourette" at Eveux (1951-56). Much the same commitment will be found in the design of several furnishings, such as: the furniture of the Equipement Intérieur de la maison for the Salon d'Automne in 1929 with Pierre Jeanneret and Charlotte Perriand and "Casiers Standard", system of container units designed for the Pavillon of the Esprit Nouveau, 1925 in collaboration with Pierre Jeanneret.

02. LC14 1952—1959/2010

Collezione "Cassina iMaestri"



ITA

LC14 01 Tabouret Cabanon

Disegnato nel 1952 per il Cabanon, un capanno costruito da Le Corbusier in Costa Azzurra, dove accanto a numerosi arredi fissi, gli arredi mobili sono tutti concepiti come scatole. Una seduta spartana, e al tempo stesso, raffinata grazie agli incastrati a coda di rondine che sottolineano le connessioni tra i piani in massello. Il foro oblungo su ogni faccia rende il Tabouret particolarmente maneggevole. Realizzato in massello di castagno, tinto naturale.

LC14 02 Tabouret Maison du Brésil

Progettato da Le Corbusier nel 1959 per la Maison du Brésil nella Città Universitaria di Parigi, è uno sgabello realizzato in massello di rovere tinto naturale. Sulle due facce principali, le aperture oblunghe agevolano lo spostamento dello sgabello, posizionabile sia in orizzontale che in verticale. Esclusivo il sistema di incastro a coda di rondine sugli spigoli, che valorizza la precisione e l'abilità di Cassina nella lavorazione del massello.

ENG

LC14 01 Tabouret stool Cabanon

Designed in 1952 for the Cabanon, a hut built by Le Corbusier on the French Riviera, where alongside the many fixed furnishings, the furniture was all conceived as boxes. This stool is Spartan and yet at the same time sophisticated due to its dovetail joints that highlight the connections between the solid wood surfaces. The oblong hole on each side makes Tabouret very easy to handle. Made in natural-coloured

solid chestnut wood. **LC14 02 Tabouret stool Maison du Brésil** Designed by Le Corbusier in 1959 for the Maison du Brésil at the Cité Internationale Universitaire de Paris. The oblong openings on the two main sides make it easy to move the stool, which can be positioned either horizontally or vertically. The exclusive system of dovetail joints on the corners shows off the precision and skill of Cassina in working solid wood.

Finitura sgabello/ Stool finish LC14



— Castagno/
Chestnut

LC14 Tabouret Nantes Rezé

1952—59/2018

Collezione "Cassina iMaestri"



ITA

Questo sgabello tavolino fu realizzato per le stanze dei bambini dell' Unité d'habitation di Nantes Rezé. Progettato secondo la poetica dell'objet trouvé, cara al maestro nell'ultima parte della sua esistenza, l'oggetto presenta oggi nuovi dettagli rispetto alle varianti già incluse in collezione. Sviluppato dopo il primo progetto per il Tabouret Cabanon a due dimensioni del 1952, il modello anticipa nella composizione a tre dimensioni il Tabouret du Brésil differenziandosi per la maggior semplicità dei giunti. Le altre due versioni sono caratterizzate da incastrati tra i piani a coda di rondine, mentre questo pezzo prevede un'unione dei pannelli ortogonali semplificata e minimale. Le diverse facce, in rovere laccato a poro aperto, sono caratterizzate da due colori della palette di Le Corbusier: azzurro oltremare e marrone. L'impugnatura è semplificata con un incavo rettangolare e non arrotondato.

ENG

This stool/low table was created for the children's rooms in the Unité d'Habitation in Nantes Rezé. Designed using the poetics of the objet trouvé, dear to Le Corbusier in the latter part of his life, this piece is now available with a number of added details compared to the original in the Cassina collection. Developed after the first design for the Tabouret Cabanon in 1952, whose main face measured 43cm x 43cm, this piece was a precursor to the 43cm x 33cm Tabouret du Brésil, the main difference being that its joints were less complex. The other two versions are characterised by dovetail joints while this version privileges simple right-angles. The different faces, in open-pore varnished oak, is available in two of the Corbusier palette colours: light blue and brown. The rectangular slots each side, featuring unrounded corners, are used for lifting and moving the stool.

Finitura sgabello/ Stool finish LC14 Tabouret Nantes Rezé



— Rovere laccato
marrone e azzurro/
Oak lacquered brown
and light blue



1

1. Camera dei bambini, Unité d'habitation di Nantes Rezé, 1955/
Children's room, Unité d'habitation Nantes Rezé, 1955



03. Réaction Poétique Jaime Hayon 2015

ITA

Collezione di oggetti ispirata alle opere pittoriche e scultoree del maestro dell'architettura Le Corbusier e reinterpretata dal designer Jaime Hayon. Quattro centrotavola, un vassoio e due tavolini, tutti rigorosamente realizzati in frassino massello tinto nero. Gli oggetti sono contenuti in un imballo dedicato, sono autenticati e accompagnati da libretto descrittivo.

Finitura complemento/
Complement finish
Réaction Poétique

— Frassino tinto nero/
Black stained
ashwood



Altre finiture/
Other finishings

— Frassino tinto amaranto/
Ashwood stained
amaranth



— Frassino tinto fango/
Ashwood
stained mud



— Frassino tinto petrolio/
Ashwood stained
petroleum



ENG

03. Réaction Poétique Jaime Hayon 2015

Collection of objects inspired by paintings and sculptures by the master of architecture Le Corbusier and reinterpreted by the designer Jaime Hayon. Four centrepieces, a tray and two small

tables, all strictly made in solid black stained ashwood. The objects come in special packaging, are authenticated and accompanied by a description leaflet.







Rivestimenti divano/
Sofa upholsteries
Miloe



p 104

Morandi 1
Diablo 13F760

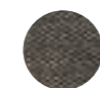

p 105

Marocco
13F754



04

Rivestimento divano/
Sofa upholstery
Miloo

Everest1
Tensing 13F437

04 Libreria/Bookcase Infinito,
Franco Albini 1956-57/2008 - p. 109



04. Infinito
 Franco Albini 1956—57/2008
 Collezione "Cassina iMaestri"

ITA

Disegnata da Franco Albini negli anni 1956/57 e prodotta da Cassina a partire dal 2008, Infinito è una libreria componibile costituita da montanti, contenitore ad ante battenti, a ribalta e mensole, proposta nelle finiture frassino naturale, frassino tinto nero o noce canaletto. Serialità industriale per ciascun componente del prodotto, che consente infinite e differenti soluzioni compositive, dalle strutture portanti ai componenti. La struttura, non necessitando di ancoraggi a parete, può offrire superficie con due facciate contrapposte contenenti i piani di appoggio per i libri ed altre soluzioni di contenimento.

ENG

04. Infinito
 Franco Albini 1956—57/2008
 Collezione "Cassina iMaestri"

Designed by Franco Albini in 1956/57 and produced by Cassina from 2008, Infinito is a modular bookcase consisting of vertical supports, storage units with swing and bottom hinged doors, and shelves, available in natural ashwood, black stained ashwood or American walnut finish. Each element of

the product was mass-produced, allowing for countless possible arrangements, from the supports to the components. The structure, which does not need to be fixed to the wall, can offer a double surface, namely a partition with two sides containing bookshelves and other storage solutions.

Finiture libreria/
 Bookcase finishes
 Infinito

p 108

Frassino tinto nero/
 Black stained ashwood



p 107

Noce canaletto/
 American walnut



Altre finiture/
 Other finishings

Frassino naturale/
 Natural ashwood



a





05. P22
Patrick Norguet 2013

ITA

"La mia intenzione era quella di progettare una poltrona di relax, rispettando le tradizioni classiche ma allo stesso tempo mescolando delle influenze moderne", questa la dichiarazione del designer francese Patrick Norguet, noto sulla scena internazionale per il suo "french touch". È nata così la poltrona P22, un'equilibrata mescolanza di design senza tempo e confort, una poltrona accogliente che spicca anche per il suo aspetto moderno. Un poggiatesta abbinato, che funge anche da pouf, permette di stendersi e rilassarsi ulteriormente. La poltrona è disponibile nella versione con o senza poggiatesta, in un'ampia gamma di rivestimenti amovibili e anche con combinazioni differenti di tessuto e pelle per le parti interne ed esterne secondo uno schema preordinato.

Finiture poltrona/
Armchair finishes
P22

a

Base noce canaletto; pelle naturale 13Z305/American walnut base; natural leather 13Z305



b

Base alluminio marrone castano opaco/Mat chestnut brown painted aluminium base; Uni.MèLange 13O616



c

Base alluminio verniciato fango/Mud lacquered aluminium base; Uni.Mèlange 13O620



p 113

Base alluminio verniciato nero/Black lacquered aluminium base; Panorama 1 Divina MB 13F286



ENG

05. P22
Patrick Norguet
2013

"I wanted to design an armchair for relaxation, in keeping with classic traditions but at the same time mixing in some modern influences," says French designer Patrick Norguet, famous on the international scene for his "french touch". And so the P22 armchair arose, a balanced combination of timeless design and comfort, an inviting armchair that stands out also

for its modern appearance. A matching footrest, which also acts as an ottoman, makes it even easier to stretch out and relax. The armchair is available in a version with or without headrest, in a wide range of removable upholstery also in different combinations of fabric and leather for the inner and outer parts according to specific patterns.



a



b



c





mod. 271

116

Mex Cube

Piero Lissoni
2007

Rivestimento divano/
Sofa upholstery
Mex Cube



p 117
Moon
13K739

ITA

La declinazione di un'idea che diventa progetto; Mex Cube si propone come un sistema caratterizzato da estrema versatilità. Molteplici varianti, che consentono altrettante combinazioni d'uso. Sistema di sedute con elementi, disponibili in due profondità combinabili tra loro, con o senza schienale e braccioli di forme e funzioni diverse, che consentono innumerevoli composizioni: ad angolo, in linea, a isola, con sedute contrapposte, con misure e proporzioni studiatissime, a tracciare gesti individuali della quotidianità, a riprodurre le forme della socialità, della conversazione in un quadro armonico di variazioni sul tema.

ENG

The interpretation of an idea becomes a design; Mex Cube sets out to be a system marked by extreme versatility. Its numerous versions allow for many practical combinations. A seating system with elements, available in two depths that can

be combined, with or without backrest and armrests in different shapes and functions, giving rise to countless possible compositions: corner, straight, island, with opposite seats, with carefully designed sizes and proportions, trace the personal

gestures of everyday living, reproducing the forms of socialisation and conversation in a harmonious set of variations on a theme.





01

Rivestimento divano/
Sofa upholstery
Mex Cube

Everest1
Kathmandu 13F455

01 Poltrona/ Armchair LC3,
Le Corbusier, P.Jeanneret, C. Perriand 1928/1965 — p 121



01. LC3

Le Corbusier, P. Jeanneret, C. Perriand 1928/1965
Collezione "Cassina iMaestri"

ITA

Quattro cuscini, privi di legami, sono contenuti in una gabbia di tubi di acciaio verniciato o cromato, che costituisce il supporto primario dell'oggetto. Poltrona con due braccioli e poltrone con bracciolo sinistro o destro, divani a due o a tre posti con struttura in acciaio cromato trivalente (CR3) oppure verniciato nella palette di colori originali di Le Corbusier. Il rivestimento dei cuscini è in tessuto oppure in pelle.

Finiture poltrona/
Armchair finishes
LC3

p 120

Struttura cromata;
pelle LCX 13Y415/
Chrome-plated frame;
leather LCX 13Y415



a

Struttura verniciata nera;
Everest 1—Nanga Parbat
13F369/Black enamel
frame; Everest 1—Nanga
Parbat 13F369



b

Struttura verniciata
grigia; pelle LCX 13Y412/
Grey enamel frame;
leather LCX 13Y412



ENG

01. LC3
Le Corbusier, P. Jeanneret, C. Perriand
1928/1965 Collezione "Cassina iMaestri"

Four unconnected
cushions, enclosed
in a painted or chrome
steel tube cage that
constitutes the primary
support system.
Armchair with two
armrests and
armchairs with
left-hand or right-hand

armrest, two- or
three-seater sofas
with frame in trivalent
chrome steel (CR3)
or painted in colours
from the original
Le Corbusier palette.
The cushions are
covered in fabric
or leather.



a



b



02

02. Torei Luca Nichetto 2012

ITA

La collezione di tavolini grafici Torei è stata progettata nel 2012 da Luca Nichetto, giovane architetto veneziano impegnato nell'industrial design, campo nel quale di è distinto grazie ad importanti collaborazioni.

Questa serie di tavolini, in continua evoluzione è stata ampliata nella già consistente proposta originale: diverse forme, tonda, quadrata, triangolare e differenti materiali, dal frassino naturale, tinto nero o rosso a tre tipologie di marmo, bianco Carrara, nero Marquiña o grigio Carnico.

La base, disponibile nella finitura verniciata nero opaco, viene ora proposta anche nella finitura verniciata marrone castano opaco. Torei, di altezze e forme diverse, sono intersecabili a piacere fra loro per costruire delle piccole architetture d'appoggio che comunicano una propensione all'ospitalità.

Finiture tavolini/ Low tables finishes Torei

p 125

Marmo bianco Carrara/
White Carrara marble



p 125

Frassino tinto nero/
Black stained ashwood



p 125

Frassino tinto rosso/
Red stained ashwood



Altre finiture/ Other finishings

Frassino naturale/
Natural ashwood



ashwood, black or red stained ashwood, to three types of marble, Carrara white, Marquiña black or Carnico grey. The base, available in a matt black painted finish, is now also available in a matt chestnut brown finish. Torei, in different heights and shapes, can be intersected to create an architecture of different surfaces that convey a feeling of hospitality.

Marmo grigio Carnico/
Grey Carnico marble



a

Noce canaletto/
American walnut



ITA

ENG

02. Torei Luca Nichetto 2012

The Torei collection of graphic tables was designed in 2012 by Luca Nichetto, a young Venetian architect working in industrial design, a field in which he has excelled with some major partnerships. The series of small tables, constantly evolving, has been expanded to include different shapes, round, square, triangular and different materials, from natural

ashwood, black or red stained ashwood, to three types of marble, Carrara white, Marquiña black or Carnico grey. The base, available in a matt black painted finish, is now also available in a matt chestnut brown finish. Torei, in different heights and shapes, can be intersected to create an architecture of different surfaces that convey a feeling of hospitality.



mod. 249

Volage EX-S

126

Philippe Starck
2016

Rivestimento divano/
Sofa upholstery
Volage EX-S



p 127

Pelle/Leather
Extra 13Y274

ITA

La collezione Volage EX-S è il risultato di un percorso teso a ripensare al divano classico. Grazie ad un abaco completo, questo divano componibile è la risposta raffinata per chi cerca eleganza senza tempo per tutte le tipologie di ambienti living. Una lavorazione capitonné evoluta, che sostituisce il bottone tradizionale con un semplice ed elegante punto con attacco celato all'interno, il confort sempre più ricercato extra soft, come sottolinea il suo nome EX-S, la cura meticolosa dei dettagli, conferiscono agli elementi della collezione un aspetto fresco e contemporaneo.

ENG

The Volage EX-S collection is the result of a continuing quest to reinterpret the classic sofa. Thanks to a full range of elements, this modular sofa is the elegant response to people seeking

timeless elegance for all kinds of living spaces. A new capitonné technique, which replaces the traditional button with a simple and elegant stitch with hidden inner fastening, sophisticated,

extra-soft comfort, as underlined by the name EX-S, and painstaking attention to detail, together give the elements of the collection a fresh and contemporary appearance.





01



Gerrit T. Rietveld

1888–1964

ITA

In Gerrit T. Rietveld, nato a Utrecht nel 1888, sembrano emergere due personalità, così ben definite da far sembrare la sua opera come non appartenente ad un unico artista. La prima, quella dell'ebanista artigiano del linguaggio primordiale, che reinventa sedie e mobili, la seconda, quella dell'architetto, impegnato ad affermare nel contesto dell'architettura europea la tesi razionalistica e neoplasticista. Nel 1918 Rietveld aderisce al movimento "De Stijl", costituitosi attorno all'omonima rivista fondata l'anno prima da Theo van Doesburg. Il gruppo traduce in ideologia le leggi sulla scomposizione dinamica, già espresse in pittura dal cubismo. Tra le sue opere più importanti sono da ricordare: casa Schröder a Utrecht del 1924, il padiglione olandese alla Biennale di Venezia del 1954, il Sonsbeek Pavilion ad Arnhem e il Museo Van Gogh ad Amsterdam del 1955. Tra i suoi mobili, altrettanto importanti, Cassina ha scelto per la sua produzione, la "Red and Blue" (1918), la "Zig-Zag" (1934), la poltrona e il divano "Utrecht" (1935).

ENG

Gerrit Thomas Rietveld, born in Utrecht in 1888, seems possessed of two personalities, each so distinct that one might take his work to be that of more than one artist. The first personality is that seen in the craftsman cabinet-maker working in a primordial idiom, re-inventing chairs and other furniture; the second is that of the architect working with elegant formulas, determined to drive home the rationalist and neoplastic message in the context of European architecture. In 1918 Rietveld joined the "De Stijl" movement which had sprung up around the review of that name founded the year before by Theo van Doesburg. The group assimilated and translated into ideology certain laws on the dynamic breakdown of compositions that had already been expressed in painting by the cubists. Among his most important works are: the Schröder house at Utrecht (1924); the Dutch pavilion at the Venice Biennial (1954); the Sonsbeek Pavilion in Arnhem and the Van Gogh Museum in Amsterdam (1955). Out of his equally important furniture, Cassina has chosen for its own production: the "Red and Blue" (1918), the "Zig-Zag" (1934), the "Utrecht" armchair and sofa (1935).



1

1. Rietveld davanti all'ingresso del suo laboratorio in Adriaan van Ostadelaan 25 ad Utrecht, 1917/ Rietveld in front of the furniture workshop at 25, Adriaan van Ostadelaan, Utrecht, 1917.

01. Utrecht 1935/1988 Collezione "Cassina iMaestri"

ITA

Rietveld, architetto olandese dalla forte carica sperimentale, tra i fondatori con Mondrian del movimento neoplasticista de stijl nel 1917, disegnò il modello Utrecht nel 1935: questo modello fu creato per il grande magazzino Metz&co di Amsterdam, quindi pensato per la grande distribuzione, e rappresenta la scelta di Rietveld di adottare un approccio al comfort e al relax maggiormente "orientato al mercato". Un esempio di scomposizione degli elementi, sottolineato dalle impunture a vista previste in due tipologie (punto cavallo o zig zag) in cinque colori differenti.

ENG

Rietveld, Dutch architect with a strong bent for experimentation, and one of the founders, with Mondrian, of the neo-plastic de stijl movement in 1917, designed the Utrecht model in 1935. This model was created for the Metz&co department store in Amsterdam,

hence conceived for the mass market, and represents Rietveld's decision to adopt a more "market oriented" approach to comfort and relaxation. An example of the breakdown of elements, emphasised by two types of visible stitching (saddle stitch or zig zag) in five different colours.

Finitura poltrona/
Armchair finish
Utrecht



—
Charlot
13L207



p 131
Charlot
13L196



Centraal Museum Utrecht

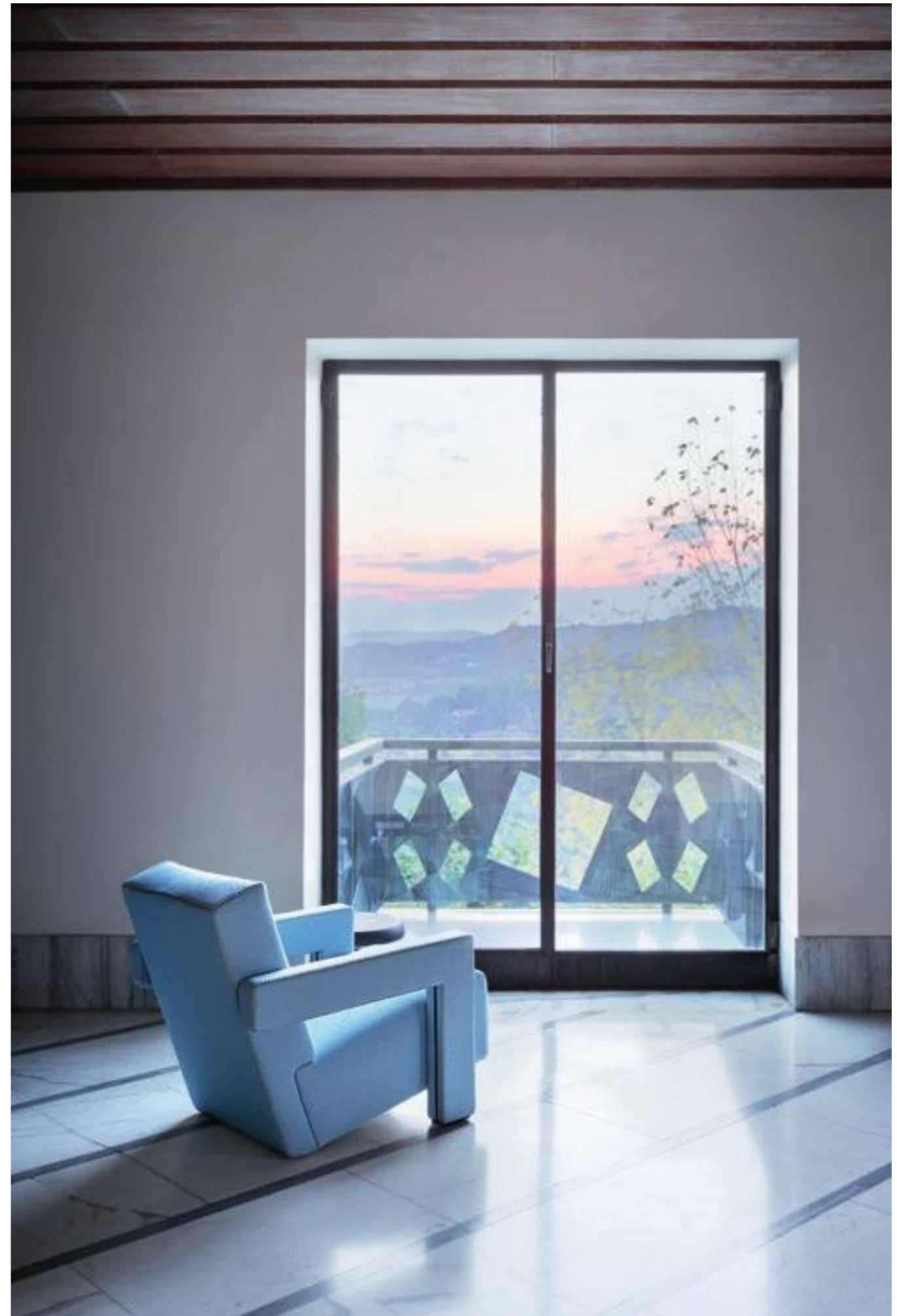



02

Rivestimento divano/
Sofa upholstery
Volage EX-S



Morandi 2
Happy 13L342

02 Specchi/Mirrors Deadline,
Ron Gilad 2016 - p 134

02. Deadline Ron Gilad 2016

ITA

Ron Gilad ha creato una nuova splendida generazione di specchi, che Cassina propone in una serie di 12 esemplari, ognuno dei quali inserito in una cornice di frassino, bianco o nero, con superfici e forme differenti: oblunghe, rettangolari, quadrate. Ma tutti hanno una caratteristica comune, quella di mettere in scena un trucco, di tradire la funzione classica dello specchio. Due specchi in una cornice a una distanza di 12 mm: lo specchio frontale è argentato e retroverniciato in diversi colori che sono riflessi dallo specchio posteriore, a creare effetti di misteriose riflettenze.

ENG

02. Deadline Ron Gilad 2016

Ron Gilad has created a splendid new generation of mirrors, which Cassina produces in a series of 12 pieces, each of which is inserted into an ashwood frame in black or white, with different surfaces and shapes: oblong, rectangular, square. They all however share

a common feature, playing tricks that betray the classic function of the mirror. Two mirrors in one frame, 12 mm apart: The front one is silver-plated, with the different colours painted on its rear side reflecting in the back mirror to create mysterious effects.



Finiture specchi/ Mirrors finishes Deadline

— Cornice disponibile in frassino tinto nero/
Frame available in black stained ashwood



— Cornice disponibile in frassino naturale/
Frame available in natural ashwood





Rivestimento divano/
Sofa upholstery
Volage EX-S

Pelle/Leather
Scozia

Happy 13L.346

mod. 250

Met

138

Piero Lissoni with S. Sook Kim
1996

Rivestimento divano/
Sofa upholstery
Met



p 139
Pelle Naturale/
Natural Leather
13Z302

ITA

Eleganza, comfort, un'ampia articolazione che permette grande flessibilità sono le caratteristiche di questo sistema. Il tratto geometrico e formale rivela un imprevisto calore nell'estremo agio e nella perfetta funzionalità offerta, grazie alle molteplici varianti: dal divano tradizionale, alle configurazioni ad angolo, per piacevoli e raccolte conversazioni fra amici, alle poltrone chaise longue per momenti di relax. Volumi semplici, puliti ed invitanti, presenze che comunicano la propria facilità ad abitare insieme a chi li utilizza.

ENG

This system is marked by elegance, comfort and a wide range of combinations allowing for great flexibility. Its geometric and formal design reveals surprising warmth in its ease of use and

perfect functionality, thanks to the many possible versions: from the traditional sofa, to corner arrangements for pleasant and private conversations among friends, to the chaise

longue for moments of relaxation. Simple, clean and inviting volumes convey the ease with which they can co-exist with those who use them.





01

Rivestimento poltrone/
Armchairs upholstery
Met

Pelle Naturale/
Natural Leather 13Z302

Rivestimento divano/
Sofa upholstery
Met

Panorama 1
Vico 13F836

01 Poltrona/Armchair Black Red and Blue (Zeilmaker Version),
Gerrit T. Rietveld 1920/2016 — p. 143



01. Red and Blue
 Gerrit T. Rietveld 1918/1973
 Collezione "Cassina iMaestri"

ITA

La poltrona Red and Blue, rappresenta un modello iconico disegnato da Gerrit T. Rietveld nel 1918. Realizzata con struttura in faggio tinto nero con sedile blu e schienale rosso in multistrato laccato. Linee e piani sono organizzati in una composizione verticale-orizzontale, collegandosi l'un l'altro senza alcun incastro. Nell'ambito del programma C90 Mutazioni, Cassina ha riproposto una delle varianti del modello iconico - Black Red and Blue Zeilmaker Version - con schienale e sedile in colore verde e struttura nera con terminali bianchi.

ENG

01. Red and Blue
 Gerrit T. Rietveld 1918/1973
 Collezione "Cassina iMaestri"

The Red and Blue armchair is an iconic model designed by Gerrit T. Rietveld in 1918. It is made with a frame in black dyed beech with blue seat and red backrest in painted plywood. Lines and surfaces are arranged in a vertical-horizontal composition, linked to one another

without any joints. As part of the C90 Mutazioni project, Cassina offers one of the versions of the iconic design - Black Red and Blue Zeilmaker Version - with backrest and seat in green and frame in black with white end parts.





Rivestimento divano/
Sofa upholstery
Met



Everest 1
Annapurna 13F364

Rivestimento pouf/
Ottoman upholstery
Met



Pelle Naturale/
Natural Leather 08 13Z304

02

02 Poltrona/Armchair Tre Pezzi Wool
Franco Albini 1959/2011. Limited Edition — p 146

02. Tre Pezzi

Franco Albini—Franca Helg 1959/2009
Collezione “Cassina iMaestri”

ITA

Il progetto risale al 1959. E oggi, dopo mezzo secolo, nell'attenta riedizione di Cassina per la collezione Cassina i Maestri, comunica ancora tutta la sua incisiva attualità.

Franco Albini, architetto dal 1929, sviluppa negli anni '40 la sua collaborazione con Cassina; nel 1952 disegna insieme a Franca Helg, sua assidua collaboratrice dal 1952, la poltrona Tre Pezzi, formulando una rilettura modernissima della classica bergère, di cui viene esplicitata la struttura formale. La profonda seduta, l'anello poggiatesta che disegna un semicerchio perfetto e il poggiatesta a mezzaluna, con la loro nitida geometria sono ben distinti l'uno rispetto all'altro. Ampi, imbottiti e avvolgenti, uniscono all'essenzialità formale una sensazione di comfort assoluto. Il tubolare metallico ripropone, nel bracciolo, il dettaglio dei corrimano della metropolitana milanese, altro progetto esemplare del Maestro.

[Rivestimento poltrona/
Armchair upholstery
Tre Pezzi](#)

Charlot 13L191



ENG

02. Tre Pezzi Franco Albini—F. Helg 1959/2009 Collezione “Cassina iMaestri”

This design dates back to 1959. And today, after half a century, the meticulous reissue by Cassina for the Cassina i Maestri collection, still conveys all of its distinct modernity. Franco Albini, an architect since 1929, forged an alliance with Cassina in the 1940s. In 1952, together with Franca Helg, his regular partner from that year on, he designed the Tre Pezzi armchair, an ultra-modern reinterpretation

of the classic bergère. The deep set, the back support ring that traces a perfect semi-circle and the half moon headrest, all have their own clean and distinct sharp geometric shape. Large, padded and embracing, they combine simplicity of form with a feeling of absolute comfort. The tubular metal of the armrests borrows the detail of the Milanese underground handrails, another design by the same Master.



mod. 241

148

Privé

Philippe Starck
2007

Rivestimento divano/
Sofa upholstery
Privé



p 149

Pelle/Leather
Extra 13Y253

ITA

Composta e formale nella sua articolazione, la collezione Privé racchiude in sé elementi di stile e trasgressione che si confondono, confluendo in un suadente mix di classicismo, provocazione e ironia.

La collezione è costituita da diversi modelli - poltrone, divani, isole di diverse dimensioni - ed è caratterizzata dal rivestimento esclusivamente in pelle capitonné, per il quale Cassina ha messo a punto una nuova tecnica di aggancio dei caratteristici bottoni in pelle. Questo sistema, brevettato a livello internazionale, garantisce qualità e durata. Privé ben si adatta ad ambienti rigorosi, pur essendo anche in grado di calarsi agevolmente in ambienti contemporanei ed informali.

ENG

Complex and formal in its design, the Privé collection perfectly combines style and transgression, merging to create an appealing mix of classicism, provocation and playfulness. The collection is made up of different models - different sized

armchairs, sofas and islands - and uses upholstery exclusively in capitonné leather, for which Cassina has developed a new technique for attaching the characteristic leather buttons. This internationally patented system provides quality

and durability. Privé is suitable for simple interiors, though it can easily blend into contemporary and informal settings.







Rivestimenti/
Upholsteries



Pelle Naturale/
Natural Leather ZZ 13Z360



01. Zig Zag

Gerrit T. Rietveld 1934/1973
Collezione "Cassina iMaestri"

ITA

La sedia, disegnata da Rietveld nel 1934, sostituisce alla normale sequenza dei componenti gambe-seduta-schienale, un foglio continuo in legno a forma di zeta rovesciata; uno dei primi esempi di sedute "a sbalzo". La qualità della falegnameria Cassina è esaltata dagli incastri a coda di rondine, visibile sul retro fra sedile e schienale. Accanto alla versione in ciliegio naturale, la sedia viene anche proposta in frassino naturale e in versione colorata con finitura a poro aperto per valorizzare le venature del legno, applicando colori puri (rosso, blu, giallo) e non-colori (bianco, nero) per i piani e frassino naturale per le sezioni laterali.

Finiture sedia/
Chair finishes
Zig Zag

a

Frassino tinto giallo/
Yellow stained ashwood



b

Frassino tinto blu
Blue stained ashwood



c

Frassino tinto rosso/
Red stained ashwood



p 157

Ciliegio naturale/
Natural cherrywood



a

b

c

ENG

01. Zig Zag

Gerrit T. Rietveld 1934/1973
Collezione "Cassina iMaestri"

Designed by Rietveld in 1934, this chair sees the normal legs-seat-back sequence replaced by a single sheet of wood in an overturned Z shape. It was also one of the first examples of a cantilevered seat. The dovetail joints, visible on the rear between the seat and the back show off the quality of Cassina carpentry.

In addition to the version in natural cherrywood, the chair also comes in natural ashwood and in a coloured version with an open-pore finish to show off the wood vein, featuring primary colours (red, blue and yellow) and non-colours (black and white) for the horizontal parts and natural ashwood for the side sections.





mod. 244

160

Myworld

Philippe Starck
2013

Rivestimento divano/
Sofa upholstery
Myworld



p 161
Airone
13K803

ITA

Myworld è un sistema living, un invito alla comodità e allo stesso tempo ad essere sempre connessi, una sfida che rispecchia le esigenze e le abitudini di un mondo in continua evoluzione in cui il lavoro e il tempo libero hanno un ruolo essenziale. Sistema di imbottiti, generosi nelle dimensioni, accoglienti e confortevoli. Sono previsti cuscini aggiuntivi, di forma quadrata con imbottitura in piuma che consentono di interpretare il proprio stile in libertà. È prevista, inoltre, una serie di complementi in grado di offrire comfort, funzionalità, risposte alle più moderne esigenze, grazie alle versioni cablate, e un buon livello di riservatezza, con paraventi da collocare intorno ai divani e alle poltrone a creare isole di privacy.

ENG

Myworld is a living space system, an invitation to comfort, yet at the same time to concentration. It is a challenge that reflects the needs and habits of an ever-changing world in which work and leisure time play an key role.

It is system of large, inviting and comfortable padded elements. Additional cushions are available, square in shape with feather padding to allow for free stylistic interpretation. There is also a series of accessories that offer comfort,

functionality and can meet the most modern needs, thanks to the cabled versions, as well as providing a good level of privacy, with screens that can be positioned around the sofas and armchairs to create islands of intimacy.





02

01

01. Wink

Toshiyuki Kita 1980

ITA

Una poltrona chaise longue versatile, a metà fra il sedile ergonomico di automobile, regolabile con una manopola, e la sagoma ironica di Topolino. Progettata nel 1980 da Kita, designer giapponese, di fama internazionale, Wink è un modello intramontabile, contro la noia visiva e l'usura del tempo, grazie alla sua trasformabilità e alla scelta dei rivestimenti intercambiabili. Nell'ambito del programma C90 Mutazioni, vengono proposti nuovi dettagli e rivestimenti in una gamma di tessuti e colori di grande attualità.

Rivestimenti poltrona/
Armchair upholsteries
Wink

p 165

Gerrit 130614
Gerrit 130645
Gerrit 130616



a

Gerrit 130622
Gerrit 130631

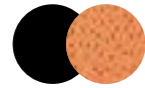

b

Gerrit 130613
Gerrit 130641



c

Gerrit 130614
Gerrit 130625
Gerrit 130615



b

c

ENG

01. Wink

Toshiyuki Kita 1980

A versatile chaise longue, a cross between an ergonomic car seat, adjustable with a knob, and the playful silhouette of Mickey Mouse. Designed in 1980 by Kita, the internationally famous Japanese designer, Wink is a timeless model,

a break away from the banal due to its transformability and range of interchangeable upholstery. As part of the C90 Mutazioni programme, it comes with new details and upholstery in an updated range of fabrics and colours.





02. Nuvola Rossa Vico Magistretti 1977

ITA

Semplicità e essenzialità sono le caratteristiche principali di questa libreria disegnata da Vico Magistretti nel 1977 e entrata in produzione nel medesimo anno.

Una libreria pieghevole che, secondo il modus operandi di Vico Magistretti nacque dall'analisi e dalla reinterpretazione degli elementi costitutivi della tipologia a fiancate e ripiani. Su questa base, l'oggetto fu ricondotto alle sole diagonali di controventatura, utilizzare anche come struttura portante per i ripiani, eliminando i fianchi. Nuvola Rossa è realizzata in faggio naturale oppure laccato bianco o nero e, come ultima introduzione, la versione laccata nel colore rosso. Esiste inoltre la versione in essenza noce canaletto.

Finiture libreria/
Bookcase finishes
Nuvola Rossa

p 166

Faggio naturale/
Natural beechwood



a

Noce canaletto/
American walnut



b

Faggio laccato rosso/
Red lacquer beechwood



a

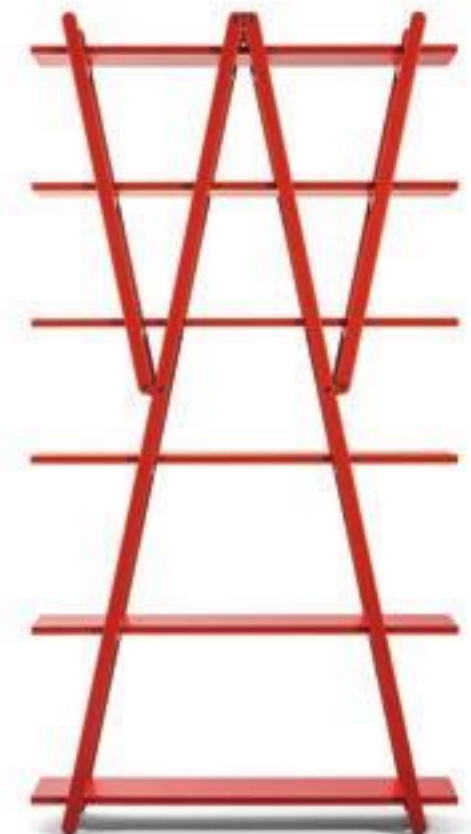

b

ENG

02. Nuvola Rossa Vico Magistretti 1977

Simplicity and essentialism are the main characteristics of this bookcase designed by Vico Magistretti in 1977 and produced in the same year. A foldable bookcase which, according to Magistretti's modus operandi, sprang from an analysis and reinterpretation a product type and the sum of its parts,

the sides and shelves. From here, the object was reduced to the diagonal brace elements, used also as a support for the shelves, thus eliminating the sides. Nuvola Rossa is made in natural beechwood, painted black or white beechwood and, more recently, in a red painted version. There is also an American walnut version.





mod. 499

Ordinal

172

Novità/News 2018

Michael Anastassiades, 2018

Finiture tavolo/Table finishes
Ordinal



p 173

Base alluminio anodizzato nero/
Black anodised aluminium base
- Piano rovere naturale/Natural oak top

ITA

Una collezione di tavoli da pranzo contemporanei e sculturali, in cui la tipica lavorazione in metallo dell'autore si unisce all'artigianalità e alla competenza della falegnameria Cassina. Il design pulito ed essenziale abbina un piano in legno di minimo spessore alle gambe sottili, in legno o in alluminio anodizzato o verniciato, poste in diagonale alle estremità del tavolo per garantire maggiore spazio ai commensali. Una sfida estrema per il Centro Ricerche dell'azienda, che ha saputo elaborare una soluzione innovativa in grado di coniugare stabilità, resistenza e spessori ridotti. L'offerta prevede due versioni quadrate, una ovale con piano laccato o impiallacciato, e due versioni rettangolari di cui una in legno massello. Quest'ultima è integrata con un meccanismo metallico regolabile, nascosto nella parte inferiore del piano, che consente di contrastare le tensioni e i movimenti del legno. I modelli con piani impiallacciati presentano preziosi bordi in legno massello.

ENG

A collection of dining tables, both contemporary and sculptural, where the designer's expertise in metalwork comes together with Cassina's crafts skills and excellence in carpentry work. This clean-cut, essential design consists of a slender table-top fitted onto super-slim legs, in wood, or anodised or painted aluminium. Set at the very end of the

table-top, and diagonally to it, the legs afford extra space to the guests. This design was especially challenging to Cassina's Research Unit, and they responded by creating an innovative solution that is not only stable, but also strong while taking up minimal space. The collection includes two square tables as well as one oval option

with a lacquered or veneer top and a solid wood trim. There are also three rectangular versions, one of which is in solid wood. The latter includes a concealed metal mechanism designed to counter the tensions and movements of the wood over time. The models with veneered tops have precious edges in solid wood.





Finitura tavolo/
Table finish
Ordinal



Base alluminio anodizzato nero/Black anodised aluminium
- Piano rovere naturale /Natural oak top

LC6

Le Corbusier, Pierre Jeanneret,
Charlotte Perriand 1928/1974
Collezione "Cassina iMaestri"

Finiture tavolo/
Table finishes
LC6



p 177

Basamento
verniciato avorio;
piano marmo/
Carrara bianco
ivory lacquered
structure; white
Carrara marble top

Finiture poltroncina
girevole/Swivel chair
finishes
LC7



p 177

Struttura verniciata
fango; pelle
Naturale 13Z200/
Mud enamel base;
Natural leather
13Z200

ITA

L'idea base di questo tavolo è la distinzione fra elemento portante, basamento, ed elemento portato, piano. L'autonomia delle due parti è sottolineata dai quattro sostegni intermedi, al tempo stesso regolatori di livello e distanziatori tra il pesante supporto e l'esile piano rettangolare. Il basamento in acciaio verniciato è proposto nei colori della palette di Le Corbusier: nero, azzurro, grigio, verde, fango e avorio con piani in cristallo, vetro stampato o nelle essenze rovere naturale, tinto nero o noce canaletto e nelle finiture marmo Carrara bianco e nero Marquiña.

ENG

The key idea at the heart of this table is to make a distinction between its load bearing base and the top that was to be supported. Each piece is completely autonomous and this is highlighted by

the addition of the four middle support pieces used to adjust the height and keep the slim rectangular top in place over its the heavy base. The steel base is enamelled in the Le Corbusier's colours palette: black, light

blue, grey, green, mud and ivory with tops in crystal, textured glass or in the finishes natural or black stained oak or American walnut and in white Carrara or black Marquiña marble.







Finiture tavoli/
Tables finishes
LC6

p 180

Basamento verniciato avorio;
piano marmo Carrara bianco/
Ivory enamel base, white
Carrara marble top



a

Basamento nero; piano
rovere naturale/Black
base; natural oak top



b

Basamento verde; piano
noce canaletto/Green
base; american walnut top



c

Basamento grigio; piano
cristallo/Grey base;
clear glass top



d

Basamento azzurro; piano
vetro stampato/Light blue
base; textured glass top



e

Basamento fango; piano
cristallo/Mud base;
clear glass top



f

Basamento nero; piano
marmo Carrara bianco/
Black base; white Carrara
marble top



mod. 195

Naan

182

Piero Lissoni
2009

Finiture tavolo/
Table finishes
Naan



p 183

Rovere tinto nero/
Black stained oak

Altre finiture/
Other finishes
Naan



—
Rovere fumigato/
Smoked oak



—
Rovere naturale/
Natural oak



—
Noce canaletto/
American walnut

ITA

Un tavolo essenziale, solo poche linee a indicare la struttura, gli spessori ridottissimi, le proporzioni non convenzionali, le misure estreme costruiscono un oggetto solido, temprato e forte. Esiste in forma rettangolare, allungabile, tutto fatto di legno in rovere fumigato, la cui colorazione penetra nelle fibre più profonde e si conserva inalterata nel tempo, rovere naturale, rovere tinto nero, noce canaletto.

ENG

A simple table, with just a few lines defining its structure, extremely reduced thicknesses, unconventional proportions and extreme dimensions to create a solid and strong object. It comes in a

rectangular shape, extendable, all in smoked oak, whose long lasting colour penetrates the deepest fibres, in natural oak, black stained oak, American walnut.





01

Finitura tavolo/
Table finish
Nään

● Rovere tinto nero/
Black stained oak

01 Sedie/Chairs Holo,
Hannes Wettstein, 2003 — p 186

01. Hola

Hannes Wettstein 2003

ITA

La sedia, disegnata dal designer svizzero nel 2003, trasmette attraverso linee semplici un codice capace di esprimere anche nel quotidiano funzionalità e comfort.

Hola ha un carattere mutevole e sorprende per la sua capacità di cambiare di volta in volta, secondo la veste che indossa. La sedia è disponibile in due versioni, con o senza braccioli, in un'ampia gamma di rivestimenti di tessuto o di pelle; esistono anche versioni con rivestimento interno in tessuto ed esterno in pelle secondo uno schema preordinato.

Rivestimenti sedie/
Chairs finishes
Hola

a

Pelle naturale 13Z304/
Natural Leather 13Z304;
Panorama 2;
Divina MD 13F287



b

Pelle Naturale 13Z307/
Natural Leather;
Charlot 13L188



c

Pelle/Leather
Scozia 13X329



d

Pelle Naturale 13Z304/
Natural Leather 13Z304
Panorama 2;
Divina MD 13F287



p 187

Pelle Naturale ZZ 13Z362/
Natural Leather ZZ 13Z362;
Gerrit 13O645



ENG

01. Hola

Hannes Wettstein 2003

The chair, conceived by the Swiss designer in 2003, uses simple lines to convey a code capable of expressing functionality and comfort even in everyday living. Hola has a mutable character and is surprising for its ability to change each time.

The chair comes in two versions, with or without armrests, in a wide range of fabric and leather upholstery. There are also versions with fabric interior and leather exterior according to a specific pattern.



mod. 475

Boboli

188

Rodolfo Dordoni
2007

Finiture tavolo/
Table finishes
Boboli

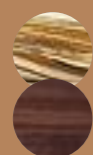

p 189

Base cromata oro;
piano noce
canaletto/
Gold chromed
base; American
walnut top

Altre finiture/
Other finishes
Boboli



Cromato/
Chrome



Cromato canna
di fucile/Gunmetal
grey chromium-
plated



Verniciato fango
opaco/Mat mud
painted

ITA

Una serie di tavoli di grande rigore geometrico e fantasia delle strutture, disegnata nel 2007 dall'architetto e designer milanese Rodolfo Dordoni. Da allora, Boboli è stato oggetto di rivisitazioni e aggiornamenti che hanno condotto alla configurazione odierna: la struttura, costituita da doghe ritorte che conferiscono al tavolo un effetto scultoreo, è stata messa a punto migliorandone la stabilità e l'estetica con l'introduzione di nuove finiture di alluminio verniciato nero opaco, cromato oro scuro, canna di fucile e color fango. Le strutture si abbinano liberamente ai piani disponibili in due essenze di legno, frassino tinto nero o noce canaletto, o in vetro retro-laccato nei colori petrolio, tortora o antracite oltre alle ultime introduzioni di due tipologie di marmo bianco Carrara e nero Marquiña.

ENG

A series of tables expressing geometric rigour and imagination in their structure, designed in 2007 by the Milanese architect and designer Rodolfo Dordoni. Since then, Boboli has been revisited and updated to its present-day configuration.

The frame, made up of twisted slats which give the table a sculptural effect, has been developed by improving its stability and look by introducing new finishes in matt black, dark chrome gold, gunmetal grey and mud painted aluminium. The frames

can be freely combined with tops available in black stained ashwood or American walnut, or in back-painted glass in petrol blue, dove grey or anthracite as well as with the latest introductions of two types of marble, Carrara white and Marquiña black.





01

Finitura tavolo/
Table finish
Boboli

Base cromata oro; piano vetro antracite/
Gold chromed base; anthracite glass top



01 Sedie/Chairs **Tulu**,
Kazuhide Takahama 1968, Cassina Simon Collezione 2013 — p 193



01. Tulu
Kazuhide Takahama 1968
Cassina Simon Collezione 2013

ITA

Uno dei primissimi modelli che hanno aperto la strada all'uso del tondino, un'evoluzione rispetto alla piegatura del tubo. Il tondino consente la produzione di strutture dalle curve morbide, molto arrotondate. La sedia ha struttura verniciata bianco opaco, nero opaco, fango opaco oppure cromata e cromata oro. Rivestimento in tessuto o pelle, completamente sfoderabile.

Finiture sedie/
Chairs finishes
Tulu

a

Struttura cromata canna di fucile; cuoio verde salvia/
Gunmetal chromed frame;
sage green saddle leather



b

Struttura cromata; cuoio nero/
Chromed frame;
black saddle leather



c

Struttura verniciata fango; cuoio blu/
Mud lacquered frame;
blue saddle leather



a



b



c

ENG

01. Tulu
Kazuhide Takahama 1968
Cassina Simon Collezione 2013

One of the very first models that paved the way for the use of the rod, an evolution from tube bending. The rod makes it possible to produce softly curved, extremely rounded structures.

The chair frame is matt white, mud or black painted or chromium- and gold chromium-plated. The fabric or leather upholstery is completely removable.



02

02. Superleggera Gio Ponti 1952

ITA

Prodotta ininterrottamente dal 1957, la Superleggera rappresenta una sintesi esclusiva tra la ricerca di Gio Ponti e la sperimentazione avanzata di Cassina, divenendo icona indiscussa di modernità e raffinatezza artigianale. Emblema dell'eccellenza costruttiva MedaMade, la sua sfida progettuale è racchiusa nella sezione triangolare delle gambe, di soli 18 millimetri e con un peso minimo di 1.700 grammi, mentre la struttura in frassino elastico e leggero si abbina al telaio del sedile in legno di faggio, più compatto e resistente al carico. Gli elementi in legno, realizzati a macchina, sono rifiniti manualmente attraverso le procedure meticolose di incollaggio a pennello, pittura dalla colla residua e impagliatura della seduta. Sapienza artigianale e innovazione industriale si incontrano così in un "oggetto primo", ispirato alle tradizionali chiavarine liguri e offerto sia nella versione classica che nelle varianti colorate con seduta imbottita.

Finiture sedia/
Chair finishes
Superleggera

a

Frassino laccato bianco/
nero, sedile rivestimento
pelle grafite X606/
Ashwood lacquered
white/black, upholst.
black leather X606



b

Frassino naturale,
Charlot 13L186/
Natural ashwood,
Charlot 13L186



c

Frassino tinto nero, sedile
canna India/Black
lacquered ashwood,
India cane seat



a



b



c

ENG

02. Superleggera Gio Ponti 1952

A highlight of Cassina's catalogue since 1957, the Superleggera represents the perfect outcome between the creative imagination of the architect Gio Ponti, and Cassina's manufacturing excellence, an undisputed icon that is both of-the-moment and pays tribute to traditional artisanal skills. Superleggera demonstrates the constructive prowess of the MedaMade craftsmen: the challenge they faced, of making an extra-light chair, was overcome with the Superleggera's legs having a cross-section of just eighteen millimetres, the whole weighing a mere 1,700

grams! While the frame exploits the inherent lightness and flexibility of ashwood, the seat surround is in beech, which is more close-grained and stronger. The wood parts are created by machine, and hand-finished, glue being applied with a brush, the excess being wiped off, and the seat being hand-woven. Thus do crafts expertise and industrial innovation come together in what we could call a "prime object", informed by the chair-making traditions of Chiavari, in Liguria, northern Italy. The Superleggera is available both in the classic version or with coloured legs, as well as with a padded seat.

Leggera

Gio Ponti 1952/2017

ITA

Un'icona del design e della maestria MedaMade. Una forma chiara, colta, versatile, in grado di soddisfare un'ampia gamma di esigenze e scenari. La sedia in legno per eccellenza segna uno dei momenti fondamentali della collaborazione progettuale ed esecutiva nata agli inizi degli anni '50 tra Gio Ponti, Cesare Cassina e gli artigiani dell'azienda. Dall'esperienza e dalla capacità della falegnameria Cassina nasce una sfida scandita dai progressivi alleggerimenti della struttura - che sfoceranno nella più esile e inimitabile Superleggera -, tesi a valorizzare la semplicità delle linee rispettandone al tempo stesso le caratteristiche di resistenza e stabilità. Le molteplici combinazioni e gli originali contrasti cromatici tra la struttura in frassino e il rivestimento della seduta rendono il modello sempre attuale e facilmente inseribile nei diversi contesti.

Finiture sedie/
Chairs finishes
Leggera

- a** Frassino tinto petrolio, Champ 13F357/Ashwood stained petroleum, Champ 13F357
- b** Frassino naturale, corda naturale/Natural ashwood, natural rope
- c** Frassino tinto nero, corda nera/Ashwood stained black, black rope
- d** Frassino tinto bianco, corda bianca/Ashwood stained white, white rope



ENG

Leggera Gio Ponti 1952

An icon of design and what has been dubbed MedaMade crafts mastery, the Leggera - its lines clean-cut refined, and versatile - adapts effortlessly to a variety of requirements and settings. A wood chair, par excellence, the Leggera marks one of the key points of the relationship, both in terms of design and production, which started in the 1950s between Gio Ponti, Cesare Cassina, and the Cassina company's artisans. The experience and the crafts capabilities of

Cassina's carpenters were put to the test in addressing the challenge of lightening the chair frame -- the ultimate outcome being the inimitable slimline Superleggera chair -- concentrating on its essential lines while respecting its resistance and stability. The many combinations and contrasts in colour between the ashwood frame and the seat-cover keep the Leggera constantly up-to-date, as well as making it a perfect partner for any setting.

Leggera / Superleggera

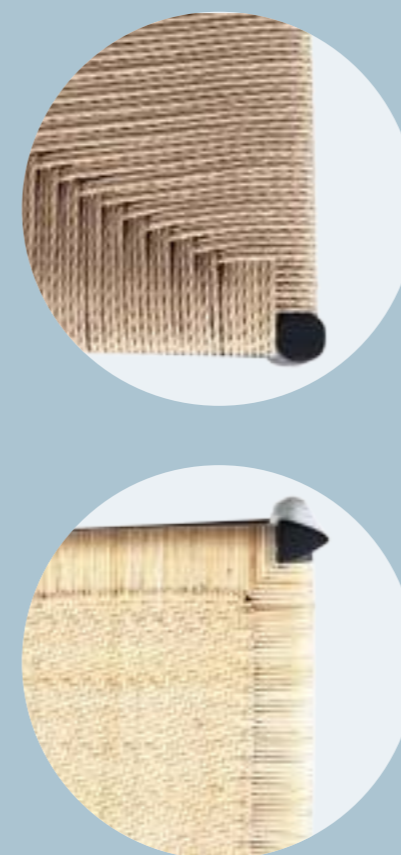

ITA

Le gambe anteriori e posteriori delle sedie hanno due differenti sezioni: quasi circolari nella sedia Leggera (mod 646), triangolari, per assottigliarne visualmente la forma, nella Superleggera (mod.699).

ENG

The front and rear legs of the chairs have two different sections: nearly circular in the Leggera (mod 646), triangular, for a visually bevelled shape in the Superleggera (mod.699).



Gio Ponti

1888–1964

ITA

Architetto, designer e artista, Gio Ponti (Milano 1891-1979) si laurea a Milano nel 1921 e si associa inizialmente con Emilio Lancia e Mino Fiocchi dal 1927 al 1933. Nel 1927 fonda il Labirinto, con Lancia, Buzzi, Marelli, Venini e Chiesa, per proporre arredi e oggetti di alto livello. Dal 1923 al 1930 è direttore artistico di Richard Ginori. Con la fondazione della rivista Domus nel 1928 (che, salvo brevi interruzioni, dirigerà fino alla morte), Ponti contribuisce intensamente al rinnovamento della produzione italiana del settore, cui dà nuovi impulsi. Partecipa da protagonista e sostiene le Biennali di Monza, poi Triennali di Milano, il premio Compasso d'oro e l'ADI (Associazione per il Disegno Industriale). Al Ponti architetto si deve il simbolo della Milano moderna, il grattacielo Pirelli, progettato nel 1956 con Fornaroli, Rosselli e Nervi. Nel 1951 realizza il secondo Palazzo Montecatini (il suo primo palazzo per uffici risale al 1938-39). Nel 1957 progetta la celeberrima Superleggera per Cassina, a coronamento di un rapporto di collaborazione lungo e fecondo. All'attività progettuale ha affiancato anche quella didattica, insegnando alla Facoltà di Architettura di Milano dal 1936 al 1961.

ENG

An architect, a designer and an artist, Gio Ponti (Milano 1891-1979) graduated in Milan in 1921 and initially entered into partnership with Emilio Lancia and Mino Fiocchi from 1927 to 1933. In 1927 he founded Il Labirinto with Lancia, Buzzi, Marelli, Venini and Chiesa in order to produce high-quality furniture and objects. From 1923 to 1930 he has been Richard Ginori's artistic director. Thanks to the creation of Domus magazine in 1928 (which he presided over almost constantly until his death), Ponti made an intensive contribution to the renewal of the Italian production in the sector, giving it new impetus. Ponti has been a strong supporter of the Monza Biennale, then the Milan Triennale, of the Compasso d'Oro awards and of ADI (Association of Industrial Design). As an architect, he created the symbol of modern Milan, the Pirelli skyscraper, designed with Fornaroli, Rosselli and Nervi in 1956. In 1951, he realised the second Palazzo Montecatini (his first office building dates back to 1938-39). In 1957 he designed the super-celebrated Superleggera chair for Cassina, the crowning achievement of a long and fruitful working association. To his planning activities, he added educational activities, teaching at the Faculty of Architecture in Milan from 1936 to 1961.



03. Cotone

Ronan & Erwan Bouroullec 2017

ITA

L'ispirazione per il progetto di questa poltroncina affonda le sue radici nei grandi classici di Cassina, a cui ci si rifà ancora oggi come esempio di capacità di realizzare modelli dal notevole carattere espressivo, con alti contenuti artigianali e industriali. È da queste basi che si materializza la poltroncina a quattro gambe, che si fa notare subito per il forte contrasto esistente fra la minimale struttura portante rigida, rigorosa e molto elegante, prodotta in alluminio con profili estrusi, realizzati appositamente per questo modello. La struttura sorregge la seduta molto morbida, accogliente, tutta realizzata in piuma, che sembra quasi appoggiata: il comfort di una poltrona per una poltroncina da tavolo, che invita alla seduta e al relax. Un progetto ricco, dall'elevato valore progettuale e produttivo per la minuziosa attenzione al dettaglio, che si presta all'utilizzo domestico, intorno ad un tavolo da pranzo, oppure in contesti più ampi, intorno a tavoli riunioni. La struttura portante è proposta in differenti versioni di alluminio: verniciato nero opaco, oppure anodizzato naturale o nei colori rosso opaco, grigio_blu opaco, verde o rame. La parte imbottita interna è realizzata in poliuretano espanso rivestito da un soffice e confortevole trapuntino in piuma, rivestita in tessuto o pelle.

Finiture sedie/
Chairs finishes
Cotone

p 199

Alluminio verniciato nero opaco/Mat black painted aluminium;
Pelle Scozia 13X202



a

Alluminio anodizzato rosso opaco/Mat red anodized aluminium; Everest 2-Annapurna 13F365

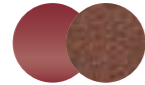

b

Alluminio anodizzato naturale/Aluminium natural anodized; Everest Masai 13O082

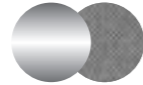

198

ENG

03. Cotone

Ronan & Erwan Bouroullec

The inspiration for the design of this armchair is rooted in the great classics of Cassina, once again the benchmark or its ability to create highly expressive models with high-end artisanal and industrial content.

These are the foundations for a 4-legged armchair that immediately stands out for the strong contrast between its minimalist, rigorous and highly elegant rigid supporting structure, produced from aluminium with extruded profiles, specially created for this model, and the seat: very soft and welcoming seat, produced entirely from down, which almost seems to be propped up. The comfort of an

armchair for a dining table chair that invites the user to sit and relax.

A rich project with great design and production value due to its minute attention to detail, suitable for domestic use, around the dinner table, or in broader contexts, around meeting tables. The aluminium supporting structure comes in different versions: lacquered matt black or natural anodised, or in the colours matt red, matt grey-blue, green or copper.

The internal padded part is in polyurethane foam covered with a soft and comfortable down quilt, upholstered in fabric or leather.



199



03

Finitura tavolo/
Table finish
Boboli



Base verniciata nero opaco, piano marmo Marquina/
Mat black painted base, Marquina marble top

03. Sedia/Chair Cotone,
Ronan & Erwan Bouroullec 2017 — p 198

Cotone Slim Ronan & Erwan Bouroullec 2018

ITA

Il comfort di una poltrona per una poltroncina da tavolo, un elegante invito alla seduta e al relax da oggi proposto anche in versione Slim. Gli autori si ispirano ai grandi classici di Cassina, definiti da uno scheletro portante che esemplifica la capacità dell'azienda nella produzione di modelli di grande raffinatezza espressiva. Il design si distingue per il contrasto deciso tra la linea minimale e rigorosa della struttura, realizzata in alluminio con profili estrusi concepiti appositamente per il modello, e la forma morbida e accogliente della seduta. La struttura è proposta in differenti versioni di alluminio mentre l'imbottitura interna in poliuretano espanso è rivestita in pelle o tessuto ma priva del trapuntino in piuma.

[Finiture sedie/
Chairs finishes
Cotone Slim](#)

a

Alluminio verniciato nero opaco/Mat black painted aluminium; Cuoio/Leather Naturale ZZ 13Z360



b

Alluminio anodizzato naturale/Aluminium natural anodized; Sutra 13F925 Fango

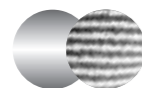

a



b

Novità/News 2018

ENG

Cotone Slim Ronan & Erwan Bouroullec

A low-armed dining chair that is as comfortable as an armchair proper, elegantly extends an invitation to sit and relax; a brand-new slim-line version is also now available. The designers of Cotone and Cotone Slim took their cue from the great Cassina classics, and their skeleton frame that exemplifies the company's ability to produce highly expressive and exquisitely refined

pieces year after year. The key to the design of Cotone is the strong contrast between the frames rigorous, minimal line, which is made of aluminium with extruded profiles created exclusively for this piece, and the soft, welcoming look of the seat. The frame is available in a number of aluminium finishes, while the polyurethane padding is supplied in leather or fabric, but without the feather-quilted cover.

Cotone Legno Ronan & Erwan Bouroullec 2018

ITA

La famiglia Cotone si amplia aggiungendo alla poltroncina imbottita, introdotta nel 2017, una sua versione Slim, un tavolo e una sedia con seduta e schienale in massello, prodotta nella falegnameria di Meda impiegando macchine a controllo numerico avanzato. I vari modelli della collezione possono essere combinati liberamente in base ai propri gusti ed esigenze grazie alla tipica struttura con telaio in alluminio estruso caratterizzato da sofisticati dettagli industriali, emblema della maestria costruttiva di Cassina. Il sedile e lo schienale in massello di legno di frassino si uniscono alla base in alluminio per creare una forma estremamente contemporanea, leggera e dalle dimensioni minimali. Il telaio anodizzato, disponibile nella stessa gamma colori degli altri arredi, contrasta nettamente con gli elementi in frassino tinto nero, mentre la versione verniciata in nero, con sedile e schienale in frassino tinto nero, si propone come opzione più raffinata.

[Finiture sedie/
Chairs finishes
Cotone Legno](#)

a

Alluminio anodizzato naturale/Aluminium natural anodized; Massello di frassino tinto nero/Solid wood black stained ashwood



a

Novità/News 2018

ENG

Cotone Wood Ronan & Erwan Bouroullec

The Cotone family has acquired new members to go with its upholstered armchair that was launched in 2017. These are a slim version of the same, called, not surprisingly, Cotone Slim, as well as a table and chair, the latter having a solid wood seat and back. This chair is produced, using advanced CNC machinery, in Cassina's carpentry workshop in Meda, in the Brianza area north of Milan. The various elements in the collection can be mixed and matched according to ones preferences and requirements, thanks

also to the frame in extruded aluminium, with its eye-catching industrial details, a veritable emblem of Cassina's furniture-making mastery. The seat and back, in solid ashwood, slot into the anodised aluminium frame to create a highly contemporary look, light-weight but also super-slender. The frame, available in the same colours as the other pieces, creates a clever contrast with the black seat and back; with a gloss black frame, Cotone Legno takes on an extra touch of refinement.

Cotone

Ronan & Erwan Bouroullec 2018

ITA

La famiglia Cotone si amplia aggiungendo alla poltroncina imbottita, introdotta nel 2017, una sua versione Slim, un tavolo e una sedia con seduta e schienale in massello. I prodotti della collezione si distinguono per il telaio in alluminio estruso caratterizzato da sofisticati dettagli industriali, grazie al quale si possono combinare liberamente tra loro gli arredi in base ai gusti e alle esigenze. Il tavolo dal design semplice ma ben definito presenta un telaio in quattro varianti rettangolari e in versione quadrata, disponibile nella stessa varietà di colori delle sedie. Elemento distintivo e riconoscibile, il telaio in alluminio conferisce leggerezza e resistenza al tavolo creando un contrasto elegante con i materiali naturali del piano e con le gambe sottili che consentono di accogliere un numero ampio di commensali. Le misure sviluppate sono complementari e integrative rispetto all'ampia offerta di tavoli della collezione Cassina

Novità/News 2018

Finiture tavolo/
Table finishes
Cotone

a

Alluminio anodizzato naturale/Aluminium natural anodized; Massello di frassino tinto nero/Solid wood black stained ashwood



b

Alluminio anodizzato naturale/Aluminium natural anodized; Marmo/Marble Marquina



c

Alluminio anodizzato naturale/Aluminium natural anodized; Marmo/Marble Carrara



ENG

Cotone Ronan & Erwan Bouroullec

The Cotone family has acquired new members to go with the upholstered armchair launched in 2017. These are a slim version of the same, called, not surprisingly, Cotone Slim, as well as a table and chair, the latter having a solid wood seat and back. The products in this collection all feature an extruded aluminium frame characterised by sophisticated industrial details. Thanks to these, the pieces can be mixed and matched, according to ones tastes and requirements. The table, which has a simple yet

eye-catching design, comes in four rectangular and one square size, the frame being available in the same colours as the chairs. Distinctive and immediately recognisable, the aluminium frame, both light and strong, conjures an elegant contrast with the natural materials used for the top, and well as with the legs, whose slender lines allow several people to sit around the table in comfort. The new sizes complement, and integrate, the wide range of tables currently belonging to the Cassina catalogue.



a



b



c

mod. W01

Doge

204

Carlo Scarpa
1968/2016

Finiture tavolo/
Table finishes
Doge



p 205

Base alluminio
lucido rame; piano
marmo Carrara
bianco/Polished
aluminium copper
colour; white
Carrara marble top

ITA

Il tavolo Doge, progettato da Carlo Scarpa, è entrato a far parte di Cassina Simon Collezione a seguito dell'acquisizione della storica azienda Simon avvenuta nel 2013. Nel 1968 Simon aveva iniziato la propria produzione con questo eccezionale capolavoro, uno dei capisaldi del movimento "Ultrarazionale", il cui scopo era di superare i rigorosi limiti del razionalismo.

Nell'ambito del programma C90 Mutazioni, Doge è stato oggetto di nuove introduzioni di finiture e materiali: oltre alla versione originale in acciaio, la struttura del tavolo è ora disponibile in alluminio lucido, color canna di fucile e rame lucidi oppure rosso opaco. I piani sono proposti in cinque dimensioni, nella versione vetro float o in due versioni di marmo, bianco Carrara e nero Marquiña.

ENG

The Doge table, designed by Carlo Scarpa, became part of the Cassina Simon Collection following the acquisition of the long established company Simon in 2013. Simon launched its own production in 1968 with this exceptional masterpiece, one of the cornerstones

of the "Ultrarazionale" movement, whose aim was to go beyond the strict limitations of rationalism by exploring different materials and with quality expressed through precious details to create a powerful figurative whole. As part of C90 Mutazioni, Doge was given new finishes

and materials: besides the original version in steel, the table frame is now available in polished aluminium, polished gunmetal, polished copper or matt red versions. The tops come in five sizes in float glass or in two types of marble, Carrara white or Marquiña black.





Carlo Scarpa

1906–1978

ITA

Dalle architetture ai vetri, dai progetti di design agli allestimenti museali, l'opera di Carlo Scarpa si distingue sempre per l'inconfondibile tratto con cui riesce a coniugare l'amore per i materiali, l'attenzione al dettaglio e la sapiente elaborazione delle poetiche wrightiane e organiche. Architetto, progettista, artista, Scarpa lascia l'Accademia d'Arte di Venezia nel 1926 e inizia l'attività come professionista, mantenendo contemporaneamente la frequentazione con le botteghe artigiane e con i maestri vetrai veneziani. Per venti anni, fino oltre la metà degli anni quaranta, riceve numerosi incarichi per la progettazione di edifici, per ristrutturazioni ed allestimenti.

ENG

From architecture to works in glass, from design projects to preparing museum exhibitions, the work of Carlo Scarpa has always stood out in the unmistakable way in which it manages to bring together his love for materials, his attention to detail and his masterly elaboration of organic and Wrightian poetics. Architect, designer and artist, Scarpa left the Venice Academy of Art in 1926 and began professional work, but continued to visit craftsmen's workshops and Venetian master glassworkers. For twenty years, right up until the second half of the Forties, he received numerous commissions to design, convert prepare buildings.

ITA

“L'architettura [...] dovrebbe trovare delle ragioni razionali che io chiamo di superiorità razionale, cioè di logica ineluttabile, che non ha niente a che fare col funzionalismo o col razionalismo. Anzi direi che mi metto sempre in posizione critica, in opposizione, perché per me esiste una logica superiore che è poi quella della conquista della forma.”

Carlo Scarpa

ENG

Architecture [...] needs to seek out rational reasons, of what I call rational superiority, i.e. reasons of indisputable logic, that have nothing to do with functionalism

or rationalism. In fact I'd say that I tend to always take a critical line, going against the current, as for me there is a logic that transcends the mere conquest of form.



1

1. Pier Giacomo Castiglioni, Carlo Scarpa, Achille Castiglioni, Dino Gavina nel negozio Gavina a Milano, 1963/Pier Giacomo Castiglioni, Carlo Scarpa, Achille Castiglioni, Dino Gavina in the Gavina store in Milan, 1963.

Ph. FCottì Milano, Bologna Archivio Gavina



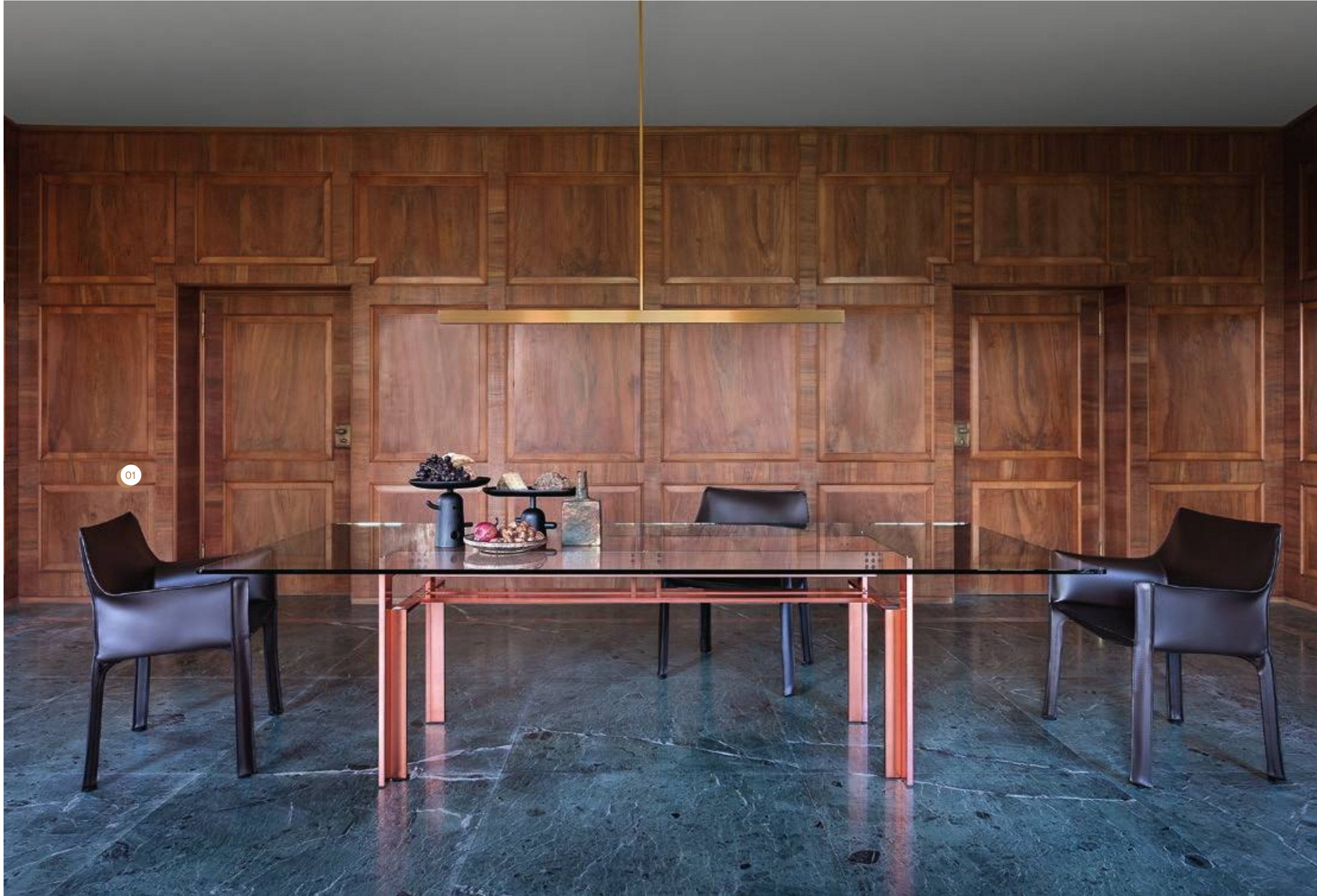

01

Finitura tavolo/
Table finish
Doge

Base alluminio lucido rame; piano vetro float/
Polished aluminium copper colour; float glass top



01 Poltroncina/Small armchair MB10 413 Cab.
Mario Bellini 1977 — p.211



01. CAB
Mario Bellini 1977

ITA

Cab fu concepita dall'architetto Mario Bellini, nel 1977, come prolungamento e protesi del corpo: uno scheletro in tubolare di acciaio e una pelle tesa in cuoio cucito, fermato alla struttura da quattro cerniere lampo. In versione sedia oppure poltroncina con braccioli, è proposta in cuoio in una vastissima palette di colori e in cuoio pigmentato in tre varianti cromatiche. Cab fa parte della collezione del MoMA di New York ed è, a tutt'oggi, uno dei modelli best-seller di Cassina.

Rivestimenti sedie/
Chairs upholstery
412 Cab

p 210

Cuoio rosso bulgaro/
Russian red saddle leather



a

Cuoio grigio/
Grey saddle leather



b

Cuoio radica/
Briar root saddle leather



c

Cuoio rosso bulgaro/
Russian red saddle leather



d

Cuoio blu/
Blue saddle leather



e

Cuoio talpa/
Taupe saddle leather



f

Cuoio porcellana/
Porcelain saddle leather



g

Cuoio beige/
Beige saddle leather



h

Cuoio cognac/
Cognac saddle leather



i

Cuoio verde salvia/
Sage green saddle leather



ENG

01. CAB
Mario Bellini 1977

Cab was conceived by the architect Mario Bellini in 1977, as an extension and prosthesis for the body: a skeleton in tubular steel and stretched, stitched leather, fastened to the frame with four zips. In a chair version or as an armchair with

armrests, it comes in saddle leather in a vast assortment of colours and in pigmented saddle leather in three different shades. Cab is part of the collection at the MoMA in New York and remains one of Cassina's bestsellers.

mod. MB5 452

212

La Rotonda

Mario Bellini
1976

Finiture tavolo/
Table finishes
La Rotonda



p 213

Base noce
naturale/
Piano cristallo
Natural walnut
base/Clear
glass top

ITA

Questo tavolo, disegnato dall'architetto Mario Bellini nel 1976, ha una base semplice e scultorea, un incrocio diagonale di tre gambe a sezione quadrata, che consente l'appoggio del piano di Ø 165 cm, unite da incastri solidi, ricavati direttamente dal massello, massima espressione della capacità di lavorare il legno di Cassina. La base è realizzata in frassino naturale, tinto noce o tinto nero, noce naturale, noce tinto noce o noce canaletto con piano in cristallo; le basi in frassino naturale, noce naturale e noce tinto noce possono avere il piano nella medesima essenza. La Rotonda esiste anche in versione tavolino basso con piano Ø 125 cm solo in cristallo con base in frassino naturale o tinto nero, noce naturale o noce canaletto.

ENG

This table designed by architect Mario Bellini in 1976 has a simple sculpted base, a diagonal intersection of three legs with square cross section, which supports a Ø 165 cm table top, bound together by strong joints carved directly from the solid wood, the utmost

expression of Cassina's wood craftsmanship. The base is made from natural ashwood, walnut or black stained ashwood, natural walnut, walnut-stained walnut or American walnut with crystal top; the natural ashwood natural walnut and walnut-stained walnut

bases can have the surface in the same wood. La Rotonda also exists as a low side table with a Ø 125 cm top only in glass with base in natural or black stained ashwood, natural walnut or American walnut.







Tappeti/Rugs

ITA

Un tempo acquistare un tappeto significava principalmente acquistare un tappeto persiano o caucasico, annodato a mano, prezioso e a volte costoso. Molto spesso qualità e origine del tappeto erano più importanti del colore e del disegno.

Oggi, le esigenze sono spesso orientate verso scelte più pratiche, pur non volendo rinunciare a valori estetici e di design. La selezione di Cassina è stata condotta allo scopo di offrire una serie di complementi di arredo di elevata qualità, in grado di coordinarsi, valorizzare e completare le proposte di ambientazioni.

Le scelte si sono ampliate e, volendo rispondere ad esigenze più dinamiche, l'impiego di fibre naturali e sintetiche hanno consentito la realizzazione di tappeti, come complementi di arredo, che grazie a caratteristiche tessili e cromatiche, ben si collocano in ambienti residenziali, classici o moderni.

ENG

Buying a rug used to generally mean a Persian or Caucasian rug, hand knotted, precious and sometimes expensive. Very often, the quality and origin of the rug was more important than the colour and design. Today, demands are often orientated towards more practical choices, which nevertheless do not forgo aesthetics and design.

The Cassina selection offers a series of high

quality furnishing accessories, capable of matching, enhancing and completing an interior. The selection has been expanded and, to meet more dynamic demands, the use of natural and synthetic fibre has allowed for rugs to be made as furnishing accessories, whose woven and colour features adapt well to classic as well as modern domestic settings.

Maglia

ITA

Fique è una fibra versatile e robusta, di origine colombiana, un tempo utilizzata per la produzione di sacchi di caffè e filati per l'agricoltura: oggi il materiale naturale viene filato a mano per essere poi lavorato a maglia su lunghi aghi apposti per realizzare tappeti di bellezza unica. Non a caso, Maglia è il nome della collezione, che viene proposta in cinque tonalità. L'irregolarità del materiale, attraverso la lavorazione artigianale, produce uno splendido motivo, ricco di autenticità.

ENG

Maglia

Fique is a strong, versatile fibre from Colombia and once used to make coffee sacks and agricultural yarns. Today, the natural fibre is hand spun before being knitted on special long needles for making uniquely beautiful rugs.

Maglia, which means knit in Italian, is hence the name of the collection, which comes in five colours. The irregular nature of the material, which is created by hand, produces a splendid and authentic pattern.

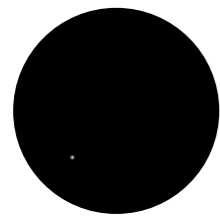

Carbone/Coal



Salmone/Salmon

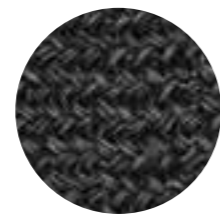

Azzurro/Light blue

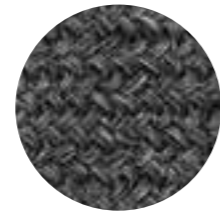

Beige/Beige

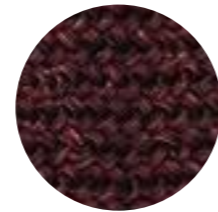

Ruggine/Rus

Atacama 2

ITA

Atacama 2 è una collezione di tappeti realizzati in seta di bambù, una fibra naturale derivata dall'omonima pianta, molto versatile ed estremamente resistente. I tappeti hanno un aspetto brillante, liscio e soffice come la seta. Sono annodati a mano, con circa 155.000 nodi per metro quadro con una struttura denominata "a loop". Questo materiale fa risaltare i dettagli della superficie, assorbe e riflette la luce e le nove tonalità, in cui vengono proposti i tappeti, vengono impreziosite da variazioni e sfumature, con effetti cromatici luminescenti. I tappeti Atacama 2 possono presentare variazioni cromatiche, simbolo di bellezza e preziosità dei tappeti realizzati a mano.

ENG

Atacama 2

Atacama 2 is a collection of rugs crafted from bamboo silk, a highly versatile and extremely durable natural fibre derived from the bamboo plant. The rugs are brilliant, smooth and soft like silk. Each rug is knotted by hand, with around 155,000 knots per square metre hooked in a loop structure. The material highlights the details of

surfaces, absorbing and reflecting light, while the nine different available colours are embellished with unique details and shades with luminescent tonal effects. The Atacama 2 rugs may display slight colour variations, which are a symbol of the beauty and preciousness of hand-crafted rugs.

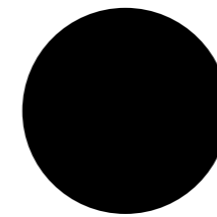

Blu scuro/Dark blue



Giallo/Yellow



Cammello/Camel

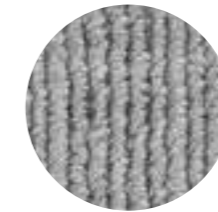

Sabbia/Sand

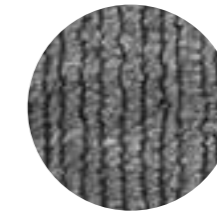

Grigio-Beige/Greige

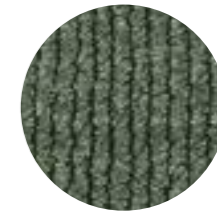

Verde Salvia/Sage green

Novità/News 2018



Vinaccia/Red-purple

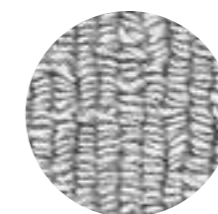

Cenere/Ash gray

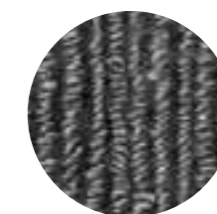

Antracite/Anthracite

Cuscini/Cushions

220

ITA

Una linea di soffici cuscini in piuma, quadrati o rettangolari, singoli oppure a set di 2 o 3 pezzi, proposti in diverse dimensioni per assolvere svariate esigenze e dare vita a invitanti oasi, per creare il proprio stile in libertà, oppure disposti in modo ordinato e rigoroso, per situazioni più formali. I cuscini sono realizzati nelle varie tipologie di tessuti e pelli in collezione, nelle medesime cromie, per un perfetto abbinamento con i rivestimenti dei divani, oppure in differenti tonalità per creare piacevoli contrasti.

Collezione cuscini/
Cushions collection

a
code 092 01
Cuscino in piuma
con fascia/Feather
cushion with band
50x50 cm - 19.7"x19.7"
Gerrit 13O622

b
cod. 092 03
Cuscino in piuma con
fascia/Feather cushion
with band 45x45 cm
17.7"x17.7" Morandi 1
Canasta 13L340

c
cod. 090 40
Cuscino in piuma/
Feather cushion
40x40 cm
15.7"x15.7"
Gerrit 13O616

d
code 250 05
Cuscino in piuma/
Feather cushion
55x55 cm - 21.6"x21.6"
Everest 2
Rock 2 13O509

e
cod. 092 01
Cuscino in piuma
con fascia/Feather
cushion with band
50x50 cm - 19.7"x19.7"
Pelle Naturale ZZ 13Z362

f
cod. 090 50
Cuscino in piuma/
Feather cushion
50x50 cm - 19.7"x19.7"
Everest 2
Annapurna 13F365

g
code 250 05
Cuscino in piuma/
Feather cushion
55x55 cm - 21.6"x21.6"
Everest 2
Annapurna 13F364

h
cod. 090 55
Cuscino in piuma/
Feather cushion
55x55 cm - 21.6"x21.6"
Morandi 1
Happy 13L342

i
code 675 C3
Cuscino poggiaresi
in piuma/Feather
back cushion
65x27 cm - 25.6"x10.6"
Morandi 2 13L344

l
code 250 05
Cuscino in piuma/
Feather cushion
40x40 cm - 15.7"x15.7"
Champ 13F356

m
Cuscino poggiaresi
in piuma quadrato/Square
feather padded back
cushion 31x31 cm -
12.2"x12.2" Arat 2 13F334

n
code 675 C2
Cuscino poggiaresi
in piuma/Feather back
cushion 55x27 cm -
21.6" x 10.6" Champ 13F353

p
code 675 C1
Cuscino poggiaresi
in piuma/Feather back
cushion 45x27 cm
17.7"x10.6" Everest 1
Pilot 13O118

o
cod. 090 60
Cuscino in piuma/
Feather cushion
60x60 cm - 23.6"x23.6"
Everest 1
Nepal 13O107

ENG

A line of soft down cushions, square or rectangular, single or in sets of two or three, available in different sizes to meet various needs and add warmth to inviting seating oases, for unfettered personal style, or laid out in an orderly,

precise manner in more formal settings. The cushions are made from the various kinds of fabric and leather in the collection, in the same colours to perfectly match sofa upholstery, or in different shades to create pleasing contrasts.



221

Marchiatura/Identifying marks

ITA

Ogni mobile della Collezione "Cassina I Maestri" porta impressi indelebilmente:
 — la firma dell'Autore, la cui proprietà è dei legittimi Eredi ed il cui uso è stato concesso in esclusiva a Cassina;
 — il logotipo "Cassina I Maestri" nel quale è inserito il marchio di riconoscimento dell'autore;
 — il numero progressivo, che identifica l'oggetto in collegamento con la sua "Carta d'Identità", testimonia l'avvenuto controllo finale di qualità e consente agli Eredi il controllo dell'esatta corresponsione dei diritti d'Autore.

ENG

Each piece of furniture in the "Cassina I Maestri" Collection is indelibly marked with:
 — the signature of the Author, whose copyright belongs to his heirs, the use of which has been granted exclusively to Cassina;
 — the "Cassina I Maestri" logotype, which incorporates the Author's emblem;
 — the production number which tallies the item with the "Identity Card" and shows that a final quality check has been carried out, allowing the Heirs' control as far as compliance with copyright is concerned.

Cassina  N° _____ *Franco Albini*

Cassina  N° _____ *Ch. Perruccio*

Cassina  N° _____ *Eliel Saarinen*



Cassina  N° _____ *Nieuw*

Cassina  N° _____ *C. R. Mackintosh*

Cassina  N° _____ *Frank Lloyd Wright*

Cassina  N° _____ *Le Corbusier*

Cassina  N° _____ *Charles Mollino*

Cassina   N° _____ *Le Corbusier G. Jeanm. Ch. Perruccio*



Disegni tecnici/Technical drawings

553 Bowy Sofa

p 15

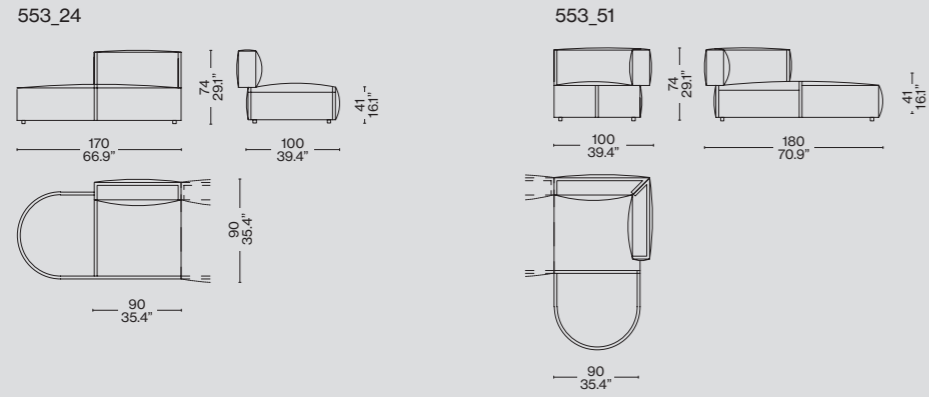

p 16-17

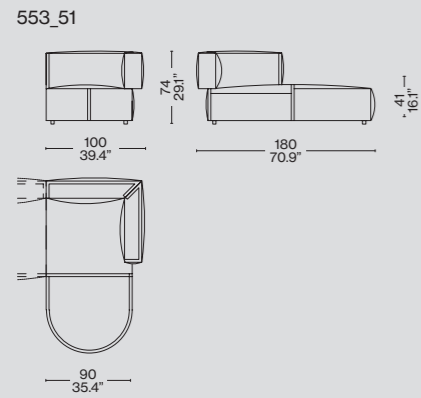
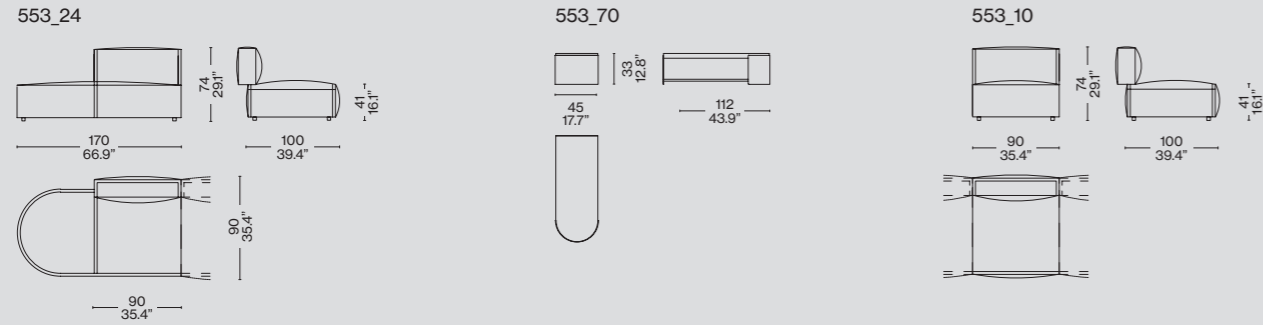

p 16-17

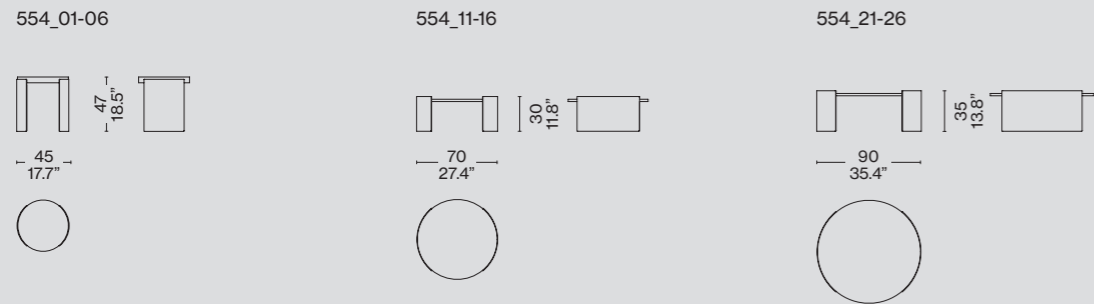

550 Beam Sofa System

p 21

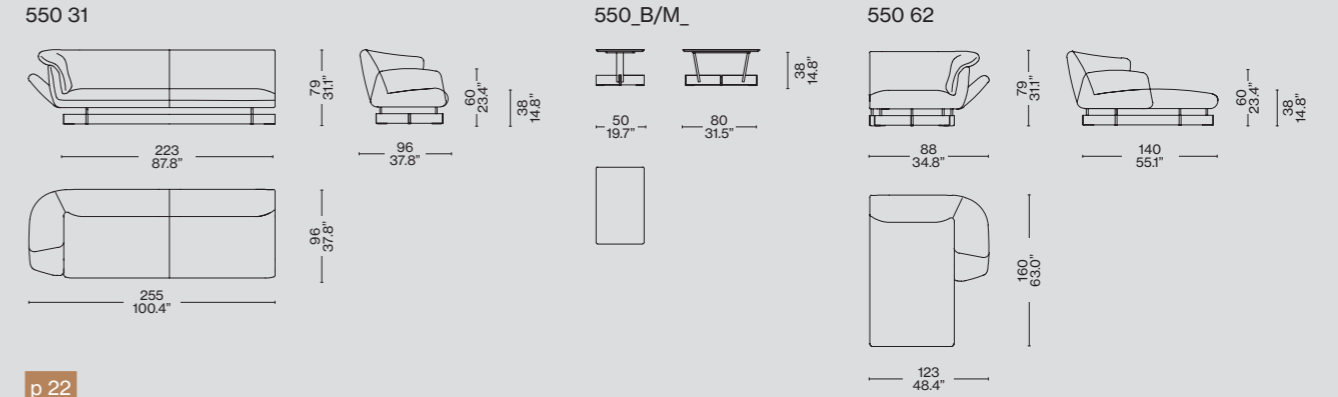

p 22

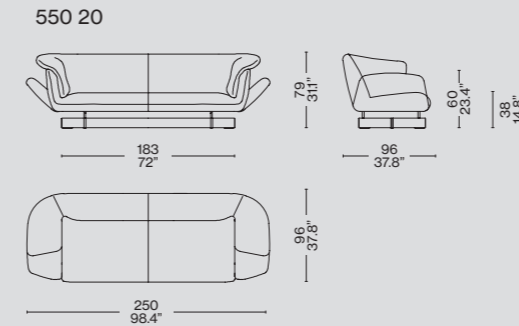

p 23, 24-25, 28-29

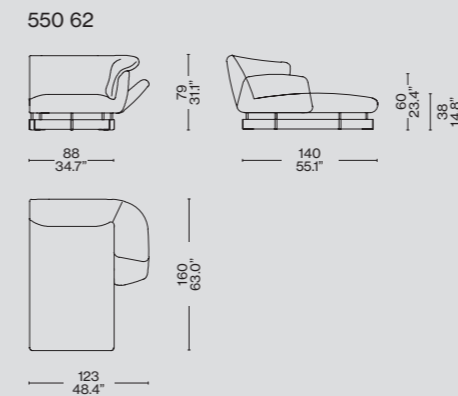
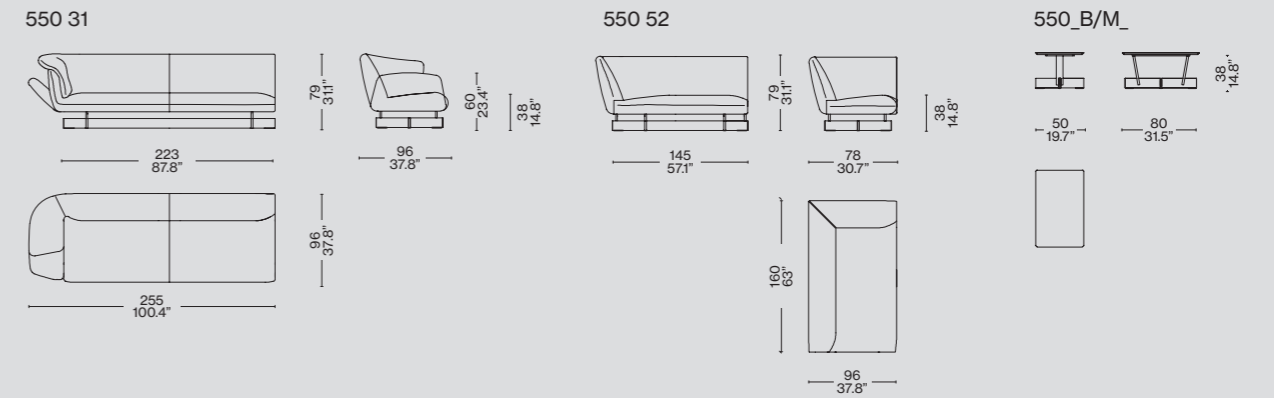

2028

p 36-37, 38-39, 48-49, 50

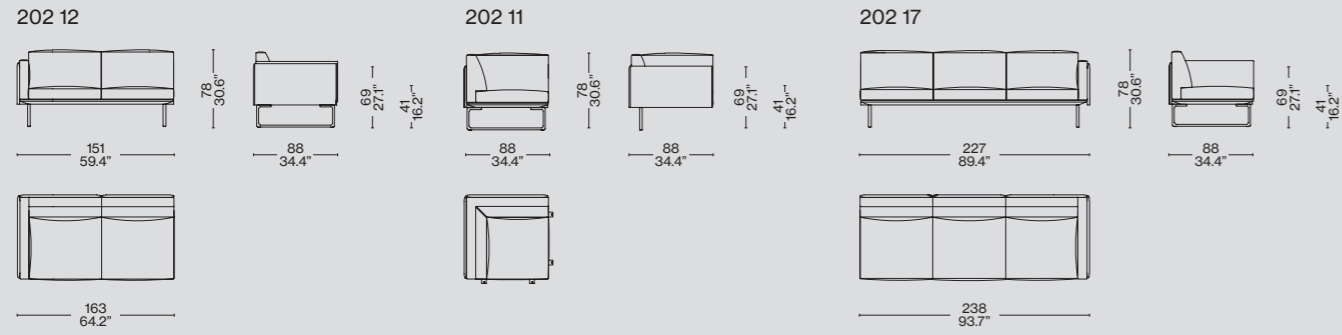

p 44-45

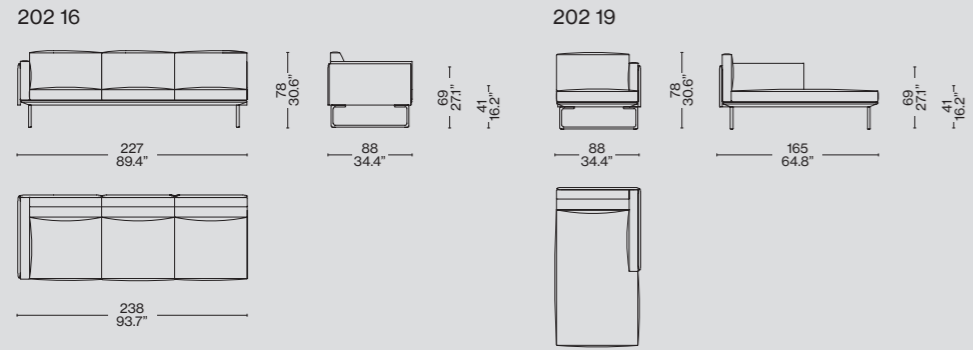

p 37, 48-49, 56, 48

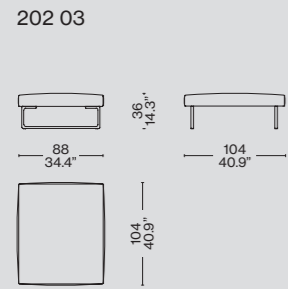

p 48

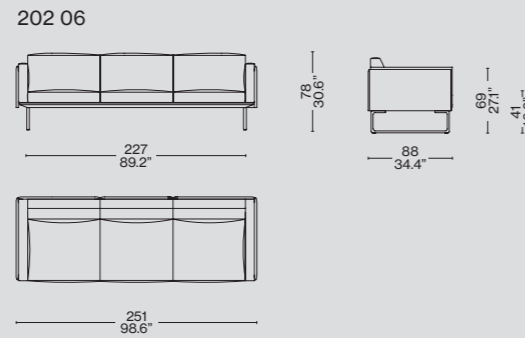

2068 Cube

p 59, 60

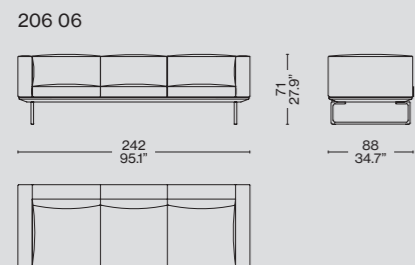

2068 Cube

p 60-61

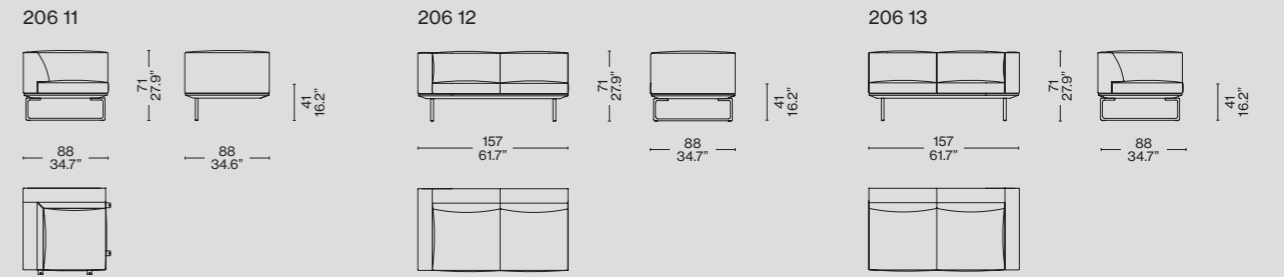

675 Maralunga

p 63, 64-65, 69, 72-73, 78

p 77

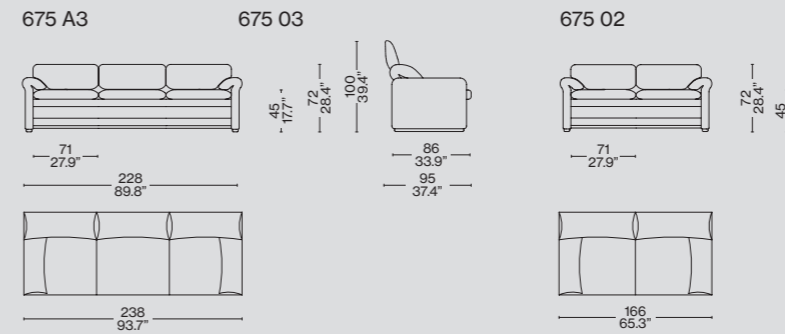

675 Maralunga 40 Maxi

p 81, 84

p 82-83, 85

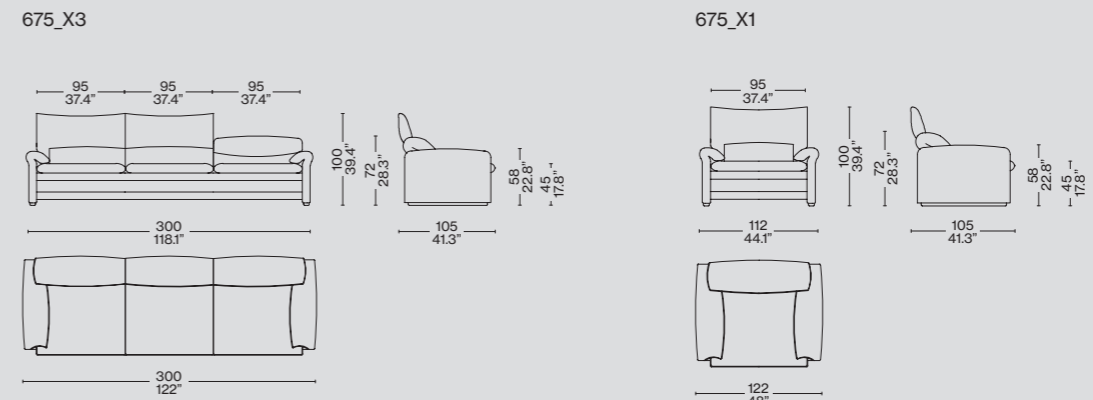

192 Miloe

p 94-95, 102-103, 104-105, 106-107, 110-111, 114-115

192 43

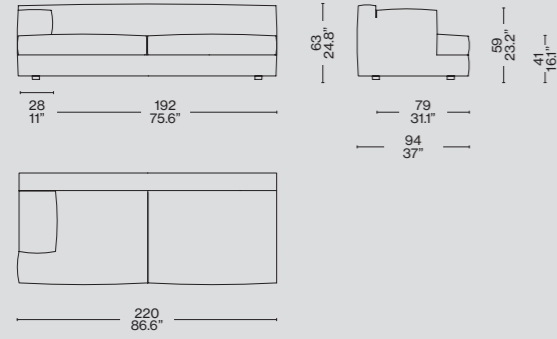

192 30

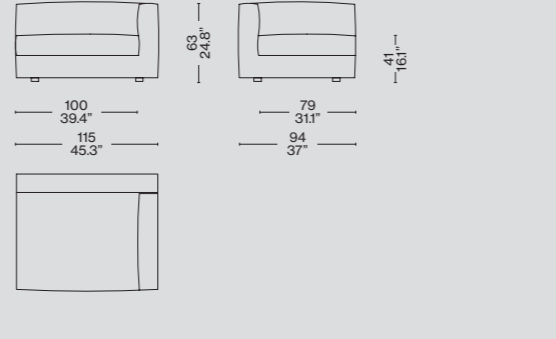

p 91, 92-93

192 71

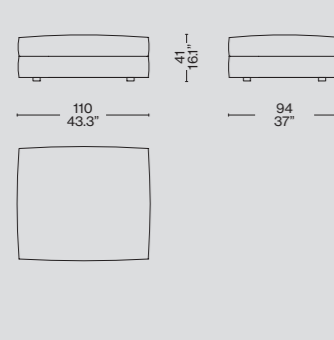

192 43

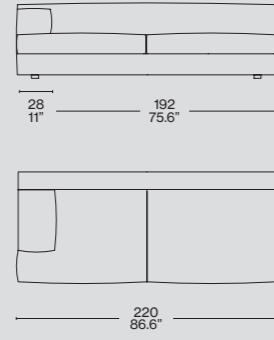

192 30

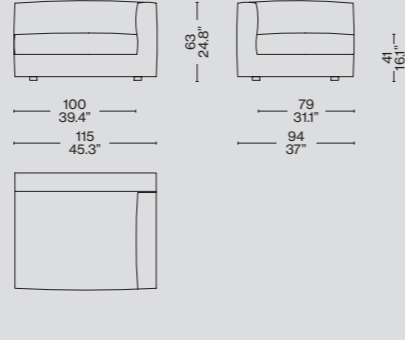

p 94-95, 102-103, 104-105, 106-107, 110-111, 114-115

192 40

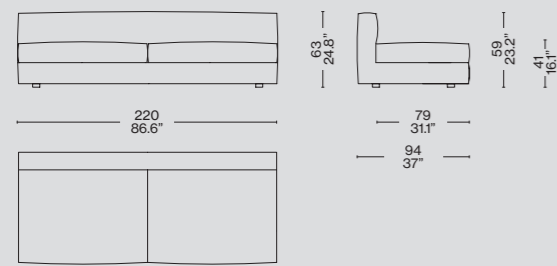

192 71

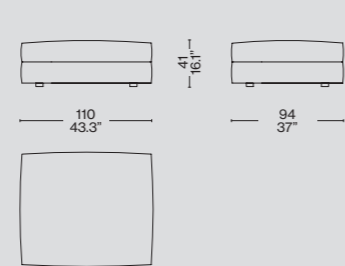

271 Mex Cube

p 117

271 19

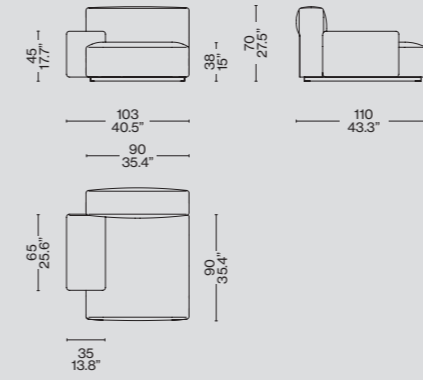

271 51 x 2

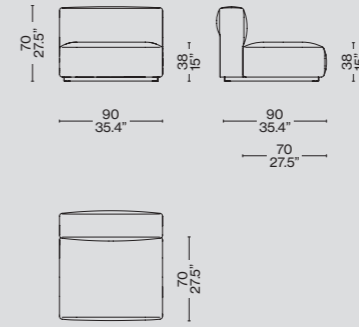

271 18

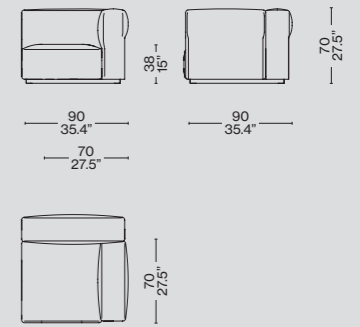

p 118-119, 122-123

271 15

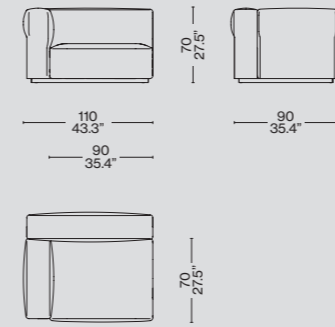

271 51 x 2

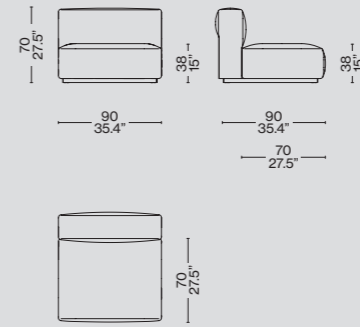

271 20

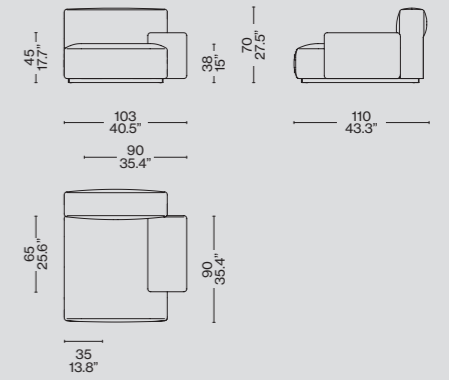

249 Volage EX-S

p 127

249 23

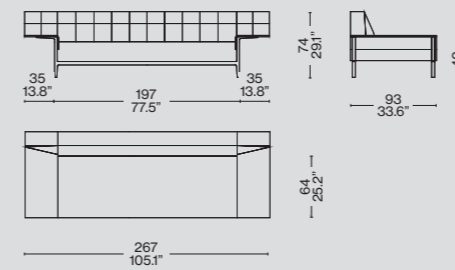

p 128-129

249 21

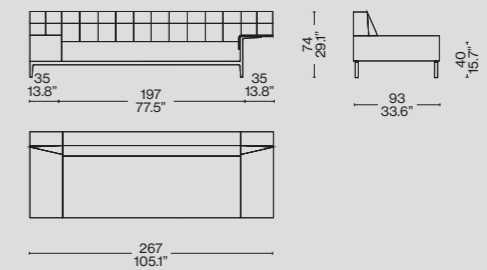

p 132-133, 136-137

249 27

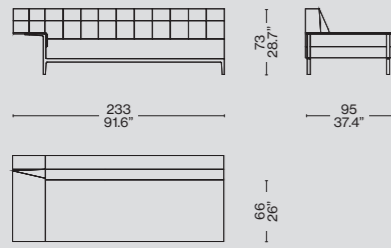

249 33

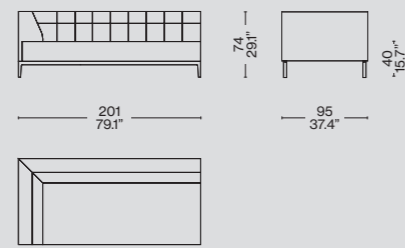

249 29

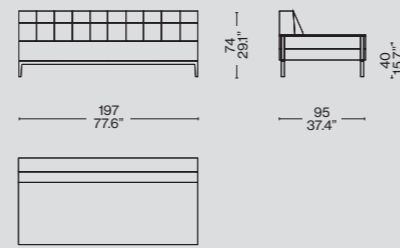

249 62

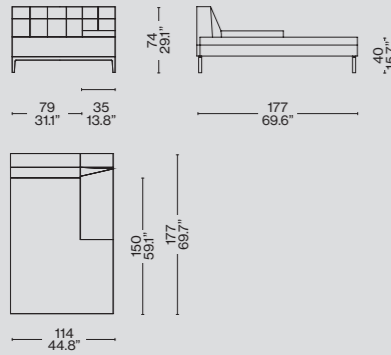

250 Met

p 139, 140-141

250 04

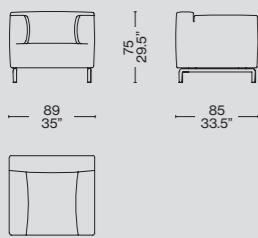

p 140-141

250 07

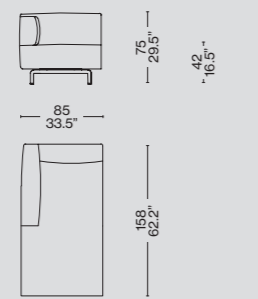

250 54

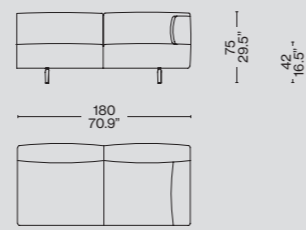

p 144-145

250 10

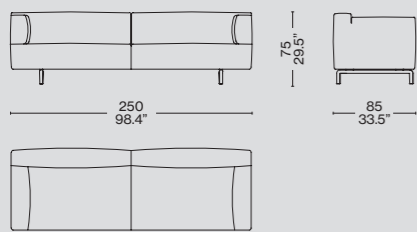

250 00

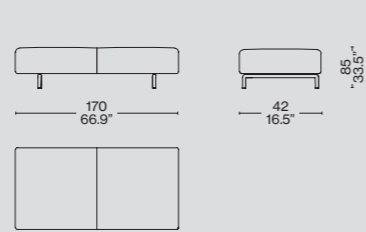

241 Privé

p 149

241 11

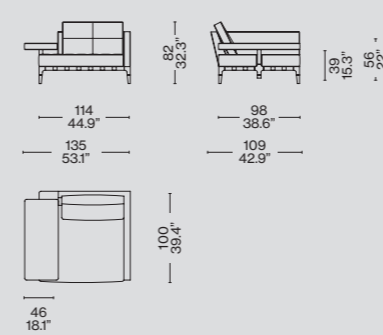

p 150-151

241 63

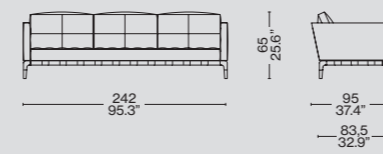

p 153

241 52

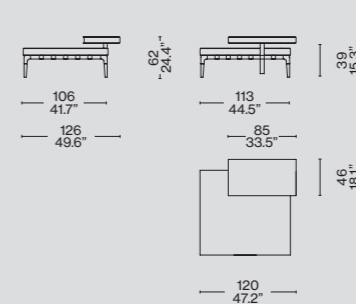

p 152

241 21

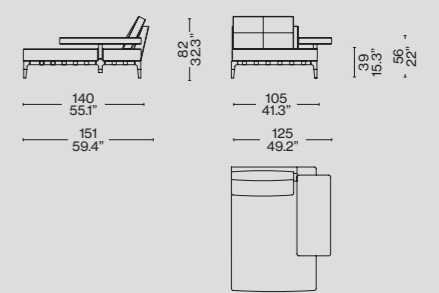

p 154-155

241 31

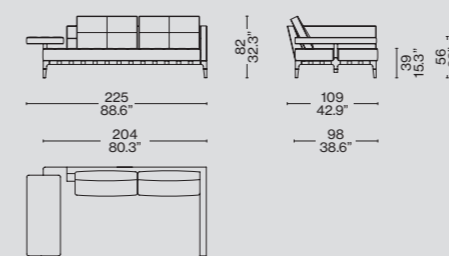

241 00

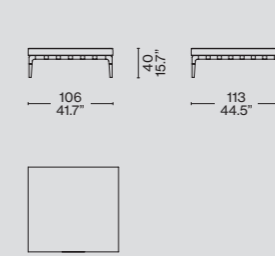

p 158-159

241 41

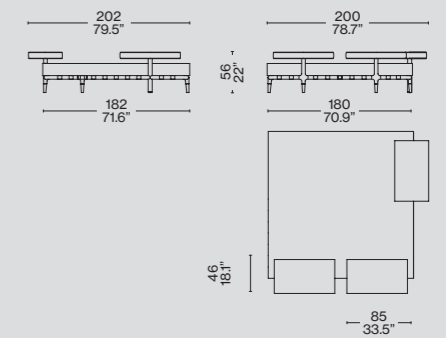

244 Myworld

p 161

244 01 0A

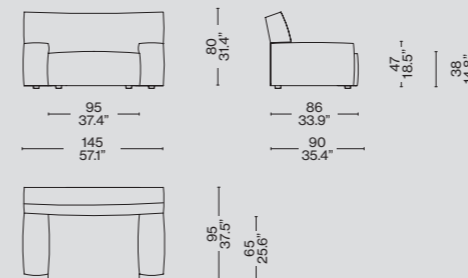

p 162-163

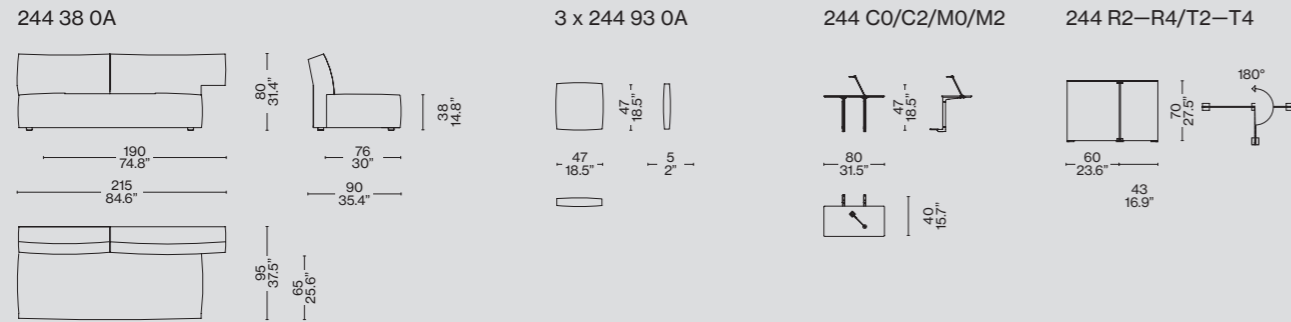
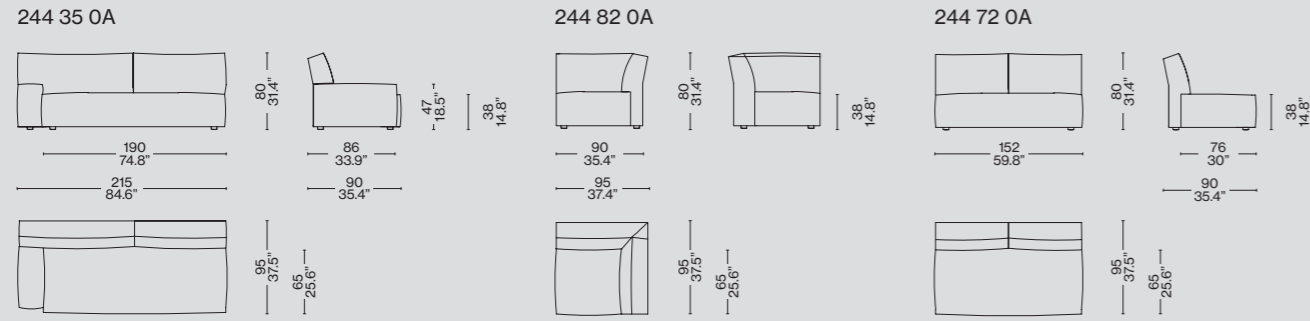

p 168-169

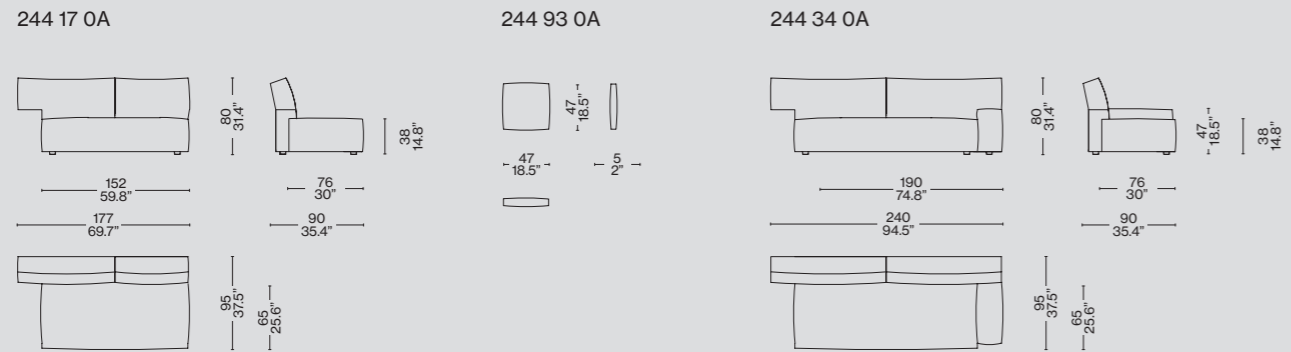

514 Refolo

p 41

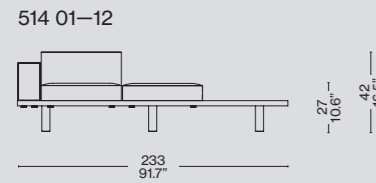

570 Gender

p 26

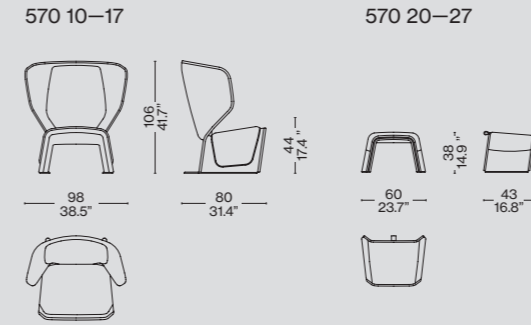

LC4

p 54-55

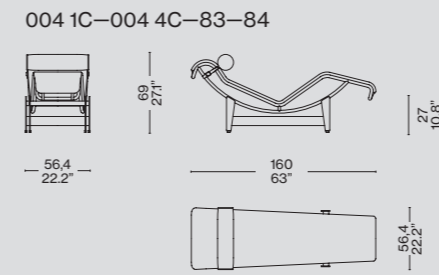

P22

p 112-113

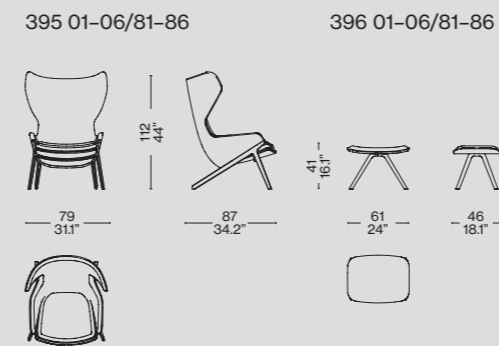

635 Black Red and Blue Zeilmaker version

p

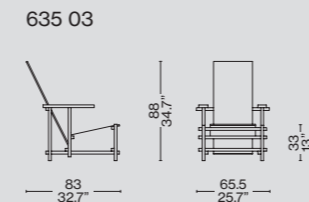

720 Lady

p 30-31

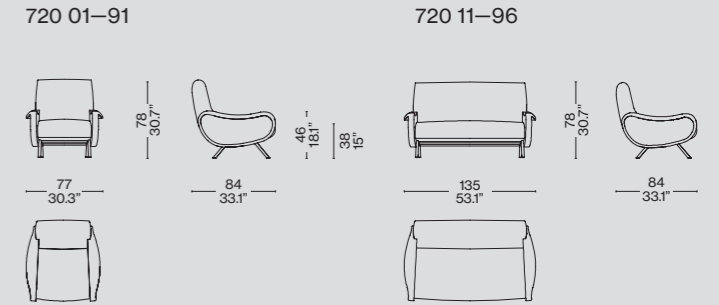

LC2

p 78-79

002 1A-1V/EA-EV

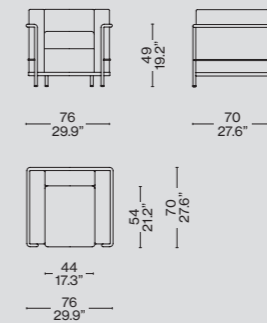

LC3

p 120-121

003 1A-1V/EA-EV

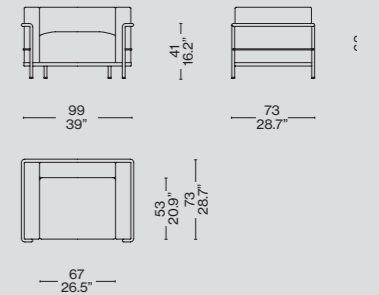

637 Utrecht

p 130-131

637 01/02

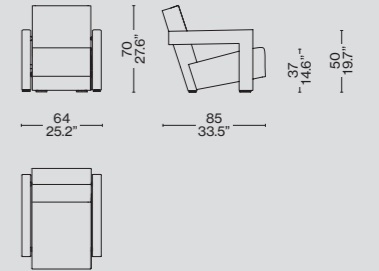

635 Red and Blue

p 142-143

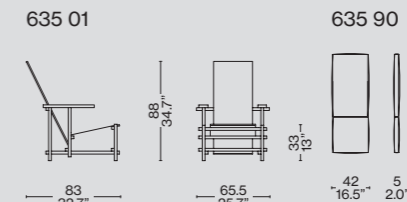

836 Tre Pezzi

p 146-147

836 01-03

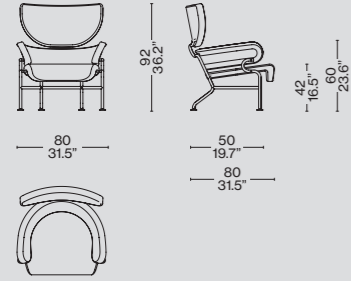

140 Cotone

p 198-199

140 01-07

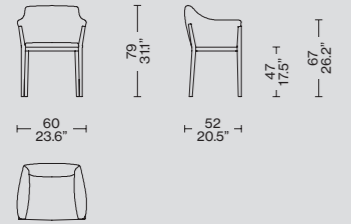

835 Infinito

p 97

835 69/79/89

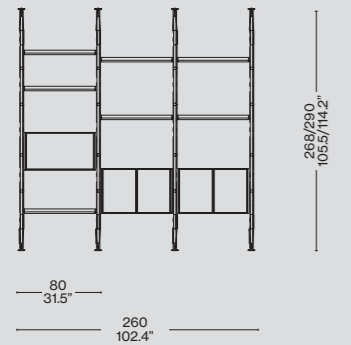

111 Wink

p 164-165

111 01-80

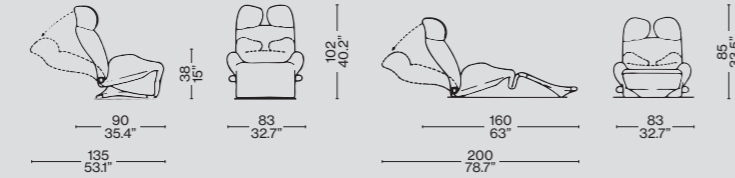

140 Cotone Slim

p 200

140_11-17

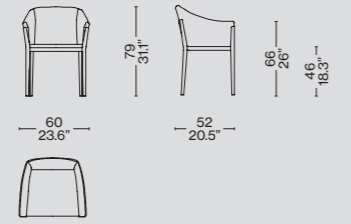

838 Veliero

p 108-109

838 01

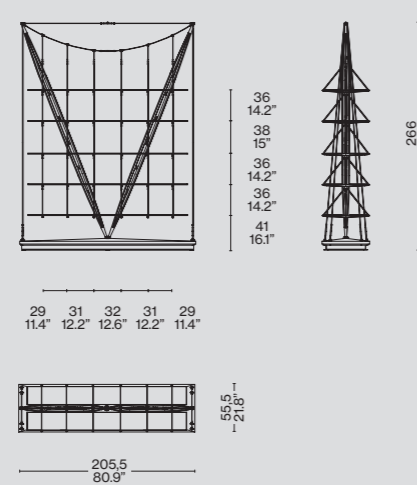

526 Nuage

p 42-43

526 5B-5G

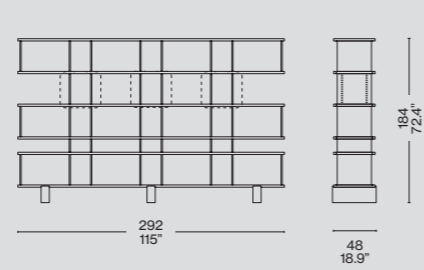

114 Nuvola Rossa

p 166-167

114 01-11

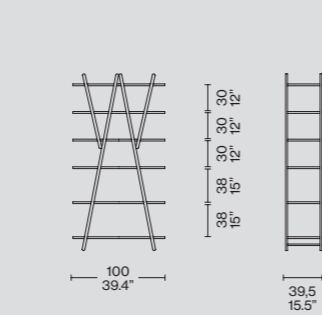

LC20 Casiers Standard

p 66-67

LC20 A3 B3 C3

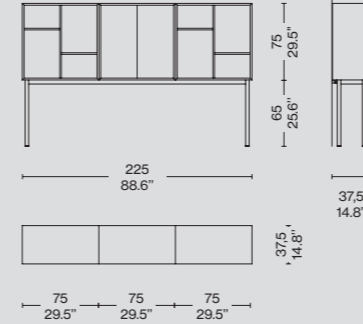

560 Back-Wing

p 86-87

560 10-12

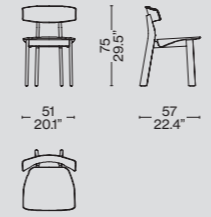

W55 Tulu

p 192-193

W55 11-13

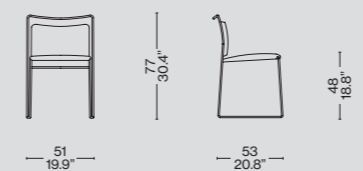

139 Cotone legno

p 201

139 01-07

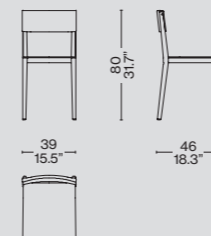

905

p 18-19

905 10/15-20/25

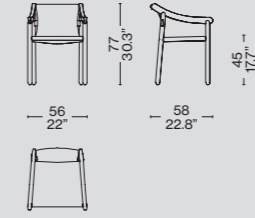

280 Zig Zag

p 156-157

280 10-20

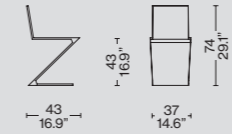

646 Leggera

p 196

646 20-42/30-50

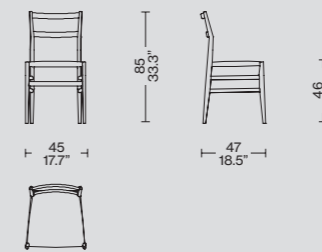

MB8 412 - MB10 413

p 210-211

MB8 412/1A-1S/2A-2S

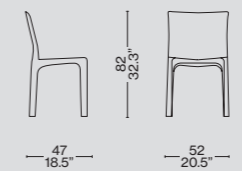

133 Ico

p 34-35

133 10-14 133 90-94

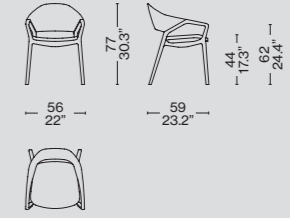

367-369 Hola

p 186-187

367 01

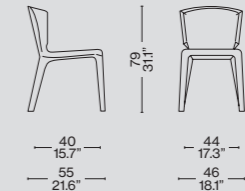

369 01

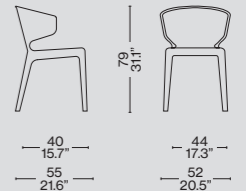

699 Superleggera

p 194-195

699 01-08/11-52

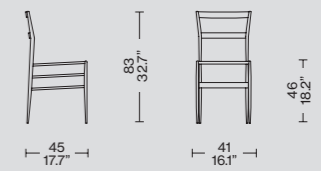

MB10 413/1A-1S/2A-2S

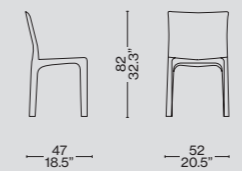

MB10 413/1A-1S/2A-2S

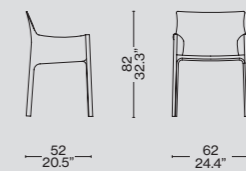

194 9

p 46-47

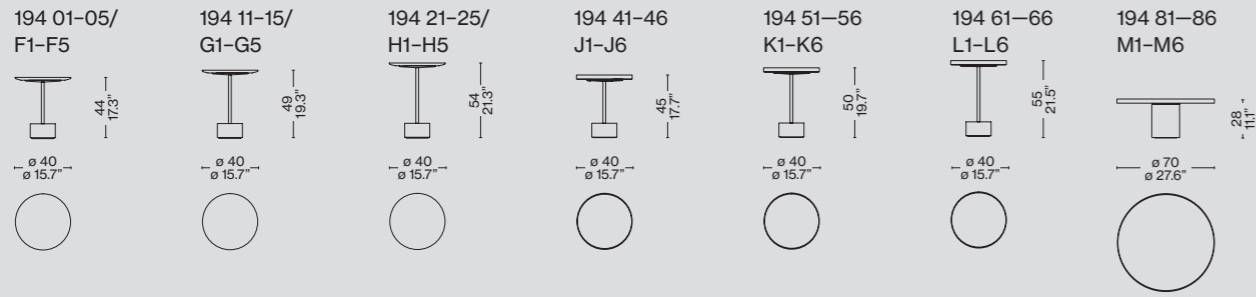

194 A5/A8

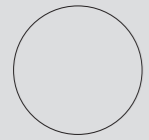

ø 85
ø 33.5"

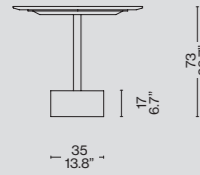

194 B5/B8

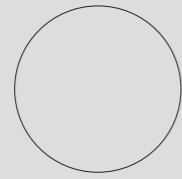

ø 110
ø 43.3"

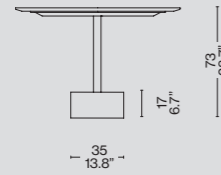

529 Rio

p 70-71

529 01-10

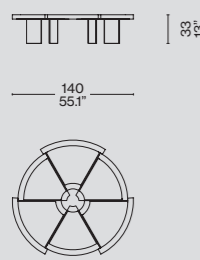

LC10-P

p 74-75

010 4A-4V/9A-9V

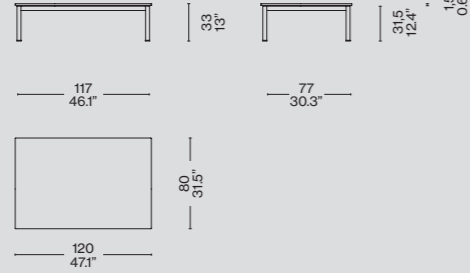

010 2A-2V/7A-7V

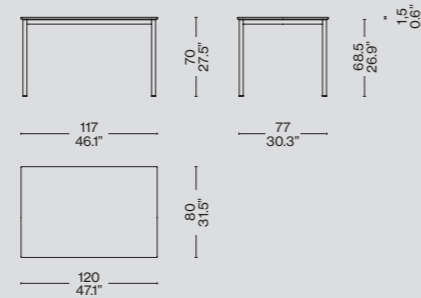

LC14 Tabourets

p 98

Tabouret Cabanon 014 01

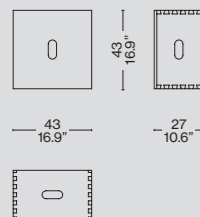

Tabouret Maison du Brésil 014 02

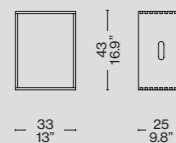

p 99

Tabouret Nantes Rezé 014 LC

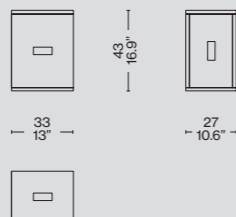

524/523 Tabouret Berger/Méribel

p 96-97

Tabouret Berger 524 01-11



Tabouret Méribel 523 01-11



527 Mexique

p 88-89

527_2

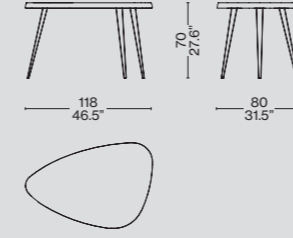

527_16

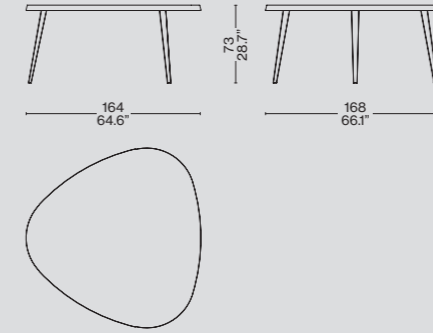

527_18

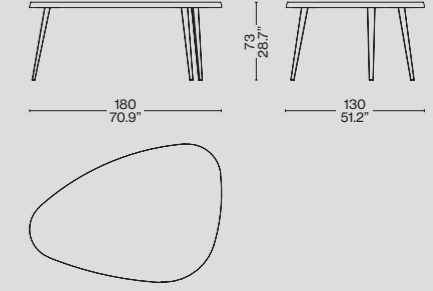

527_1

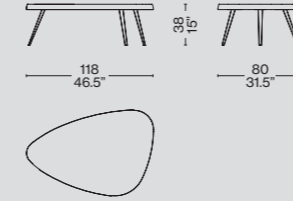

381 Torei

p 124-125

381 11/21/C1/L1

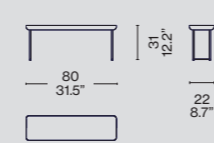

381 12/22/C2/L2

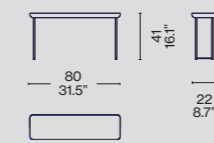

381 13/23/C3/L3

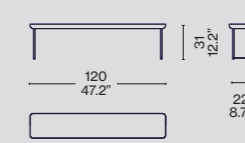

381 14/24/C4/L4

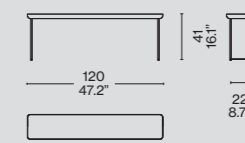

381 81/91/C9/L5

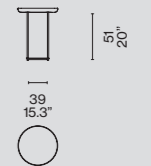

381 41/51/C5/M1/N1/P1/S1/T1/U1

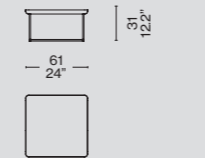

381 42/52/C6/M2/N2/P2/S2/T2/U2

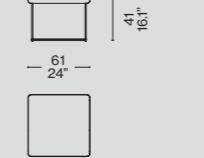

381 43/53/C3/M3/N3/P3/S3/T3/U3

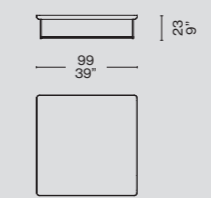

381 44/54

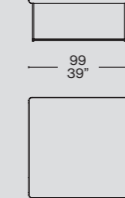

381 61/71/C7

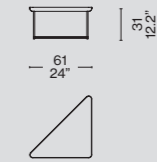

381 62/72/C8

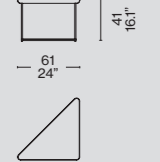

195 Naan

p 183, 184-185

195 01-21-41-A1

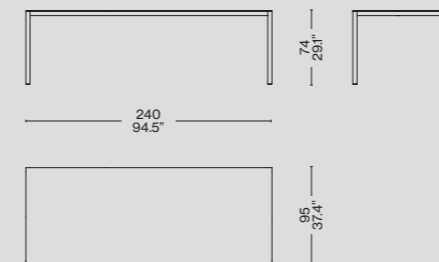

195 02-22-42-A2

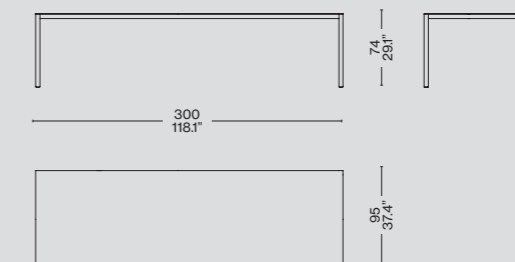

499 Ordinal

p 173, 174-175

499_14

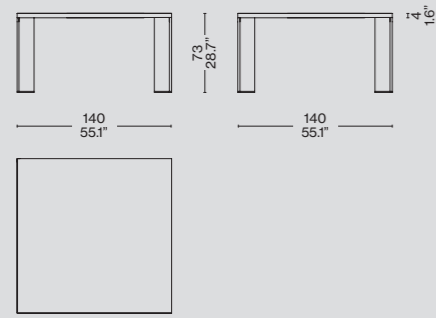

499_16

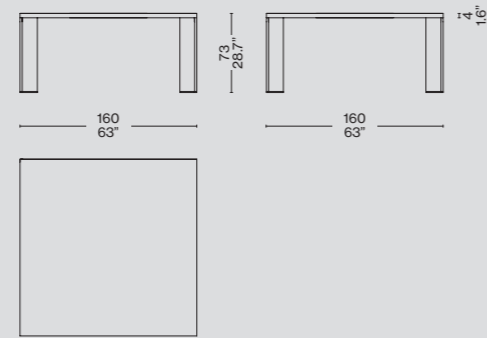

499_23

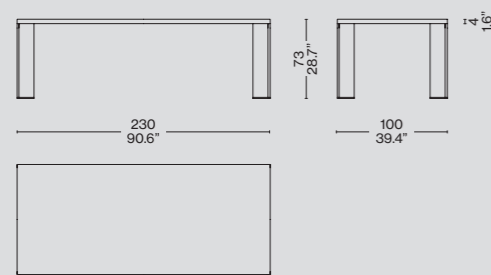

499_24

* solo tavolo in legno massello/solid wood table only

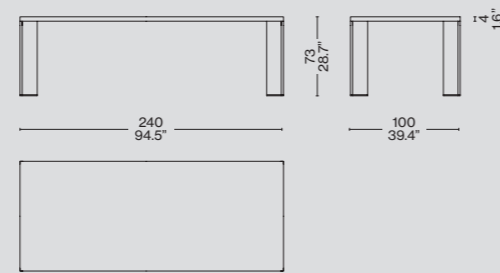

499_28

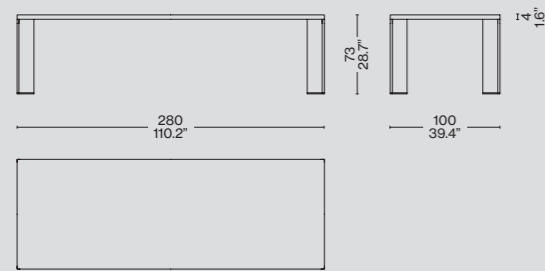

499_26

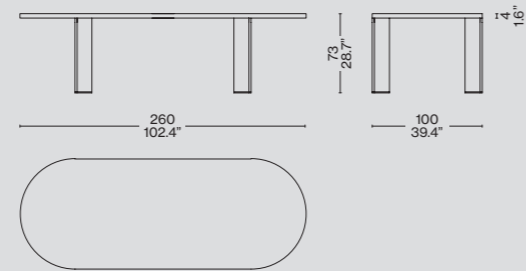

475 Boboli

p 189, 190-191, 194, 199

475-24

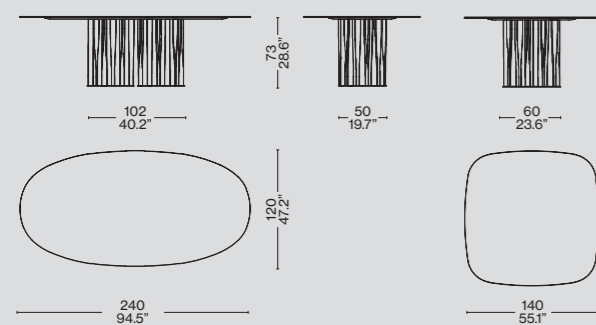

475-14

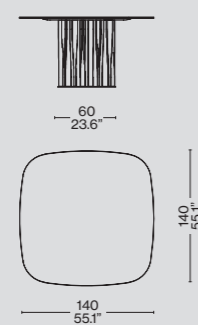

LC6

p 177, 178-179, 180

006 C-V

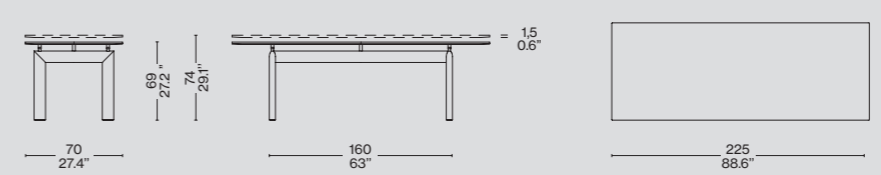

006 M-Q

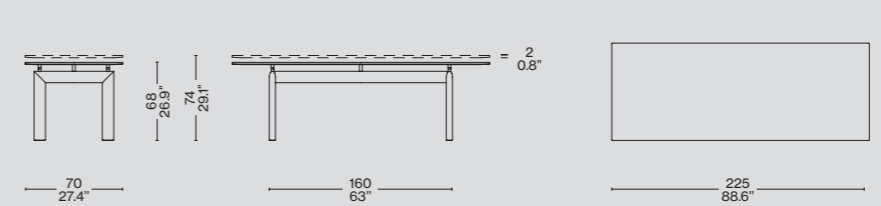

006_X/_Y/_Z

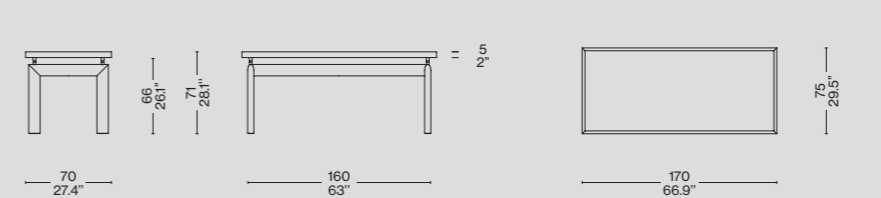

142 Cotone

p 201-203

142_14

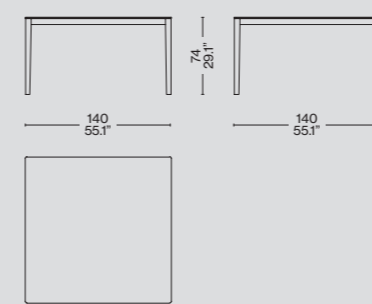

142_16

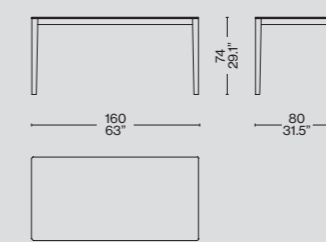

142_20

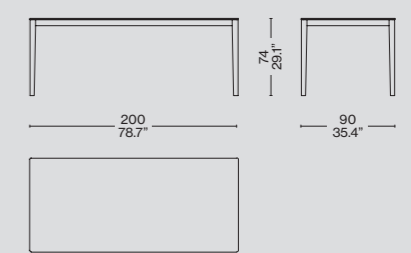

142_28

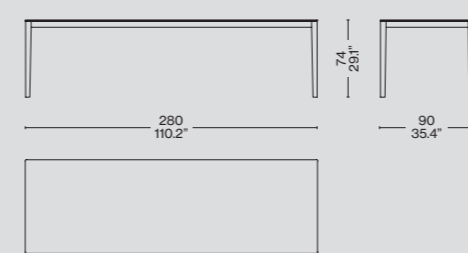

142_24

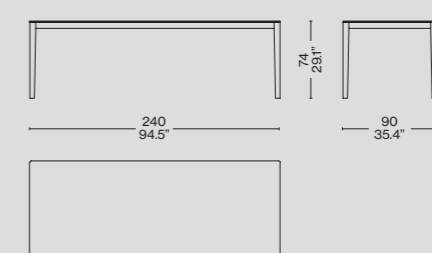

MB5 452 La Rotonda

p 213, 214-215

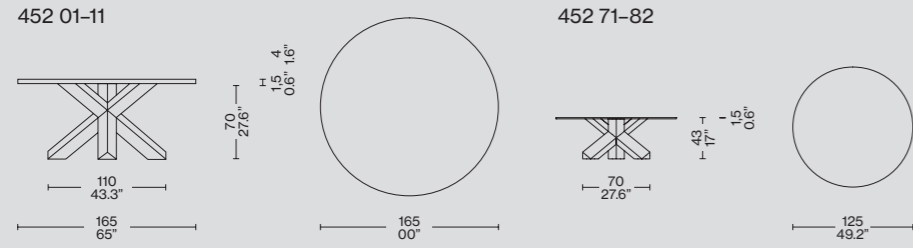

W01 Doge
Cassina Simon Collezione

p 205, 207, 208-209

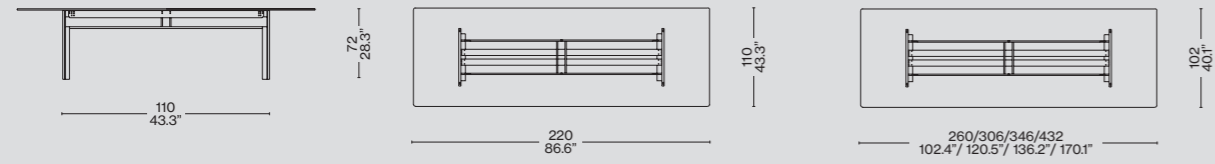

081 Réaction Poétique

p 100-101

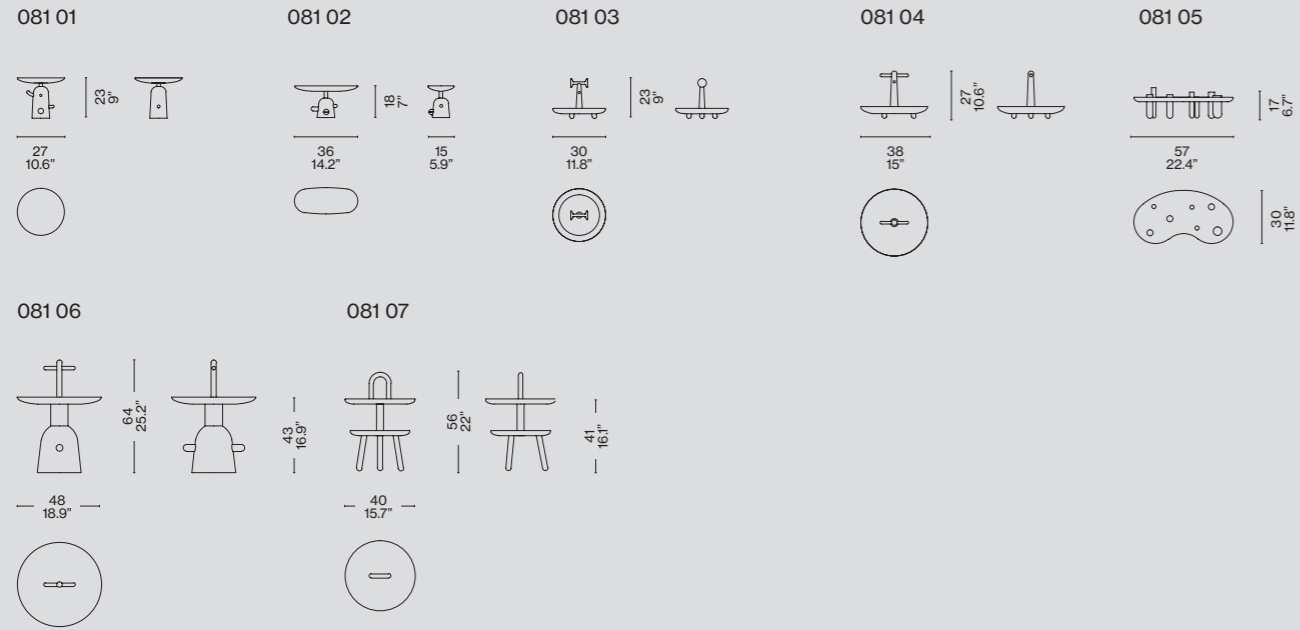

083 Deadline

p 134-135

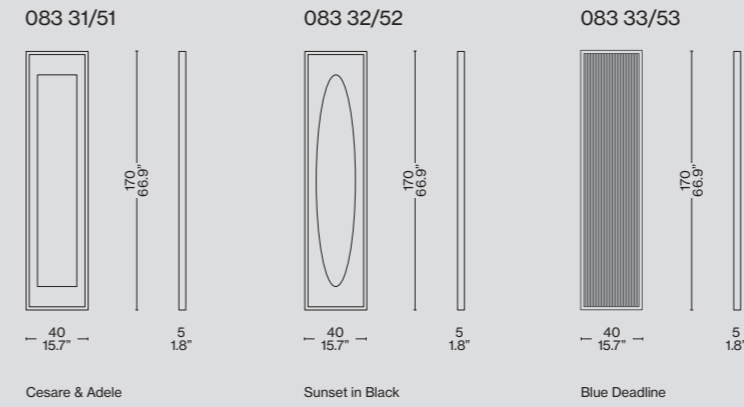
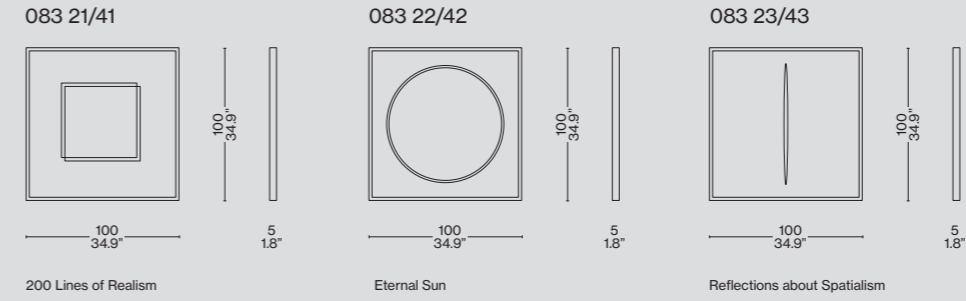
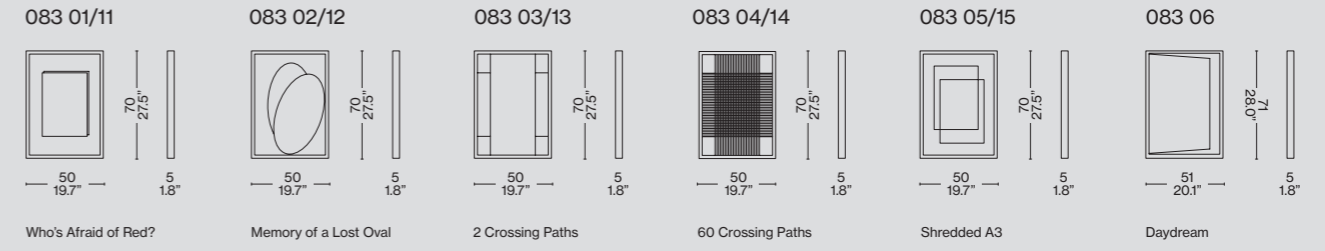

Abaco/Models table

242

Divani/Sofas



Patricia Urquiola
Bow-Sofa
p 14



Patricia Urquiola
Beam Sofa System
p 20



Marco Zanuso
Lady
p 33



Piero Lissoni
8
p 36



Piero Lissoni
8 Cube
p 58



Vico Magistretti
Maralunga
p 62



Vico Magistretti
Maralunga 40 Maxi
p 80



Charlotte Perriand
Refolo
p 40



Piero Lissoni
Miloe
p 90



Piero Lissoni
Mex Cube
p 116



Philippe Starck
Volage EX-S
p 126



Piero Lissoni
Met
p 138



Philippe Starck
Privé
p 148



Philippe Starck
Myworld
p 160



Patricia Urquiola
Gender
p 26



Marco Zanuso
Lady
p 31



LC, PJ, CP
LC4
p 53



LC, PJ, CP
LC2
p 79



Patrick Norguet
P22
p 112



LC, PJ, CP
LC3
p 121



Gerrit Thomas Rietveld
Utrecht
p 130



Gerrit Thomas Rietveld
Red and Blue
p 143



Franco Albini
Tre Pezzi
p 146



Toshiyuki Kita
Wink
p 164



Ronan & Ervan Bouroullec
Cotone
p 198



Ronan & Ervan Bouroullec
Cotone Slim
p 200

The Other Conversation

Sedie/Chairs



Vico Magistretti
905
p 18



Ora-Īto
Ico
p 34



Patricia Urquiola
Back-Wing
p 87



Gerrit Thomas Rietveld
Zig Zag
p 156



Hannes Wettstein
Hola
p 186



Kazuhide Takahama
Cassina Simon Collezione
Tulu
p 193



Gio Ponti
Leggera
p 196



Gio Ponti
Superleggera
p 197



Ronan & Ervan Bouroullec
Cotone legno
p 201



Mario Bellini
Cab
p 211

Tavole tavolini/
Tables and low tables



Piero Lissoni
9
p 46



Charlotte Perriand
Rio
p 71



LC, PJ, CP
LC10-P
p 74



Charlotte Perriand
Mexique
p 88



Charlotte Perriand
T. Berger/Méribel
p 97



Le Corbusier
LC14
p 98



Le Corbusier
LC14 Nantes Rezes
p 99



Luca Nichetto
Torei
p 124



Luca Nichetto
Ordinal
p 172



LC, PJ, CP
LC6
p 176



Piero Lissoni
Naan
p 182



Rodolfo Dordoni
Boboli
p 188



Ronan & Ervan Bouroullec
Cotone
p 198



Mario Bellini
La Rotonda
p 212



Carlo Scarpa
Cassina Simon Collezione
Doge
p 204

Contenitori librerie/Container
units and bookshelves



Charlotte Perriand
Nuage
p 42

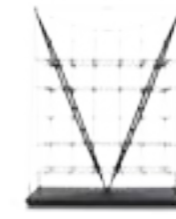

Franco Albini
Veliero
p 57



LC, PJ, CP
Casiers Standard
p 67



Franco Albini
Infinito
p 109



Vico Magistretti
Nuvola Rossa
p 167

Complementi/
Complements

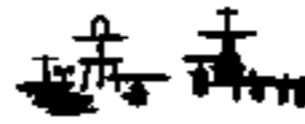

Jamie Hayon
Réaction Poétique
p 100



Ron Gilad
Deadline
p 134

243

Cassina



Cassina S.p.A.
1, Via Busnelli
I - 20821 Meda (MB)
Tel. +39 0362372.1
Fax +39 0362342246
www.cassina.com
info@cassina.it

Art Direction

—

Cassina S.p.A.

Graphic Design

—

Studio FM Milano

Photo

—

Giuseppe Brancato
Santi Caleca
Federico Cedrone
Stefano De Monte
Andrea Ferrari
Nathalie Krag
Nicola Zocchi

Copywriter

—

Giorgia Virzi

Color Selections

—

Pan Group

Printed in Italy by

—

O.G.M. VII.2018

Copyright©Cassina
S.p.A. 2018
All rights reserved