

FIAM

Re-Shoot 2023

Indice prodotti

Product index

SPECCHI | MIRRORS



phantom

design Helidon Xhixha
& Dante O. Benini Luca Gonzo

04

TAVOLI | TABLES



crystaline

design Marcel Wanders studio

12



agos

design Ludovica + Roberto Palomba

26



luxor

design Rodolfo Dordoni

34

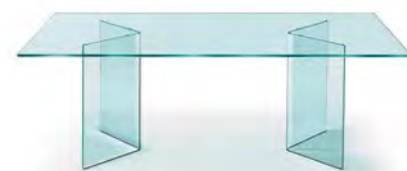

corner

design CRS Fiam

44

TAVOLI BASSI | COFFEE TABLES



rialto

design CRS Fiam

48

CONSOLLE | CONSOLES



elementare

design Enrico Tonucci

50



charlotte

design Prospero Rasulo

52

VETRINE | SHOWCASES



palladio

design Vittorio Livi

54



inori

design Setsu & Shinobu Ito

58

schede tecniche
technical data

76

Fiam, garanzia di qualità
Fiam, guarantee of quality

100

Moodbook 2023
catalogue



phantom

design Helidon Xhixha & Dante O. Benini - Luca Gonzo

Specchio da terra o da parete in vetro fuso da 6 mm retro argentato, specchio piano da 5 mm. Telaio posteriore in metallo verniciato. Possibilità di appendimento verticale od orizzontale.

Free-standing or hanging mirror in 6 mm high temperature melted glass, back-silvered. 5 mm flat mirror. Rear frame in painted metal. It can be hung horizontally or vertically.

Miroir appuyant au mur et accrochable en verre en fusion de 6 mm argenté, miroir plat de 5 mm. Cadre arrière en métal verni. Possibilité d'accrochage en horizontal ou en vertical.

Stand- bzw. Wandspiegel aus geschmolzenem Glas versilbert. Flacher Spiegel 5 mm stark. Hinterer Rahmen aus lackiertem Metall. Kann vertikal und horizontal aufgehängt werden.



Specchio rettangolare da terra.
Free-standing rectangular mirror.
190 x 15 x 90 cm
76 3/4" x 5 7/8" x 35 7/16"
Divano Carrara, tavolino Coral Beach, tavolino Cannage.
Carrara sofa, Coral Beach coffee table, Cannage coffee table.

Specchio rettangolare da terra.
Free-standing rectangular mirror.
190 x 15 x 90 cm
76 3/4" x 5 7/8" x 35 7/16"

[BACK TO INDEX](#)





Specchio rettangolare da terra.
Free-standing rectangular mirror.
198 x 18 x 98 cm
78" x 7" x 38 9/16"
Tavolini Lakes, divano Carrara.
Lakes coffee tables, Carrara sofa.

cristaline

design Marcel Wanders studio

Tavolo con piano in vetro extralight da 15 mm fuso a gran fuoco e temperato, disponibile trasparente o retroverniciato con tinte metallizzate. Base in metallo finitura Titanio opaco oppure Nichel Nero lucido. Il piano è disponibile anche in vetro extralight da 15 mm temperato, oppure in vetro bronzo o fumè da 16 mm stratificato e bisellato.

Table with top in 15 mm fused and tempered extralight glass, available transparent or back-lacquered with metallic paints. Metal base available in opaque Titanium or in Black Glossy Nickel finishes. The top is available also in 15 mm tempered extralight glass, or in 16 mm bronze or smoked glass, layered and bevelled.

Table avec plateau en verre extra light de 15 mm en fusion et trempé, disponible transparent ou vernie dessous avec des teintes métallisées. Base en métal, finition Titane opaque ou Nickel noir brillant. Le plateau est disponible aussi en verre extra light de 15 mm trempé ou en verre bronze ou fumé de 16 mm feuilleté et biseauté.

Tisch mit platte aus 15 mm geschmolzenem und gehärtetem extralight Glas, transparent oder unterlackiert mit metallischen Farben erhältlich. Untergestell aus Metall in den folgenden Farbvarianten: Matt Titan oder Glanz Schwarz Nickel. Die Platte ist in den folgenden Varianten erhältlich: - 15 mm extralight gehärtetes Glas oder 16 mm geschichtete Bronze- bzw Rauchglas.

Base in metallo finitura nichel nero lucido
Piano in vetro extralight fuso.

Black Glossy Nickel finish metal base,
Fused extralight glass top.

300 x 110 x 75 cm
118 1/8" x 43 5/16" x 29 1/2"





Base in metallo finitura nichel nero lucido
Piano in vetro extralight fuso.

Black Glossy Nickel finish metal base,
Fused extralight glass top.

300 x 110 x 75 cm
118 1/8" x 43 5/16" x 29 1/2"

Poltroncine Oscar, vetrine Aura, lampada Pearl.
Oscar chairs, Aura showcases, Pearl lamp.





Base in metallo finitura nichel nero lucido
Piano in vetro extralight fuso.
Black Glossy Nickel finish metal base,
Fused extralight glass top.
300 x 110 x 75 cm
118 1/8" x 43 5/16" x 29 1/2"
Sedie Oscar, specchio Silica.
Oscar chairs, Silica mirror.



Base in metallo finitura Titanio opaco,
Piano in vetro extralight liscio.
Opaque Titanium finish metal base,
Extralight flat glass top.
300 x 110 x 75 cm
118 1/8" x 43 5/16" x 29 1/2"
Sedie Callas, vetrine Echo,
lampada Pearl, libreria Inori.
Callas chairs, Echo showcases,
Pearl lamp, Inori bookcase.

Base in metallo finitura Titanio Opaco,
Piano in vetro extralight fuso retroverniciato Marrone Brillante.
Opaque Titanium finish metal base,
Fused extralight glass top, Brilliant Brown back-painted.
Libreria Inori.
Inori bookcase.





Base in metallo finitura Titanio Opaco,
Piano in vetro extralight fuso retroverniciato Marrone Brillante.
Opaque Titanium finish metal base,
Fused extralight glass top, Brilliant Brown back-painted.
300 x 110 x 75 cm
118 1/8" x 43 5/16" x 29 1/2"
Sedie Callas, libreria Inori.
Callas chairs, Inori bookcase.

[BACK TO INDEX](#)



agos

design Ludovica + Roberto Palomba

Agos nasce dalla volontà di realizzare una collezione di tavoli caratterizzati da un design raffinato ed al contempo rassicurante. Per la base abbiamo immaginato un vero e proprio schema architettonico che collega i piedi della struttura creando un sistema di linee che intersecano fra loro dando vita ad un gioco prospettico davvero interessante. La struttura è in acciaio verniciato, collegata da traverse a sostenere i piani in vetro trasparente in varie forme.

Agos was born out of the willingness to create a collection of tables characterized by a polished yet reassuring design. For the base we imagined an out-and-out architectural scheme that connects the feet of the structure, creating a system of lines that intersect each other and result in a very interesting perspective play. The structure is made of painted steel, connected by crossbars to support the transparent glass tops in various shapes.

Agos est née du désir de créer une collection de tables caractérisées par un design raffiné mais rassurant. Pour la base, nous avons imaginé un véritable schéma architectural qui relie les pieds de la structure, en créant un système de lignes qui se croisent pour créer un jeu de perspective vraiment intéressant. La structure est en acier verni, reliée par des traverses pour soutenir les plateaux en verre transparent de différentes formes.

Agos ist aus dem Willen entstanden, eine Kollektion von Tischen zu schaffen, die sich durch ein raffiniertes und beruhigendes Design. Für die Basis haben wir uns ein regelrecht architektonisches Schema ausgedacht, das die Füße der Struktur miteinander verbindet und ein System von Linien schafft, die sich gegenseitig schneiden und ein sehr interessantes Perspektivenspiel ergeben. Die Struktur besteht aus lackierendem Stahl, die durch Querbalken verbunden ist, der die transparente Glasfläche in verschiedenen Formen lagert.

Base in metallo finitura Grigio Lava,
Piano in vetro fuso retroverniciato, finitura Nero Brillante.

Lava Grey finish metal base,
Fused and back-painted glass top, Brilliant Black finish.

300 x 110 x 75 cm
118 1/8" x 43 5/16" x 29 1/2"

Poltroncine **Newton**, libreria **Inori**, lampada **Pearl**.
Newton chairs, **Inori** bookshelf, **Pearl** lamp.





Piano in vetro fuso retroverniciato,
finitura Nero Brillante.
Fused and back-painted glass top,
Brilliant Black finish.

Base in metallo finitura Greige Metallizzato, piano in vetro bronzo.
Metallic Greige finish metal base, bronze glass top.

ø160 x 75 cm
ø63" x 29 1/2"

Sedie Callas, lampada Marry Me.
Callas chairs, Marry Me lamp.





luxor

design Rodolfo Dordoni

Tavolo con piano in vetro fumé o bronzo stratificato da 8+8 mm finitura filo lucido tondo, disponibile anche in vetro temperato trasparente o extralight. A seconda della misura e della configurazione desiderata base composta da 2, 3 o 4 cilindri (Ø 40 cm) in vetro da 10 mm, disponibile fumé, bronzo trasparente o extralight. Disponibile anche con piani a misura.

Dining table with layered glass top 8+8 mm-thick brilliant polished rim, in smoked or bronze glass also available in tempered glass, transparent or extralight. 10 mm-thick curved glass base, composed of 2, 3 or 4 cylinders (Ø 40 cm) depending upon the size and the shape requested. Bases are available in smoked glass, bronze glass, transparent glass or extralight glass. Custom size top available on request.

Table avec plateau en verre feuilleté de 8+8 mm fumé ou bronze finition chant poli arrondi, ou en verre trempé transparent ou extralight. Base en verre cintré de 10 mm se composant de 2, 3 ou 4 cylindres (Ø 40 cm) dépendant de la mesure ou de la configuration désirée. Disponible en verre fumé, en verre bronze, en verre transparent ou en verre extralight. La table Luxor est également disponible avec le plateau sur mesure.

Tisch mit 8+8+ mm-starker Schichtglasplatte in Rauch- oder Bronze-Glas oder in transparentem bzw. extralight gehärtetem Glas. Untergestell bestehend aus 2, 3 bzw. 4 Zylindern (Durchmesser 40 cm) abhängig von den gewünschten Massen und Gestaltung, aus 10 mm-starkem gebogenem Glas, lieferbar in den Ausführungen Rauchglas, oder Bronzeglas, transparentes bzw. extralight Glas. Auch mit maßgefertigter Platte lieferbar.

Tavolo tondo in vetro bronzo.
Round table in bronze glass.



Tavolo tondo in vetro bronzo.
Round table in bronze glass.
ø 160 x 75 cm
ø 63" x 29 1/2"
Poltroncine Oscar, libreria Inori.
Oscar chairs, Inori bookcase.



(photo p.38-39)
Tavolo rettangolare in vetro bronzo.
Rectangular table in bronze glass.
300 x 110 x 75 cm
118 1/8" x 43 5/16" x 29 1/2"
Poltroncine **Newton**, libreria **Remind**.
Newton chairs, **Remind** bookcase.





Tavolo rettangolare in vetro fumè.
Rectangular table in smoked glass.
300 x 110 x 75 cm
118 1/8" x 43 5/16" x 29 1/2"

Poltroncine **Newton**, specchio **Caadre**.
Newton chairs, **Caadre** mirror.

[BACK TO INDEX](#)

corner

design CRS Fiam

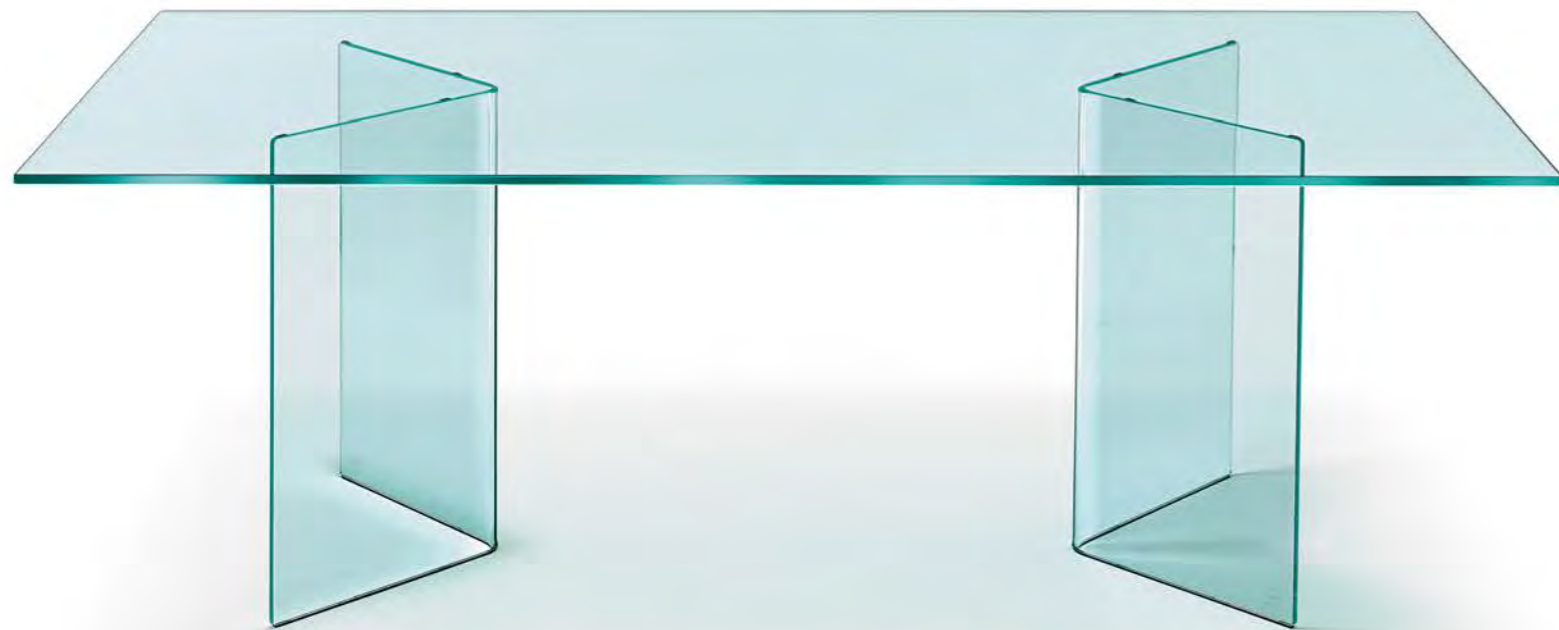

Tavolo composto da basi
in vetro curvato da 12 mm
con lati da 45 cm e piano
in vetro da 15 mm temperato.

Table with 12 mm-thick curved
glass base (sides 45 cm) and
15 mm-thick tempered glass top.

Table avec piètement en verre
cintré de 12 mm, côtés
de 45 cm. Plateau en verre
trempe de 15 mm.

Tisch mit Untergestell
aus 12 mm-starkem gebogenem
Glas mit Winkeln von 45 cm.
Gehärtete Glasplatte,
Stärke 15 mm.

Tavolo rettangolare.
Rectangular table.
180 x 90 x 73 cm
70 7/8" x 35 7/16" x 28 3/4"



Tavolo rettangolare in vetro bronzo.
Rectangular table in brozne glass.
300 x 110 x 75 cm
118 1/8" x 43 5/16" x 29 1/2"

Poltroncine **Newton**, specchi **Shift**, libreria **Inori**.
Newton chairs, **Shift** mirrors, **Inori** bookcase.

rialto

design CRS Fiam



Tavolo basso in vetro curvato.
Disponibile anche su misura.

Coffee table in curved glass.
Also available on customized size.

Table basse en verre cintré.
Egalement disponible sur mesure.

Couchtisch aus gebogenem Glas.
Auch als Maßanfertigung lieferbar.

Tavolino in vetro extralight.
Extralight glass coffee table.
120 x 60 x 32 cm
47 1/4" x 23 5/8" x 12 5/8"

elementare

design Enrico Tonucci

Consolle in vetro curvato da 12 mm. Disponibile anche con ripiano in vetro da 10 mm e in vetro extralight.

Console in 12 mm-thick curved glass. Also available with 10 mm-thick glass shelf and in extralight glass.

Console en verre cintré de 12 mm. Disponible aussi avec étagère en verre de 10 mm et en verre extralight.

Konsole aus 12 mm-starkem gebogenem Glas. Auch mit Fachboden aus 10 mm-starkem Glas und aus extralight Glas lieferbar.

Consolle in vetro extralight, con ripiano. Extralight glass console, with shelf.

120 x 36 x 76 cm
47 1/4" x 14 3/16" x 29 5/16"





charlotte

design Prospero Rasulo

Consolle in vetro curvato da 15 mm. Disponibile anche con ripiano in vetro curvato acidato da 6 mm.

Console in 15 mm-thick curved glass. Also available with 10 mm-thick acid etched glass shelf.

Console en verre cintré de 15 mm. Disponible aussi avec étagère en verre cintré depoli de 6 mm.

Konsole aus 15 mm-starkem gebogenem Glas. Auf Wunsch: gebogener Fachboden aus geätztem 6 mm-starkem Glas.

Consolle in vetro extralight, con ripiano.
Extralight glass console, with shelf.
112 x 36 x 80 cm
44 1/8" x 14 3/16" x 31"

palladio

design Vittorio Livi



Vetrina elettrificata in vetro curvato da 6 mm con quattro ripiani fissi in vetro da 6 mm (L 58 cm, P 31 cm) e top in vetro da 12 mm. Profili in alluminio finitura brill spazzolato. Anta con serratura. Corpo illuminante (optional) posizionabile anche sotto il top.

Wired showcase in 6 mm-thick curved glass, with four 6 mm-thick glass shelves (L 58 cm, W 31 cm), 12 mm thick glass top, door with lock. Profiles in brushed aluminium glossy finish. The optional lights can also be placed under the top.

Vitrine électrifiée en verre cintré de 6 mm avec quatre étagères fixes en verre de 6 mm, top en verre de 12 mm, porte avec serrure. Profils en aluminium brossé finition brillante. Les projecteurs peuvent être positionnés aussi sous le plateau.

Vitrine aus 6 mm-starkem gebogenem Glas mit vier festen Fachböden aus 6 mm-starkem Glas. Ausgerüstet für eine Beleuchtung. Top aus 12 mm-starkem Glas. Profile aus gebürstetem glänzendem Aluminium Tür mit Schloss. Die Beleuchtung kann auch unter das Top angebracht werden.

Vetrina in vetro trasparente, base in vetro extralight retroargentato.

Showcase in transparent glass, back-silvered extralight glass base.

64 x 37 x 166 cm
25 ³/₁₆" x 14 ⁹/₁₆" x 65 ³/₈"

Vetrina in vetro trasparente,
base in vetro extralight retroargentato.
Showcase in transparent glass,
back-silvered extralight glass base.
64 x 37 x 166 cm
25 ³/₁₆" x 14 ⁹/₁₆" x 65 ³/₈"

[BACK TO INDEX](#)



inori

design Setsu & Shinobu Ito

Sistema composto da elementi in vetro o legno modulari. La modularità e versatilità ne permette l'utilizzo come libreria, espositore, contenitore, porta Tv.

Il sistema si sviluppa anche in situazione autoportanti (inori freestanding): nelle versioni in vetro e nella misura larga cm 240, da altezza minima 135 cm sino all'altezza massima 180 cm il sistema prevede delle barre di irrigidimento in alluminio anodizzato nero.

Basi in vetro fumè retroverniciato nero, ripiani in vetro extralight, montanti in vetro extralight H 42cm.

Black back-painted smoked glass bases, Extralight glass shelves, Extralight glass uprights, H 42cm.

Composizione lineare: 240 x 36,5 x 221 cm (per ogni sistema).

Linear composition: 94 1/2" x 14 3/8" x 87" (each system).

System consisting of modular glass or wood elements. Its modularity and versatility allow it to be used as a bookcase, display case, storage unit or TV unit.

The system can also be used to construct free-standing compositions (inori freestanding): in glass versions and in width 240 cm, from a height of minimum 135 cm up to the maximum height of 180 cm the system is complete with black anodised aluminium reinforcement bars.

Système composé d'éléments modulaires en verre ou bois. Sa modularité et sa polyvalence permettent de l'utiliser comme une bibliothèque, un présentoir, un meuble de rangement, un meuble TV.

Possibilità di système autoporteur (inori freestanding): dans les versions en verre et dans la largeur de 240 cm, d'une hauteur minimale de 135 cm jusqu'à une hauteur maximale de 180 cm, le système est doté de barres d'armature en aluminium anodisé noir.

System aus modularen Glas- oder Holz-Elementen. Vielseitig einsetzbar und beliebig kombinierbar, als Bücherregal, Ausstellungsregal, TV-Element usw.

Auch freistehend als Raumteiler (inori freestanding) (aus Glas Breite 240 cm, Höhe mindestens 135 cm, maximal 180 cm, mit Verstärkungen aus Schwarz eloxiertem Aluminium).





Basi e ripiani in noce termotrattato nero, montanti in vetro fumè H 42cm.
 Heat-treated black finish walnut base and shelves, smoked glass uprights H 42cm.
 Composizione lineare:
 240 x 37,5 x 281 cm (per ogni sistema).
 Linear composition:
 94 1/2" x 14 3/4" x 110 5/8" (each system).

[BACK TO INDEX](#)





Basi e ripiani in noce canaletto finitura Tabacco, montanti in vetro bronzo H 42cm.
Tobacco finish Canaletto walnut base and shelves, bronze glass uprights, H 42cm.
Composizione lineare:
240 x 37,5 x 281 cm (per ogni sistema).
Linear composition:
94 1/2" x 14 3/4" x 110 5/8" (each system).

[BACK TO INDEX](#)





Base e piano superiore in noce canaletto finitura Tabacco, montanti in vetro bronzo H 42cm.

Tobacco finish Canaletto walnut base and top, bronze glass uprights, H 42cm.

Composizione lineare: 240 x 37,5 x 51 cm.

Linear composition: 94 1/2" x 14 3/4" x 20".





Base e ripiani in legno Rovere "Old",
montanti in vetro extralight, H42 cm.

"Old Style" oak base and shelves;
extralight glass uprights, H 42 cm.

Composizione lineare:
180 x 37,5 x 189 cm (per ogni sistema).

Linear composition:
70 ⁷/₈" x 14 ³/₄" x 74 ⁷/₁₆" (each system).

inori freestanding

design Setsu & Shinobu Ito



Il sistema Inori Freestanding si sviluppa in situazioni autoportanti: nelle versioni in vetro e nella misura larga 240 cm, da altezza minima 135 cm sino all'altezza massima 180 cm, il sistema prevede delle barre di irrigidimento in alluminio anodizzato nero.

The system Inori offers free-standing solutions: in glass versions and in width 240 cm, from a height of minimum 135 cm up to the maximum height of 180 cm, the system is complete with black anodised aluminium reinforcement bars.

Le système Inori se présente dans des solutions autoportées: dans les versions en verre et dans la largeur de 240 cm, d'une hauteur minimale de 135 cm jusqu'à une hauteur maximale de 180 cm, le système est doté de barres d'armature en aluminium anodisé noir.

Das System Inori entwickelt sich als freistehender Raumteiler: in Glasausführung Breite 240 cm, Höhe mindestens 135 cm, maximal 180 cm, mit Verstärkungen aus Schwarz eloxiertem Aluminium.

Base in vetro fumè retroverniciato nero, ripiani in vetro fumè, montanti in vetro trasparente H 32 e 42 cm.

Black back-painted smoked glass bases, Smoked glass shelves, Transparent glass uprights, H 32 and 42 cm.

240 x 36,5 x 180 cm (con accessorio dedicato).
94 1/2" x 14 3/8" x 70 7/8" (with reinforcement bars).

Schede tecniche

Technical data

SPECCHI MIRRORS	phantom	80
TAVOLI TABLES	crystaline	82
	agos	84
	luxor	86
	corner	88
TAVOLI BASSI COFFEE TABLES	rialto	90
CONSOLLE CONSOLES	elementare	92
	charlotte	93
VETRINE SHOWCASES	palladio	94
SISTEMI SYSTEMS	inori	96

Schede tecniche

Technical data

phantom

design Helidon Xhixha
& Dante O. Benini - Luca Gonzo



Cornice in vetro fuso _ Fused glass frame



Trasparente
retroargentato
Back-silvered
glass

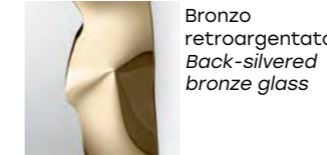

Bronzo
retroargentato
Back-silvered
bronze glass



Fumè
retroargentato
Back-silvered
smoked glass

Mod. A
190 x 15 x 90 cm
76 3/4" x 5 7/8" x 35 7/16"
Mod. B
198 x 18 x 98 cm
78" x 7" x 38 9/16"

Specchio da terra o da parete
in vetro fuso da 6 mm retro argentato,
specchio piano da 5 mm. Telaio
posteriore in metallo verniciato.
Possibilità di appendimento
verticale od orizzontale.

Free-standing or hanging
mirror in 6 mm high temperature
melted glass, back-silvered.
5 mm flat mirror. Rear frame
in painted metal. It can be hung
horizontally or vertically.

Miroir appuyant au mur
et accrochable en verre en fusion
de 6 mm argenté, miroir plat
de 5 mm. Cadre arrière en métal
verni. Possibilité d'accrochage
en horizontal ou en vertical.

Stand- bzw. Wandspiegel aus
geschmolzenem Glas versilbert.
Flacher Spiegel 5 mm stark.
Hinterer Rahmen aus lackiertem
Metall. Kann vertikal und horizontal
aufgehängt werden.

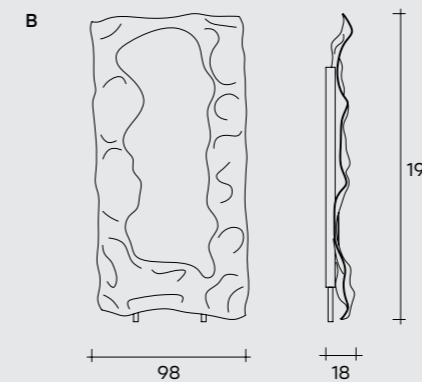
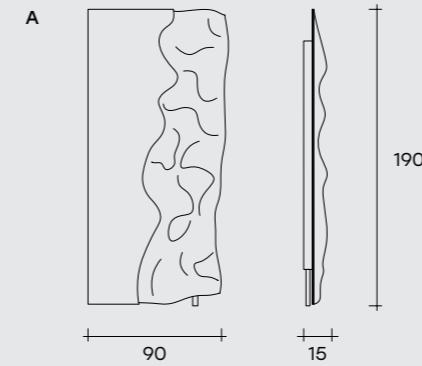

POSSIBILI POSIZIONI / POSSIBLE POSITIONS

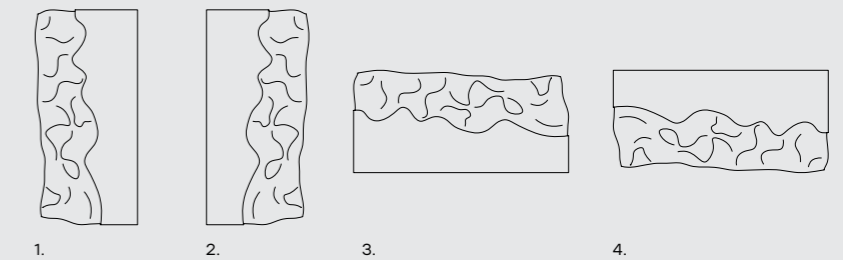

POSSIBILI POSIZIONI / POSSIBLE POSITIONS

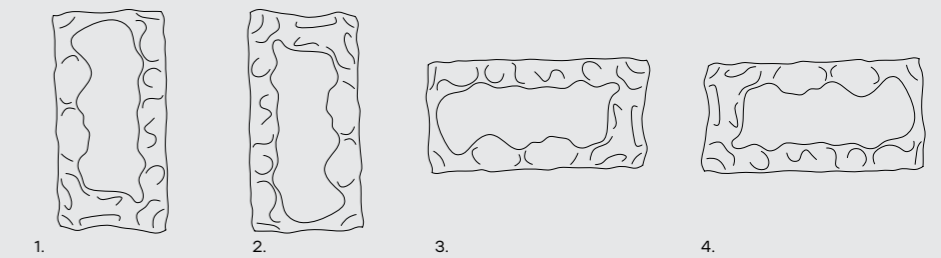

crystaline

design Marcel Wanders studio



Piano in vetro liscio _ Flat glass top



Vetro extralight
Extralight glass



Vetro fumé
Smoked glass



Vetro bronzo
Bronze glass

Piano in vetro fuso _ Fused glass top



Vetro extralight
Extralight glass



Vetro extralight
retroverniciato
Nero Brillante
Back-painted
extralight glass,
Brilliant Black finish



Vetro extralight
retroverniciato
Marrone Brillante
Back-painted
extralight glass,
Brilliant Brown finish

Base in metallo _ Metal base

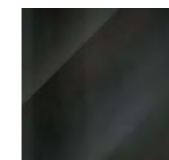

Nichel Nero Lucido
Black Glossy Nickel



Titanio Opaco
Opaque Titanium

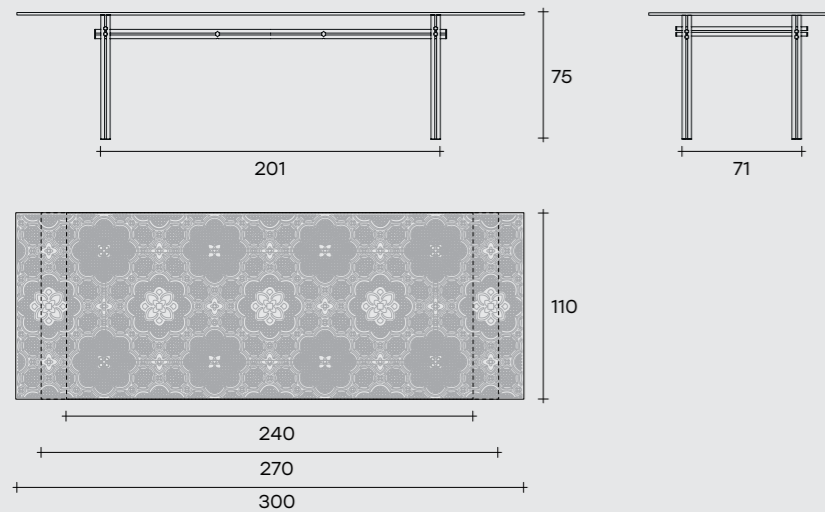

PARTICOLARE BISELLATURA BEVEL DETAIL

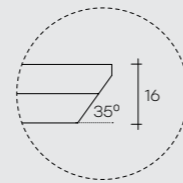

Tavolo con piano in vetro extralight da 15 mm fuso a gran fuoco e temperato, disponibile trasparente o retroverniciato con tinte metallizzate. Base in metallo finitura Titanio opaco oppure Nichel Nero lucido. Il piano è disponibile anche in vetro extralight da 15 mm temperato, oppure in vetro bronzo o fumé da 16 mm stratificato e bisellato.

Table with top in 15 mm fused and tempered extralight glass, available transparent or back-lacquered with metallic paints. Metal base available in opaque Titanium or in Black Glossy Nickel finishes. The top is available also in 15 mm tempered extralight glass, or in 16 mm bronze or smoked glass, layered and bevelled.

Table avec plateau en verre extra light de 15 mm en fusion et trempé, disponible transparent ou vernie dessous avec des teintes métallisées. Base en métal, finition Titane opaque ou Nickel noir brillant. Le plateau est disponible aussi en verre extra light de 15 mm trempé ou en verre feuilleté et biseauté.

Tisch mit platte aus 15 mm geschmolzenem und gehärtetem extralight Glas, transparent oder unterlackiert mit metallischen Farben erhältlich. Untergestell aus Metall in den folgenden Farbvarianten: Matt Titan oder Glanz Schwarz Nickel. Die Platte ist in den folgenden Varianten erhältlich: - 15 mm extralight gehärtetes Glas oder 16 mm geschichtete Bronze- bzw Rauchglas.

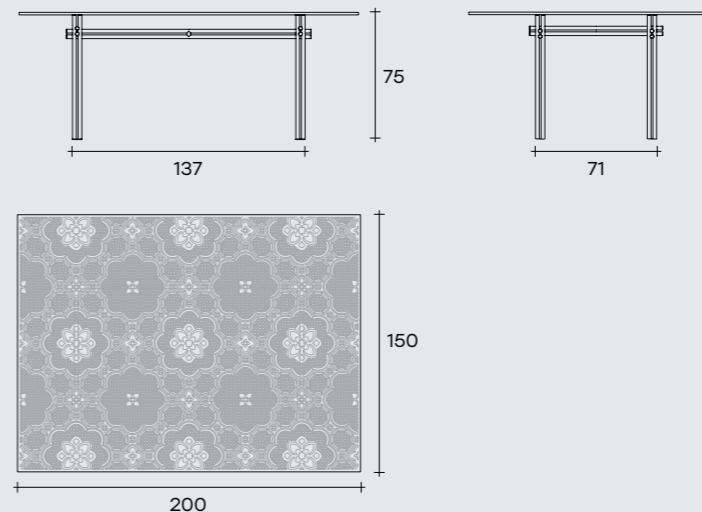

PARTICOLARE BISELLATURA BEVEL DETAIL

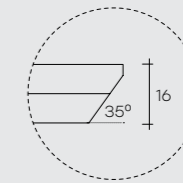

rettangolare / rectangular

240 x 110 x 75 cm
94 1/2" x 43 5/16" x 29 1/2"
270 x 110 x 75 cm
106 5/16" x 43 5/16" x 29 1/2"
300 x 110 x 75 cm
118 1/8" x 43 5/16" x 29 1/2"

falso quadrato / false square

200 x 150 x 75 cm
78 3/4" x 59" x 29 1/2"

agos

design Ludovica + Roberto Palomba



Piano in vetro liscio _ Flat glass top



vetro extralight
extralight glass



vetro fumé
smoked glass



vetro bronzo
bronze glass

Piano in vetro fuso _ Fused glass top



vetro extralight
extralight glass

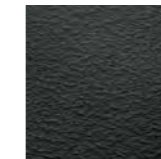

vetro extralight
retroverniciato
Nero Brillante
back-painted
extralight glass,
Brilliant Black finish



vetro extralight
retroverniciato
Marrone Brillante
back-painted
extralight glass,
Brilliant Brown finish

Base in metallo _ Metal base



Grigio Lava
Lava Grey

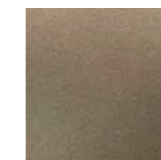

Greige Metallizzato
Metallic Greige

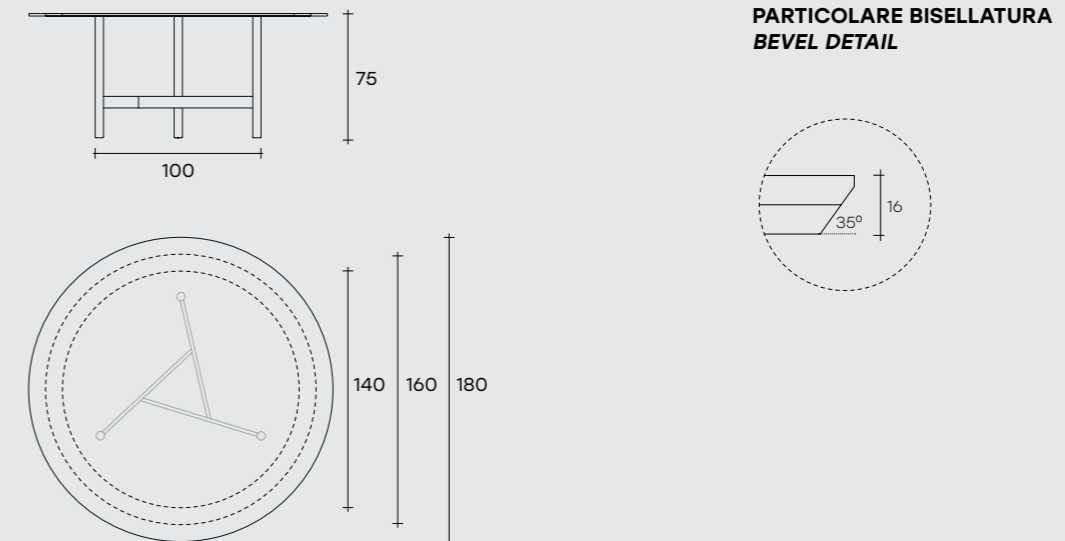
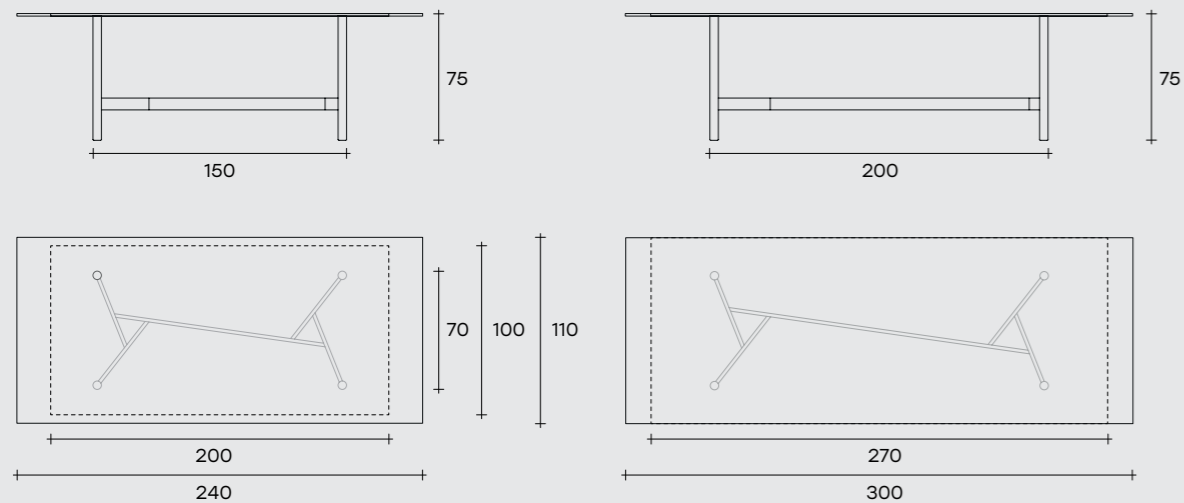

Tavolo con base in metallo verniciato, finitura Grigio Lava o Greige Metallizzato. Piano in vetro extralight da 15 mm fuso a gran fuoco e temperato, disponibile trasparente o retroverniciato con tinte metallizzate. Il piano è disponibile anche in vetro extralight da 15 mm temperato, oppure in vetro bronzo o fumé da 16 mm stratificato e bisellato.

Table with painted metal base, in Lava Grey or Metallic Greige finish. Top made of 15 mm extralight, fused and tempered glass, available transparent or back-painted with metallic colours. The top is available also in 15 mm tempered extralight glass, or in 16 mm bronze or smoked glass, layered and bevelled.

Table avec piètement en métal verni, finition Gris Lave ou Greige métallisé. Plateau en verre en fusion et trempé finition extra light de 15 mm, disponible transparent ou verni dessous avec des teintes métallisées. Le plateau est disponible aussi en verre extra light de 15 mm trempé ou en verre bronze ou fumé de 16 mm feuilleté et biseauté.

Tisch mit Gestell aus lackiertem Metall in der Farbe Lava Grau oder Metallish Greige. Platte aus 15 mm extralight gehärtetes Glas in den folgenden Varianten erhältlich: - verschmolzen, transparent oder mit Metallfarben unterlackiert - extralight mit Facettenschliff oder mit 16 mm geschichtete Bronze- oder Rauchglasplatte.

rettangolare / rectangular

200 x 100 x 75 cm
78 3/4" x 39 3/8" x 29 1/2"
240 x 110 x 75 cm
94 1/2" x 43 5/16" x 29 1/2"
270 x 110 x 75 cm
106 5/16" x 43 5/16" x 29 1/2"
300 x 110 x 75 cm
118 1/8" x 43 5/16" x 29 1/2"

tondo / round

ø 140 x 75 cm
ø 55 1/8" x 29 1/2"
ø 160 x 75 cm
ø 63" x 29 1/2"
ø 180 x 75 cm
ø 70 7/8" x 29 1/2"

luxor

design Rodolfo Dordoni

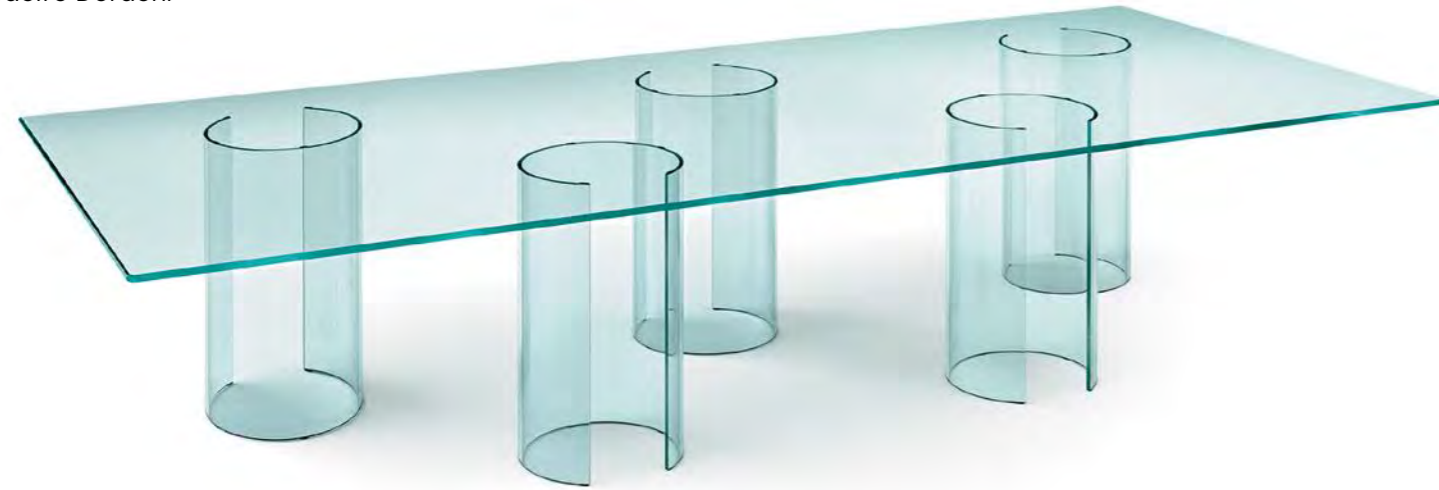

Base in vetro curvato _ Curved glass base

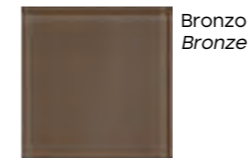

220 x 110 x 75 cm
86 5/8" x 43 5/16" x 29 1/2"

240 x 120 x 75 cm
94 1/2" x 47 1/4" x 29 1/2"

150 x 150 x 75 cm
59 1/16" x 59 1/16" x 29 1/2"

Tavolo con piano in vetro fumé o bronzo stratificato da 8+8 mm finitura filo lucido tondo, disponibile anche in vetro temperato trasparente o extralight. A seconda della misura e della configurazione desiderata base composta da 2, 3 o 4 cilindri (Ø 40 cm) in vetro da 10 mm, disponibile fumé, bronzo trasparente o extralight. Disponibile anche con piani a misura.

Dining table with layered glass top 8+8 mm-thick brilliant polished rim, in smoked or bronze glass also available in tempered glass, transparent or extralight. 10 mm-thick curved glass base, composed of 2, 3 or 4 cylinders (Ø 40 cm) depending upon the size and the shape requested. Bases are available in smoked glass, bronze glass, transparent glass or extralight glass. Custom size top available on request.

Table avec plateau en verre feuilleté de 8+8 mm fumé ou bronze finition chant poli arrondi, ou en verre trempé transparent ou extralight. Base en verre cintré de 10 mm se composant de 2, 3 ou 4 cylindres (Ø 40 cm) dépendant de la mesure ou de la configuration désirée. Disponible en verre fumé, en verre bronze, en verre transparent ou en verre extralight. La table Luxor est également disponible avec le plateau sur mesure.

Tisch mit 8+8 mm-starker Schichtglasplatte in Rauch- oder Bronze-Glas oder in transparentem bzw. extralight gehärtetem Glas. Untergestell bestehend aus 2, 3 bzw. 4 Zylindern (Durchmesser 40 cm) abhängig von den gewünschten Massen und Gestaltung, aus 10 mm-starkem gebogenem Glas, lieferbar in den Ausführungen Rauchglas, oder Bronzeglas, transparentes bzw. extralight Glas. Auch mit maßgefertigter Platte lieferbar.

PIANO RETTANGOLARE
RECTANGULAR TOP

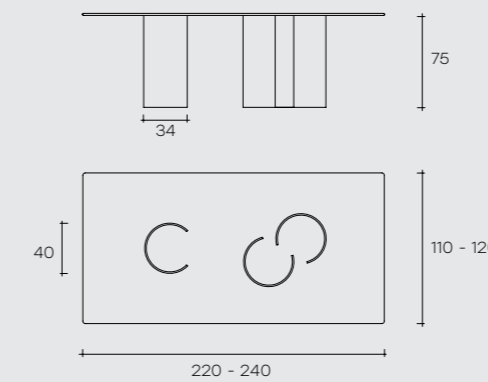

PIANO QUADRATO
SQUARE TOP

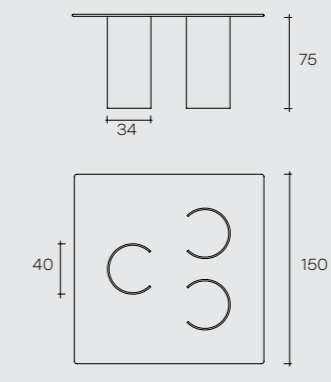

corner

design CRS Fiam

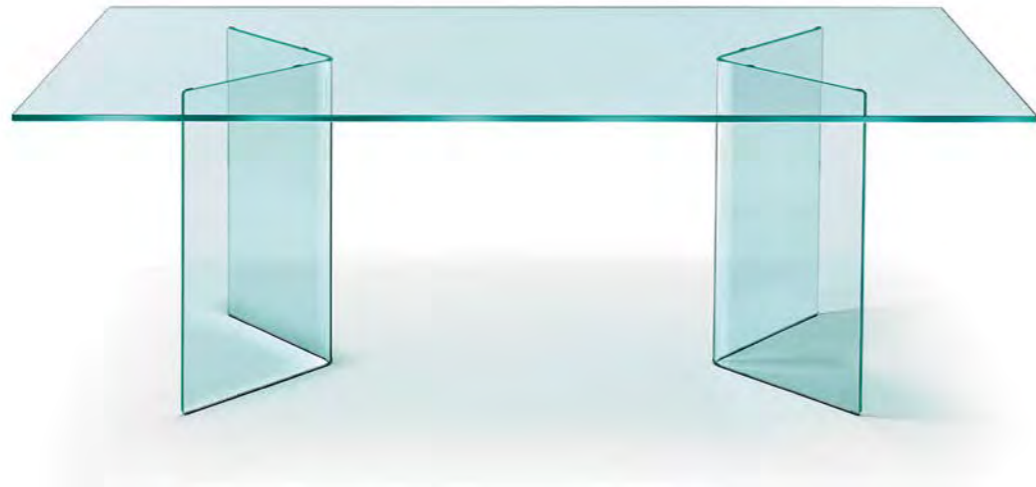

rettangolare / rectangular

170 x 80 x 75 cm
66 15/16" x 31 1/2" x 29 1/2"
180 x 90 x 75 cm
70 7/8" x 35 7/16" x 29 1/2"
220 x 110 x 75 cm
86 5/8" x 43 5/16" x 29 1/2"

quadrato / square

110 x 110 x 75 cm
43 5/16" x 43 5/16" x 29 1/2"
120 x 120 x 75 cm
47 1/4" x 47 1/4" x 29 1/2"
140 x 140 x 75 cm
55 1/8" x 55 1/8" x 29 1/2"

tondo / round

Ø 120 x 75 cm
47 1/4" x 29 1/2"
Ø 140 x 75 cm
55 1/8" x 29 1/2"

Tavolo composto da basi in vetro curvato da 12 mm con lati da 45 cm e piano in vetro da 15 mm temperato.

Table with 12 mm-thick curved glass base (sides 45 cm) and 15 mm-thick tempered glass top.

Table avec piètement en verre cintré de 12 mm, côtés de 45 cm. Plateau en verre trempé de 15 mm.

Tisch mit Untergestell aus 12 mm-starkem gebogenem Glas mit Winkeln von 45 cm. Gehärtete Glasplatte, Stärke 15 mm.

PIANO RETTANGOLARE RECTANGULAR TOP

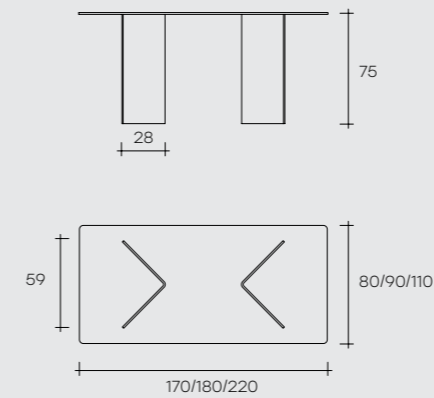

PIANO QUADRATO SQUARE TOP

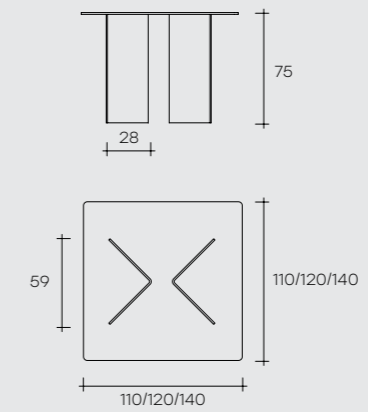

PIANO ROTONDO ROUND TOP

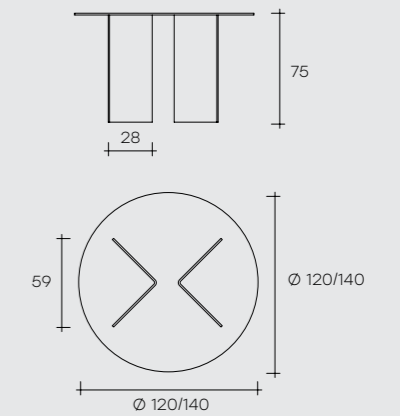

rialto

design CRS Fiam



Tavolo basso in vetro curvato.
Disponibile anche su misura.

Coffee table in curved glass.
Also available on customized size.

Table basse en verre cintré.
Egalement disponible sur mesure.

Couhtisch aus gebogenem Glas.
Auch als Maßanfertigung lieferbar.

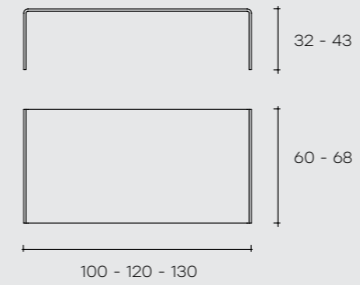

rettangolare / rectangular

100 x 60 x 32 cm
39 ³/₈" x 23 ⁵/₈" x 12 ⁵/₈"

120 x 60 x 32 cm
47 ¹/₄" x 23 ⁵/₈" x 12 ⁵/₈"

130 x 68 x 32 cm
51 ³/₁₆" x 26 ³/₄" x 12 ⁵/₈"

120 x 60 x 43 cm
47 ¹/₄" x 23 ⁵/₈" x 16 ¹⁵/₁₆"

130 x 68 x 43 cm
51 ³/₁₆" x 26 ³/₄" x 16 ¹⁵/₁₆"

elementare

design Enrico Tonucci

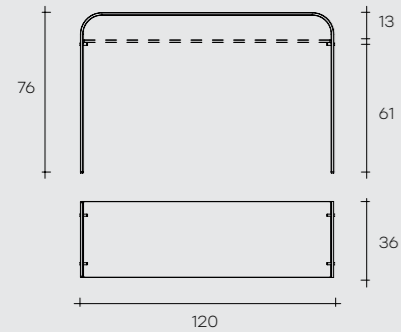

120 x 36 x 76 cm
47 1/4" x 14 3/16" x 29 5/16"

Consolle in vetro curvato da 12 mm.
Disponibile anche con ripiano in vetro
da 10 mm (L 117 cm, P 36 cm).

Console in 12 mm-thick curved glass.
Also available with 10 mm-thick glass
shelf (L 117 cm, W 36 cm).

Console en verre cintré de 12 mm.
Disponibile aussi avec étagère
en verre de 10 mm (L 117 cm, P 36 cm).

Konsole aus 12 mm-starkem
gebogenem Glas. Auch mit
Fachboden aus 10 mm-starkem
Glas (L 117 cm, B 36 cm) lieferbar.

charlotte

design Prospero Rasulo

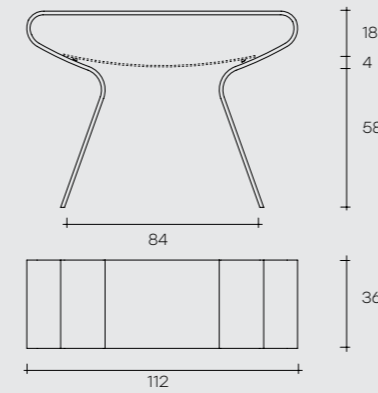

112 x 36 x 80 cm
44 1/8" x 14 3/16" x 31"

Consolle in vetro curvato da 15 mm.
Disponibile anche con ripiano
in vetro curvato acidato da 6 mm.

Console in 15 mm-thick curved glass.
Also available with 10 mm-thick
acid etched glass shelf.

Console en verre cintré de 15 mm.
Disponibile aussi avec étagère
en verre cintré dépoli de 6 mm.

Konsole aus 15 mm-starkem
gebogenem Glas. Auf Wunsch:
gebogener Fachboden aus
geätztem 6 mm-starkem Glas.

palladio

design Vittorio Livi



Vetrina elettrificata in vetro curvato da 6 mm con quattro ripiani fissi in vetro da 6 mm (L 58 cm, P 31 cm) e top in vetro da 12 mm. Profili in alluminio finitura brill spazzolato. Anta con serratura. Corpo illuminante (optional) posizionabile anche sotto il top.

Wired showcase in 6 mm-thick curved glass, with four 6 mm-thick glass shelves (L 58 cm, W 31 cm), 12 mm thick glass top, door with lock. Profiles in brushed aluminium glossy finish. The optional lights can also be placed under the top.

Vitrine électrifiée en verre cintré de 6 mm avec quatre étagères fixes en verre de 6 mm, top en verre de 12 mm, porte avec serrure. Profils en aluminium brossé finition brillante. Les projecteurs peuvent être positionnés aussi sous le plateau.

Vitrine aus 6 mm-starkem gebogenem Glas mit vier festen Fachböden aus 6 mm-starkem Glas. Ausgerüstet für eine Beleuchtung. Top aus 12 mm-starkem Glas. Profile aus gebürstetem glänzendem Aluminium Tür mit Schloss. Die Beleuchtung kann auch unter das Top angebracht werden.

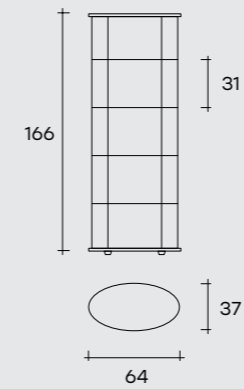

64 x 37 x 166 cm
25 3/16" x 14 9/16" x 65 3/8"

inori

design Setsu & Shinobu Ito



Basi / Bases

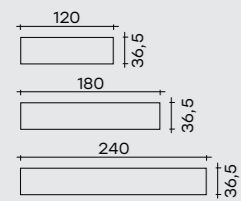

Montanti / Uprights

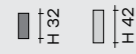

Ripiani / Shelves

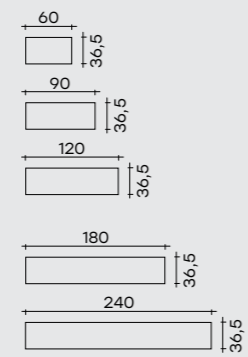

Disponibili solo nelle finiture vetro
In glass versions only
Pour les étagères en verre uniquement
Für die Glasfachböden nur

Disponibili in tutte le finiture
In all finishings
Pour toutes finitions
Für alle Finish

Sistema composto da elementi in vetro o legno modulari. La modularità e versatilità ne permette l'utilizzo come libreria, espositore, contenitore porta tv, sviluppabili sia in situazioni con fissaggio a muro che autoportanti. Tutti i montanti sono liberamente posizionabili tramite sistema di ancoraggio e scorrimento a binario applicato su ogni singolo ripiano. Binario in alluminio anodizzato nero.

Modular book shelves glass or wood system. The versatility and assembly possibilities allow the utilization as a show-case, display-case, TV-unit. Available the free-standing version and wall unit. The uprights are freely adjustable on each shelf through sliding rails and fixing device. Slides in anodized black aluminum.

Système composé d'éléments modulables en verre ou en bois. Sa modularité et sa versatilité permettent l'utilisation comme bibliothèque, présentoir, conteneur, portes-TV dans les versions soit appuyantes au sol soit accrochables au mur. Tous les montants sont positionnables avec un système de fixation et rail appliqué sur chaque étagère. Rail en aluminium anodisé noir.

System aus modularen Glas-oder Holz-Elementen. Vielseitig einsetzbar und beliebig kombinierbar, als Bücherregal, Ausstellungsregal, TV-Element usw. Verschiedene Kombinationen sind möglich, als freistehende Ausführung bzw. als Wandregal. Die Stützen sind frei verstellbar auf jedem Fachboden durch Führung und Befestigungsmodul. Laufschiene aus schwarzem eloxiertem Aluminium.

Base in legno _ Wood base

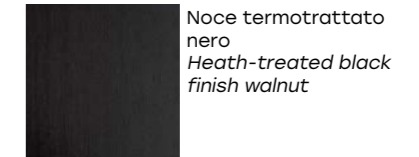
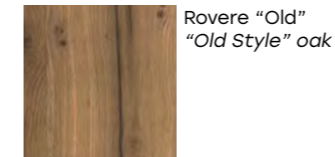

Base in vetro _ Glass base



Ripiano in legno _ Wood shelf

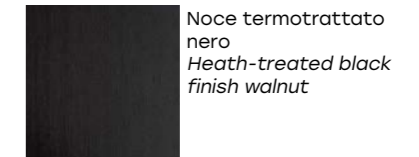

Ripiano in vetro _ Glass shelf

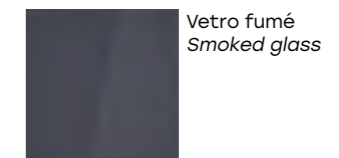

Montante in vetro curvato _ Curved glass upright

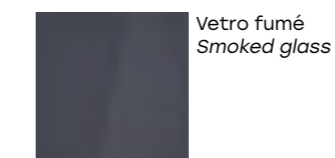
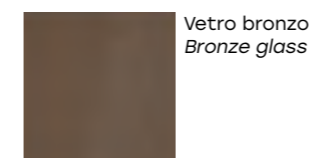
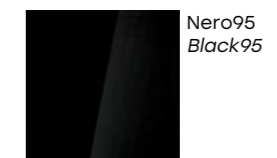

Tutti i montanti sono liberamente posizionabili tramite sistema di ancoraggio e scorrimento a binario applicato su ogni singolo ripiano. Binario in alluminio anodizzato nero.
 The uprights are freely adjustable on each shelf through sliding rails and fixing device. Slides in anodized black aluminum.
 Tous montants sont positionnables avec un système de fixation et rail appliqué sur chaque étagère. Rail en aluminium anodisé noir.
 Die Stützen sind frei verstellbar auf jedem Fachboden durch Führung und Befestigungsmodul. Laufschiene aus schwarzem eloxiertem Aluminium.



Alcuni suggerimenti tra le infinite soluzioni _ Just a few of the numerous solutions
 Quelques suggestions parmi de nombreuses possibilités _ Einige Vorschläge zu unzähligen Lösungen

Libreria _ Bookcase _ Bibliothèque _ Bücherregal

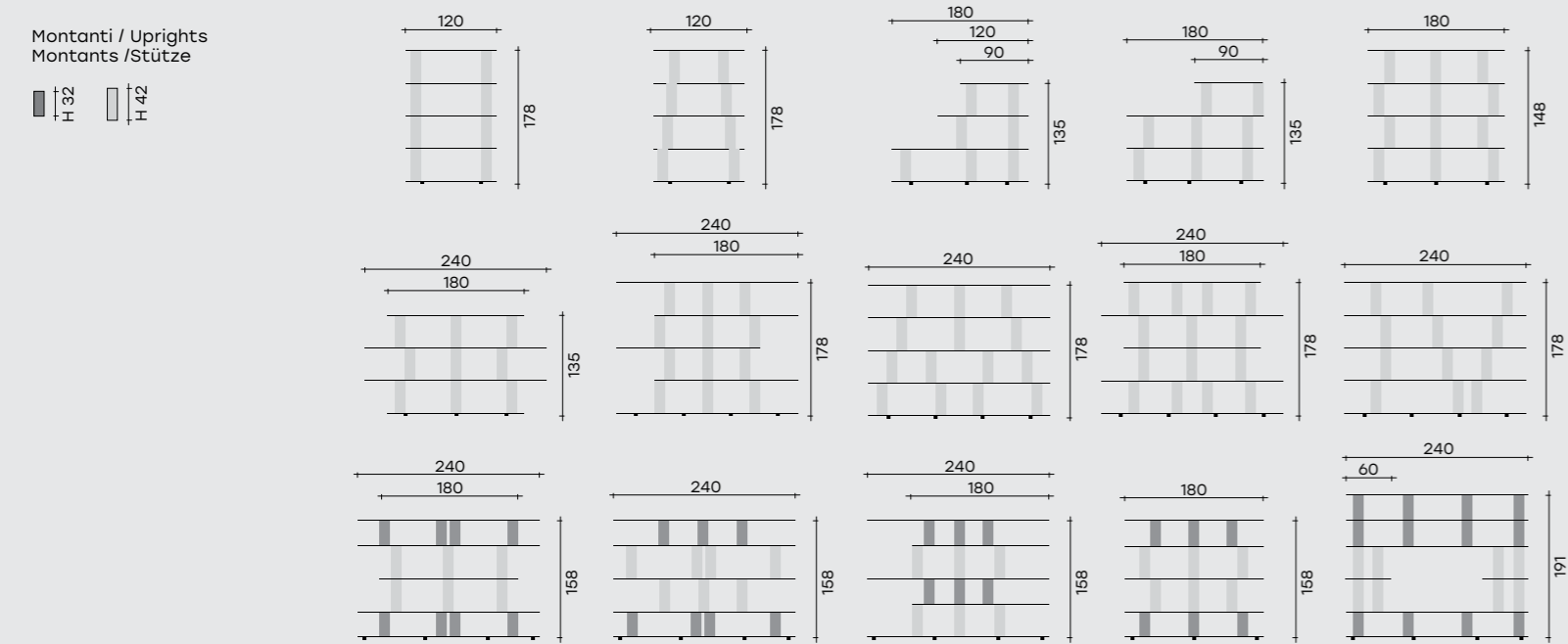

Porta TV _ Tv unit _ Porte-TV _ TV-Ständer

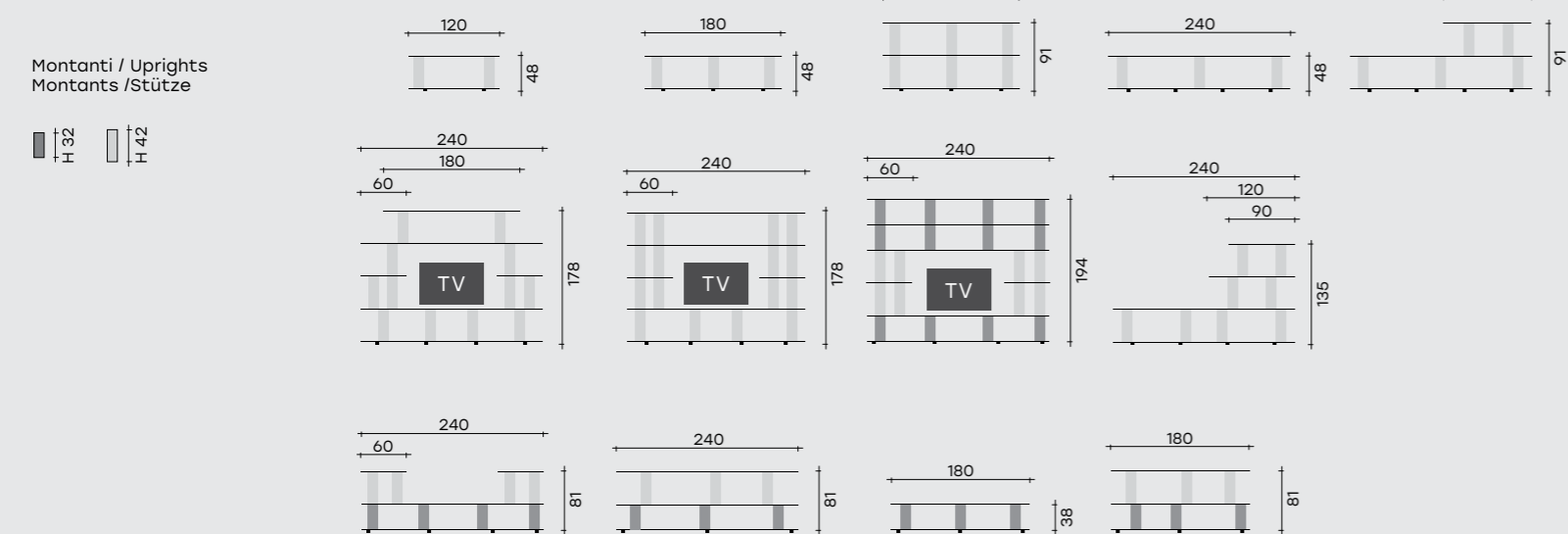

Consolle _ Console _ Console _ Konsole

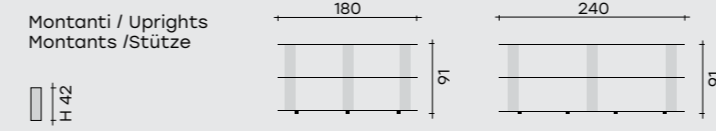

Retro divano _ Sofa back sideboard _ Bout de Canape _ Sofa Hinterelement

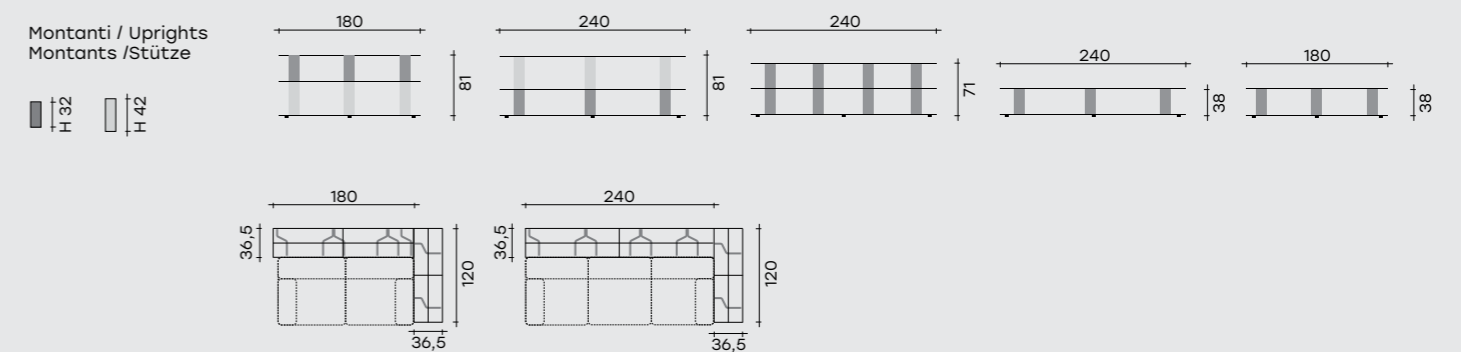

Mobile basso _ Low unit _ Meubles bas _ Kleinmöbel

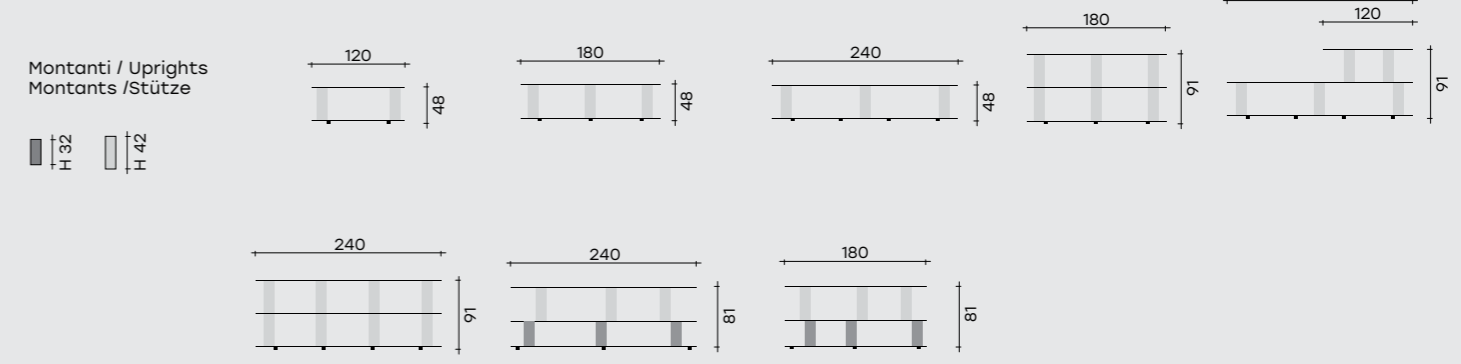

Soluzione centrostanza _ Room centrepiece solution _ Solution en séparation de pièces _ Zimmermitte-Lösung

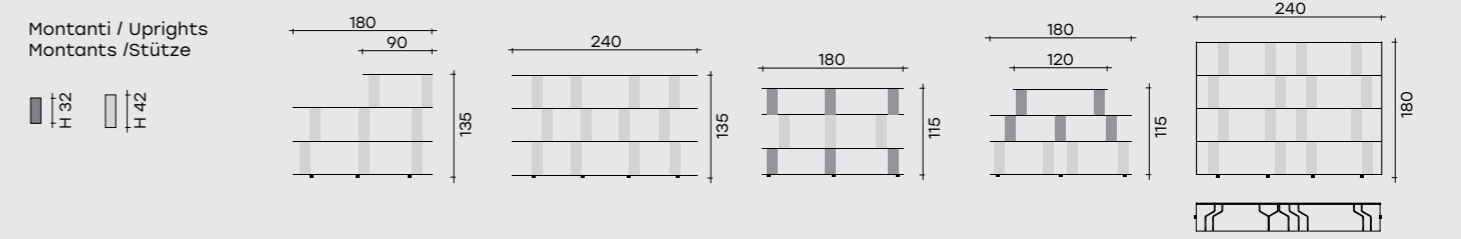

Altezza massima per le strutture autoportanti:
 - Su basi di lunghezza 120 cm: h max 48 cm (vetro) o 51 cm (legno).
 - Su basi di lunghezza 180 cm: h max 135 cm (vetro) o 143 cm (legno).
 - Su basi di lunghezza 240 cm: h max 178 cm (vetro) o 189 cm (legno) con accessorio dedicato.
Altezza massima per le strutture con ancoraggio a muro:
 - Massimo 5 ripiani in vetro, 6 ripiani in legno, base esclusa.
Distanza massima tra i montanti: 130 cm.

Max. height of the free-standing version:
 - With base length 120 cm: h max 48 cm (glass) or 51 cm (wood).
 - With base length 180 cm: h max 135 cm (glass) or 143 cm (wood).
 - With base length 240 cm: h max 178 (glass) or 189 cm (wood) with accessories.
Max. height of the wall version:
 - Max 5 glass shelves, max 6 wood shelves, base excluded.
Max. distance between the uprights: 130 cm.

Hauteur maxi. pour les structures posées au sol:
 - Avec base de longueur 120 cm: h max 48 cm (verre) ou 51 cm (bois).
 - Avec base de longueur 180 cm: h max 135 cm (verre) ou 143 cm (bois).
 - Avec base de longueur 240 cm: h max 178 cm (verre) ou 189 cm (bois) avec accessoires.
Hauteur maxi. pour les structures accrochables au mur:
 - Avec max 5 étagères en verre, max 6 étagères en bois, base excluse.
Distance maxi entre les montants: 130 cm.

Max. Höhe der Standausführung:
 - Mit Basislänge 120 cm: h max 48 cm (Glas) or 51 cm (Holz).
 - Mit Basislänge 180 cm: h max 135 cm (Glas) or 143 cm (Holz).
 - Mit Basislänge 240 cm: h max 178 cm (Glas) or 189 cm (Holz) mit Accessoires.
Max.Höhe der Wandausführung:
 - Mit max 5 Glasfachböden, max 6 Holzfachböden, ohne die Basis.
Max. Abstand zwischen den Stützen: 130 cm.

FIAM è certificata UNI EN ISO 9001; la conformità a questa norma di riferimento permette a FIAM di raggiungere altissimi standard qualitativi. Una delle testimonianze dirette è la rintracciabilità dei suoi manufatti: ogni prodotto FIAM reca una decalcomania indelebile, cotta ad altissima temperatura, nella quale viene riportato oltre al marchio aziendale, un codice che permette di ricostruire il suo intero ciclo produttivo.

FIAM est une entreprise certifiée UNI EN ISO 9001; la conformité à cette norme de référence permet à FIAM d'atteindre des niveaux de qualité très élevés. La traçabilité des produits en est une preuve: chaque produit FIAM porte une décalcomanie indélébile, cuite à très haute température, qui mentionne la marque de l'entreprise et un code permettant de reconstruire tout son cycle de production.

Fiam is certified UNI EN ISO 9001; the conformity to this reference norm allows Fiam to reach the highest quality standards. One of the direct evidences is the possibility to track of the products: a high temperature and therefore indelible decal is applied to every article, in addition to the company logo, this decal also bears a number of codes that allow the production cycle details of the article to be traced.

FIAM ist nach UNI EN ISO 9001 zertifiziert und garantiert damit für höchste Qualitätsstandards. Dazu gehört auch die Nachverfolgbarkeit des Entstehungsweges der Erzeugnisse: Jedes FIAM-Produkt wird mit einem bei hohen Temperaturen eingebrannten Abziehbild versehen, auf dem neben dem Markenzeichen des Herstellers eine Identifikationsnummer steht, anhand der sich der gesamte Produktionszyklus des Artikels nachverfolgen lässt.

AZIENDA CON SISTEMA DI GESTIONE
PER LA QUALITÀ CERTIFICATO DA ICILA
UNI EN ISO 9001

Fiam, garanzia di qualità

Fiam, guarantee of quality



art direction
adele martelli

photo art direction
adele martelli
acanto comunicazione
(carlo piazzesi)

rendering images
acanto comunicazione

photography and postproduction
studio amatibacciardi
studio leon

styling
monti studio
candida zanelli and serenella parri
conti | marchetti studio

marketing project
daniele livi

coordination and logistics
lorenzo marzoli

selections
olimpia visual plan

september 2023

Fiam Italia
Via Ancona 1/b
61010 Tavullia (PU)
Italy

T: +39 0721 20051
F: +39 0721 202432

fiamitalia.it
info@fiamitalia.it

#fiamitalia

follow us on



credits

ALESSI
ALFRED DRAGO RENS - GALLERIA L'AFFICHE
AMINI CARPET
ANTONINO SCIORTINO
APPLE
ARFLEX
ARTEK
ATELIER POLYHEDRE
AXIL
AYTM
BAXTER
BOFFI
BONACINA 1889
BPA INTERNATIONAL
BUSNELLI di Gruppo Industriale Busnelli
CAPPELLINI
CARPET EDITION
CECILIA MARINO
CERAMICHE ARTISTICHE BOTTEGA VIGNOLI
CINOVA di Gruppo Industriale Busnelli
COHEN SEDGH TAPPETI
COOEE DESIGN
CORAXART
D3CO
DAVIDE LOVATTI
DEDAR
DE PADOVA
DESALTO
EDD
EDIZIONIDESIGN
ENTRATA LIBERA
FELIS
FFERRONE DESIGN
FIAMMETTA MARMI
FIANDRE ARCHITECTURAL SURFACES / IRIS CERAMICA
FINN FORM PER ITTALA
FLOS
FLOU
FONTANAARTE
FOSCARINI
GALLERIA ARTRA MILANO
GOLRAN
HK LIVING
IL FANALE GROUP
IL LOFT
INCIPITLAB
JAB
KASTHALL
LES OTTOMANS
LISTONE GIORDANO
LIVING DIVANI
LUCEPLAN
MANI BY BRITTA HERRMANN
MARINO CRISTAL
MARTA FULVI
MARTINELLI LUCE
MATI
MATTIAZZI
MM LAMPADARI
MODO LUCE
MOROSO
MY HOME COLLECTION
NAHOOR
NANIMARQUINA
OLUCE
OPIFICIO SERICO FIORENTINO
ORIZZONTI
PANZERI ILLUMINAZIONE
PIANCA E OTTOEMEZZO
POLIFORM
RAW
RATTI BOUTIQUE
REZINA
RINA MENARDI
ROMAGNOLI ARREDAMENTI PESARO
ROSENTHAL
SALVIATI
SAMBONET
SANTA & COLE
SCANDOLA MARMI
SERVOMUTO
SFORZIN ILLUMINAZIONE
SILVA TESSUTI
TATO ITALIA
TOOY
VIBIEFFE 85
VERY WOOD
VITRA
ZAFFERANO
ZENO FINOTTI SCULTURE