



□FIAM

Collection  
2026

**Prodotti** \_\_\_\_\_ 04  
Products

**ogiva** \_\_\_\_\_ 04  
tavolo, table

**trivium** \_\_\_\_\_ 14  
tavolo, table

**brenta** \_\_\_\_\_ 22  
sedia, chair

**still** \_\_\_\_\_ 28  
specchio, mirror

**istante** \_\_\_\_\_ 36  
specchio, mirror

**asteroids** \_\_\_\_\_ 44  
tavolino, coffee table

**segesta bar** \_\_\_\_\_ 52  
madia, cupboard

**onair** \_\_\_\_\_ 58  
poltrona, armchair

**Schede tecniche** \_\_\_\_\_ 62  
Technical data

Vetro. Materia unica, plasmabile e dalle mille possibilità interpretative. Non più solo etereo, è ora protagonista di una nuova dimensione, tridimensionale, materico ma sempre raffinato ed attuale, originale ed inaspettato, che oggi declinato nelle varie collezioni di prodotti all'interno dei MOOD FIAM riesce ad accogliere a tutto tondo chi li vive, regalando sensazioni di piacevolezza, comfort, naturalezza.

Con le nuove collezioni 2026 continuiamo a perseguire con maestria la nostra mission: elevare il materiale vetro a materia viva, calda e distintiva in dialogo con materiali raffinati in un equilibrio sofisticato di forme e colori. Superfici morbide e sinuose si legano al legno massello ed a metalli preziosi, al marmo così come ad imbottiti sorprendenti, dando vita ad un unicum sobrio e coerente di complementi del desiderio per la dimora contemporanea.

Il risultato è uno spazio caldo e raffinato, sofisticato ma equilibrato ed accogliente, in cui immergersi e lasciarsi avvolgere.

### FIAM Italia Collezioni 2026

Glass. A singular material, malleable, open to countless interpretations. No longer merely ethereal, it becomes the protagonist of a new dimension: three-dimensional, tactile, yet always refined and contemporary, original and unexpected. Today, expressed through the diverse product collections within the FIAM MOODS, it fully embraces those who inhabit them, offering sensations of pleasure, comfort, and natural ease.

With the new 2026 collections, we continue to pursue our mission with mastery: to elevate glass into a living material, warm and distinctive, engaged in dialogue with refined elements, in a sophisticated balance of forms and colours. Soft, sinuous surfaces intertwine with solid wood and precious metals, with marble as well as surprising upholstered pieces, giving rise to a sober and coherent unicum of desirable furnishings for the contemporary home.

The result is a space that is warm and refined, sophisticated, yet balanced and welcoming, an environment to immerse oneself in and be gently enveloped by.

**FIAM Italia Collections 2026**

Verre. Matière unique, malléable, aux mille possibilités d'interprétation. Plus seulement éthéré, il devient aujourd'hui le protagoniste d'une nouvelle dimension: tridimensionnelle, matérielle, mais toujours raffinée et contemporaine, originale et inattendue. Décliné à travers les différentes collections de produits au sein des MOOD FIAM, il accueille pleinement ceux qui les vivent, offrant des sensations de plaisir, de confort et de naturalité.

Avec les nouvelles collections 2026, nous poursuivons avec maîtrise notre mission: élever le verre au rang de matière vivante, chaleureuse et distinctive, en dialogue avec des matériaux raffinés, dans un équilibre sophistiqué de formes et de couleurs. Des surfaces douces et sinueuses s'unissent au bois massif et aux métaux précieux, au marbre ainsi qu'à des pièces rembourrées surprenantes, donnant naissance à un ensemble sobre et cohérent de pièces désirables pour l'habitat contemporain.

Le résultat est un espace chaleureux et raffiné, sophistiqué mais équilibré et accueillant, dans lequel s'immerger et se laisser envelopper.

**FIAM Italia Collections 2026**

Glas. Ein einzigartiges Material, formbar und reich an unzähligen Interpretationsmöglichkeiten. Nicht länger nur ätherisch, wird es heute zum Protagonisten einer neuen Dimension: dreidimensional, materiell und zugleich stets raffiniert und zeitgemäß, originell und überraschend. In den verschiedenen Produktkollektionen innerhalb der FIAM MOODS entfaltet es sich in seiner ganzen Ausdruckskraft und heißt jene willkommen, die sie erleben, indem es Empfindungen von Wohlbefinden, Komfort und Natürlichkeit vermittelt.

Mit den neuen Kollektionen 2026 verfolgen wir unsere Mission weiterhin mit meisterlicher Präzision: Glas zu einer lebendigen, warmen und unverwechselbaren Materie zu erheben, im Dialog mit edlen Materialien, in einem anspruchsvollen Gleichgewicht von Formen und Farben. Weiche, geschwungene Oberflächen verbinden sich mit Massivholz und edlen Metallen, mit Marmor ebenso wie mit überraschenden Polsterelementen und schaffen so ein stimmiges, zurückhaltendes Gesamtbild begehrter Einrichtungselemente für das zeitgenössische Wohnen.

Das Ergebnis ist ein Raum, der warm und edel, anspruchsvoll und dennoch harmonisch und einladend wirkt. Ein Ort zum Eintauchen und umhüllen.

**FIAM Italia Kollektionen 2026**



Ogiva nasce da una riflessione sul dialogo tra materia e tensione, tra trasparenza e massa. Nel suo nome vive un archetipo architettonico antico, l'arco ogivale: una forma capace di trasformare la gravità in slancio. Ho voluto evocare la stessa energia in un sistema di tavoli che fosse insieme struttura e attraversamento, presenza e luce. Il piano in vetro, cifra identitaria di FIAM, è realizzato in vetrofusione e si offre come una superficie attraversata dalla luce. Non è una trasparenza assoluta, ma una materia vibrante, capace di filtrare e diffondere la luminosità con profondità. La vetrofusione trattiene la luce e la restituisce con morbidezza, lasciando intravedere la struttura metallica sottostante, che affiora e si ritrae a seconda dell'incidenza luminosa e del punto di vista.

È nell'inclinazione e nell'innesto sotto il piano che si costruisce la tensione del progetto. Le gambe, volutamente volumetriche e scolpite, sono presenze plastiche compatte che introducono un contrappunto deciso rispetto alla leggerezza del vetro. Il contrasto tra l'opacità del metallo e la luminosità stratificata del piano non è opposizione, ma dialogo. Ogni gamba muta a seconda del lato da cui la si osserva, restituendo profili differenti e nuovi rapporti tra pieni e vuoti. Camminando intorno al tavolo, l'immagine non è mai statica, ma in continua trasformazione.

Ogiva began as a reflection on tension. Between matter and lightness. Between weight and lift. Its name refers to the pointed arch, an ancient architectural form capable of transforming gravity into upward thrust. I wanted to translate that structural principle into a domestic scale, creating a family of tables that operate simultaneously as structure and passage, presence and light. The glass top, central to FIAM's material language, is created through glass fusion. It is not neutral transparency, but a crafted surface that filters and modulates light with depth. The fused glass holds luminosity within its body, allowing the metal structure beneath to emerge and recede according to viewpoint and changing light conditions. The perception shifts as one moves around it. It is in the inclination and in the way the elements meet beneath the top that the project's internal tension takes shape. The legs are volumetric, almost sculptural presences. Their opacity intensifies the luminosity of the glass rather than opposing it. Each angle reveals a different profile, subtly recalibrating balance and weight.

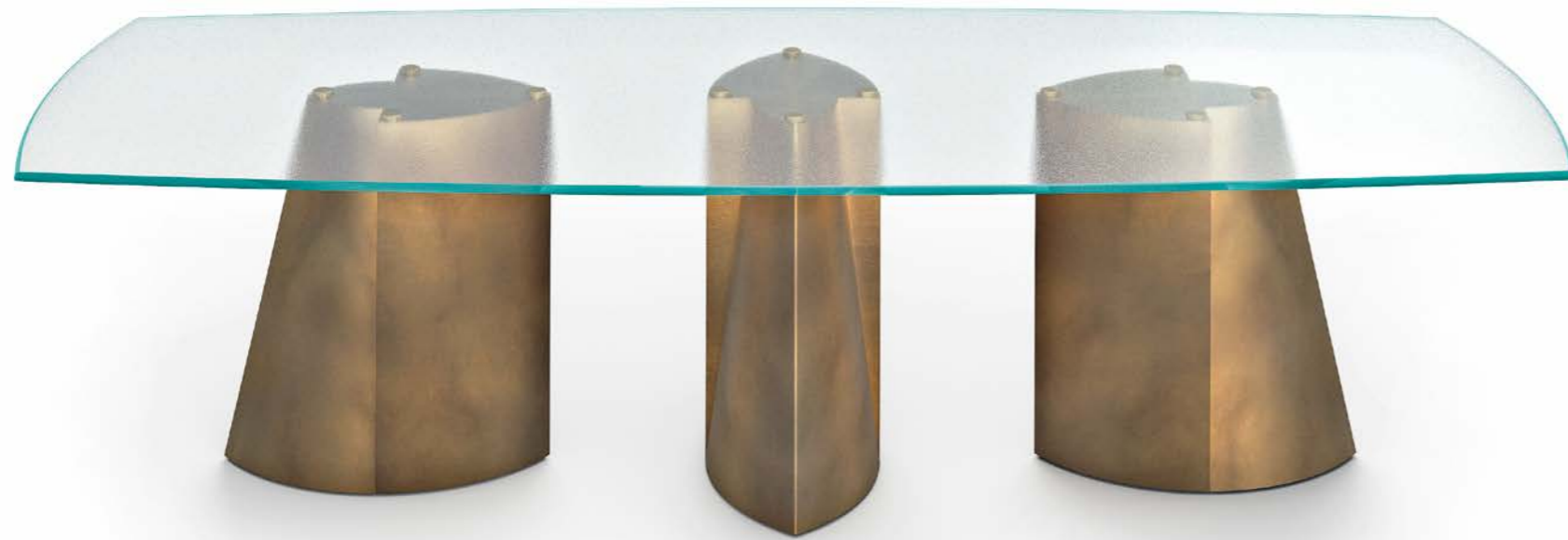

Burnished Brass bases;  
Fused glass top.  
300 x 118 x H75 cm

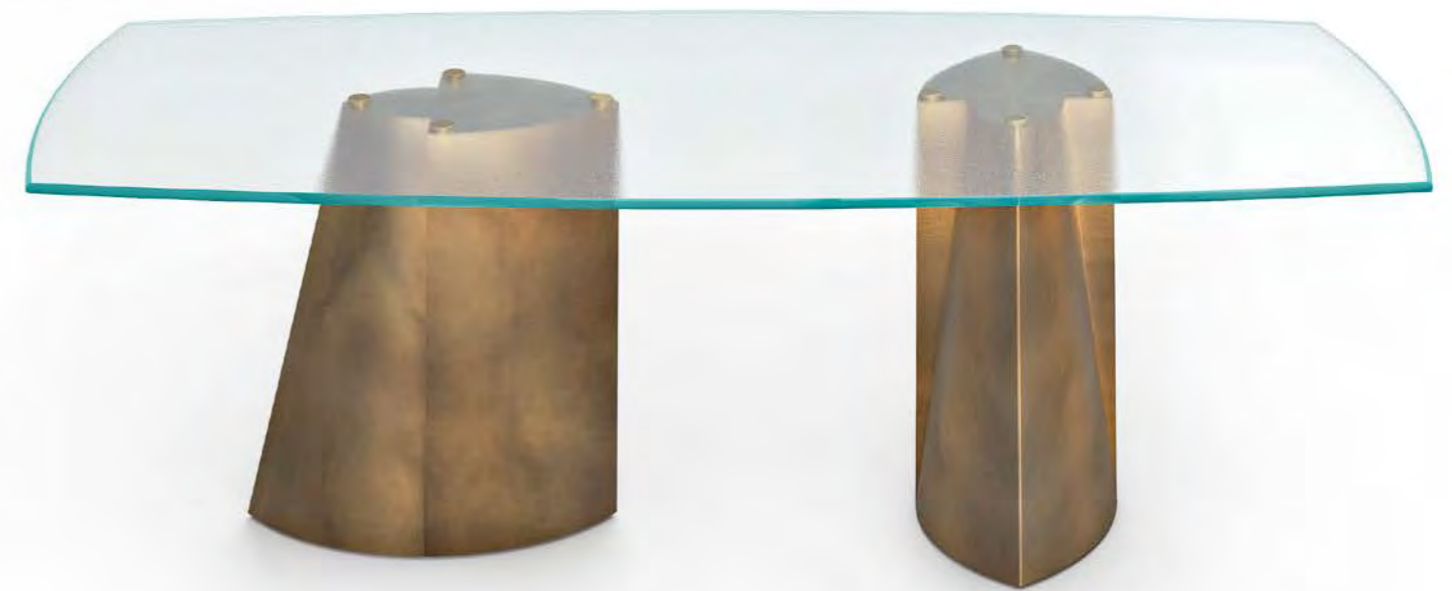

Burnished Brass bases;  
Fused glass top.  
240 x 110 x H75 cm

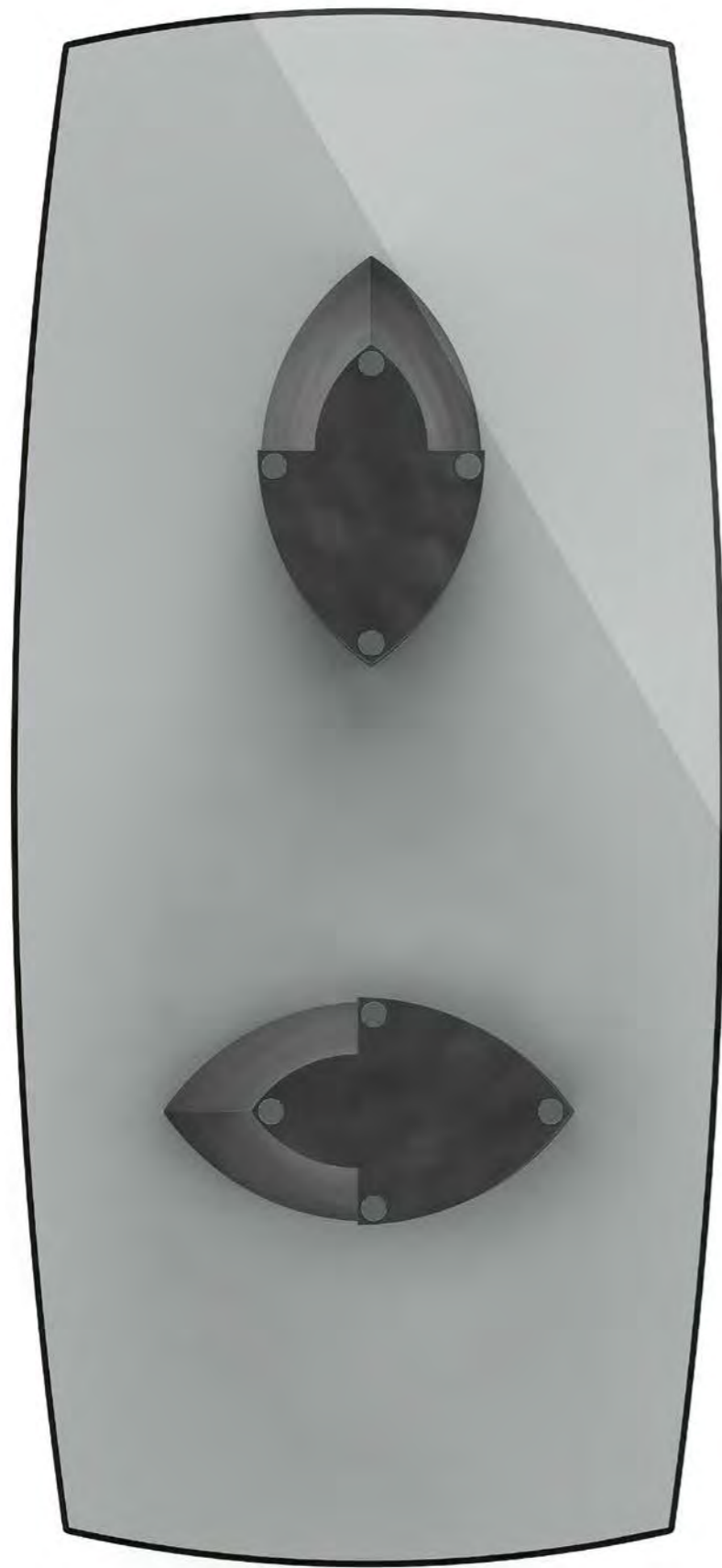

Peltro finish bases;  
Layered smoked glass top.  
240 x 110 x H75 cm



Metallic Greige lacquered base;  
Mystic Brown marble top.  
ø180 x H77 cm



Metallic Greige lacquered base;  
Layered bronze glass top.  
ø180 x H75 cm



Burnished Brass bases;  
Calacatta Royal marble top.  
300 x 118 x H77 cm

Trivium nasce dall'incontro di due anime: il vetro, cuore pulsante dell'azienda, sofisticato e luminoso, e il legno, materia viva che dona solidità e carattere.

Nei cavalletti triangolari, costruiti come piccole architetture domestiche, i materiali non si sovrappongono ma si cercano, in equilibrio dinamico.

È un progetto che racconta un abbraccio: tra trasparenza e materia, tra visione e radicamento.

Trivium emerges from the meeting of two distinct souls: glass, the company's beating heart—refined and luminous—and wood, a living material that lends solidity and character.

In the triangular trestles, shaped as small domestic architectures, the materials do not overlap but seek one another, held in dynamic balance.

It is a project that speaks of an embrace: between transparency and substance, between vision and grounding.

**trivium**  
Meneghello Paolelli

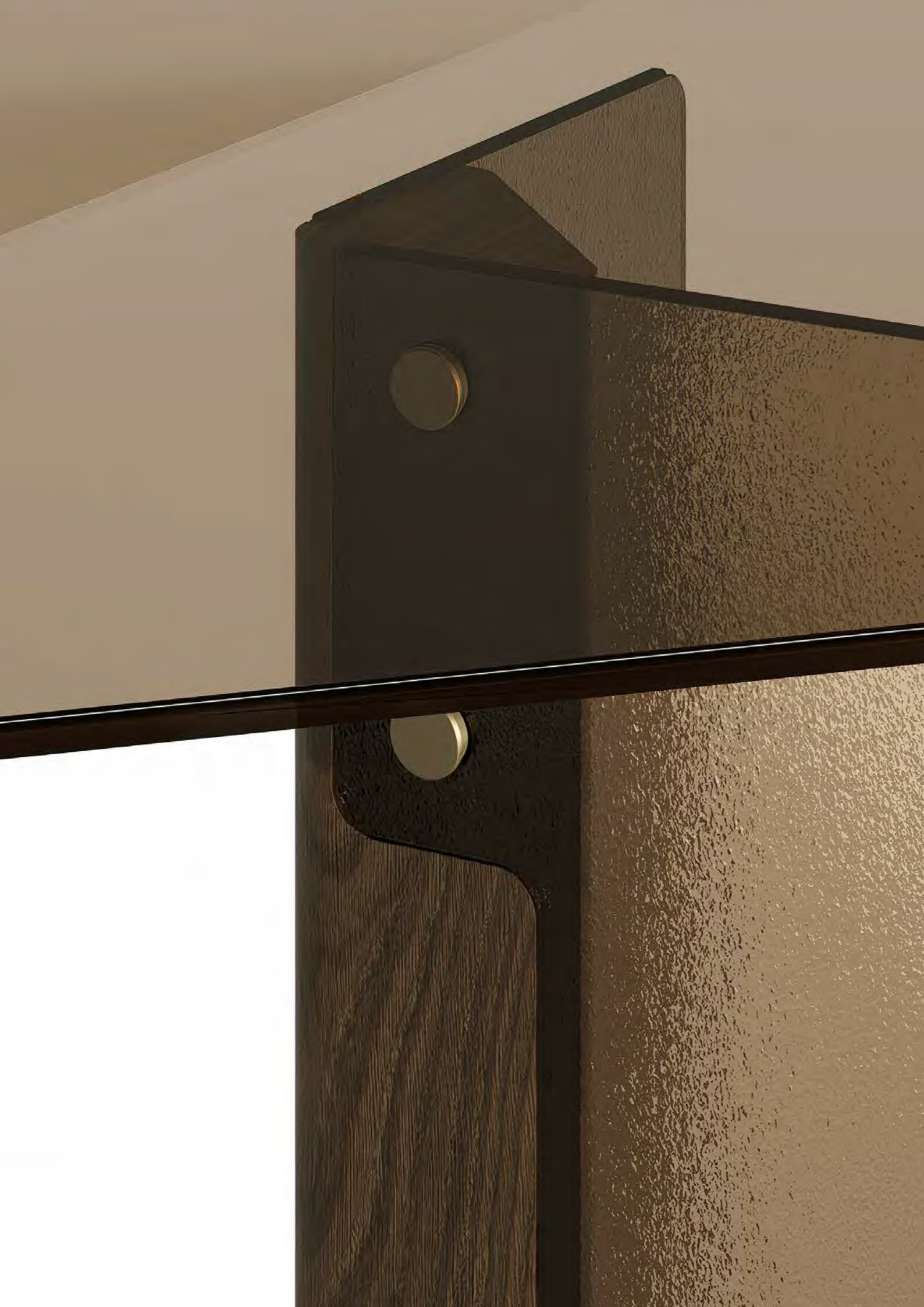



Fused bronze glass and Tobacco finish solid wood bases;  
Layered bronze glass top.  
260 x 110 x H75 cm



Fused smoked glass and Black finish solid wood bases;  
Layered smoked glass top.  
260 x 110 x H75 cm



Fused smoked glass and Black finish solid wood bases;  
Canaletto walnut, Black finish top.  
260 x 110 x H77 cm



Fused bronze glass and Tobacco finish solid wood bases;  
Canaletto walnut, Tobacco finish top.  
260 x 110 x H77 cm

L'obiettivo è stato quello di disegnare una sedia imbottita capace di inserirsi con naturalezza nella varietà degli ambienti Fiam, mantenendo al tempo stesso una connotazione estetica precisa e riconoscibile. In pieno spirito Fiam, dove ogni pezzo nasce da un ragionamento progettuale autonomo e dialoga con lo spazio per contrappunto e non per assonanza, la sedia Brenta si fonda su un segno grafico chiaro: un fianco sagomato in legno massello che unisce seduta e schienale in pelle o in tessuto, diventando struttura portante. Un gesto progettuale netto ed essenziale che definisce una seduta capace di farsi riconoscere rimanendo discreta, in un perfetto equilibrio tra rigore e identità.

The goal was to design an upholstered chair capable of naturally fitting into the variety of Fiam environments, while maintaining a precise and recognizable aesthetic identity.

In true Fiam spirit, where each piece stems from an autonomous design reasoning and engages with the space through counterpoint rather than formal resemblance, the Brenta chair is built around a clear graphic gesture: a shaped solid wood side element that connects the seat and backrest in leather or fabric, becoming the structural core. A sharp and essential design move that defines a chair able to stand out while remaining discreet, achieving a perfect balance between rigor and identity.



Black finish solid wood structure;  
Black One leather upholstery.

**brenta**  
Simone Bonanni



Tobacco finish solid wood structure;  
Dark Brown Nubuck upholstery.



Tobacco finish solid wood structure;  
Dark Brown One leather upholstery.





Black finish solid wood structure;  
Chestnut Brown Nubuck upholstery.



Still è uno specchio che indaga il riflesso come forma, materia ed esperienza. Ispirato alla superficie silenziosa dei laghi alpini ed al paesaggio circostante, il progetto traduce la presenza calma dell'acqua in un gesto scultoreo preciso, in cui l'immobilità diventa una condizione attiva, non uno stato passivo.

Al centro del progetto c'è il vetro, materia per sua natura legata alla trasformazione. Portato a uno stato morbido e modellato attraverso processi controllati, ritorna alla solidità conservando la memoria del movimento. Questa dualità ne influenza il design: una superficie che appare stabile ma suggerisce il fluire, catturando l'istante in cui il liquido diventa forma.

Lo specchio si pone come interfaccia tra oggetto e ambiente. Più che riflettere, riformula lo spazio, frammentando e ricomponendo il paesaggio circostante attraverso lievi distorsioni e slittamenti percettivi. Luce, contesto e posizione dell'osservatore ridefiniscono continuamente l'oggetto, trasformando il riflesso in un evento in costante evoluzione.

Still is a mirror that investigates reflection as form, material, and experience. Inspired by the silent surface of alpine lakes and the surrounding landscape, the project translates the calm presence of water into a precise, sculptural gesture, where stillness becomes an active condition rather than a passive state.

At the center of the project is glass, a material defined by transformation. Heated to a soft state and shaped through controlled processes, it returns to solidity while retaining the memory of movement. This duality informs the design language: a surface that appears stable yet suggests flow, capturing the moment where liquid becomes form.

The mirror operates as an interface between object and environment. Rather than simply reflecting, it reframes space, fragmenting and recomposing the surrounding landscape through subtle distortions and shifts in perception. Light, context, and the viewer's position continuously redefine the object, making reflection an evolving event.



Rectangular mirror,  
standard finish.  
130 x 10 x 200 cm



Rectangular mirror,  
smoked finish frame.  
130 x 10 x 200 cm





Rectangular mirror,  
bronze finish frame.  
130 x 10 x 200 cm



Round mirror,  
standard finish.  
ø130 x 10 cm



Istante trasforma l'idea dell'attimo catturato in un'oggetto di vetro, dove chi si specchia diventa protagonista della propria quotidianità. Un rettangolo riflettente, forma essenziale e pura, accoglie il riflesso senza imporsi, abitando con discrezione lo spazio. La cornice, con la sua superficie tridimensionale e materica, valorizza il vetro attraverso una micro-texture creata ad hoc, che amplifica la densità tattile del materiale e invita lo sguardo a perdersi nei dettagli.

Istante è uno specchio che invita alla contemplazione, diventando testimone dell'identità, del tempo e dello spazio che abitiamo. Un'architettura dello sguardo, che raccoglie tracce della nostra presenza restituendole come un ricordo appena emerso. Come una fotografia istantanea, lo specchio restituisce il presente e al tempo stesso ne suggerisce la memoria, configurandosi come un intreccio sottile di identità, tempo e spazio che abitiamo. La collezione si sviluppa in formati differenti, ciascuno pensato per attivare relazioni specifiche con lo spazio e con chi li osserva.

Istante transforms the idea of a captured moment into an object of glass, where those who gaze into it become the protagonists of their everyday lives. A reflecting rectangle, with its essential and pure form, welcomes the reflection without imposing itself, inhabiting the space with subtlety. The frame, with its three-dimensional, tactile surface, enhances the glass through a bespoke micro-texture that amplifies the material's tactile depth and invites the eye to linger on the details.

Istante is a mirror that encourages contemplation, becoming a witness to identity, time, and the space we inhabit. An architecture of the gaze, it collects traces of our presence and returns them as a memory just surfaced. Like an instant photograph, the mirror reflects the present while suggesting memory, forming a delicate interplay of identity, time, and space.

The collection is available in different sizes, each designed to engage specific relationships with the space and with those who observe it.

**istante**  
Gupica



Smoked glass frame.  
54 x 3 x 86 cm  
72 x 3 x 86 cm



Bronze glass frame.  
Green glass frame.  
68 x 3 x 180 cm



Bronze glass frame.  
108 x 3 x 130 cm



Nata dalla memoria del cosmo – dalla polvere di stelle, dalla gravità, dall'impatto – la collezione Asteroids esplora l'origine celeste della materia e la sua trasformazione in una quiete assoluta.

Ogni tavolino afferma una presenza fisica forte, innegabile. Il piano si posa su due elementi scultorei in vetro, dando vita a un dialogo tra equilibrio e gravità. Queste forme verticali non sono semplici sostegni, ma ancora monolitiche nello spazio, capaci di mantenere la superficie in uno stato di silenziosa armonia.

La luce scorre sui volumi solidi, si diffonde lungo i bordi e rivela sottili variazioni di texture e riflesso.

Il tavolino appare come radicato nel suo ambiente, assorbendo e trattenendo lo spazio circostante. A seconda dell'ora del giorno e dell'angolazione dello sguardo, cattura l'attenzione mutando tra ombra e forma, sempre intensamente presente.

La collezione Asteroids parla di origine e trasformazione – di solido che si fa liquido, di liquido che si fa forma, di forma che si fa sostanza.

È un'esplorazione di geometrie essenziali e densità materica, dove funzione e scultura convergono in un unico silenzioso gesto.

Born from the memory of the cosmos – from stardust, gravity, and impact – the Asteroids collection explores the celestial origin of matter and its transformation into pure stillness.

Each table asserts a bold, undeniable physical weight. The tabletop rests on two sculptural glass elements, creating a dialogue between balance and gravity.

These vertical forms act not only as supports but as monolithic spatial anchors, holding the surface in a state of quiet equilibrium.

Light plays across the solid volumes, diffuses along the edges, and reveals subtle variations in surface texture and reflection.

The table grounds its environment, absorbing and anchoring the space around it. Depending on the time of day and the angle of view, it commands attention, shifting in shadow and form, always profoundly present.

The Asteroids collection speaks of origin and transformation – of earth becoming liquid, of liquid becoming form, of form becoming substance.

It is an exploration of essential geometry and material density, where function and sculpture converge in a single, quiet gesture.

asteroids

Arik Levy



Fused glass base and top,  
Brilliant Mud back-painted.  
109 x 114 x H30 cm

Fused glass base, Brilliant Mud  
back-painted; Mystic Brown marble top.  
109 x 114 x H35 cm

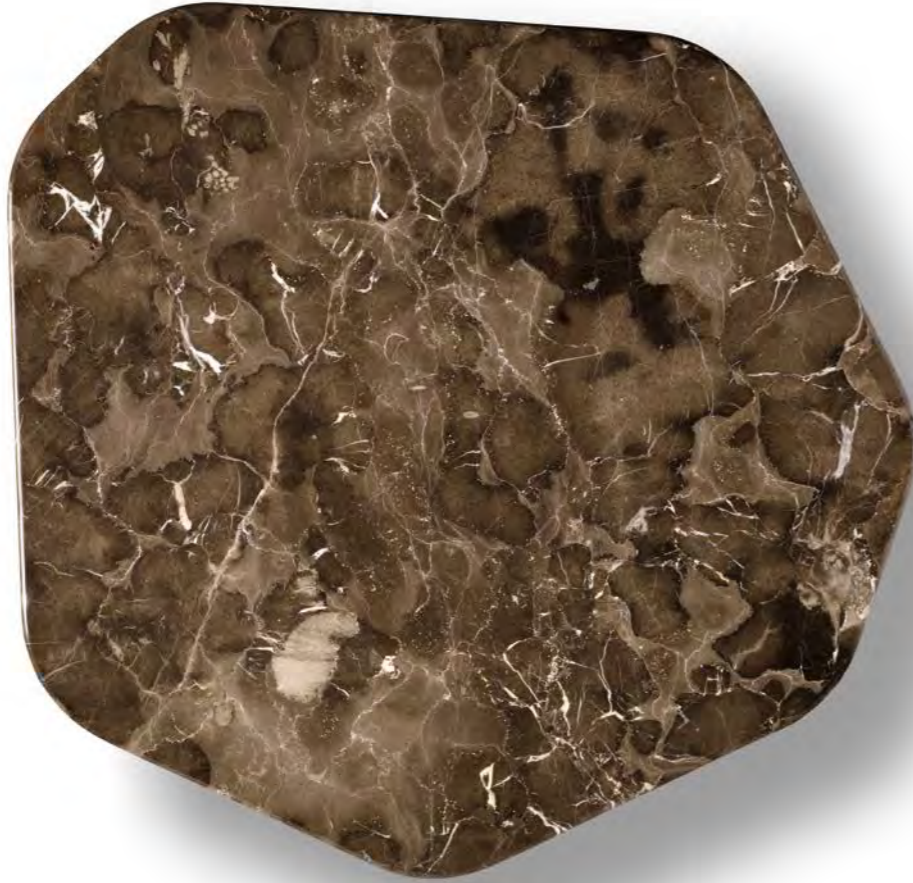

Mystic Brown marble top.  
109 x 114 x H35 cm



Fused glass base and top,  
Brilliant Brown back-painted.  
109 x 114 x H30 cm

Fused glass base and top,  
Copper Brown back-painted.  
109 x 114 x H35 cm



Fused glass base and top,  
Brilliant Mud back-painted.  
109 x 114 x H30 cm

Fused glass base, Brilliant Mud back-painted;  
Calacatta Royal marble top.  
109 x 114 x H35 cm

Il sistema di contenitori progettato da Studio Klass per Fiam nasce dalla ricerca di un nuovo equilibrio tra materiali, geometrie e funzionalità. Elemento centrale del progetto è il frame sottile ed essenziale, studiato per alleggerire visivamente la struttura e dare risalto ai materiali. Questa cornice architettonica racchiude le superfici con leggerezza, creando un raffinato gioco di volumi sospesi e valorizzando il contrasto tra la solidità del top e la trasparenza delle ante.

L'armonia tra pieni e vuoti, unita alla pulizia formale, conferisce al sistema un'eleganza discreta e una leggerezza visiva che lo rendono adatto a tutti gli ambienti contemporanei.

This cupboard designed by Studio Klass for Fiam stems from the pursuit of a new balance between materials, geometries, and functionality. At the heart of the project lies a slim, essential frame, conceived to visually lighten the structure and enhance the materials. This architectural framework encloses the surfaces with a sense of lightness, creating a refined interplay of suspended volumes and highlighting the contrast between the solidity of the top and the transparency of the doors.

The harmony between solid and void, combined with a clean, formal aesthetic, conveys to the system a discreet elegance and visual lightness, making it suitable for all contemporary interiors.



segesta bar  
Studio Klass



Moka lacquered external structure; bronze glass doors;  
Mystic Brown marble top.  
115 x 41 x H146 cm - VERSION WITH DRAWERS.



Moka lacquered external structure; bronze glass doors;  
Mystic Brown marble top.  
115 x 41 x H146 cm - VERSION WITH REFRIGERATOR.



Vulcano Grey lacquered external structure;  
smoked glass doors;  
Carrara Grey marble top.  
115 x 41 x H146 cm - VERSION WITH DRAWERS

Onair è una poltrona che bilancia presenza e assenza, volume e leggerezza. Progettata con eleganza garbata e discreta, si integra perfettamente in qualsiasi ambiente, completando lo spazio senza essere invadente. Le gambe sono sostituite dal vetro curvo caratteristico di Fiam Italia, creando una separazione visiva tra la seduta e il pavimento. Questo aumenta la sensazione di galleggiamento, come se la poltrona fosse sospesa in aria. Questa sottile interazione di forma solida e trasparenza conferisce a ONAIR una presenza che è allo stesso tempo definita e sfuggente, tangibile ma eterea, dove il comfort incontra l'illusione di leggerezza.

Onair is an armchair that balances presence and absence, volume and lightness. Designed with refined elegance and discretion, it seamlessly integrates into any setting, completing the space without being intrusive. Instead of traditional legs, ONAIR features FIAM Italia's signature curved glass, creating a visual separation between the seat and the floor that enhances the sense of floating, as if the armchair was suspended in mid-air. This subtle interplay of solid form and transparency gives ONAIR a presence that is both defined and elusive, tangible yet ethereal, where comfort meets the illusion of weightlessness.



Curved glass base;  
Teddy Bear fabric upholstery,  
01/2 Sabbia color.  
80 x 62 x H65 cm

**onair**  
Ceriani Szostak



Curved bronze glass base;  
Chestnut Brown Nubuck upholstery.  
80 x 62 x H 65 cm

# ogiva

Francesca Lanzavecchia

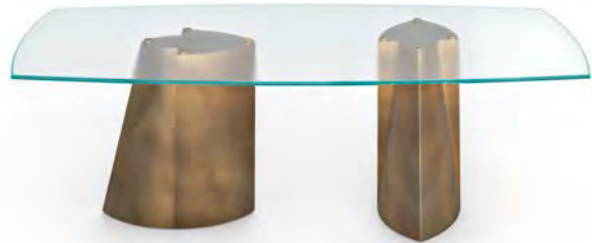

Tavolo con basi in metallo, disponibili verniciate con tinte metallizzate, spatolate in Ecomalta, oppure finite con finiture metalliche premium. Piano sagomato con forma "a botte" in vetro da 15 mm fuso a gran fuoco e temperato, disponibile trasparente o retroverniciato con tinte metallizzate. Il piano è disponibile anche in vetro standard o extralight da 15 mm temperato, oppure in vetro bronzo o fumé da 16 mm stratificato e bisellato. Piano disponibile anche in marmo spessore 20 mm.

Table with metal bases, available laquered with metallic colours, or hand-finished with Ecomalta, or with premium metal finishes. Top made of 15 mm "barrel" shaped glass, fused and tempered, available transparent or back-painted with metallic colours. The top is available also in 15 mm tempered standard or extralight glass, or in 16 mm bronze or smoked glass, layered and bevelled. The top is available also in marble, 20 mm thick.

## Base in metallo verniciato Lacquered metal base

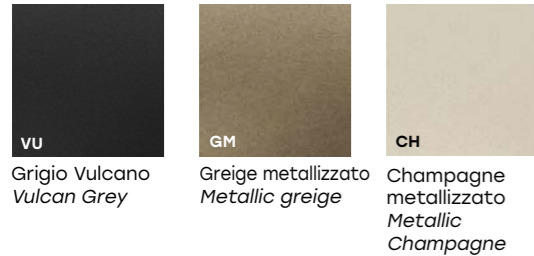

## Base in metallo spatolata in Ecomalta® Ecomalta® hand-finished metal base



## Base in metallo finitura Premium Premium finish metal base

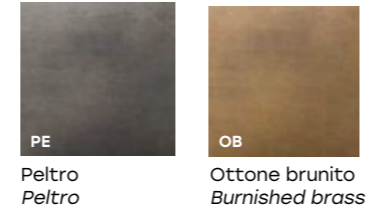

## Piano in vetro temperato \_ Tempered glass top



## Piano in vetro stratificato \_ Layered glass top

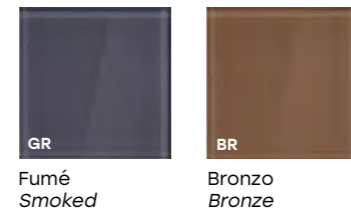

## Piano in vetro fuso \_ Fused glass top



## Piano in marmo \_ Marble top

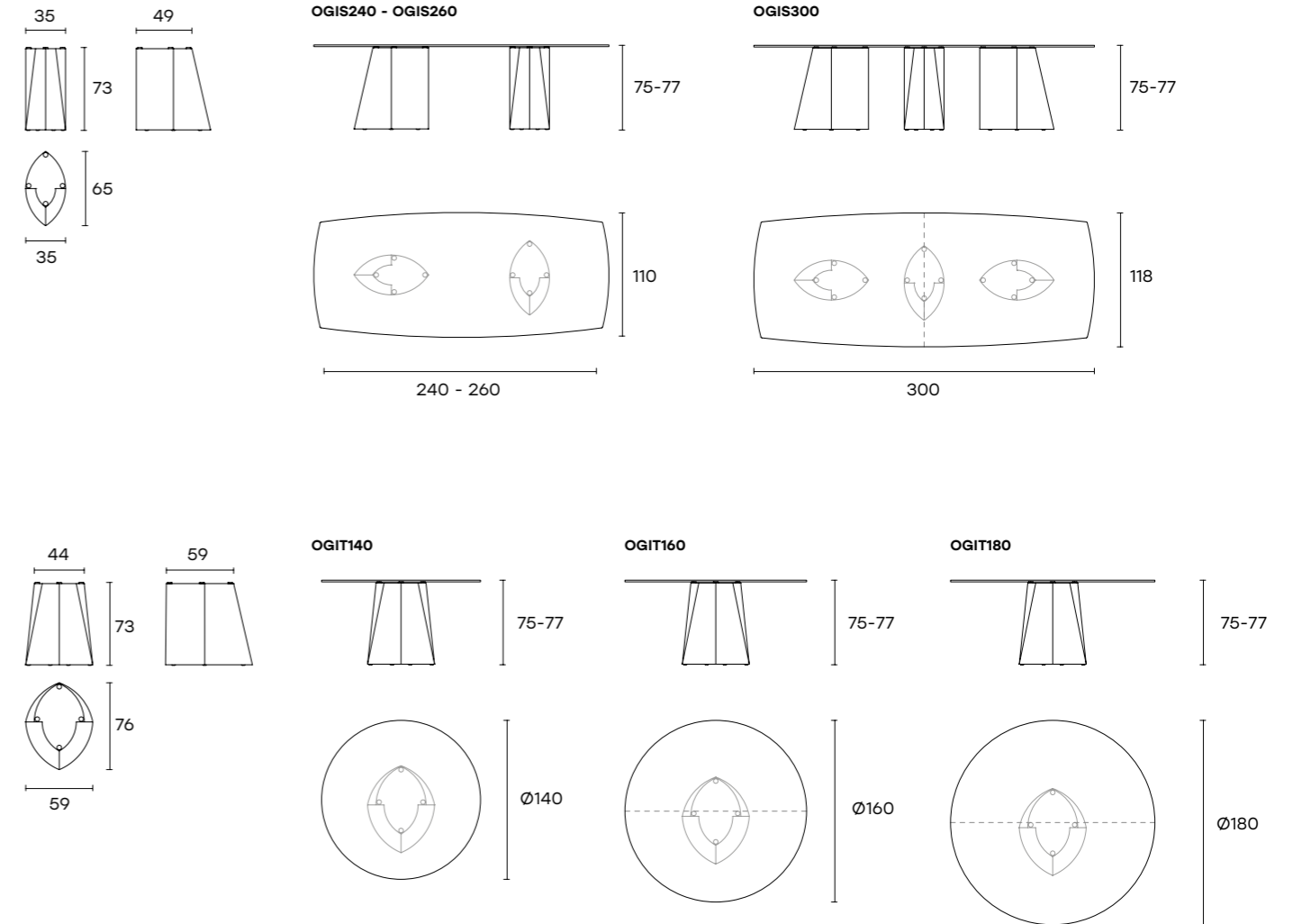
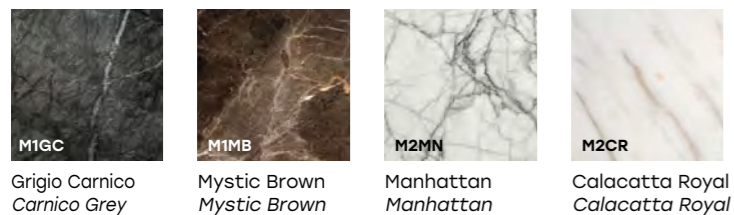

Sagomato/Shaped  
L 240 x P 110 x H 75 cm  
L 94 1/2" x W 43 5/16" H 29 1/2"  
L 260 x P 110 x H 75 cm  
L 102 3/8" x W 43 5/16" H 29 1/2"  
L 300 x P 118 x H 75 cm  
L 78 3/4" x W 46 7/16" H 29 1/2"

Tondo/Round  
Ø 140 x H 75 cm  
Ø 55 1/8" x H 29 1/2"  
Ø 160 x H 75 cm  
Ø 63 1/8" x H 29 1/2"  
Ø 180 x H 75 cm  
Ø 70 7/8" x H 29 1/2"

# trivium

Meneghella Paoletti



Tavolo con basi in legno massello e vetro fuso a gran fuoco, disponibili in diverse finiture. Piano in vetro da 15 mm fuso a gran fuoco e temperato, disponibile trasparente o retroverniciato con tinte metallizzate. Il piano è disponibile anche in vetro standard o extralight da 15 mm temperato, oppure in vetro bronzo o fumé da 16 mm stratificato e bisellato. Piano disponibile anche in legno impiallacciato spessore 40 mm.

Table with bases made of solid wood and fused glass, available in various finishes. Top made of 15 mm fused and tempered glass, available transparent or back-painted with metallic colours. The top is available also in 15 mm tempered standard or extralight glass, or in 16 mm bronze or smoked glass, layered and bevelled. The top is available also in veneered wood, 40 mm thick.

## Base - Parte in legno massello Base - Solid wood part



NE  
Nero  
Black

TA  
Tabacco  
Tobacco

## Base - Parte in vetro fuso Base - Fused glass part

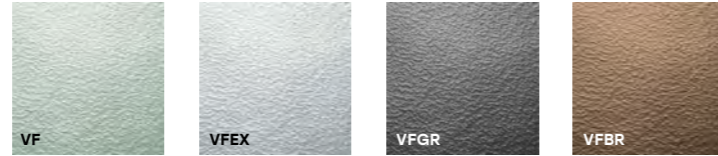

VF  
Standard  
Standard

VFEX  
Extralight  
Extralight

VFGR  
Fumé  
Smoked

VFBR  
Bronzo  
Bronze

## Piano in legno \_ Wood top



NE  
Noce Canaletto  
tinto Nero  
Canaletto walnut,  
Black finish

TA  
Noce Canaletto  
tinto Tabacco  
Canaletto walnut,  
Tobacco finish

## Piano in vetro temperato Tempered glass top



SD  
Standard  
Standard

EX  
Extralight  
Extralight

## Piano in vetro stratificato Layered glass top



GR  
Fumé  
Smoked

BR  
Bronzo  
Bronze

## Piano in vetro fuso \_ Fused glass top

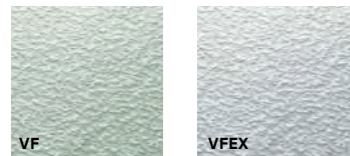

VF  
Standard  
Standard

VFEX  
Extralight  
Extralight

## Piano in vetro fuso retroverniciato \_ Fused and back-painted glass top

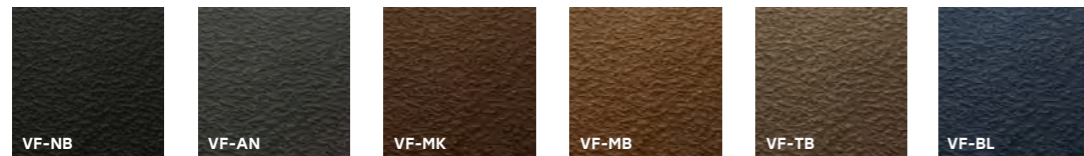

VF-NB  
Retroverniciato  
Grigio Antracite  
Anthracite Grey  
back-painted

VF-AN  
Retroverniciato  
Grigio Antracite  
Anthracite Grey  
back-painted

VF-MK  
Retroverniciato  
Moka  
Moka  
back-painted

VF-MB  
Retroverniciato  
Marrone Brillante  
Brilliant Brown  
back-painted

VF-TB  
Retroverniciato  
Terra Brillante  
Brilliant Mud  
back-painted

VF-BL  
Retroverniciato  
Blu Notte  
Night Blue  
back-painted

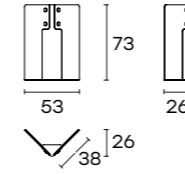

TRIR200

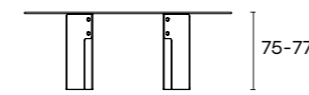

200

TRIR240

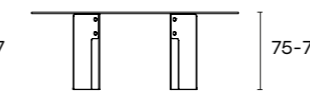

240

TRIR260

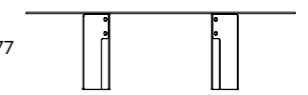

260

TRIR300

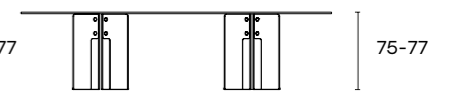

300

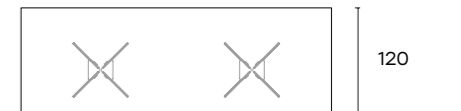

TRIT140

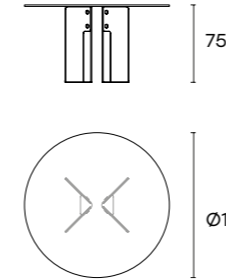

TRIT160

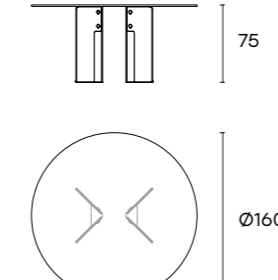

TRIT180

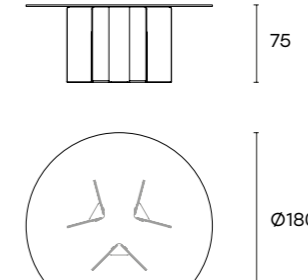

## PIANO LEGNO WOOD TOP

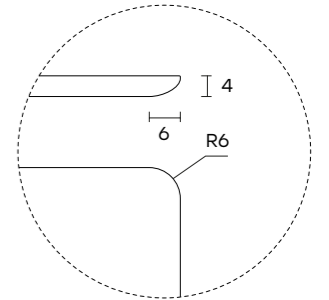

## Rettangolare/Rectangular

L 200 x P 100 x H 75 cm  
78 3/4" x W 39 3/8" H 29 1/2"  
L 240 x P 110 x H 75 cm  
94 1/2" x W 43 5/16" H 29 1/2"  
L 260 x P 110 x H 75 cm  
102 3/8" x W 43 5/16" H 29 1/2"  
L 300 x P 120 x H 75 cm  
118 1/8" x W 47 1/4" H 29 1/2"

## Tondo/Round

Ø 140 x H 75 cm  
Ø 55 1/8" x H 29 1/2"  
Ø 160 x H 75 cm  
Ø 63 1/8" x H 29 1/2"  
Ø 180 x H 75 cm  
Ø 70 7/8" x H 29 1/2"

# brenta

Simone Bonanni



Sedia con struttura in legno massello disponibile nelle finiture Tabacco o laccato Nero a poro aperto. Seduta e schienale rivestiti in pelle One o Nubuck.

Chair with solid wood structure, available in Tobacco or in open pore Black laquered finish. Seat and backrest are upholstered in leather One or Nubuck.

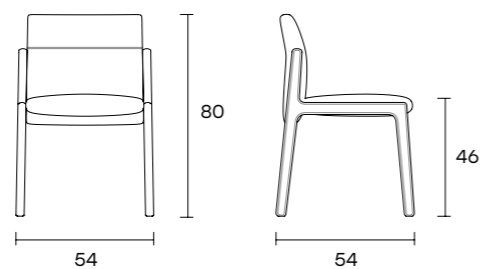

L 54 x P 54 x H 80 cm  
L 21 1/4" x W 21 1/4" H 31 1/2"

## Struttura in legno Wood structure



NE  
Nero  
Black

TA  
Tabacco  
Tobacco

## Rivestimento in pelle One One leather upholster

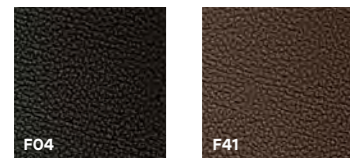

F04  
Nero  
Black

F41  
Testa di Moro  
Dark Brown

## Rivestimento in Nubuck Nubuck upholster

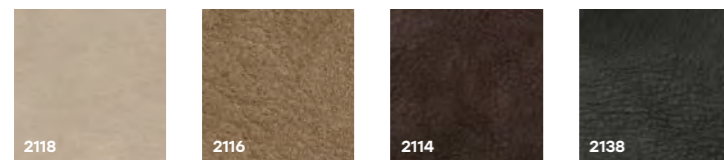

2118  
Perla  
Pearl Grey

2116  
Castagna  
Chestnut Brown

2114  
Testa di Moro  
Dark Brown

2138  
Lavagna  
Slate Black

# still

Controvento



Specchio da parete con cornice in vetro da 6 mm fuso a gran fuoco e retroargentato, disponibile nelle finiture standard, bronzo o fumè. specchio piano da 5 mm. Telaio posteriore in metallo verniciato. Possibilità di appendimento in diverse posizioni.

Wall mirror with 6 mm-thick high-temperature fused and back-silvered glass frame, available in standard, bronze or smoked finishes. 5 mm-thick flat mirror. Painted metal rear frame. It can be hung in various positions.

ST1200

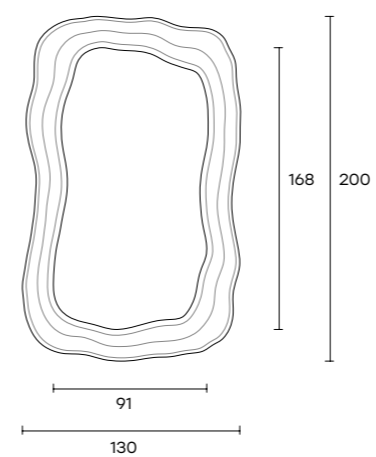

L 130 x P 10 x H 200 cm  
L 51 3/8" x W 4" H 78 3/4"  
L 150 x P 10 x H 150 cm  
L 59" x W 4" H 59"  
Ø 130 x P 10 cm  
Ø 51 3/16" x W 4"

ST1150

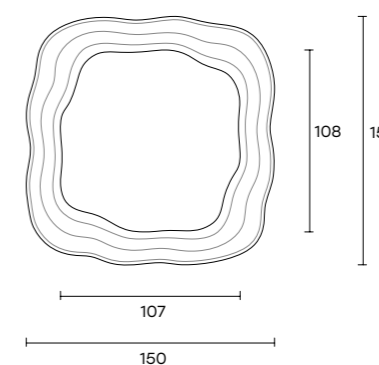

ST1130

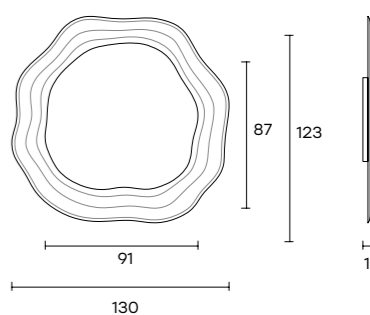

## Cornice in vetro fuso \_ Fused glass frame



AG  
Vetro standard  
retroargentato  
Back-silvered  
standard glass

GR-AG  
Vetro fumè  
retroargentato  
Back-silvered  
smoked glass

BR-AG  
Vetro bronzo  
retroargentato  
Back-silvered  
bronze glass

# istante

Gupica



Specchio da parete con cornice in vetro da 6 mm fuso a gran fuoco, disponibile trasparente nelle finiture bronzo, fumè o verde. La cornice è disponibile anche in vetro fuso retroverniciato con tinte metallizzate. Specchio piano da 5 mm. Telaio posteriore in metallo.

Wall mirror with 6 mm-thick high-temperature fused glass frame, available transparent in bronze, smoked or green finishes. Frame available also in back-painted fused glass, with metallic paints. 5 mm-thick flat mirror. Metal rear frame.

IST54

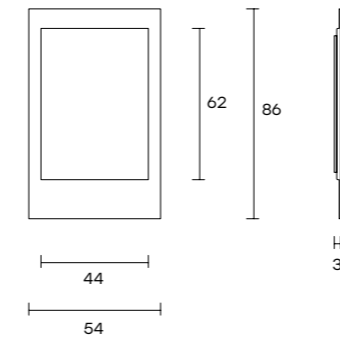

IST72

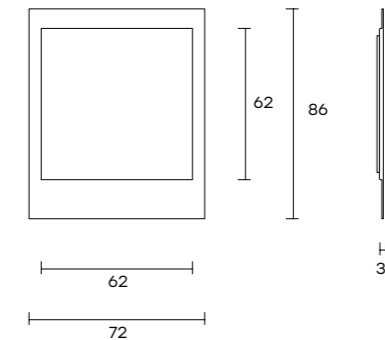

IST108

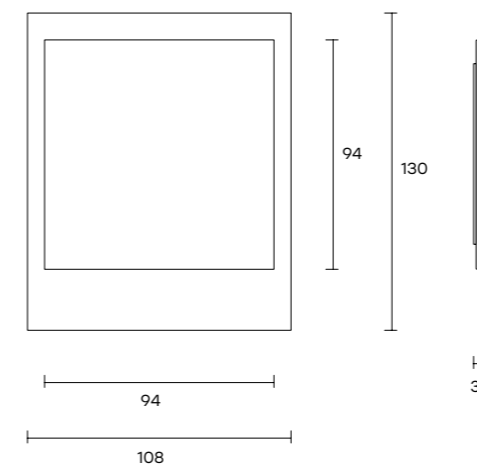

IST68

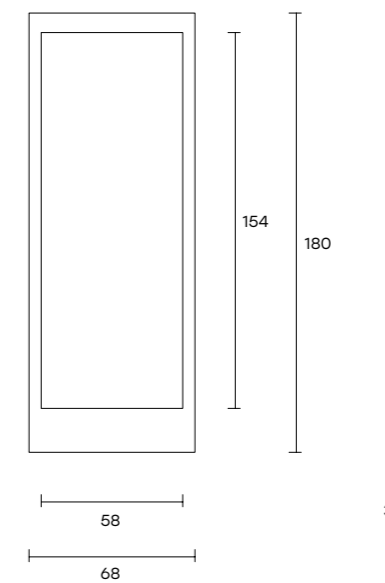

## Cornice in vetro fuso Fused glass frame

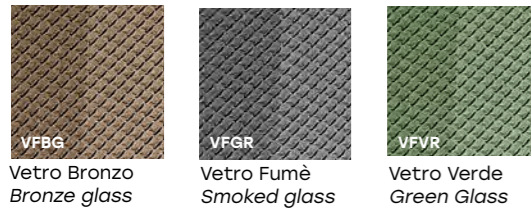

## Cornice in vetro fuso retroverniciato Fused and back-painted glass frame

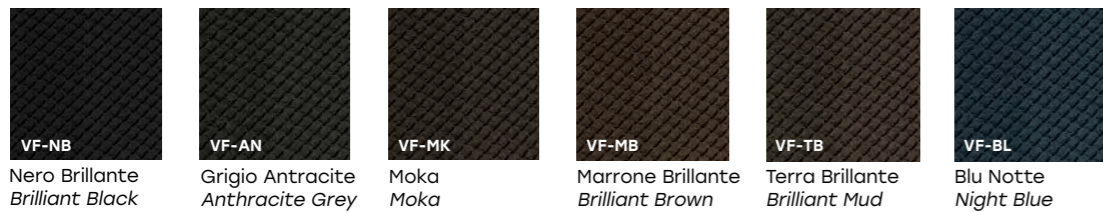

L 54 x P 3 x H 86 cm  
L 21 1/4" x W 1 3/16" H 33 7/8"  
L 72 x P 3 x H 86 cm  
L 28 3/8" x W 1 3/16" H 33 7/8"  
L 108 x P 3 x H 130 cm  
L 42 1/2" x W 1 3/16" H 51 3/16"  
L 68 x P 3 x H 180 cm  
L 26 3/4" x W 1 3/16" H 70 7/8"

# asteroids

Arik Levy



Tavolino con piano sagomato in vetro da 10 mm fuso a gran fuoco, retroverniciato con tinte metallizzate. Base in vetro da 10 mm fuso a gran fuoco e curvato, retroverniciato con tinte metallizzate in tinta con il piano. Piano disponibile anche in marmo, spessore 20 mm.

Coffee table with shaped top in 10 mm high-temperature fused glass, back-painted with metallic colours. Base in 10 mm high-temperature fused and curved glass, back-painted with metallic colours matching the top. Top also available in marble, 20 mm thick.

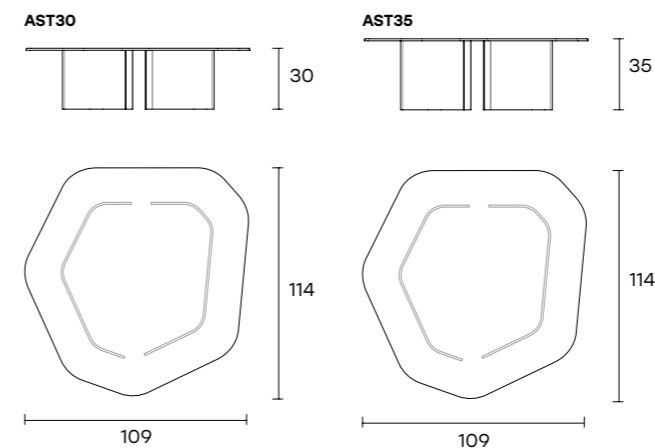

L 114 x P 109 x H 30 cm  
L 44 7/8" x W 43" H 11 13/16"  
L 114 x P 109 x H 35 cm  
L 44 7/8" x W 43" H 13 3/4"

Piano e base in vetro fuso retroverniciato \_ Fused and back-painted glass top and base

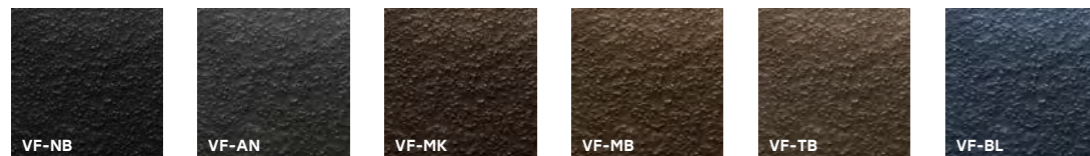

VF-NB  
Nero Brillante  
Brilliant Black

VF-AN  
Grigio Antracite  
Anthracite Grey

VF-MK  
Moka  
Moka

VF-MB  
Marrone Brillante  
Brilliant Brown

VF-TB  
Terra Brillante  
Brilliant Mud

VF-BL  
Blu Notte  
Night Blue

FINITURE NON STANDARD  
SU RICHIESTA  
NON-STANDARD FINISHES  
ON REQUEST



VF-RA  
Marrone Ramato  
Copper Brown



VF-CH  
Champagne  
Champagne



VF-SA  
Verde Salvia  
Sage Green



VF-CI  
Cipria  
Powder Pink

Piano in marmo \_ Marble top

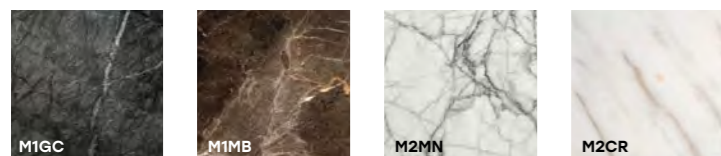

M1GC  
Grigio Carnico  
Carnico Grey

M1MB  
Mystic Brown  
Mystic Brown

M2MN  
Manhattan  
Manhattan

M2CR  
Calacatta Royal  
Calacatta Royal

# segesta bar

Studio Klass



Madia con scocca esterna in legno laccato Grigio Vulcano, Greige Metallizzato, oppure Moka. Top in legno laccato in tinta con la struttura esterna (spessore 14 mm), oppure in Marmo (spessore 40 mm), oppure in legno impiallacciato (spessore 40 mm). Base e piedini in acciaio verniciato nero. Ante in vetro da 6 mm temperato nelle varianti liscio, fuso oppure acidato, disponibili in diverse finiture e verniciature. I vetri delle ante sono fissati ad un telaio di alluminio in finitura nera, con cerniere a scomparsa. Struttura interna in nobilitato a trama plissettata, attrezzata con: ripiano in vetro da 12 mm temperato; ripiano portabottiglie in legno; frigorifero da 50L, di cui 3,6L adibiti a cella freezer. Il frigorifero è sostituibile da un sistema di 3 cassetti. Sistema di illuminazione a LED integrato nella struttura interna (opzionale).

Cupboard with external structure in lacquered wood in Vulcan Grey, Metallic Greige, or Moka finish. Top available in the same lacquered wood finish of the external structure (14 mm thick), or in marble (40 mm thick), or in veneered wood (40 mm thick). Base and feet in black lacquered metal. Relevant doors in flat, fused or acid-etched tempered glass (6 mm. thick), available in various finishes and lacquers. The glass doors are fastened to an aluminium frame in black finish through hidden hinges. Internal structure in pleated-texture melamine, equipped with: a 12 mm tempered glass shelf; a wooden bottle rack shelf; a 50 L refrigerator, including a 3.6 L freezer compartment. The refrigerator can be replaced with a system of 3 drawers. Optional LED lighting system integrated within the internal structure.

SEF115  
con frigorifero / with refrigerator

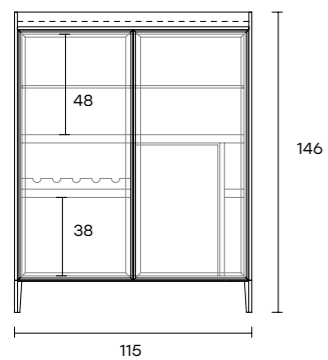

SEC115  
con cassetti / with drawers

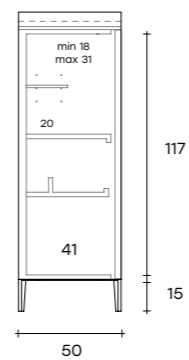
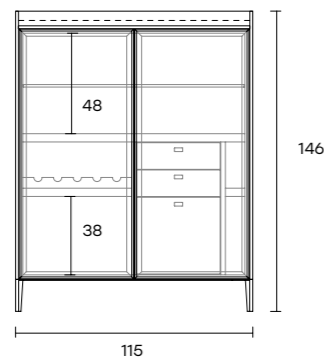

L 115 x P 50 x H 145 cm  
L 45 1/4" x W 19 1/16" H 57"

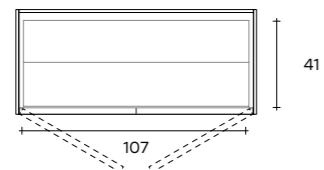
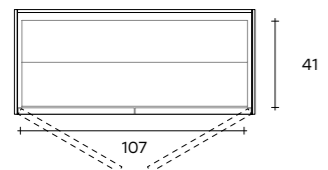

## Scocca esterna e top in legno laccato \_ External structure and top in laquered wood

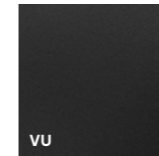

VU  
Grigio Vulcano  
Vulcan grey

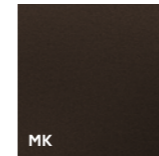

MK  
Moka metallizzato  
Metallic Moka

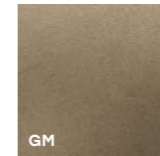

GM  
Greige metallizzato  
Metallic greige

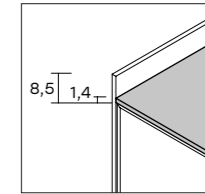

## Ante in vetro piano \_ Flat glass doors

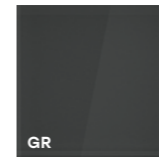

GR  
Fumè  
Smoked

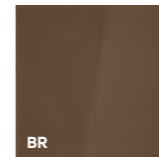

BR  
Bronzo  
Bronze

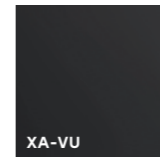

XA-VU  
Extralight acidato  
retroverniciato  
Grigio Vulcano  
Acid-etched  
extralight,  
Vulcan Grey back-  
back-painted

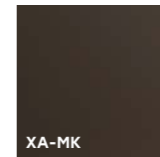

XA-MK  
Extralight acidato  
retroverniciato  
Moka  
Acid-etched  
extralight, Moka  
back-painted

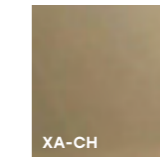

XA-CH  
Extralight acidato  
retroverniciato  
Champagne  
Acid-etched  
extralight, Champagne  
back-painted

## Ante in vetro fuso \_ Fused glass doors

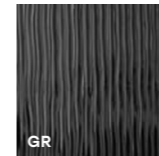

GR  
Fumè  
Smoked

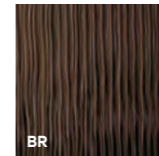

BR  
Bronzo  
Bronze



XA-VU  
Retroverniciato  
Grigio Vulcano  
Vulcan Grey  
back-painted

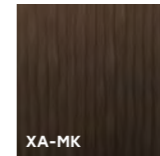

XA-MK  
Retroverniciato  
Moka  
back-painted

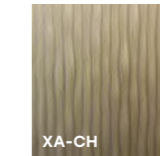

XA-CH  
Retroverniciato  
Champagne  
back-painted

## Top in marmo \_ Marble top

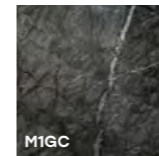

M1GC  
Grigio Carnico  
Carnico Grey



M1MB  
Mystic Brown  
Mystic Brown

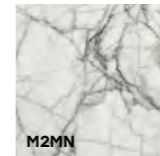

M2MN  
Manhattan  
Manhattan

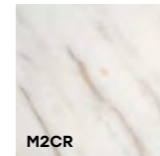

M2CR  
Calacatta Royal  
Calacatta Royal

## Top in legno impiallacciato \_ Veneered wood top



TN  
Termotrattato  
Nero  
Heat-treated  
Black finish

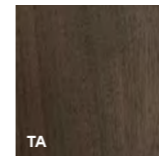

TA  
Noce Canaletto  
tinto Tabacco  
Canaletto Walnut  
Tobacco finish



NC  
Noce Canaletto  
Canaletto Walnut

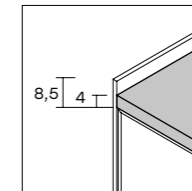

# onair

Ceriani Szostak



Poltroncina con struttura interna in legno multistrato. Imbottitura di seduta e schienale in poliuretano. Base in vetro curvato da 10 mm. Piedini in alluminio in finitura spazzolato oppure anodizzato nero. La poltroncina può essere rivestita in pelle o in tessuto: fare riferimento alle categorie di rivestimento disponibili. Struttura sfoderabile solo nelle versioni in tessuto.

Armchair with internal structure in multilayered wood. Seat and back cushion in polyurethane. Curved glass base, 10 mm thick. Aluminium feet in brushed or black finish. The armchair can be upholstered in leather or fabric, please refer to the available upholstery categories. Structure is removable in fabric versions only.

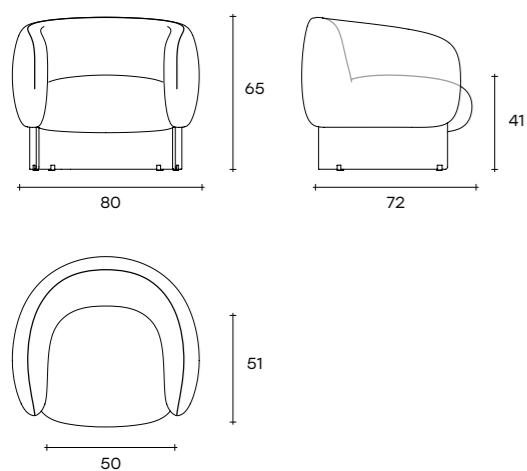

L 80 x P 72 x H 65 cm  
L 31 1/2" x W 28 3/8" H 25 9/16"

Base in vetro curvato (su richiesta) \_ Curved glass base (on request)



Vetro extralight  
Extralight glass

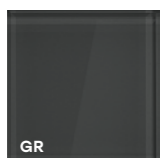

Vetro fumé  
Smoked glass

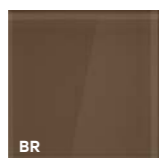

Vetro bronzo  
Bronze glass

## pelli / leathers

### SILKY

cat. PL-2

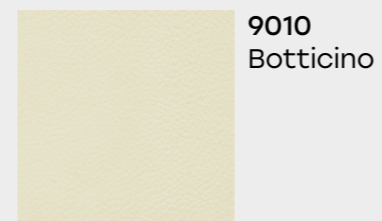

9010  
Botticino

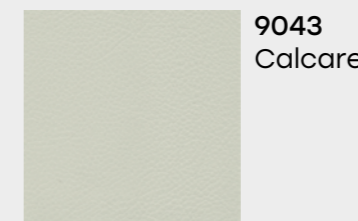

9043  
Calcare

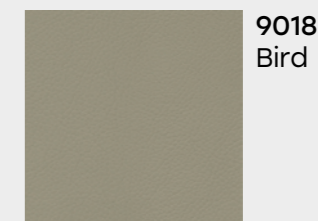

9018  
Bird

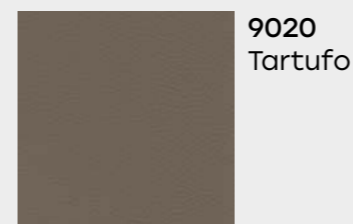

9020  
Tartufo



9032  
Fondente

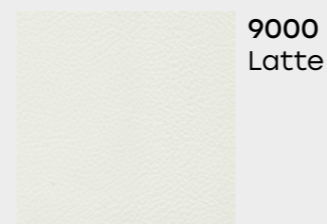

9000  
Latte

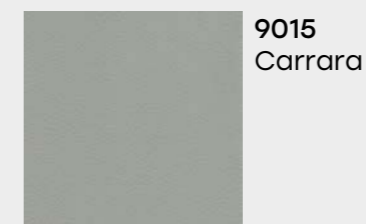

9015  
Carrara

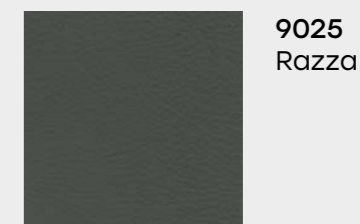

9025  
Razza

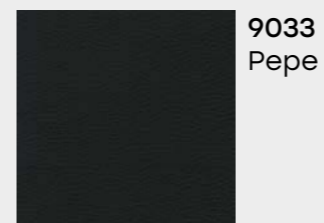

9033  
Pepe

### NUBUCK

cat. PL-5

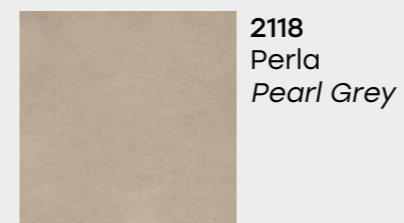

2118  
Perla  
Pearl Grey

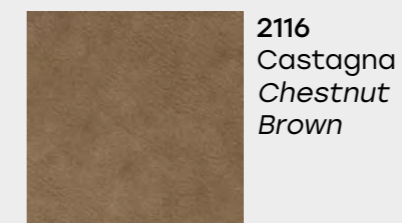

2116  
Castagna  
Chestnut  
Brown

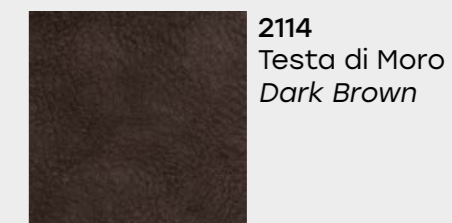

2114  
Testa di Moro  
Dark Brown

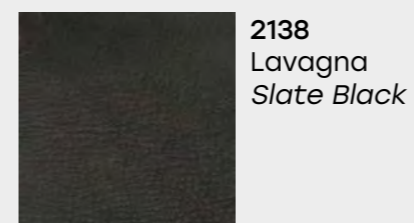

2138  
Lavagna  
Slate Black

# tessuti / fabrics

## STARLIGHT

cat. TX-2



## MOONLIGHT

cat. TX-2



# tessuti / fabrics

## BOUCLÉ

cat. TX-3

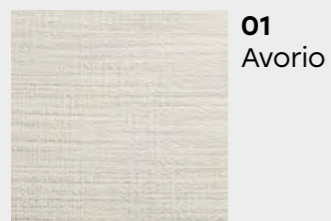

**01**  
Avorio

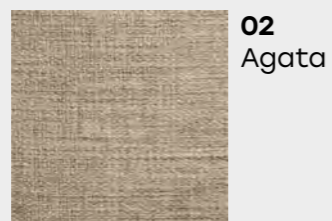

**02**  
Agata

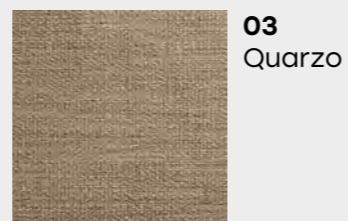

**03**  
Quarzo

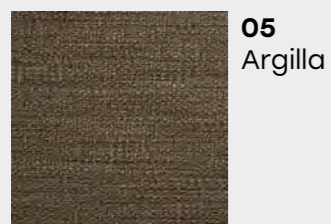

**05**  
Argilla

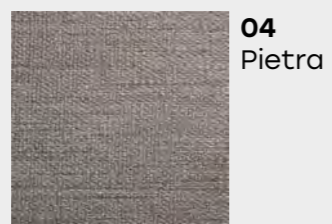

**04**  
Pietra

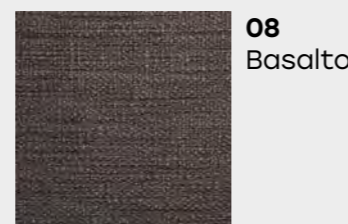

**08**  
Basalto



**09**  
Ardesia

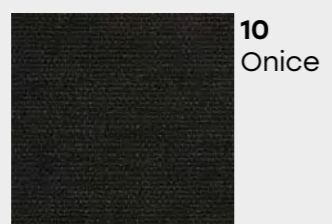

**10**  
Onice

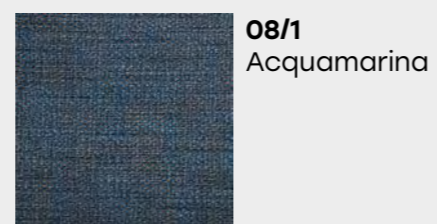

**08/1**  
Acquamarina

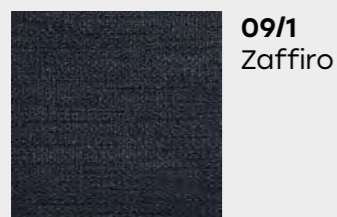

**09/1**  
Zaffiro

## TEDDY BEAR

cat. TX-4

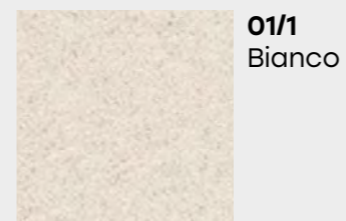

**01/1**  
Bianco

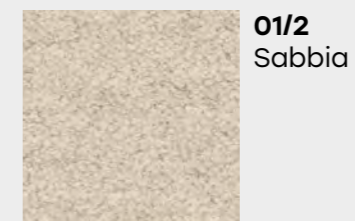

**01/2**  
Sabbia

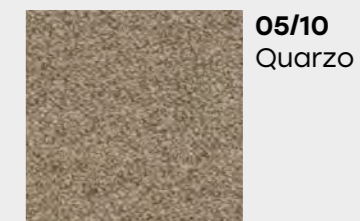

**05/10**  
Quarzo

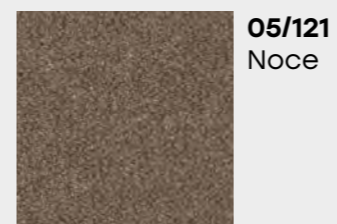

**05/121**  
Noce

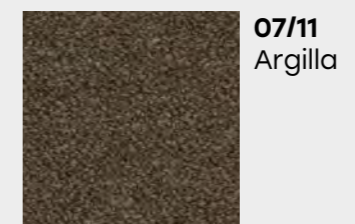

**07/11**  
Argilla

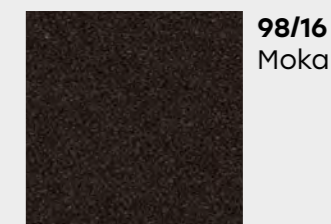

**98/16**  
Moka

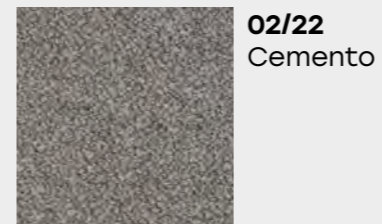

**02/22**  
Cemento

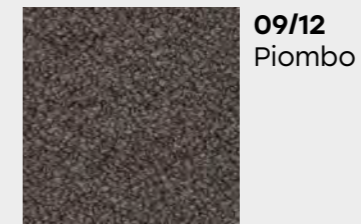

**09/12**  
Piombo



**98/21**  
Antracite

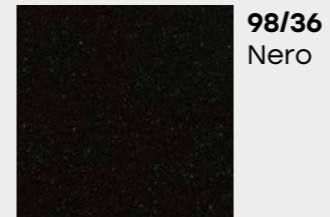

**98/36**  
Nero

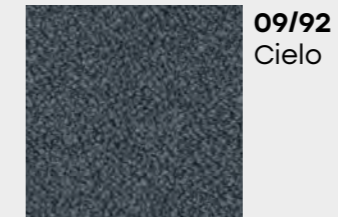

**09/92**  
Cielo



**98/20**  
Blu Notte

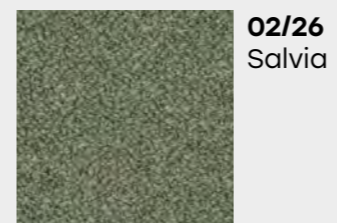

**02/26**  
Salvia



**98/18**  
Foresta

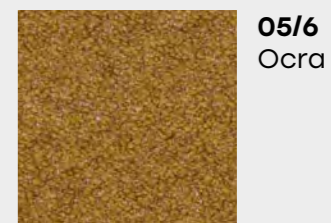

**05/6**  
Ocra



**07/24**  
Ruggine

**art direction**  
adele martelli

**graphic design**  
acanto comunicazione

**photography and post production**  
studio leon

**rendering images**  
reality studio  
controvento

**marketing project**  
daniele livi

**coordination and logistics**  
lorenzo marzoli

April 2026

**Fiam Italia**  
Via Ancona 1/b  
61010 Tavullia (PU)  
Italy

T: +39 0721 20051  
F: +39 0721 202432  
info@fiamitalia.it

#fiamitalia

follow us on



[fiamitalia.it](http://fiamitalia.it)