

POP
LOLLIPOP

MARCEL
WANDERS

MAGMA

PATRICK
JOUIN

RIME

BARTOLI
DESIGN

LANDS

STUDIO
KLASS

04-2017
NEW ITEMS

FIAM

NEW ITEMS 2017

2.



pop

DESIGN
MARCEL WANDERS

8.



lollipop

DESIGN
MARCEL WANDERS

10.



magma

DESIGN
PATRICK JOUIN

18.



rime

BARTOLI DESIGN

22.



lands

DESIGN
STUDIO KLASS

NEW FINISHES 2017

28.



LLT wood

DESIGN DANTE O. BENINI
E LUCA GONZO

32.



plié

DESIGN
STUDIO KLASS

36.



epsylon

DESIGN
FABIO DI BARTOLOMEI

38.



macramè

DESIGN
LUCIDIPEVERE

40.



quadra

DESIGN
MATTEO NUNZIATI

42.



rialto tris

DESIGN
CRS FIAM

44.



inori

DESIGN
SETSU E SHINOBU ITO



Compasso d'Oro
alla carriera

LEO
NAR
DO

Premio Leonardo
Qualità Italia 2015

pop

DESIGN MARCEL WANDERS

Specchio con cornice in vetro fuso a gran fuoco da 6 mm retroargentato; specchio piano da 5 mm. Telaio posteriore in metallo verniciato. Possibilità di appendimento verticale od orizzontale.

Wall mirror in 6 mm high temperature fused glass, back-silvered; 5 mm flat mirror. Rear frame in painted metal. It can be hung horizontally or vertically.

Pop è un'innovativa collezione di specchi firmati Marcel Wanders per FIAM, azienda italiana di arredo in vetro di fama mondiale. Spingendo i limiti dei processi artigianali e industriali, Pop esplora nuove tecniche per la lavorazione dello specchio, per creare l'illusione di una superficie dura che diventa morbida.

Pop is an innovative collection of transformed mirrors by Marcel Wanders for world-renowned Italian glass furniture company FIAM. Pushing elemental craftsmanship and industrial processes boundaries, Pop explores new techniques for mirror glass treatment to create the illusion of a hard surface becoming soft.



“Come designer, la sperimentazione è essenziale per il nostro metodo. Cercare modi per fare ciò che non è mai stato fatto prima, è per questo che siamo qui.”

“As designers, experimentation is essential to our process. Looking for ways to do what's never been done before, that's why we're here.”

Marcel Wanders

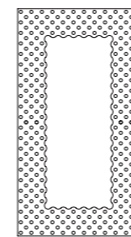

L 116 P 5 H 216 cm
W 45 11/16" D 2" H 85"

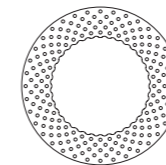

∅ 148 P 5 cm
∅ 58 1/4" P 12"

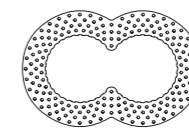

L 169 P 5 H 109 cm
W 66 9/16" D 2" H 43"



pop

DESIGN MARCEL WANDERS

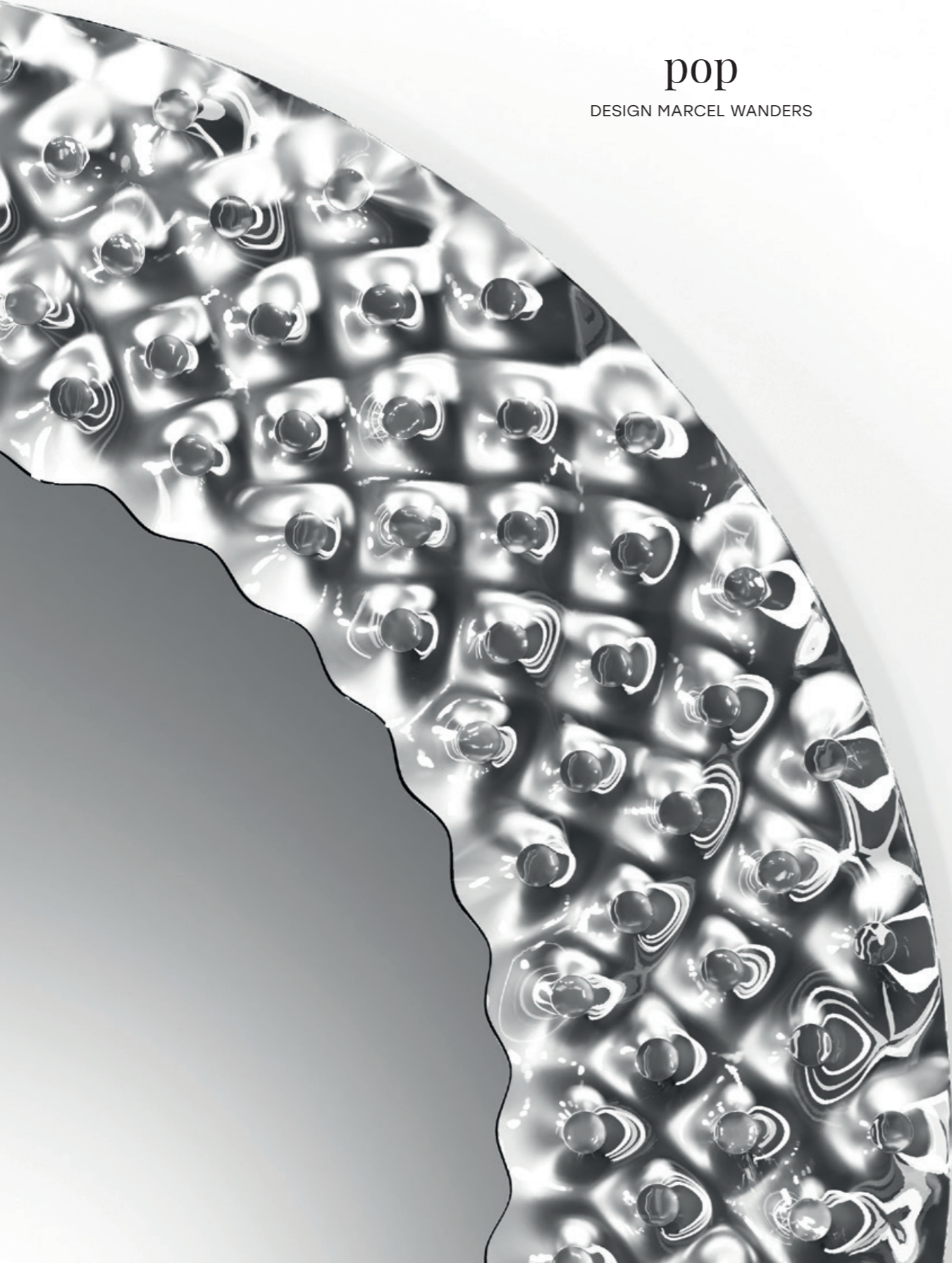

pop

DESIGN MARCEL WANDERS



lollipop

DESIGN MARCEL WANDERS



Specchio da parete in vetro fuso da 8 mm retro argentato, specchio piano da 5 mm.

Wall mirror in 8 mm-thick fused and back-silvered glass; 5 mm-thick flat mirror.

Lollipop è un eclatante specchio di grandi proporzioni. La sua forma iconica non è solo memorabile, ma contiene in sé qualità narrative che donano personalità e carattere distintivo ad ogni ambiente living.

Lollipop is an eye-catching statement mirror piece of enlarged proportions. Its iconic shape is not only memorable but has also built-in storytelling qualities, giving distinctive character and personality to any living environment.



L 200 P 10 H 90 cm
W 78 3/4" D 4" H 35 7/16"

magma

DESIGN PATRICK JOUIN



Tavolo con piano in vetro extralight da 15 mm fuso a gran fuoco, disponibile nelle tinte trasparenti Fumo, Blu o Ambra. Struttura in legno rovere disponibile nelle finiture naturale o tinto grigio.

Table with 15 mm extralight fused glass top, available in Smoke grey, Blue or Amber finish. Oak structure available in natural or grey finish.

Prodotta nel 2015, la vetrina Aura ha segnato l'inizio della collaborazione tra Patrick Jouin e FIAM. Il risultato di una ricerca congiunta nel campo delle tecnologie per la cottura e il taglio del vetro, il tavolo Magma sembra quasi ammorbidire il materiale. Tenuto su una struttura di base in rovere naturale o affumicato, il tavolo è costituito da una lastra di vetro fuso, cotto due volte in uno stampo. Durante la cottura, la struttura naturale dello stampo segna il vetro, producendo un effetto grafico interessante. Anche se la sua produzione rimane industriale, il tavolo Magma fa virtù delle sue imperfezioni. La tecnica sviluppata da Patrick Jouin e adottata da FIAM consente la produzione di pezzi unici che utilizzano una tecnologia industriale.

Produced in 2015, the Aura display cabinet marked the start of the collaboration between Patrick Jouin and glass manufacturers FIAM. The result of joint research into technologies for firing and cutting glass, the Magma table almost seems to soften the material. Held on a natural or smoked oak base structure, the tabletop is made of a sheet of fused glass, fired twice in a mould. During firing, the natural texture of the mould marks the glass, producing an interesting graphic effect. Although its production remains industrial, the Magma table makes virtue of its imperfections. The technique developed by Patrick Jouin and mastered by FIAM enables the production of one-off pieces using industrial technology.

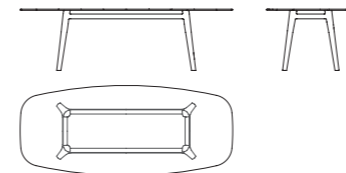

L 260 P 110 H 75 cm
W 102 3/8" D 43 5/16" H 29 1/2"

L 220 P 106 H 75 cm
W 86 5/8" D 41 3/4" H 29 1/2"

Struttura Structure



legno rovere
naturale
natural oak

legno rovere
tinto grigio
grey finish oak

Piano in vetro Glass top



fumo
smoke grey

blu
blue

ambra
amber

Top in vetro ambra
Base in rovere tinto grigio
Amber glass top
Grey finish oak base



magma

DESIGN PATRICK JOUIN



Top in vetro blu
Base in rovere tinto grigio
Blue glass top
Grey finish oak base

magma

DESIGN PATRICK JOUIN



Top in vetro blu
Base in rovere naturale
Blue glass top
Natural oak base

magma

DESIGN PATRICK JOUIN

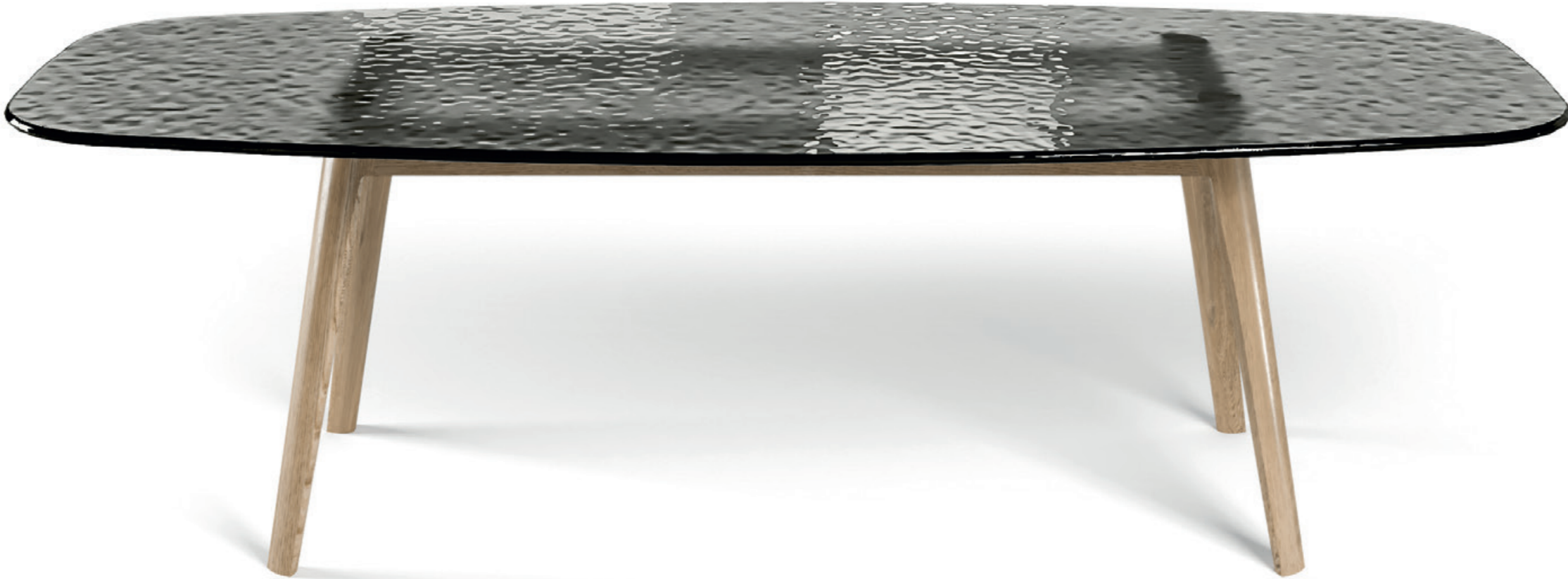

Top in vetro fumè
Base in rovere naturale
Smoked glass top
Natural oak base



Top in vetro fumè
Base in rovere tinto grigio
Smoked glass top
Grey-finish oak base

rime

BARTOLI DESIGN



Tavolo fisso o allungabile con piano in vetro da 15mm ed allunghe in vetro da 12mm, disponibile in diverse finiture: vetro extralight acidato retroverniciato bianco, nero o grigio; vetro trasparente spatolato a mano con Ecomalta ad effetto materico, disponibile in diversi colori: Avorio TBP, Tortora TNR, Nero Ardesia. Basamento composto da elementi in vetro extralight da 15 mm fuso a gran fuoco.

Fix or extendible table with 15 mm glass top and 12 mm glass extensions, available in various finishes: white, black or grey back-painted etched extralight glass; transparent glass hand-finished with Ecomalta for a textured effect, available in various colours: Ivory TBP, Dove-grey TNR, Black Slate. 15 mm extralight fused glass base.



Top ecomalta tortora TNR
Base in vetro extralight
Dove grey TNR ecomalta top
Extralight glass base

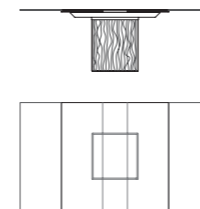

L 130 (230) P 130 H 75 cm
W 51 3/16" (90 9/16") D 51 3/16" H 29 1/2"

L 146 (236) P 146 H 75 cm
W 57 1/2" (93") D 57 1/2" H 29 1/2"

Un volume essenziale costituisce la base del tavolo Rime: la sua superficie mutevole, trasparente ed opaca allo stesso tempo, appare come cristallizzata in un monolite di ghiaccio. Rime è una famiglia di tavoli fissi ed allungabili con base volumetrica in vetro extra chiaro fuso a stampo, con top in vetro satinato extrachiaro retro-verniciato nei colori bianco, grigio e nero. Disponibile anche con top in vetro con finitura materica nei colori avorio, grigio tortora e nero ardesia.

The Rime table has a simple shaped base, the surface of which changes. It is both transparent and opaque as if it were crystallised in a block of ice. Rime is a collection of fixed and extendible tables supported by an extra-clear, fused glass block base with an extra-clear, back-painted, satin-finish glass top in white, grey and black. Also available with a textured finish glass top in ivory, dove grey and slate black.



Piano in vetro extralight retroverniciato
Back-painted extralight glass top



bianco
white

nero
black

grigio
grey

Piano in vetro trasparente spatolato con Ecomalta
Transparent glass finished with Ecomalta



avorio TBP
ivory TBP

tortora TNR
dove-grey TNR

nero ardesia
black slate

rime

BARTOLI DESIGN



Top ecomalta tortora TNR
Base in vetro extralight
Dove grey TNR ecomalta top
Extralight glass base

lands

DESIGN STUDIO KLASS



Top in pietra grey
Basi in vetro ambra
Pietra grey top
Amber glass base



Top in pietra grey
Basi in vetro ambra
Pietra grey top
Amber glass base

Top in glam bronze
Basi in vetro fumè
Glam bronze top
Smoked glass base



Top in venus
Basi in vetro ambra
Venus top
Amber glass base

Top in vetro
retroverniciato nero
Basi in vetro fumè
Black back-painted
glass top
Smoked glass base

Collezione di tavolini composti da piano in vetro extralight da 6 mm retroverniciato nero, oppure in gres da 6 mm disponibile in diverse finiture. Il piano è applicato ad un pannello strutturale bordato da una fascia verniciata finitura rame satinato. Basi in vetro soffiato artigianalmente disponibili nelle finiture fumè o Ambra.

Collection of coffee tables consisting of 6 mm, black back-painted extralight glass top or in 6 mm stoneware available in various colours. The top is set on a structured panel edged with a painted band, with a satin copper finish. Hand-blown glass base, available in smoked or Amber finish.

Lands è una collezione di coffee-table e side-table ispirata alle viste aeree dei terreni rurali, caratterizzati da diverse forme e cromie in base al tipo di coltivazione. La disposizione dei terreni, apparentemente casuale, genera affascinanti composizioni cromatiche e formali a cui si richiama la collezione Lands, composta da tavolini di diverse forme e altezze pensati per essere affiancati e posizionati in base alle esigenze, sia per utilizzo singolo che per essere combinati a isole. In base a forma e dimensione, i tavolini sono composti da due o tre basi in vetro soffiato con top in vetro retro-verniciato o con top in pietra, in entrambi i casi accompagnato da una bordatura in rame.

Lands is a collection of coffee and side tables inspired by aerial views of rural landscapes, featuring different shapes and colours, based on the type of cultivation. The seemingly haphazard layout of the land creates fascinating compositions of colour and shapes which are echoed in the Lands collection. The collection includes coffee and side tables of different sizes and shapes, designed to be grouped or positioned as required, either individually or in combinations to create islands. Based on shape and size, the tables feature two or three bases in blown glass with tops in back-painted glass or stone, both of which are edged in copper.

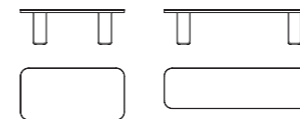

L 90 P 45 H 30 cm
W 35 7/16" D 17 11/16" H 11 13/16"

L 90 P 45 H 40 cm
W 35 7/16" D 17 11/16" H 15 3/4"

L 130 P 35 H 30 cm
W 51 3/16" D 13 3/4" H 11 13/16"

L 130 P 35 H 40 cm
W 51 3/16" D 13 3/4" H 15 3/4"

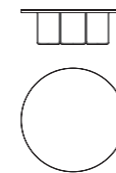

Ø 90 H 30 cm
Ø 35 7/16" H 11 13/16"

Ø 120 H 30 cm
Ø 47 1/4" H 11 13/16"

Ø 120 H 40 cm
Ø 47 1/4" H 15 3/4"

Basi in vetro
Glass base



fumè
smoked

ambra
amber

Piano in vetro
Glass top



retroverniciato nero
black back-painted

Piano in gres
Stoneware top



venus

glam bronze

pietra grey

lands
DESIGN STUDIO KLASS





LLT wood

DESIGN DANTE O. BENINI
E LUCA GONZO



Top ecomalta argilla
Base vetro extralight
Clay brown ecomalta top
Extralight glass base

LLT wood

DESIGN DANTE O. BENINI
E LUCA GONZO



Top ecomalta argilla
Base vetro extralight
Clay brown ecomalta top
Extralight glass base

Tavolo con piano in legno multistrato marino da 40 mm impiallacciato noce canaletto, rovere "old" o rovere termotrattato, oppure in legno spatolato a mano con Ecomalta ad effetto materico, disponibile in diversi colori: Argilla, Fango M25, Calce M42. Struttura in vetro trasparente o extralight stratificato da 30 mm e gambe in vetro trasparente o extralight da 19 mm.

Table with top in 40 mm multilayered marine plywood veneered, canaletto walnut, "old style" oak finish or heat-treated oak finish, or in wood hand-finished with Ecomalta for textured effect, available in various colours: Clay brown, Mud brown M25, Lime grey M42. Structure in 30 mm layered glass, transparent or extralight and legs in 19 mm transparent or extralight glass.

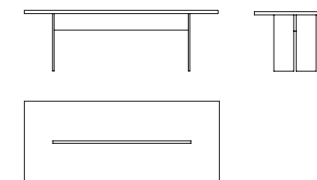

L 200 P 100 H 74 cm
W 78 3/4" D 39 3/8" H 29 1/8"
L 240 P 100 H 74 cm
W 94 1/2" D 39 3/8" H 29 1/8"
L 300 P 110 H 74 cm
W 118 1/8" D 43 5/16" H 29 1/8"

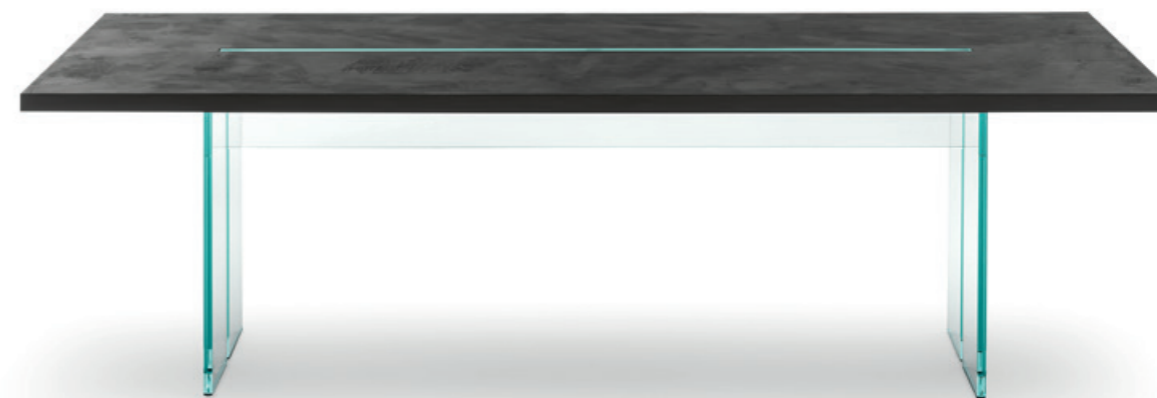

Piano in legno Plywood top



noce canaletto
canaletto walnut



rovere "old"
"old style"
oak finish



rovere
termotrattato
heat-treated
oak finish

Legno spatolato con Ecomalta Ecomalta hand-finished wood

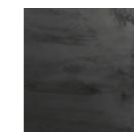

argilla
clay brown

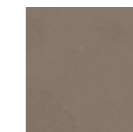

fango M25
mud brown M25



calce M42
lime grey M42

NUOVE FINITURE / NEW FINISHES

pliè

DESIGN STUDIO KLASS

Tavolo composto da due basi in vetro sagomato e curvato da 12 mm, disponibili in vetro fumè o extralight; piano disponibile in vetro extralight, oppure in legno impiallacciato finitura rovere termotrattato o finitura olmo, oppure in legno spatolato a mano con Ecomalta ad effetto materico, colore Argilla.

Table consisting of two 12 mm shaped and curved glass bases, available in smoked or extralight glass; top available in extralight glass, or in veneered wood with heat-treated oak or elm finish, or in wood hand-finished with Ecomalta for textured effect, clay brown.

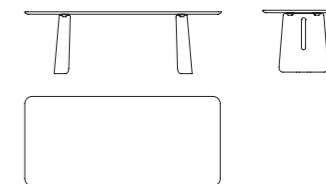

L 200 P 100 H 75 cm
 W 78 3/4" D 39 3/8" H 29 1/2"
 L 240 P 100 H 75 cm
 W 94 1/2" D 39 3/8" H 29 1/2"



Piano in legno
 Wood top



rovere
 termotrattato
 heat-treated
 oak finish



olmo
 elm finish
 NUOVA FINITURA
 NEW FINISHES

Legno spatolato con Ecomalta
 Ecomalta hand-finished wood

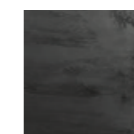

argilla
 clay brown
 NUOVA FINITURA
 NEW FINISHES

Top ecomalta argilla
 Base vetro fumè
 Clay brown ecomalta top
 Smoked glass base



Top finitura olmo
Base vetro extralight
Elm finish top
Extralight glass base

epsylon

DESIGN FABIO DI BARTOLOMEI

Tavolo con piano in vetro trasparente, extralight, o bronzo da 10 mm temperato. Struttura in acciaio finitura cromato oppure ottone brunito effetto nuvolato. Piastre di fissaggio in acciaio inox o in ottone. Il tavolo Epsilon è disponibile anche con piani su misura, diametro da 90 a 140 cm.

Table with 10 mm-thick tempered transparent, extralight or bronze glass top. Chromed or burnished brass finish legs; stainless steel or brass fixing plates. The Epsilon table is also available with customized top, diameter from 90 cm to 140 cm.

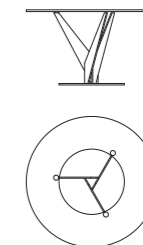

ø 120 H 75 cm
 ø 47 1/2" H 29 1/2"
 ø 140 H 75 cm
 ø 55 1/8" H 29 1/2"



Top vetro bronzo
 Base ottone brunito
 Bronze glass top
 Burnished brass legs

macramè

DESIGN LUCIDIPEVERE

Collezione di tavolini composti da una base in vetro filato intrecciato in maniera artigianale e da un piano di vetro da 10 mm.
La collezione di tavolini prevede le seguenti finiture: piano in vetro extralight con base in vetro extralight, piano in vetro bronzo con base verniciata bronzo, piano in vetro fumè con base verniciata fumè.

Collection of coffee tables comprising hand-interwoven spun glass base and 10 mm-thick glass top.
The coffee table collection includes the following finishes: extralight glass top with extralight glass base; bronze glass top with bronze painted base; smoked glass top with fumè grey painted base.

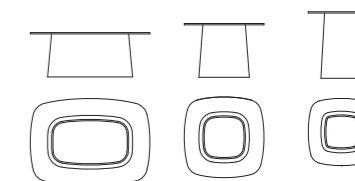

L 90 P 65 H 33 cm
W 35 7/16" D 25 9/16" H 12"

L 130 P 86 H 33 cm
W 51 3/16" D 33 7/8" H 12"

L 60 P 60 H 40 cm
W 23 5/8" D 23 5/8" H 15 3/4"

L 50 P 50 H 50 cm
W 19 11/16" D 19 11/16" H 19 11/16"



Vetro fumè
Smoked glass

quadra

DESIGN MATTEO NUNZIATI

Tavolino contenitore composto da 4 elementi in vetro curvato da 10 mm interposti tra 2 piani in vetro da 10 mm.
Piano superiore e divisori in vetro extralight; basi nelle seguenti varianti: vetro extralight trasparente, vetro extralight retroverniciato bianco, vetro extralight retroargentato, vetro bronzo retroargentato, vetro Nero95.

Coffee table/storage unit composed of 4 elements in 10 mm curved glass mounted between two 10 mm glass racks.
Top and partitions in extralight glass, bases available in extralight glass, extralight glass back-painted white, extralight mirrored glass, back-silvered bronze glass, black95 glass.

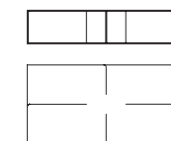

L 160 P 80 H 34 cm
W 32" D 31 1/2" H 13 3/8"



Base in vetro bronzo retroargentato
Back-silvered bronze glass base



rialto tris

DESIGN CRS FIAM



Composizione di tavoli bassi
in vetro curvato da 10 mm.
Disponibile anche in vetro
extralight, NERO 95
o in vetro bronzo retroargentato.
È possibile realizzare
Rialto tris su misura.

Set of coffee tables
in 10 mm-thick curved glass.
Also available in extralight glass,
Black 95 (NERO 95) glass
or back-silvered bronze glass
and in customized sizes.

	L 39,5 P 40 H 37,5 cm W 15 9/16" D 15 3/4" H 14 3/4"
	L 47,5 P 45 H 41,5 cm W 18 11/16" D 17 11/16" H 16 5/16"
	L 55,5 P 50 H 45,5 cm W 21 7/8" D 19 11/16" H 17 15/16"

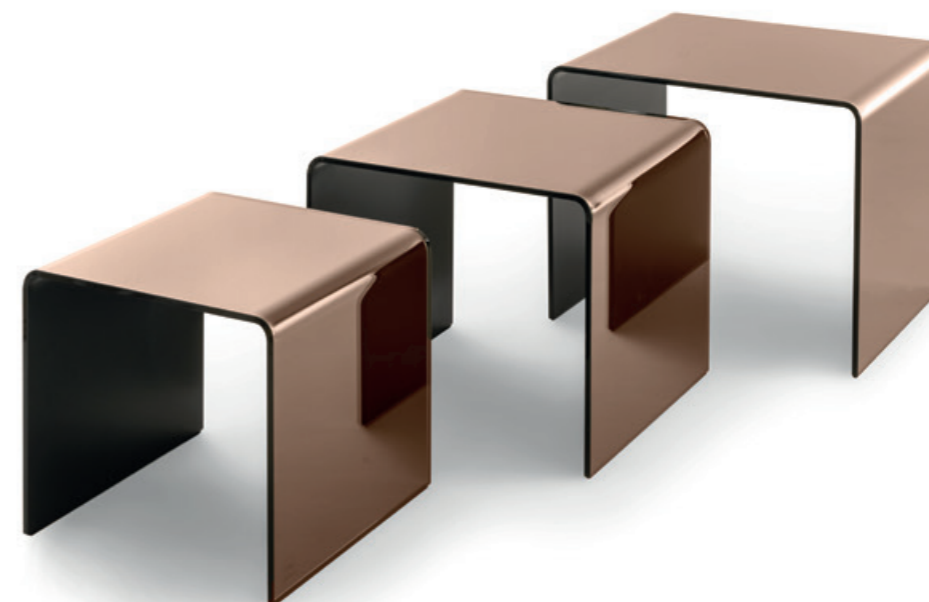

Vetro bronzo retroargentato
Back-silvered bronze glass

inori

DESIGN SETSU E SHINOBU ITO

Sistema composto da base e ripiani
in legno Rovere "Old";
montanti in vetro extralight da 12 mm.

System consisting of base
and shelves in "Old Style" oak;
uprights in 12 mm extralight glass.

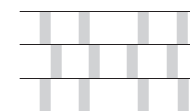

SPECCHI _ MIRRORS

pop
DESIGN
MARCEL WANDERS

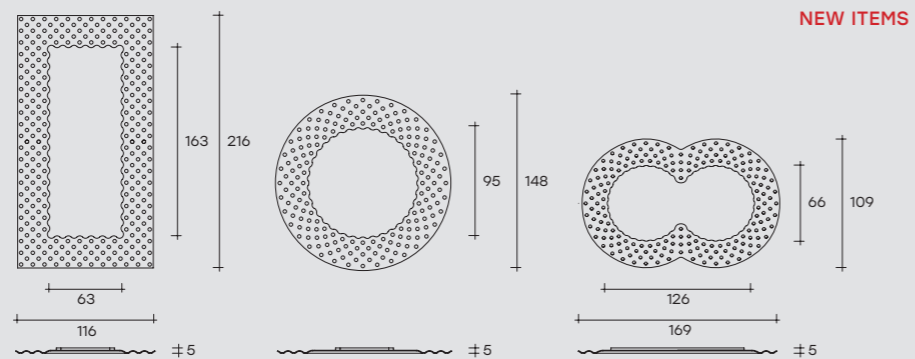

lollipop
DESIGN
MARCEL WANDERS

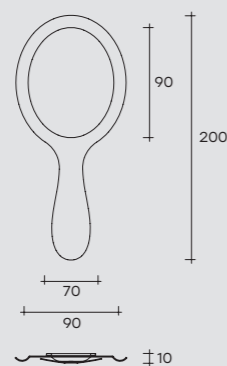

TAVOLI _ TABLES

magma
DESIGN
PATRICK JOUIN

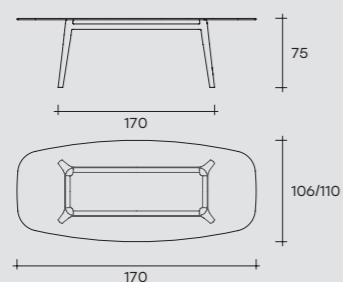

rime
BARTOLI DESIGN

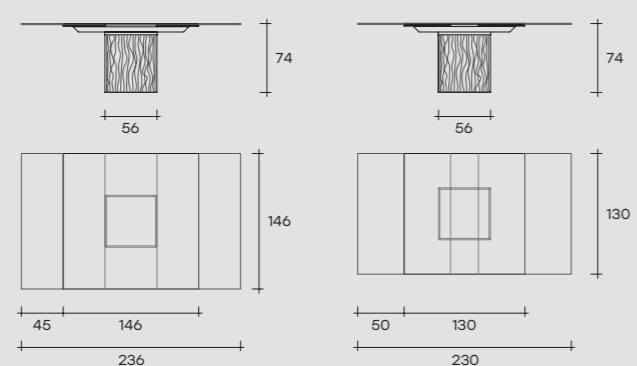

TAVOLI _ TABLES

plié
DESIGN
STUDIO KLASS



Top in legno / Wood top

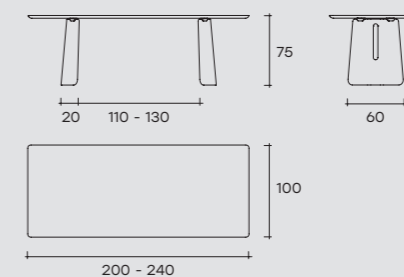

Top in vetro / Glass top

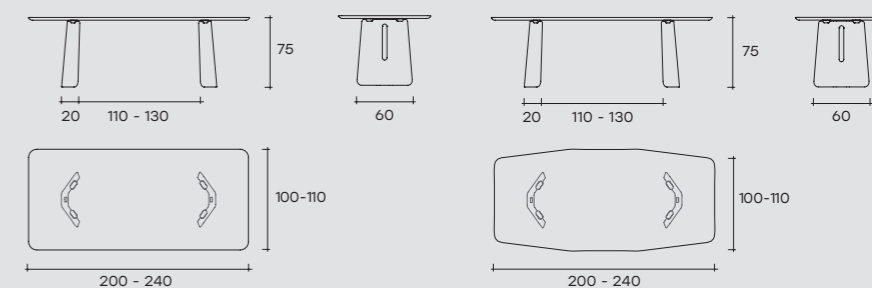

LLT wood
DESIGN DANTE O. BENINI
E LUCA GONZO

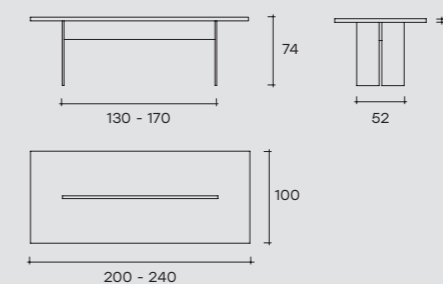

epsylon
DESIGN
FABIO DI BARTOLOMEI

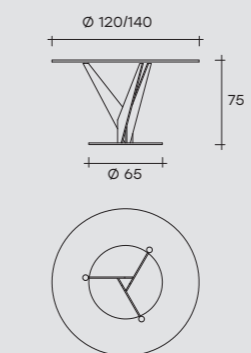

TAVOLI BASSI E DI SERVIZIO _ COFFEE TABLES AND SIDE TABLES

lands

DESIGN
STUDIO KLASS

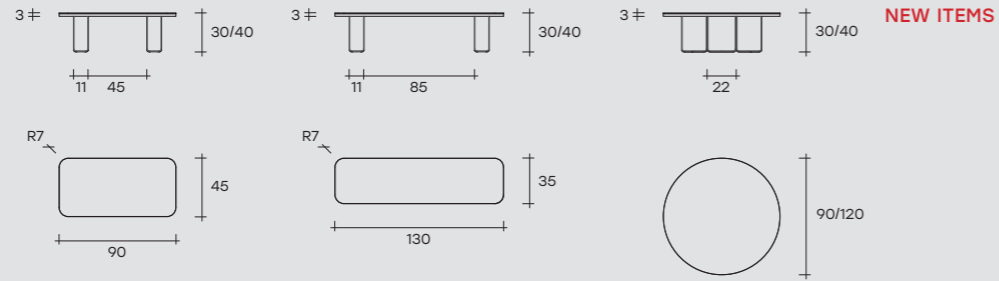

NEW ITEMS

quadra

DESIGN
MATTEO NUNZIATI

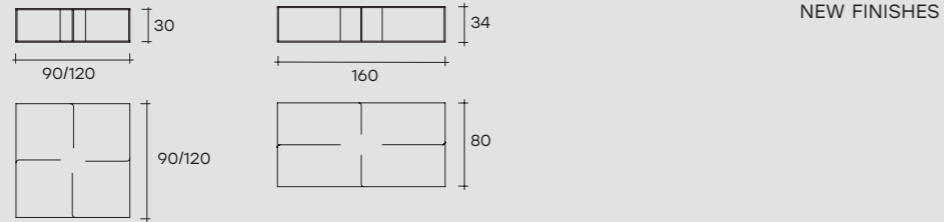

NEW FINISHES

rialto tris

DESIGN
CRS FIAM

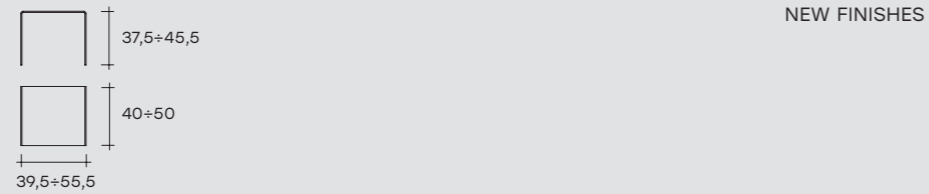

NEW FINISHES

macramè

DESIGN
LUCIDIPEVERE

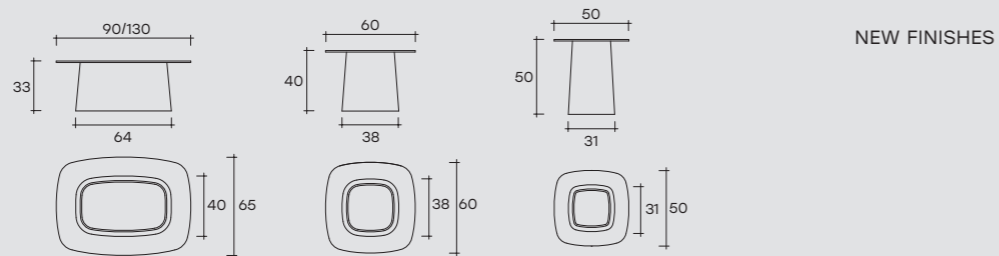

NEW FINISHES

LIBRERIA _ BOOKCASE

inori

DESIGN
SETSU
E SHINOBU ITO



Basi e ripiani
(spessore 40 mm)
Bases and shelves
(40 mm thick)

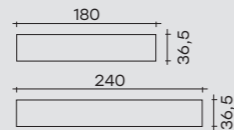

Montanti
Uprights

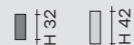

NEW FINISHES

art direction
acanto comunicazione
(carlo piazzesi)

graphic design and layout
acanto comunicazione
(katia fornaroli)

virtual images
acanto comunicazione
(p. 2, 4-5, 6-7, 8-9, 10,
12-13, 14-15, 16-17, 22,
24-25, 26-27, 32-33,
34-35, 38-39)

photography
studio leon
(p. 18, 20-21, 28-29,
30-31, 36-37, 40-41,
42-43, 44-45)

marketing project
daniele livi

coordination and logistics
lorenzo marzoli

selections
olimpia visual plan

print and packaging
grapho 5

Fiam Italia
Via Ancona 1/b
61010 Tavullia (PU), Italia
Tel. 0039 0721 20051
Fax: 0039 0721 202432

www.fiamitalia.it
info@fiamitalia.it

#fiamitalia

