

# URBAN HORIZONS

SALONE DEL MOBILE.MILANO 2024

SAMPLE ORDER

EN

**Kartell**  
Milano



Kartell has chosen a Milanese skyline for its stand at this year's Salone del Mobile. Milan is not just the city where Kartell has deep roots; it is also a city of excellence for creativity and a centre of CREATIVE INTELLIGENCE where universities, design studios, companies and customers come together to breathe life into the magical and irreplaceable machine that is Salone del Mobile.

The 2024 stand serves as a metaphor for Kartell's "Made in Milan" strategy and philosophy, and for the added value this brings in terms of creativity, internationalism, quality and future-orientation.

"Kartell Milano Urban Horizons" is not just the name of the stand concept; it concisely sums up the concept of our brand. It highlights the value Kartell assigns to architecture and the flexible way in which Kartell creates new living and work spaces with a coherent offering of products and settings that project a lifestyle of unique character.

This striking stand perimeter, reminiscent of the ancient Spanish walls that run around the historic city centre, contains Kartell's proposals for Salone del Mobile 2024. The stand entrance replicates that of Kartell's Milan flagship store (and therefore suggests those of all Kartell stores around the world). Inside, typically Milanese backdrops serve as surroundings for the latest collections, designs, additions to existing product lines and mini-settings.

This clever presentation conveys Kartell's vision of contemporary lifestyle and the personal creativity of the designers involved. The platforms on which the various products are arranged will soon reappear in the window displays of Kartell's stores, which serve as meeting places as well as shops and that naturally inspire dialogue between Kartell and its customers.

This series of settings that project Milan to the outside world as a virtual meeting point of horizons and cultures is the way in which Kartell has chosen to present itself at Salone del Mobile. The stand is populated by a rich catalogue of products ranging from tables to chairs and from lamps to sofas. Also on view is an extensive offering of Outdoor furnishings.

A great deal of attention has been paid to the choice of materials. Glass, aluminium, recycled polymers, fabrics and leather have all been selected for their circular supply chains and sustainable production processes. A large number of new fabrics, in indoor and outdoor colour variants, ensures a varied product assortment and makes personal combinations easy to put together.

Everything in the Salone's product selection has an easily interpreted and personalised look.

*Kartell disegna per il Salone del Mobile un orizzonte urbano che parte da Milano, come luogo nel quale l'azienda affonda le sue radici e spazio di eccellenza della creatività, centro di CREATIVE INTELLIGENCE dove università, studi di professionisti, imprese, clienti convergono per dare vita a quella magica e insostituibile macchina che è il Salone del Mobile.*

*Lo stand 2024 è metafora della strategia e filosofia di Kartell Made in Milano, con tutto il valore che porta questa scelta ovvero creatività, internazionalità, qualità e proiezione verso il futuro.*

*Kartell Milano Urban Horizons, questo il titolo del progetto allestitivo, ma anche la sintesi concettuale del marchio su uno sguardo profondo al valore dell'architettura e del suo modo poliedrico di ospitare al suo interno nuovi spazi di abitare e di lavoro e quindi l'impegno di creare un'offerta coerente di prodotti e di ambientazioni che disegnano un lifestyle dal carattere speciale.*

*All'interno del Perimetro espositivo, che evoca le mura spagnole che racchiudono il centro storico, sono rappresentate infatti le novità del Salone del Mobile 2024. L'ingresso è la riproduzione del portale del negozio Kartell a Milano (e idealmente dei tutti i negozi Kartell nel mondo) varcato il quale, con le scenografie di ambienti milanesi, si trovano esposte le nuove collezioni, i nuovi progetti, le implementazioni di alcune famiglie di prodotto e mini ambientazioni.*

*Questa soluzione allestitiva permette di raccontare la visione di Kartell, di un lifestyle contemporaneo e la creatività dei diversi designer attraverso il loro personale modo di progettare. Le pedane sulle quali sono rappresentati i prodotti, si ritroveranno nelle vetrine dei negozi Kartell che sono teatro di incontro, spazi che vivono oltre il prodotto, luoghi dove dialogare con il cliente e per il cliente.*

*Disegnare spazi internazionali che da Milano si proiettano in tutto il mondo in un incrocio virtuale di orizzonti e di culture è la modalità con la quale Kartell si presenta al Salone del Mobile con un ricco catalogo di proposte che spaziano dai tavoli alle sedute, dalle lampade ai divani fino ad arrivare ad una ampia offerta Outdoor.*

*Grande attenzione ai materiali che vanno dal vetro all'alluminio, dai materiali polimerici riciclati al legno, dal tessuto alla pelle il tutto con un'attenzione speciale verso la circolarità del materiale e la sostenibilità dei processi produttivi. Tanti nuovi tessuti declinati in varianti colore sia per interni che per esterni che conferiscono alla campionatura un'ampia offerta e capacità di personalizzazione.*

*E proprio il dettaglio della campionatura trova al Salone una sua estetica rappresentazione di facile lettura e interpretazione.*



p. 04  
**H.H.H.**  
**HER HIGHEST HIGHNESS**  
des. P. Starck



p. 06  
**H.H.H.**  
**ECO-FRIENDLY TEXTURE**  
des. P. Starck



p. 07  
**H.H.H.**  
**LEATHER**  
des. P. Starck



p. 10  
**H.H.H. FABRIC**  
**LIBERTY.**  
des. P. Starck



p. 11  
**H.H.H. GRAPHIC IMPRESSION**  
**LIBERTY.**  
des. P. Starck



p. 28  
**Teresa**  
des. F. Laviani



p. 36  
**A.I. Lounge**  
des. P. Starck



p. 37  
**A.I. Lounge Outdoor**  
des. P. Starck



p. 52  
**A.I. Console**  
des. P. Starck



p. 62  
**Asia**  
des. P. Lissoni



p. 74  
**Four Extendable**  
des. F. Laviani



p. 75  
**Four XXL**  
des. F. Laviani



p. 82  
**Glossy XXL**  
des. A. Citterio



p. 88  
**Plastics Outdoor**  
**LIBERTY.**  
des. P. Lissoni



p. 96  
**Trix Outdoor**  
**LIBERTY.**  
des. P. Lissoni



p. 102  
**Cara Outdoor**  
**LIBERTY.**  
des. P. Starck



p. 108  
**K-Top**  
des. R. Dordoni



p. 110  
**Angelo Stone**  
des. P. Starck



p. 118  
**AAland**  
des. P. Urquiola



p. 119  
**Planet Ceiling**  
des. T. Yoshioka

NEW!



**5915**

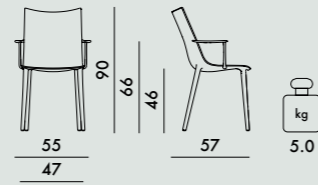

**MATERIAL**

Polycarbonate 2.0 from mass-dyed renewable raw material



New polycarbonate 2.0, a material that uses a renewable raw material from the pulp and paper industry in the synthesis phase. The process used for the production of the material is ISCC certified\* (International Sustainability and Carbon Certification)

	level reached
EN 1022 2005	Compliant
EN 16139:2013+AC 2013	Compliant
EN 1728:2012+AC 2013	
4.1	Compliant
4.2	Compliant
6.4	L2
6.5	L2
6.6	L2
6.10	L2
6.11	L2
6.15	L2
6.16	L2
6.17	L2
6.18	L2
6.20	L2
6.24	L2
6.25	L2
6.26	L2

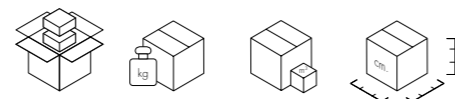

**5915** 1 7.0 0.332 60X59X94







5918

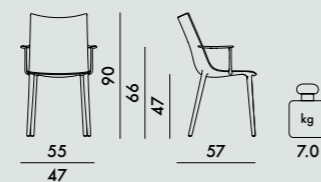

**FRAME**

Polycarbonate 2.0 from mass-dyed renewable raw material

**SEAT**

Soft recycled polyurethane coated in "Eco-Friendly Texture" fabric, composed of 15% recycled material and 55% material from renewable sources

**Eco-Friendly Texture**

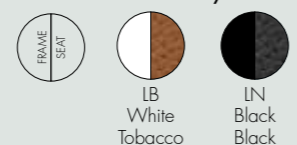

New polycarbonate 2.0, a material that uses a renewable raw material from the pulp and paper industry in the synthesis phase. The process used for the production of the material is ISCC certified\* (International Sustainability and Carbon Certification)



Made from recycled fabric

This technically innovative and eco-friendly textured covering is made partly from recycled materials and partly from renewable sources. It comes in the colours black and tobacco.

5918

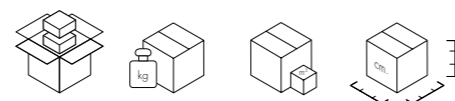

1 9.0 0.332 60X59X94

5917

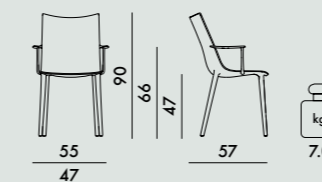

**FRAME**

Polycarbonate 2.0 from mass-dyed renewable raw material

**SEAT**

Soft recycled polyurethane coated in genuine leather tanned with natural treatments derived from waste from the olive oil industry

**Full-grain leather**



New polycarbonate 2.0, a material that uses a renewable raw material from the pulp and paper industry in the synthesis phase. The process used for the production of the material is ISCC certified\* (International Sustainability and Carbon Certification)

**AVOTAN®** New ecological, sustainable, and circular tanning process. Italy is one of the world's most important producers of leather goods and the second largest producer of olive oil in the world. Olive oil production generates a waste product: AVO or olive mill wastewater. This waste contains components that are very interesting for tanning: phenols and polyphenolic compounds with high antimicrobial and phytotoxic action, but also antioxidants and tannins. It combines two waste products from the agri-food industry to create a valuable, durable, eco-sustainable, and circular product. Unlike all other vegetable tans, it does not consume any natural resources, does not deforest but uses an existing waste that would otherwise need to be disposed of.

5917

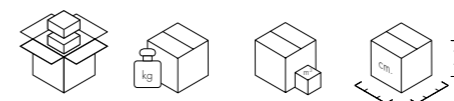

1 9.0 0.332 60X59X94



	level reached
EN 1022 2005	Compliant
EN 16139:2013+AC 2013	Compliant
EN 1728:2012+AC 2013	
4.1	Compliant
4.2	Compliant
6.4	L2
6.5	L2
6.6	L2
6.10	L2
6.11	L2
6.15	L2
6.16	L2
6.17	L2
6.18	L2
6.20	L2
6.24	L2
6.25	L2
6.26	L2

	level reached
EN 1022 2005	Compliant
EN 16139:2013+AC 2013	Compliant
EN 1728:2012+AC 2013	
4.1	Compliant
4.2	Compliant
6.4	L2
6.5	L2
6.6	L2
6.10	L2
6.11	L2
6.15	L2
6.16	L2
6.17	L2
6.18	L2
6.20	L2
6.24	L2
6.25	L2
6.26	L2





**Kartell**

×

**LIBERTY.**

H.H.H. armchair  
upholstered fabric  
des. P. Starck



5918

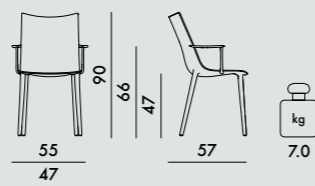

FRAME

Polycarbonate 2.0 from mass-dyed renewable raw material

SEAT

Soft recycled polyurethane coated in "Liberty" fabric

Flowers

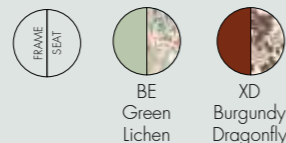

Patricia

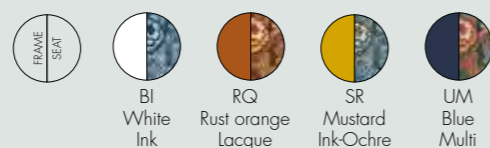

New polycarbonate 2.0, a material that uses a renewable raw material from the pulp and paper industry in the synthesis phase. The process used for the production of the material is ISCC certified\* (International Sustainability and Carbon Certification)

5919

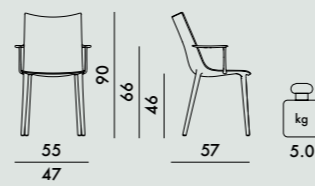

FRAME

Polycarbonate 2.0 from renewable raw material, mass-colored and printed with "Graphic Impression" technology

Moon Flower



Mabelle

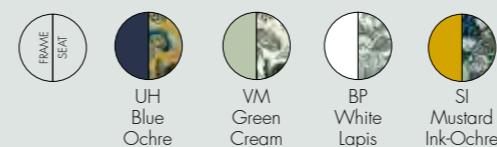

Harvest Time

Tumbling Wilde

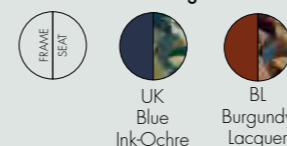

To create this exclusive finish, Kartell has developed a special new "graphic impression" technique that uses a high-tech printing process to produce graphic patterns directly on the chair body. This version comes in 4 floral and geometric patterns and in 11 colour variants. An original and ultramodern way to experience Liberty prints.



	level reached
EN 1022 2005	Compliant
EN 16139:2013+AC 2013	Compliant
EN 1728:2012+AC 2013	
4.1	Compliant
4.2	Compliant
6.4	L2
6.5	L2
6.6	L2
6.10	L2
6.11	L2
6.15	L2
6.16	L2
6.17	L2
6.18	L2
6.20	L2
6.24	L2
6.25	L2
6.26	L2

5918

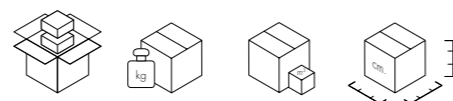

1 9.0 0.332 60X59X94

5919

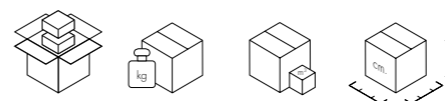

1 7.0 0.332 60X59X94

	level reached
EN 1022 2005	Compliant
EN 16139:2013+AC 2013	Compliant
EN 1728:2012+AC 2013	
4.1	Compliant
4.2	Compliant
6.4	L2
6.5	L2
6.6	L2
6.10	L2
6.11	L2
6.15	L2
6.16	L2
6.17	L2
6.18	L2
6.20	L2
6.24	L2
6.25	L2
6.26	L2





**Kartell**

×

**LIBERTY.**

H.H.H. armchair  
graphic impression  
des. P. Starck



**Kartell** × **LIBERTY.**  
**UPHOLSTERED FABRIC**

**FLOWERS**



BE  
Lichen



XD  
Dragonfly

**PATRICIA**



BI  
Ink



RQ  
Lacquer



SR  
Ink-Ochre



UM  
Multi

**Composition**  
63% CO; 37% LI  
**Martindale**  
≥25.000



FLAME  
PROOF

BS 5852-1:1979 CIGARETTE

ON REQUEST  
BS 5852-2:1979 MATCH  
EN1021-1:2006  
EN1021-2:2006



**Kartell** × **LIBERTY.**  
**GRAPHIC IMPRESSION**

**MOON FLOWER**



UO  
Ink-Ochre



BE  
Lichen



XQ  
Lacquer

**MABELLE**



VM  
Cream



UH  
Ochre

**HARVEST TIME**



BP  
Lapis



SI  
Ink-Ochre

**TUMBLING WILDE**



UK  
Ink-Ochre



BL  
Lacquer

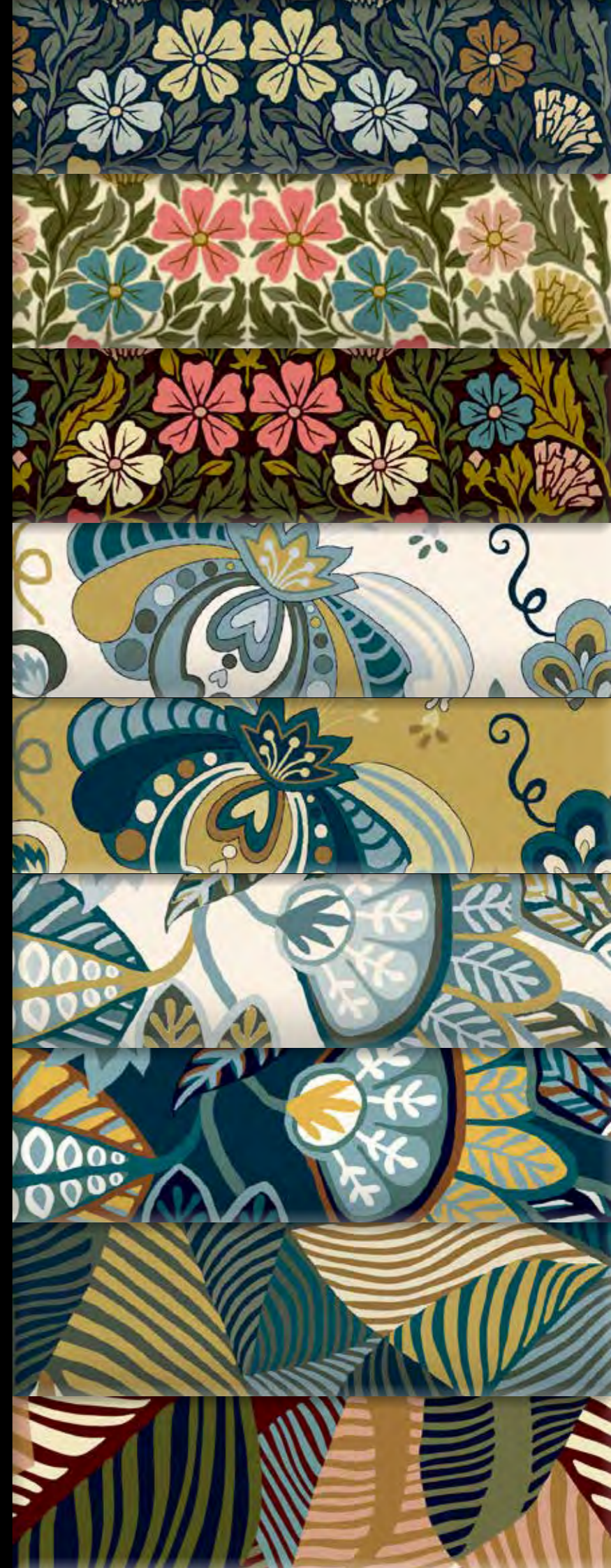



**LAYOUT 1GXL**  
H.H.H. Upholstered Fabric version

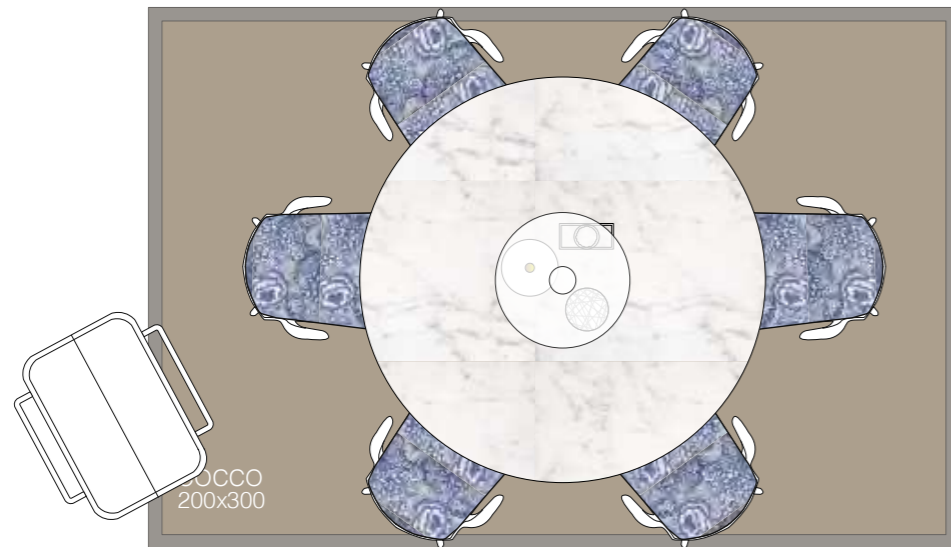
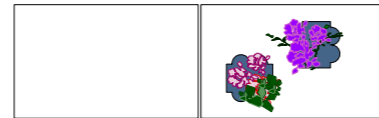
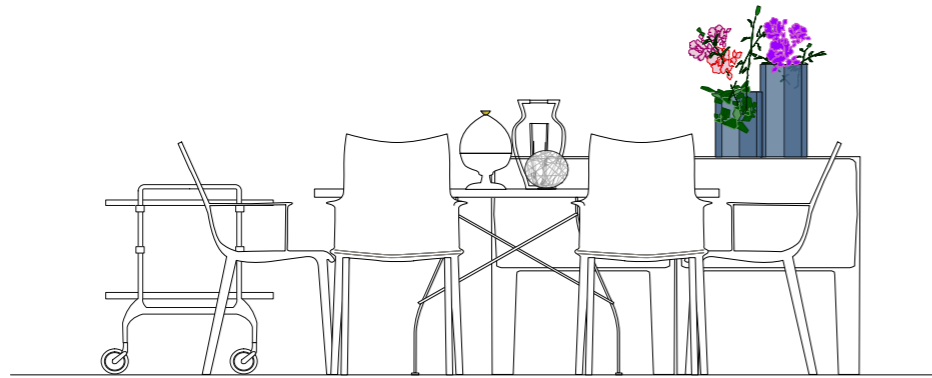
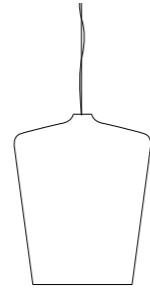

CODE	COLOR	DESCRIPTION	QTY LAYOUT	QTY PACK	TOTAL
09175	03	KABUKI SUSPENSION	1	0	1
04457	MB	GLOSSY XL	1	0	1
05918	BI	HHH UPHOLSTERED FABRIC	6	0	6
01584	04	OKRA	1	0	1
01585	04	OKRA	1	0	1
03210	E5	GHOST BUSTER	2	0	2
01215	B4	I SHINE	1	0	1
09410	B4	MINI PLANET BATTERY	1	0	1
01551	BT	PUMO	1	0	1
04473	03	GASTONE	1	0	1



# LAYOUT 3MUL

H.H.H. Graphic Impression version

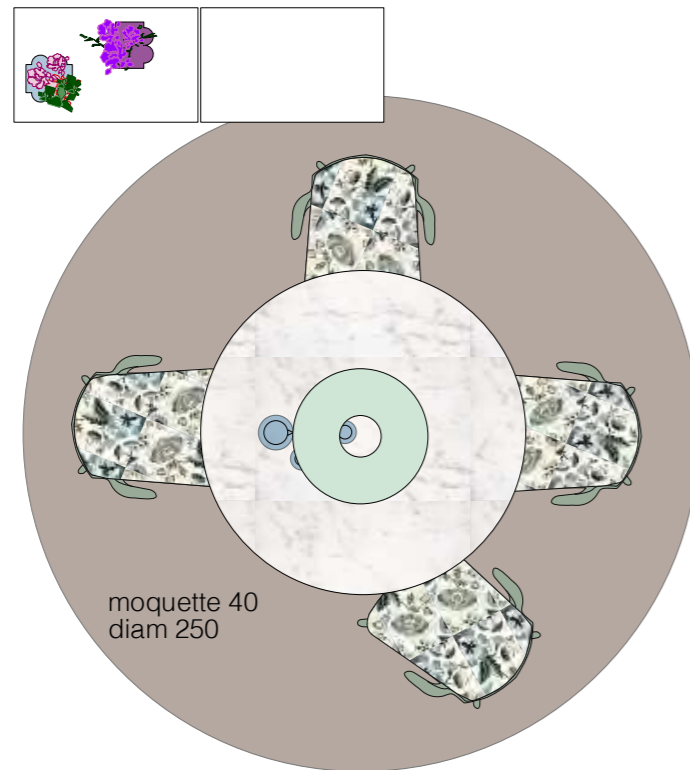

CODE	COLOR	DESCRIPTION	QTY LAYOUT	QTY PACK	TOTAL
05919	VM	HHH GRAPHIC IMPRESSION	4	0	4
04081	MB	MULTIPLO ROUND 118 CM	1	0	1
09455	VE	BELLISSIMA	1	0	1
03210	E5	GHOST BUSTER	2	0	2
01584	02	OKRA	1	0	1
01585	04	OKRA	1	0	1
01511	AZ	TRAMA CARAFFE	1	0	1
01513	AZ	TRAMA GLASS WATER	4	12	16





**LAYOUT 6VIS**  
H.H.H. Upholstered Fabric version

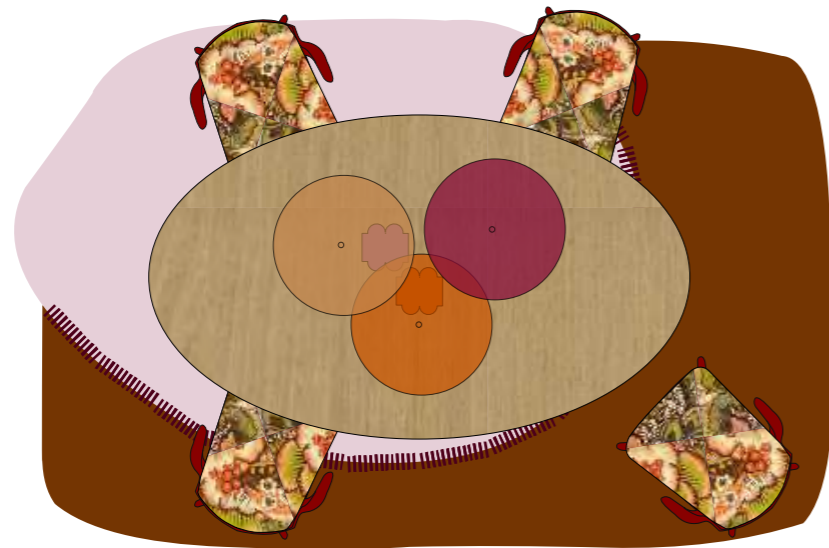

CODE	COLOR	DESCRIPTION	QTY LAYOUT	QTY PACK	TOTAL
04941	CF	VISCOUNT OF WOOD TABLE	1	0	1
05918	RQ	HHH UPHOLSTERED FABRIC	4	0	4
01584	02	OKRA	1	0	1
01585	01	OKRA	1	0	1
09030	BO	FL/Y SUSPENSION	1	0	1
09030	AM	FL/Y SUSPENSION	1	0	1
09030	CO	FL/Y SUSPENSION	1	0	1
02361	P8	CARPET	1	0	1



# LAYOUT 3TXL

H.H.H. Leather or Polycarbonate 2.0 version

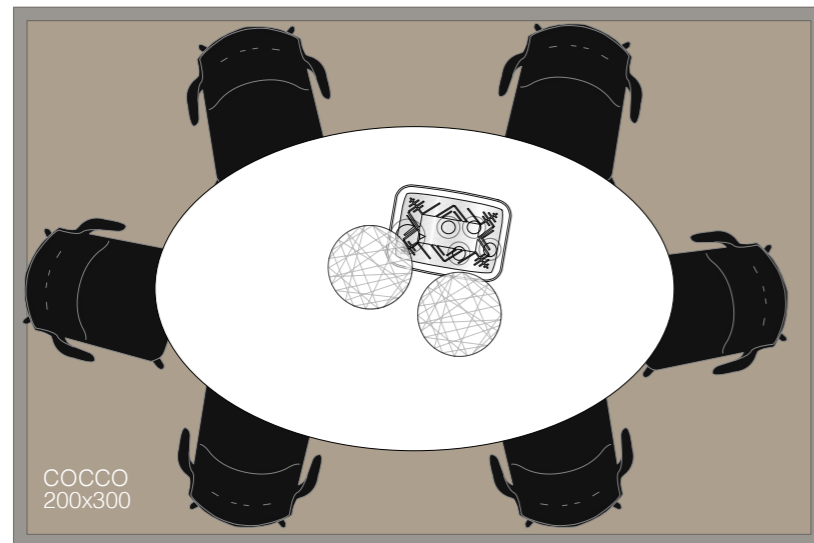
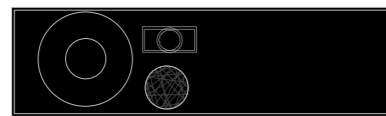
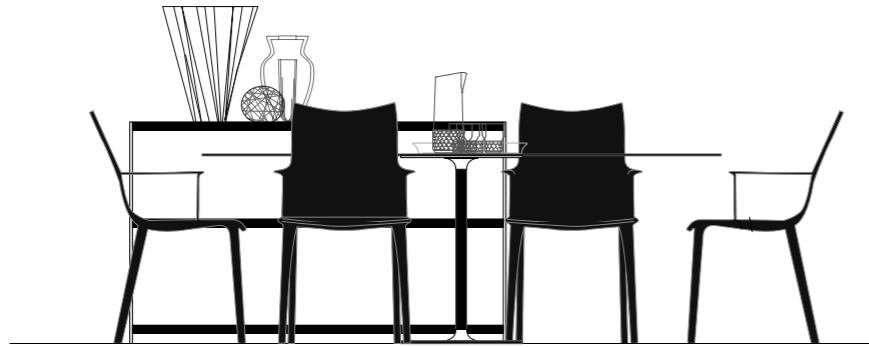
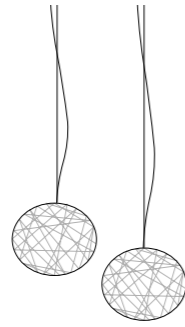

CODE	COLOR	DESCRIPTION	QTY LAYOUT	QTY PACK	TOTAL
09390	B4	PLANET SUSPENSION	2		2
04046	BI	THIERRY XXL	1		1
05917	NN	HHH LEATHER	6		6
09410	B4	MINI PLANET BATTERY	1		1
01229	B4	SHANGHAI	1		1
01215	B4	I SHINE	1		1
01490	B4	JELLY CARAFFE	1		1
01493	B4	JELLIES GLASS WINE	4	12	16
01965	XX	TEATIME	1		1
04418	O9	TRAYS	1		1
<b>ALTERNATIVE CHAIR</b>					
05915	PN	HHH	6		6



# LAYOUT 4TXL

H.H.H. Polycarbonate 2.0 version

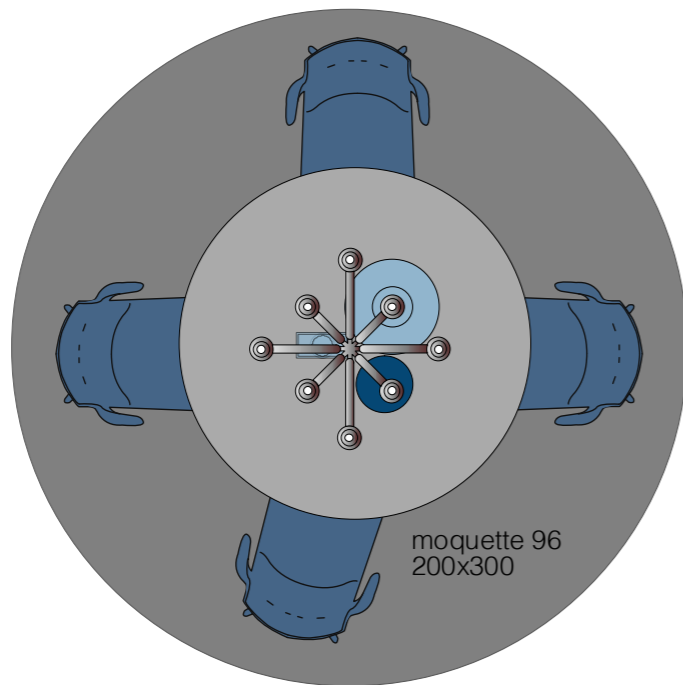
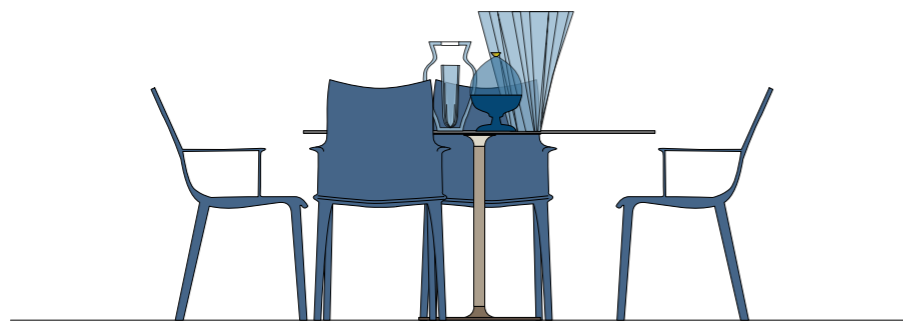
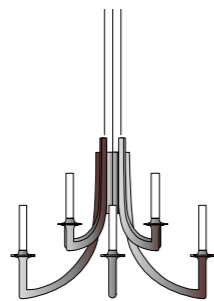

CODE	COLOR	DESCRIPTION	QTY LAYOUT	QTY PACK	TOTAL
G9555	GG	KHAN	1		1
04045	GR	THIERRY XXL ROUND	1		1
05915	PU	HHH	4		4
01215	E4	I SHINE	1		1
01551	BA	PUMO	1		1
01229	BL	SHANGHAI	1		1





# LAYOUT 1FOC

CODE	COLOR	DESCRIPTION	QTY LAYOUT	QTY PACK	TOTAL
05915	PS	HHH	1		1
05915	PU	HHH	1		1
05917	BC	HHH LEATHER	1		1
05918	BI	HHH UPHOLSTERED FABRIC	1		1
05919	UO	HHH GRAPHIC IMPRESSION	1		1

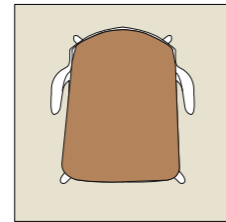
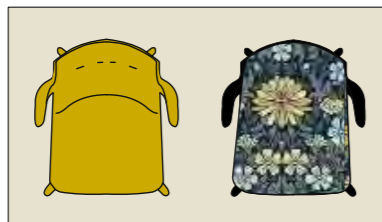
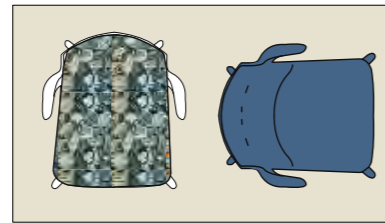

# TERESA SPECIAL EDITION SALONE 2024

Design Ferruccio Laviani

# TERESA 2024

Design Ferruccio Laviani



9105

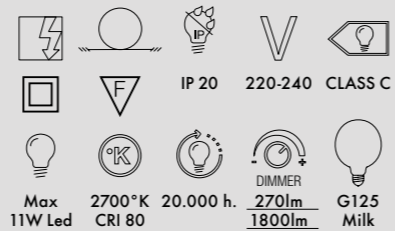
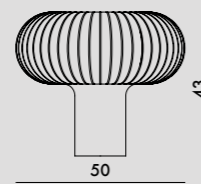

### MATERIAL

Batch-dyed recycled PMMA

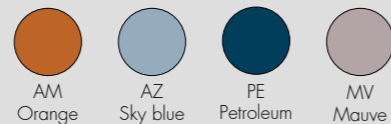

Product made of recycled material

JJ20

One E27 11W LED G125 MILK light bulb included  
Cannot be sold separately

9105

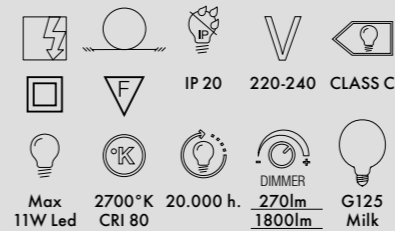
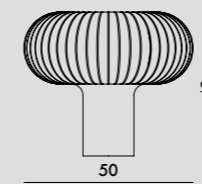

### MATERIAL

Batch-dyed recycled PMMA

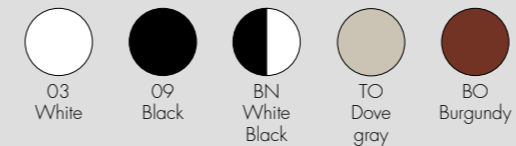

Product made of recycled material

JJ20

One E27 11W LED G125 MILK light bulb included  
Cannot be sold separately

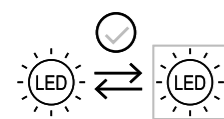

The light source can be replaced with a similar source, respecting the data indicated on the label. We recommend using a light source with a colour temperature of 2700 K.

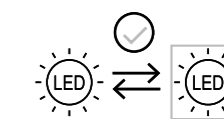

The light source can be replaced with a similar source, respecting the data indicated on the label. We recommend using a light source with a colour temperature of 2700 K.

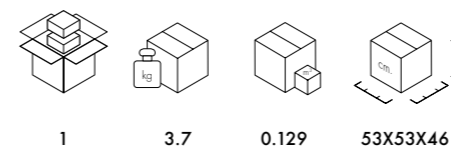
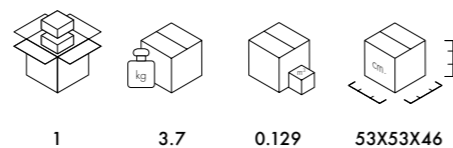

# LAYOUT ITER

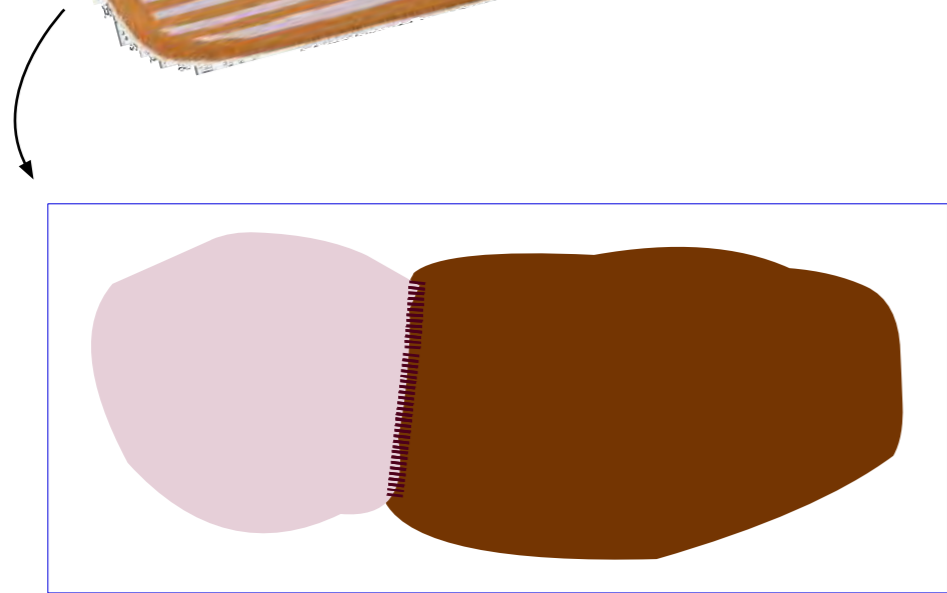
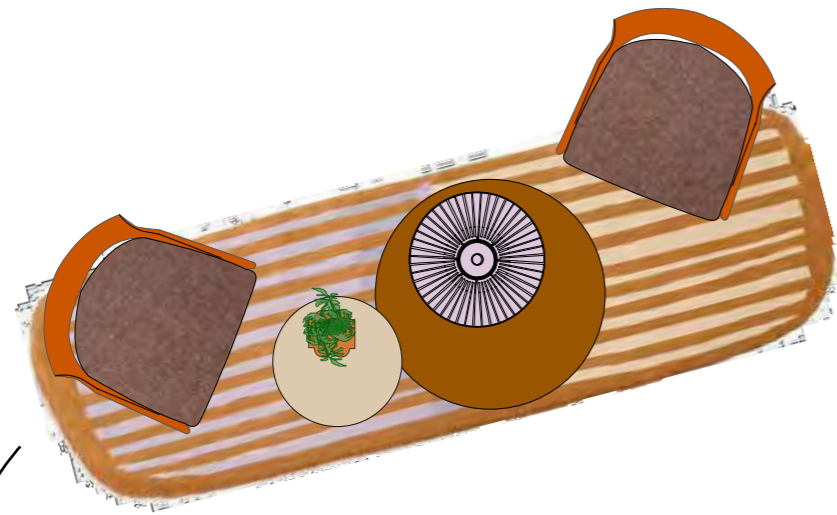
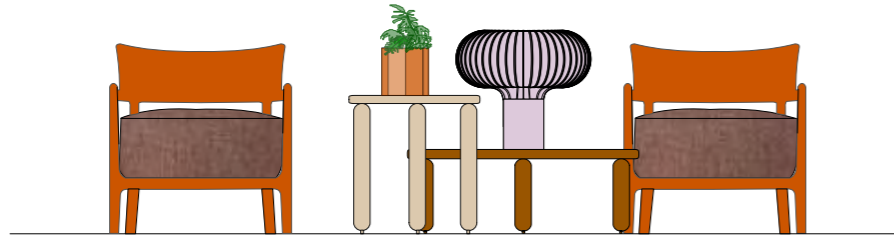

CODE	COLOR	DESCRIPTION	QTY LAYOUT	QTY PACK	TOTAL
09105	MV	TERESA	1		1
05842	3C	CARA	2		2
04170	AR	UNDIQUE MAS	1		1
04168	RO	UNDIQUE MAS	1		1
02359	P2	CARPET	1		1
<b>ALTERNATIVE CARPET</b>					
02362	P8	CARPET	1		1





# LAYOUT 2TER A/B

A

B

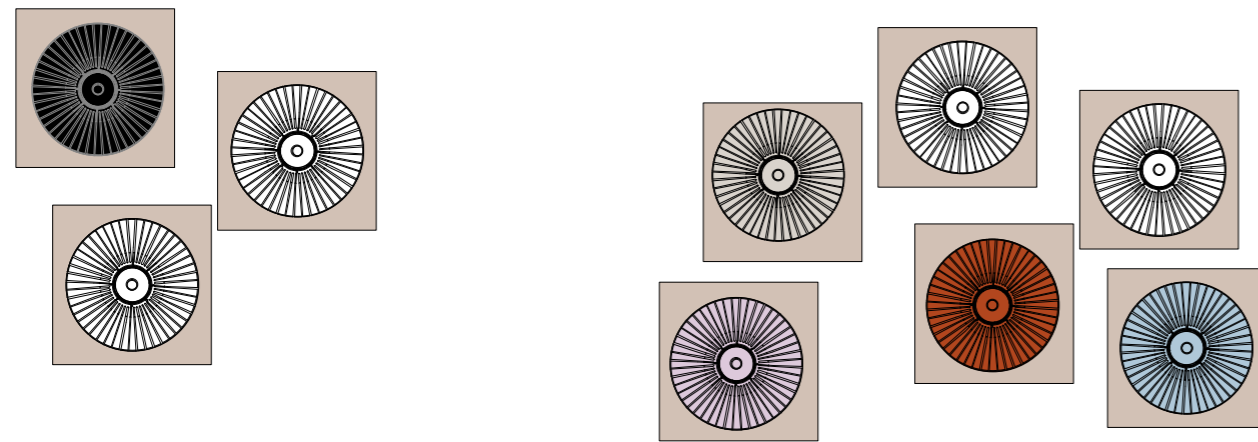

## 2TER A

CODE	COLOR	DESCRIPTION	QTY LAYOUT	QTY PACK	TOTAL
09105	09	TERESA	1		1
09105	03	TERESA	1		1
09105	BN	TERESA	1		1

## 2TER B

CODE	COLOR	DESCRIPTION	QTY LAYOUT	QTY PACK	TOTAL
09105	MV	TERESA	1		1
09105	AM	TERESA	1		1
09105	TO	TERESA	1		1
09105	AZ	TERESA	1		1
09105	BN	TERESA	1		1
09105	03	TERESA	1		1



# LAYOUT 3TER A/B

A

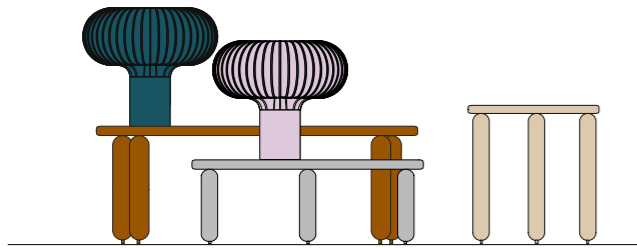

B

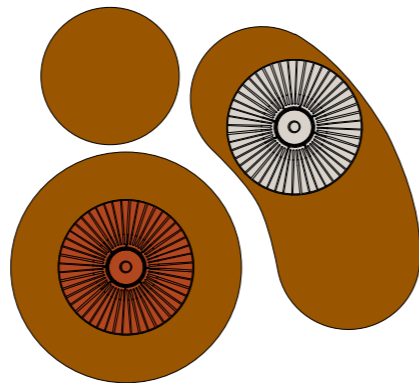
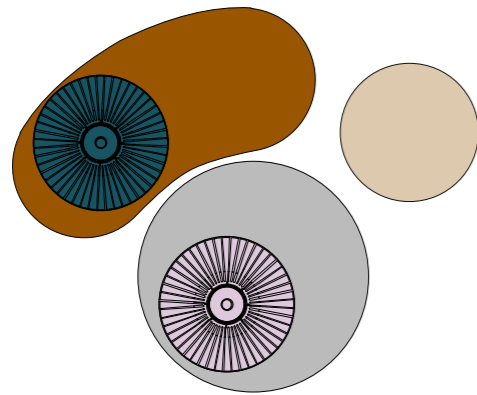
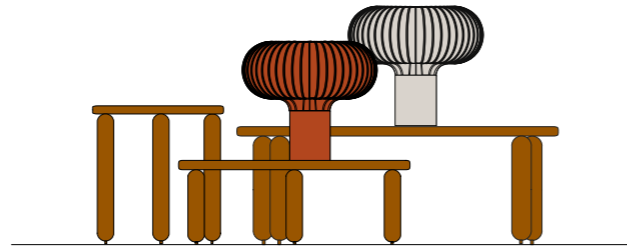

3TER A					
CODE	COLOR	DESCRIPTION	QTY LAYOUT	QTY PACK	TOTAL
09105	MV	TERESA	1		1
09105	PE	TERESA	1		1
04168	RO	UNDIQUE MAS	1		1
04170	GR	UNDIQUE MAS	1		1
04173	AR	UNDIQUE MAS	1		1

3TER B					
CODE	COLOR	DESCRIPTION	QTY LAYOUT	QTY PACK	TOTAL
09105	AM	TERESA	1		1
09105	TO	TERESA	1		1
04168	AR	UNDIQUE MAS	1		1
04170	AR	UNDIQUE MAS	1		1
04173	AR	UNDIQUE MAS	1		1





# A.I. LOUNGE 2023

Design Philippe Starck



5904

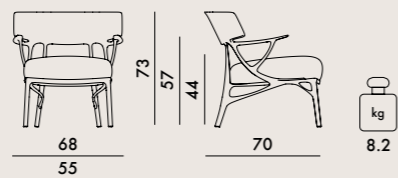

### FRAME

recycled thermoplastic technopolymer with mineral filler and soft-touch treatment

### SEAT

Indeformable expanded recycled polyurethane cushions with differentiated density and polyester fiber, covered in removable fabric

#### Bouclé Riccio



#### Panamino Basic



#### Texture



Product made of recycled material



Removable cover

**A5904** Fire tested version for following fabrics:  
BOUCLÉ RICCIO FABRIC  
BS5852-2:1979 UK DOMESTIC

5904

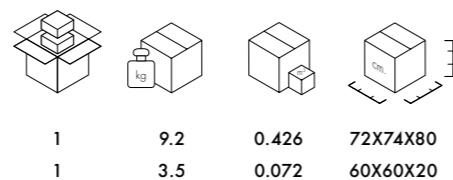

5904

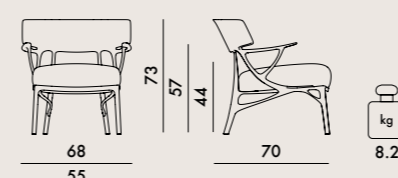

### FRAME

recycled thermoplastic technopolymer with mineral filler and soft-touch treatment

### SEAT

Indeformable expanded recycled polyurethane with differentiated density, covered with water-repellent (welded) fabric, coated in water-repellent or draining fabric, removable

#### Twill



Product made of recycled material



Removable cover

5904

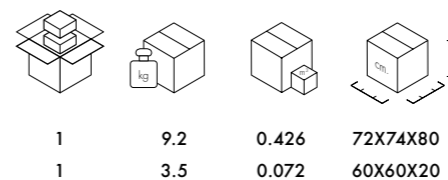

# A.I. LOUNGE OUTDOOR 2024

Design Philippe Starck

# LAYOUT 1A1L

A.I. Lounge Indoor Texture fabric version

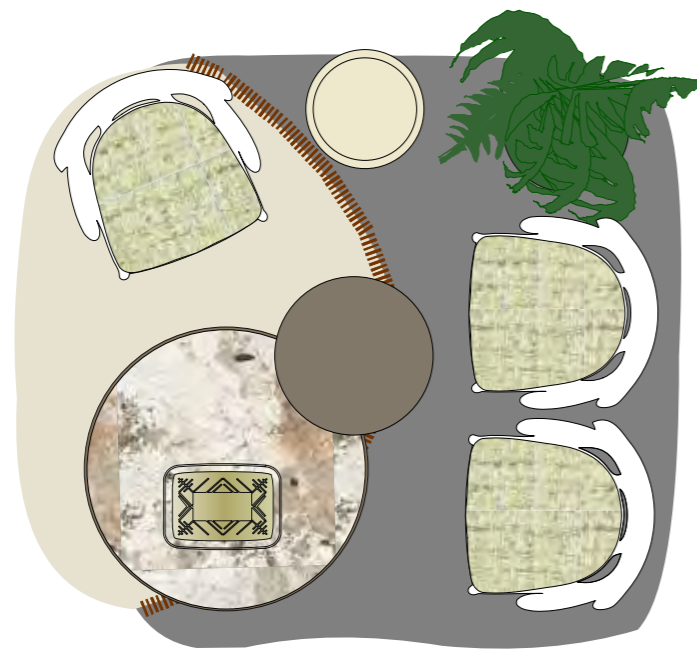

CODE	COLOR	DESCRIPTION	QTY LAYOUT	QTY PACK	TOTAL
05904	1Y	A.I. LOUNGE	3		3
09400	BL	ANGELO STONE	1		1
04297	MS	K-TOP	1		1
04294	TU	K-TOP	1		1
01965	GG	TEATIME	1		1
02363	P6	CARPET	1		1
02374	GS	KLEO COVER	1		1





# LAYOUT 2AIL

A.I. Lounge Indoor Bouclé Riccio fabric version

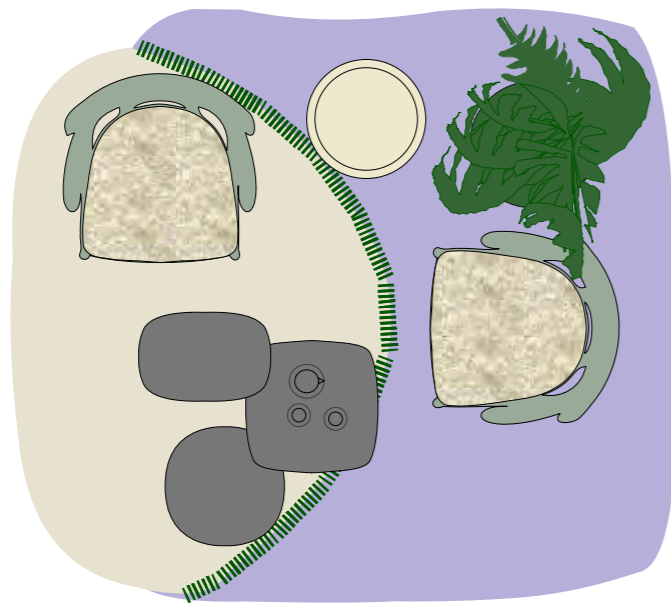

CODE	COLOR	DESCRIPTION	QTY LAYOUT	QTY PACK	TOTAL
05904	2B	A.I. LOUNGE	2		2
09400	BL	ANGELO STONE	1		1
04043	GR	THIERRY SET 3 PCS	1		1
01511	FU	TRAMMA CARAFE	1		1
01514	FU	TRAMA GLASS WINE	2	14	16
02363	P7	CARPET	1		1
02374	GS	KLEO COVER	1		1



# LAYOUT 3AIL

A.I. Lounge Indoor Bouclé Riccio fabric version

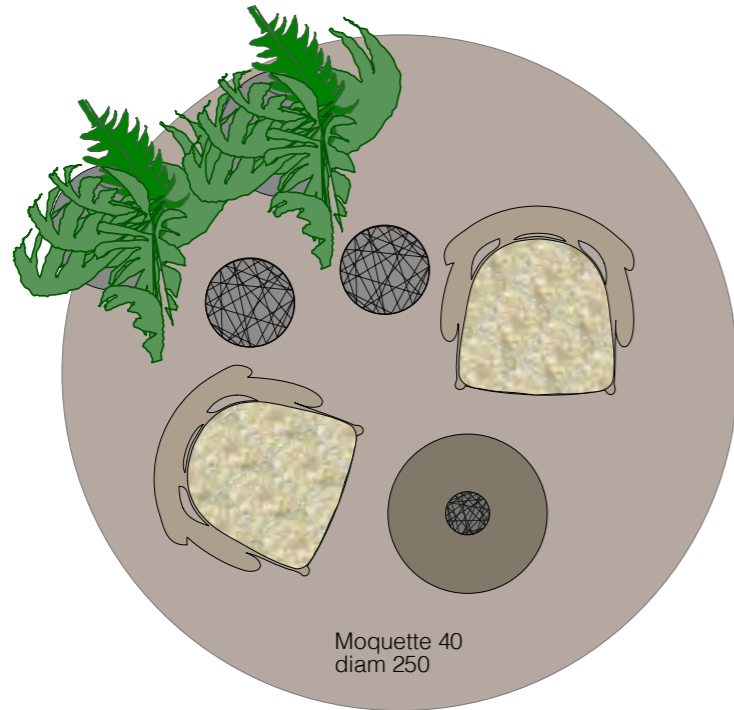

CODE	COLOR	DESCRIPTION	QTY LAYOUT	QTY PACK	TOTAL
05904	3B	A.I. LOUNGE	2		2
09387	FU	PLANET FLOOR	1		1
09388	FU	PLANET FLOOR	1		1
04294	TU	K-TOP	1		1
09410	FU	MINI PLANET	1		1
02374	GS	KLEO COVER	2		2





# LAYOUT 7AIL

A.I. Lounge Indoor Texture fabric version

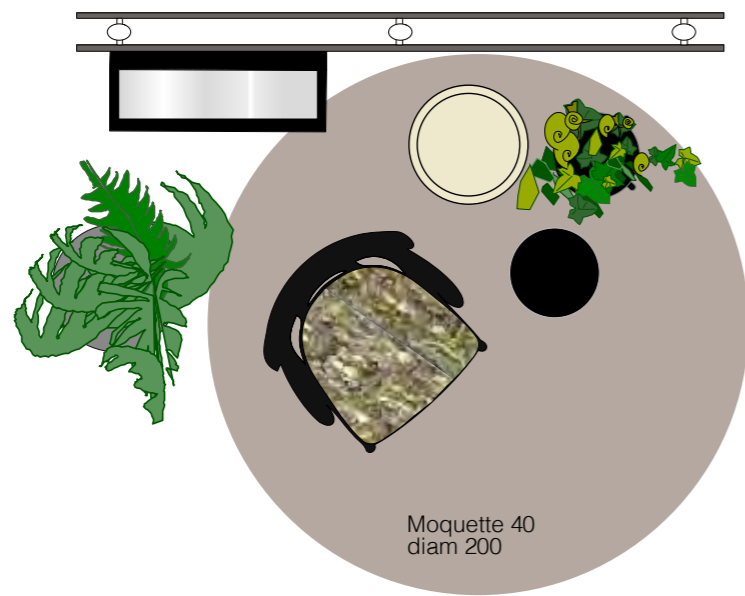

CODE	COLOR	DESCRIPTION	QTY LAYOUT	QTY PACK	TOTAL
05904	4V	A.I. LOUNGE	1		1
09400	TT	ANGELO STONE	1		1
01227	B4	JELLY VASE	1		1
05902	NE	A.I. STOOL LIGHT	1	1	2
08831	09	ATTILA	1		1
08330	E6	ONLY ME	1		1
02374	GS	KLEO COVER	1		1



# LAYOUT 3FOC

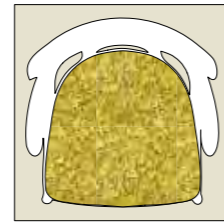
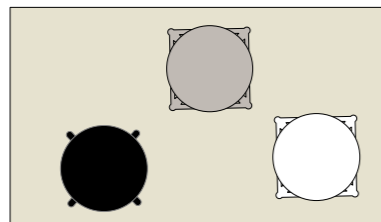
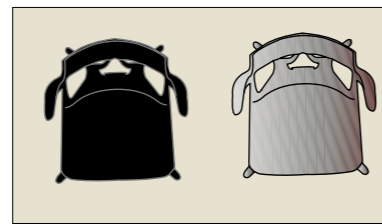
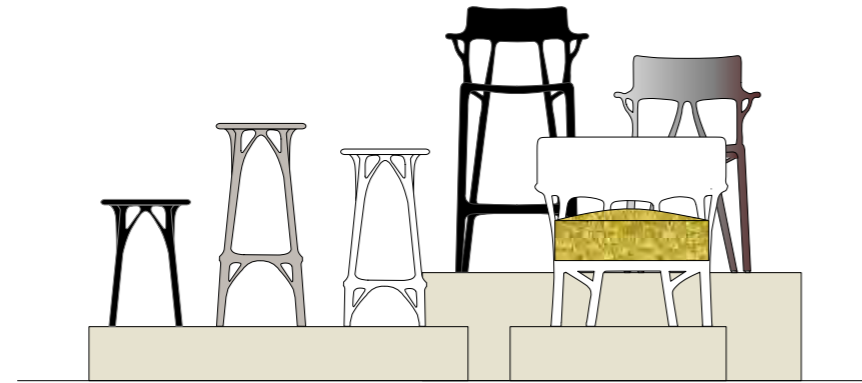

CODE	COLOR	DESCRIPTION	QTY LAYOUT	QTY PACK	TOTAL
05887	OY	A.I.	1		1
05889	NE	A.I. STOOL	1		1
05904	1L	A.I. LOUNGE	1		1
05901	NE	A.I. STOOL LIGHT	1	1	2
05902	BI	A.I. STOOL LIGHT	1	1	2
05903	GR	A.I. STOOL LIGHT	1	1	2





# LAYOUT 5AIL

A.I. Lounge Outdoor version

# outdoor

CODE	COLOR	DESCRIPTION	QTY LAYOUT	QTY PACK	TOTAL
05904	OW	A.I. LOUNGE OUTDOOR	2		2
09910	B4	SOUND RACK	2		2
09410	B4	MINI PLANET	3		3
09410	FU	MINI PLANET	1		1
04988	O3	COMPONIBILE 3	1		1
04986	O3	COMPONIBILE 2	1		1
02356	F9	KLIM	1		1

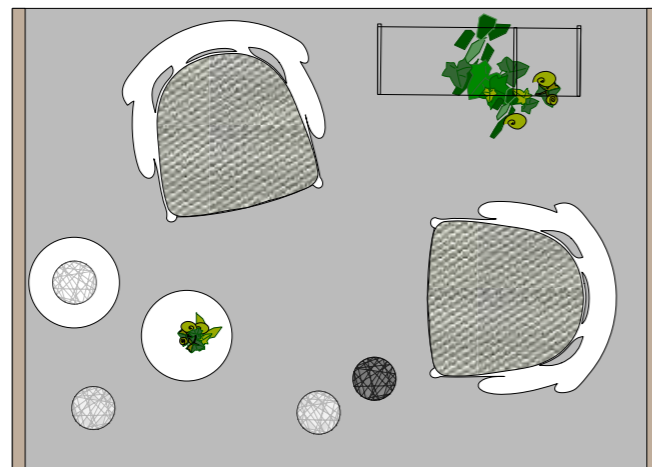

**LAYOUT 6AIL**  
A.I. Lounge Outdoor version

**outdoor**

CODE	COLOR	DESCRIPTION	QTY LAYOUT	QTY PACK	TOTAL
05904	OB	A.I. LOUNGE OUTDOOR	2		2
09185	03	KABUKI	1		1
01229	E5	SHANGHAI	1		1
05902	BI	A.I. STOOL LIGHT	1	1	2
04043	BL	THIERRY SET 3 PCS	1		1
01582	B4	JELLIES COFFE SET	1	3	4
01583	B4	JELLIES SUGAR BOWL	1		1
02356	F8	KLIM	1		1

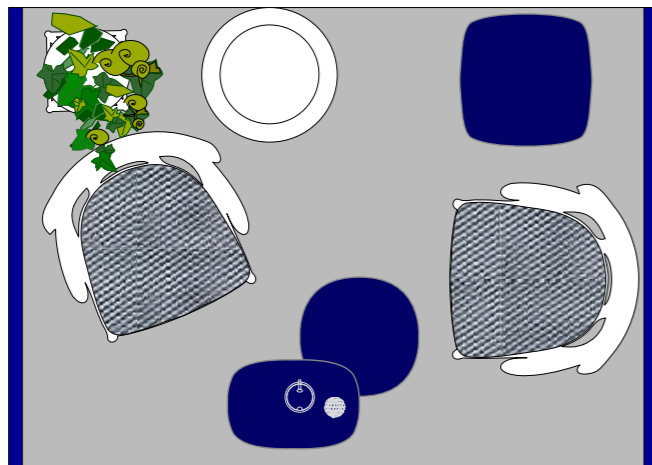

NEW!

# A.I. CONSOLE 2023

Design Philippe Starck powered by 

 **NEW SUSTAINABLE MATERIAL**



5907

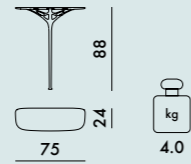

NEW

### MATERIAL

post-industrial recycled thermoplastic technopolymer obtained from Illy coffee pods

MAT



BI  
White



NE  
Black



GR  
Gray



AR  
Rusty  
orange



Made with the recovery of waste plastic materials from illycaffè iperespresso capsules

A new major partnership with the Illy Group supplements the unwavering research conducted by Kartell to develop innovative materials and promote sustainable production. For the first time ever, post industrial waste coffee pods are being used to regenerate material, which is ground into a granule-like consistency to give rise to the second raw material, giving the material a new lease on life so it can be injected into a Kartell mould to produce a designer product. The partnership with Illy does not stop with the mere supply of recycled material, but it embraces a new way of managing the circular economy process between two excellences. The quality of a consumer industrial product leads to an industrial project which generates beauty and is in itself based on quality. It took almost two years of work to achieve the quality standard and the necessary mechanics to produce a chair from waste coffee pods.



powered by illy

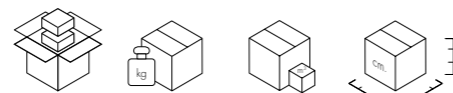

5907

1

6.6

0.215

100X77X28





# LAYOUT 1CON

CODE	COLOR	DESCRIPTION	QTY LAYOUT	QTY PACK	TOTAL
08300	B4	FRANCOIS GHOST	1		1
05907	GR	A.I. CONSOLE	1		1
01511	B4	TRAMA CARAFE	1		2
09570	TO	GOODNIGHT APPLIQUE	2		2



# LAYOUT 2CON

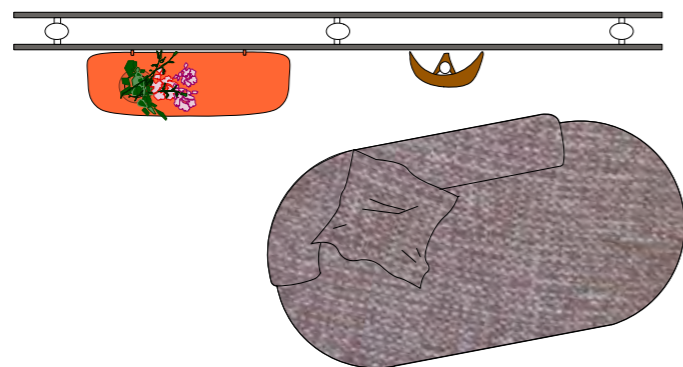
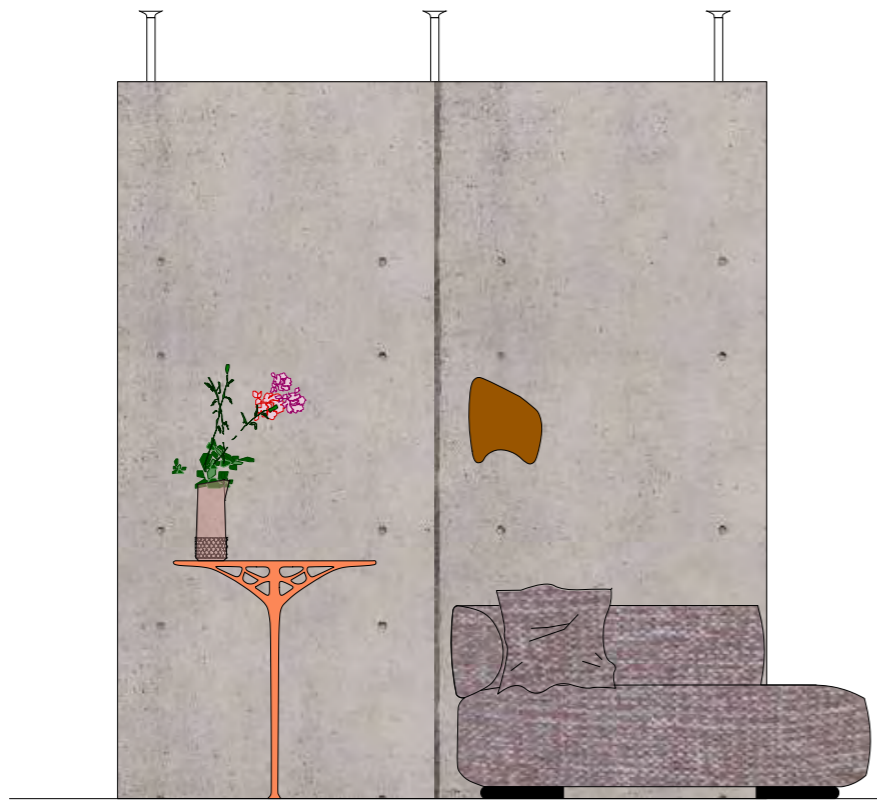

CODE	COLOR	DESCRIPTION	QTY LAYOUT	QTY PACK	TOTAL
09008	TE	TEA APPLIQUE	1		1
05907	AR	A.I. CONSOLE	1		1
06284	TB	K-WAITING DORMEUSE	1		1
07180	TB	K-WAITING CUSHION	1		1
01490	B4	JELLIES CARAFE	1		1



# LAYOUT 3CON

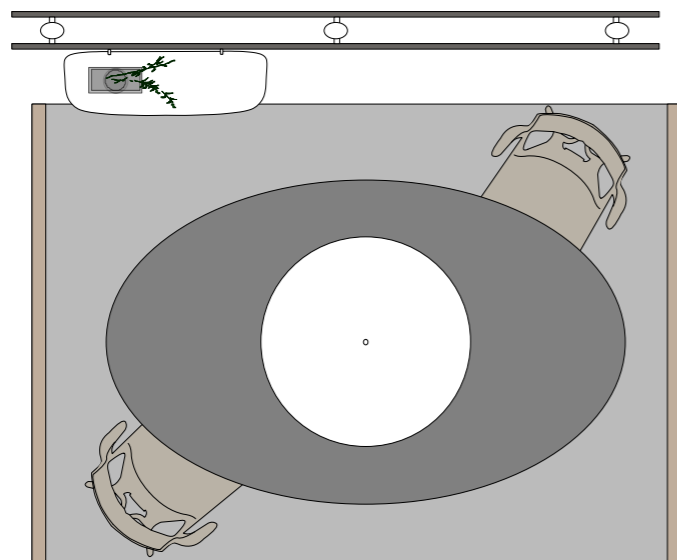

CODE	COLOR	DESCRIPTION	QTY LAYOUT	QTY PACK	TOTAL
09097	BB	BIG FL/Y	1		1
05907	BI	A.I. CONSOLE	1		1
04046	GR	THIERRY XXL	1		1
05886	GR	A.I.	2		2
02356	F9	KLIM	1		1
01215	V9	I-SHINE	1		1





# LAYOUT 4CON

CODE	COLOR	DESCRIPTION	QTY LAYOUT	QTY PACK	TOTAL
08306	BB	FRANCOIS GHOST	1		1
01215	B4	I SHINE	1		1
05907	BI	A.I. CONSOLE	1		1
05904	1L	A.I. LOUNGE	1		1
09180	03	KABUKI INDOOR	1		1

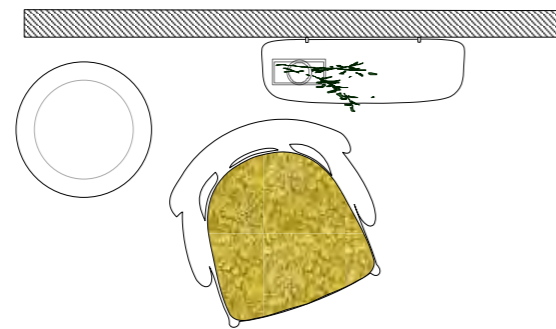



### 7275

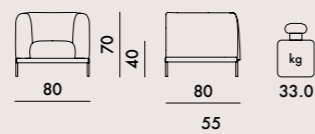

### 7276



### 7277

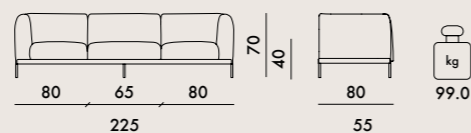

#### FRAME

Painted steel

#### SEAT AND BACKREST

Polyurethane with fabric upholstery

### 7180

Cushion



#### MATERIAL

Fabric-upholstered goose feather and down cushions



Removable cover

#### Cotone Plain



#### Panamino

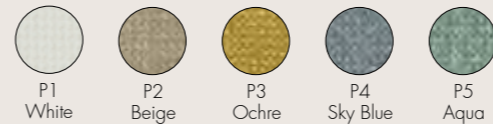

#### Bouclé New



#### Cotone Structure

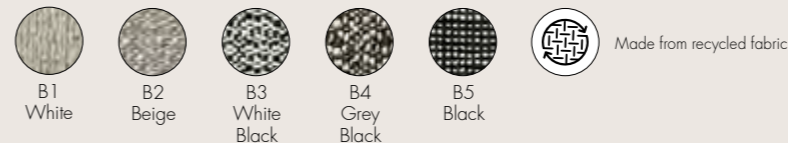

**A7275/A7276/A7277** Fire tested version for following fabrics:  
 PANAMINO FABRIC  
 BS5852-S2 Domestic UK - 11M CLASS  
 BOUCLÉ NEW FABRIC  
 BS5852-S2 Domestic UK - CALIFORNIA TB 117:2013



EN 1022:2005	Compliant
EN 1728:2012+AC2013	level reached
6.6	(maximum level) L2
6.10	(maximum level) L2
6.11	(maximum level) L2
6.15	(maximum level) L2
6.16	(maximum level) L2
6.17	(maximum level) L2
6.18	(maximum level) L2
6.20	(maximum level) L2
6.25	(maximum level) L2
6.26	(maximum level) L2

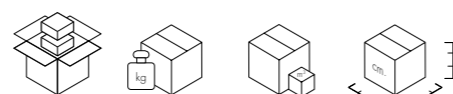

<b>7275</b>	1	40.0	0.541	85X85X75
<b>7276</b>	1	80.0	1.051	165X85X75
<b>7277</b>	1	120.0	1.466	230X85X75
<b>7180</b>	1	1.85	0.039	51X51X15



**NEW!**

# ASIA FABRICS

Design Piero Lissoni

## COTONE PLAIN



C1  
**WHITE**



C2  
**BEIGE**



C3  
**GREY**

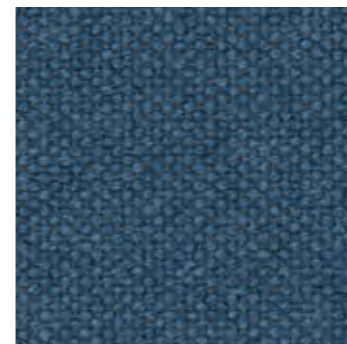

C4  
**BLUE**



## COTONE STRUCTURE



B1  
**WHITE**



B2  
**BEIGE**

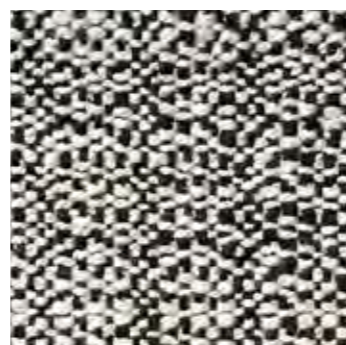

B3  
**WHITE/BLACK**



B4  
**GREY/BLACK**

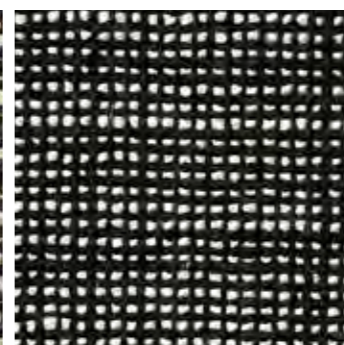

B5  
**BLACK**



## PANAMINO



P1  
**WHITE**



P2  
**BEIGE**



P3  
**OCHRE**

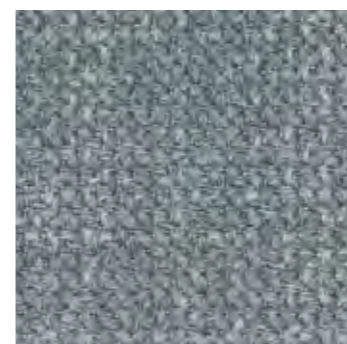

P4  
**SKY BLUE**

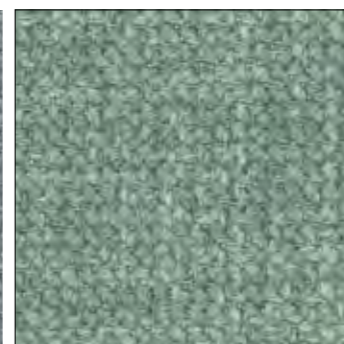

P5  
**AQUA**



## BOUCLÉ NEW



N1  
**WHITE**



N2  
**BEIGE**



N3  
**GREY**



N4  
**MUSTARD**



N5  
**BURGUNDY**

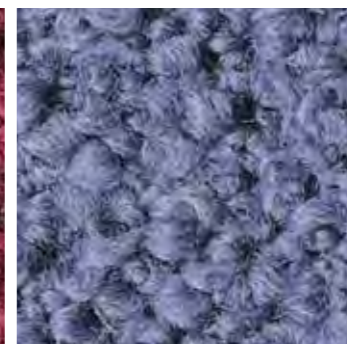

N6  
**POWDER BLUE**



# LAYOUT 1ASI

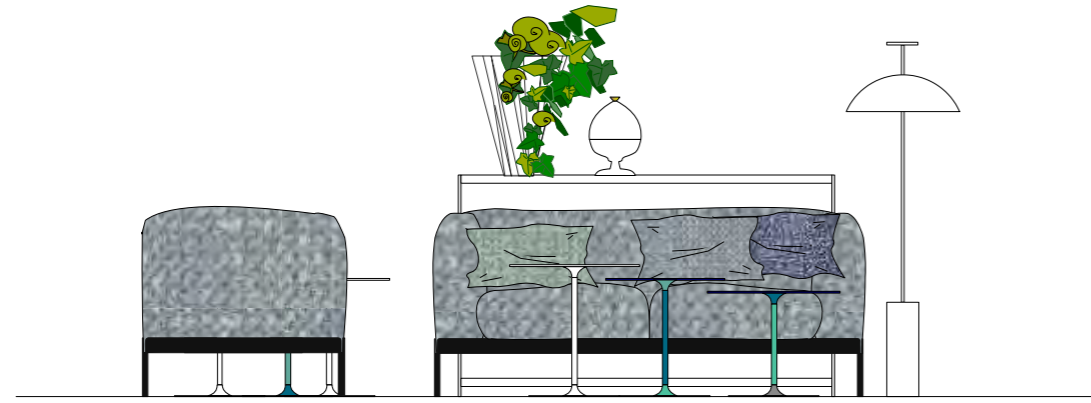

CODE	COLOR	DESCRIPTION	QTY LAYOUT	QTY PACK	TOTAL
07275	P4	ASIA ARMCHAIR	1		1
07276	P4	AISA SOFA 2 SEATS	1		1
07180	P4	CUSHION	1		1
07180	P5	CUSHION	2		2
07180	N6	CUSHION	2		2
04043	BL	THIERRY SET 3 PCS	1		1
04043	BI	THIERRY SET 3 PCS	1		1
01551	BT	PUMO	1		1
01229	B4	SHANGHAI	1		1
04418	03	TRAYS	1		1
09700	03	GEEN-A	1		1
02357	F8	KLIM	1		1

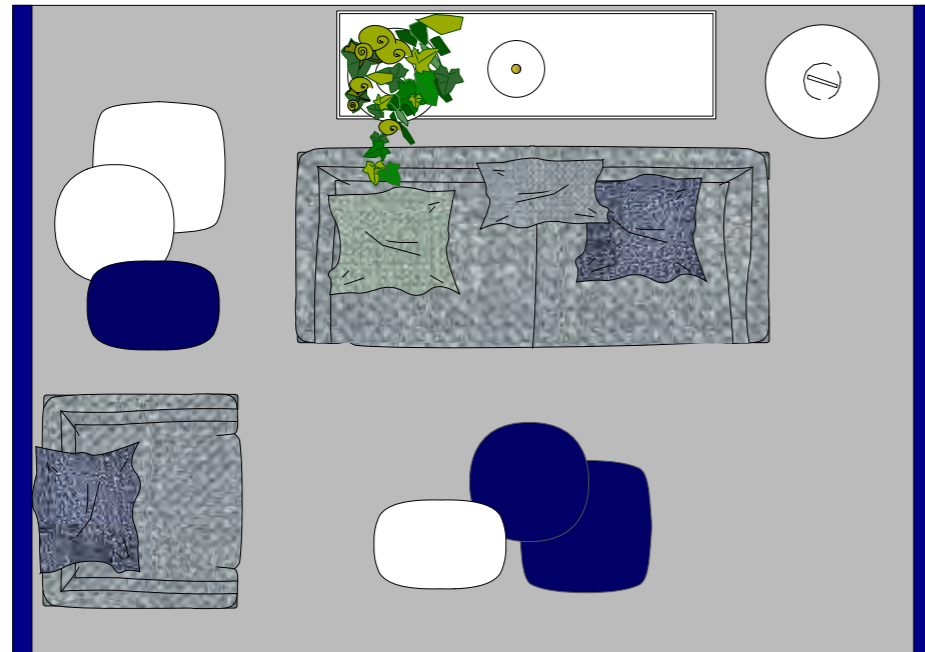

# LAYOUT 2ASI

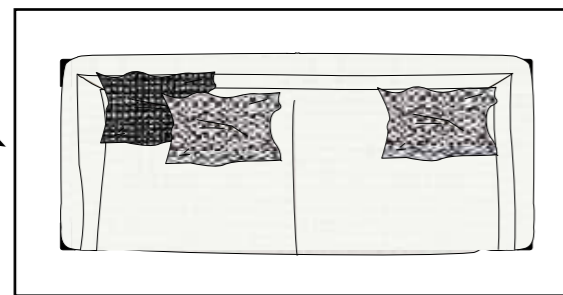
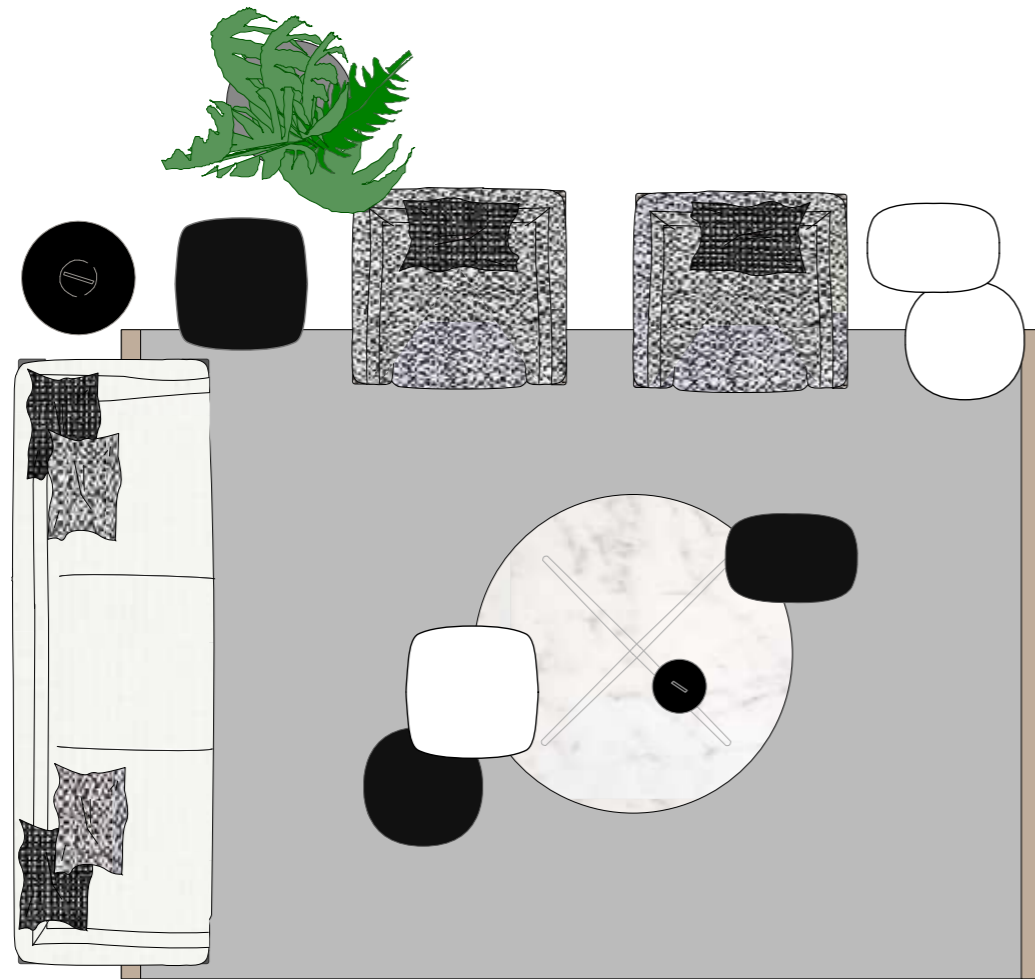

CODE	COLOR	DESCRIPTION	QTY LAYOUT	QTY PACK	TOTAL
07275	B3	ASIA ARMCHAIR	2		2
07277	B1	AISA SOFA 3 SEATS	1		1
07180	B3	CUSHION	2		2
07180	B5	CUSHION	4		4
04043	NE	THIERRY SET 3 PCS	1		1
04043	BI	THIERRY SET 3 PCS	1		1
02374	GS	KLEO COVER	1		1
04152	MB	MULTIPLIO LOW	1		1
09710	09	MINI GEEN-A	1		1
09700	09	GEEN-A	1		1
02357	F9	KLIM	1		1
<b>ALTERNATIVE SOFA</b>					
07276	B1	AISA SOFA 2 SEATS	1		1





# LAYOUT 3ASI

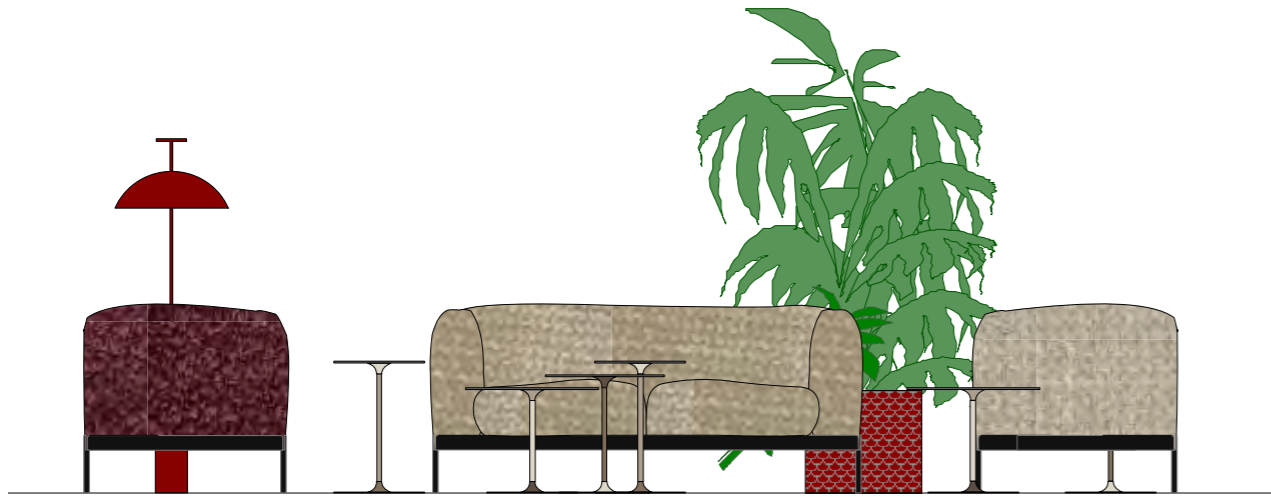

CODE	COLOR	DESCRIPTION	QTY LAYOUT	QTY PACK	TOTAL
07275	N5	ASIA ARMCHAIR	2		2
07276	P2	AISA SOFA 2 SEATS	2		2
07180	P2	CUSHION	2		2
07180	P3	CUSHION	2		2
07180	N4	CUSHION	2		2
04043	GR	THIERRY SET 3 PCS	2		2
02374	R1	KLEO COVER	1		1
09700	MA	GEEN-A	1		1
02357	F9	KLIM	1		1

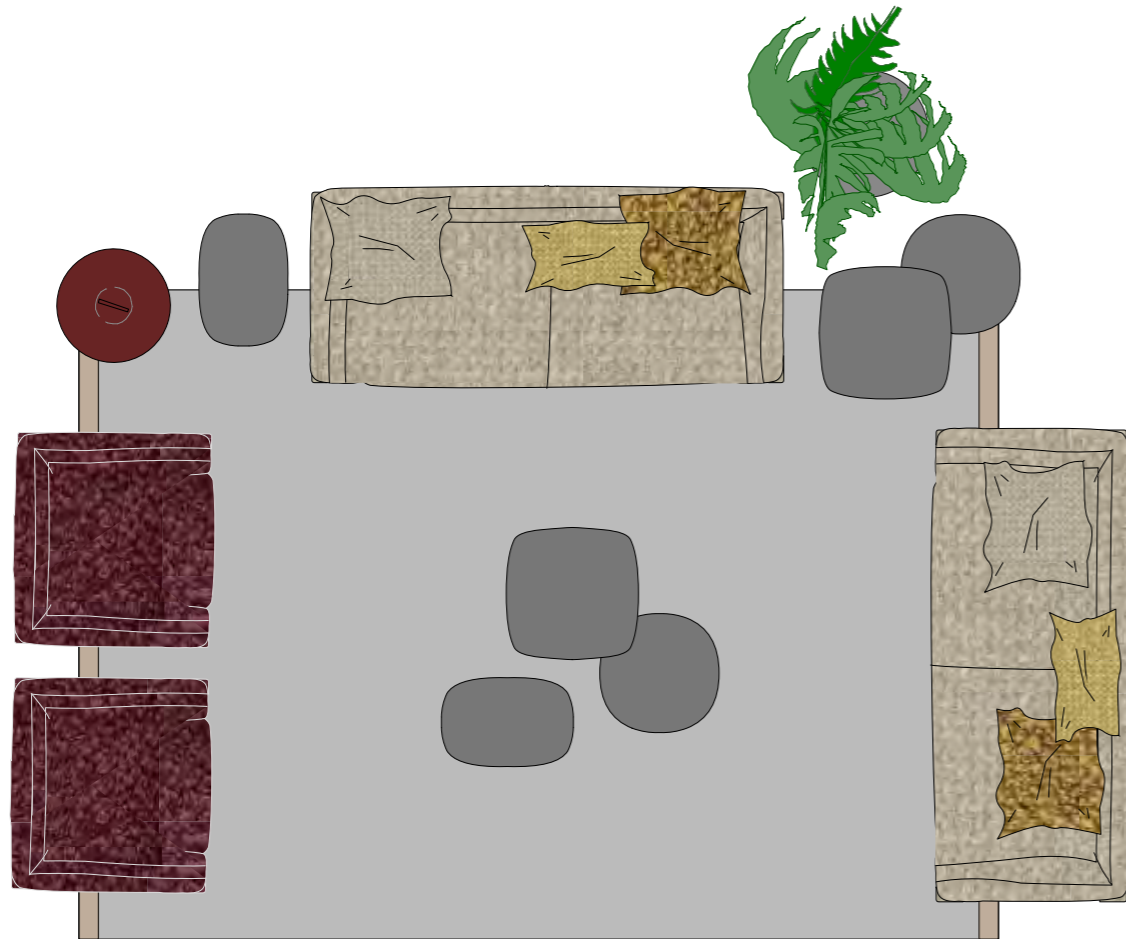



# LAYOUT 4ASI

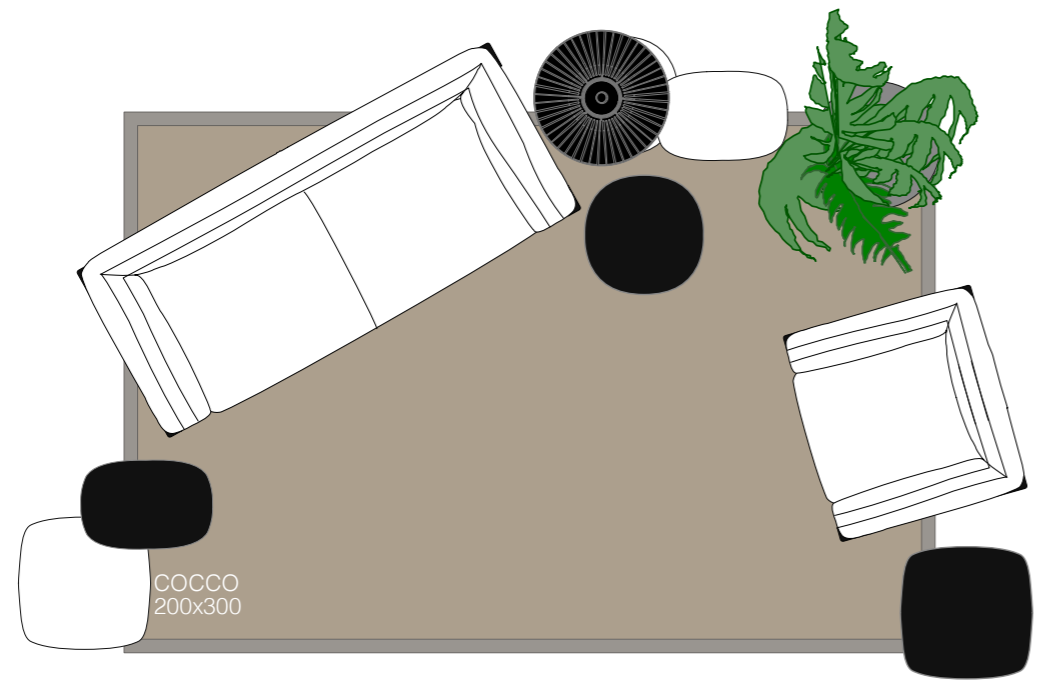

CODE	COLOR	DESCRIPTION	QTY LAYOUT	QTY PACK	TOTAL
07275	P1	ASIA ARMCHAIR PLAIN FABRIC	1		1
07276	P1	AISA SOFA 2 SEATS PLAIN FABRIC	1		1
07180	P1	CUSHION	1		1
07180	B1	CUSHION	1		1
04043	NE	THIERRY SET 3 PCS	1		1
04043	BI	THIERRY SET 3 PCS	1		1
02374	GS	KLEO COVER	1		1
09105	09	TERESA	1		1



NEW!

# FOUR EXTENDABLE 2024

Design Ferruccio Laviani

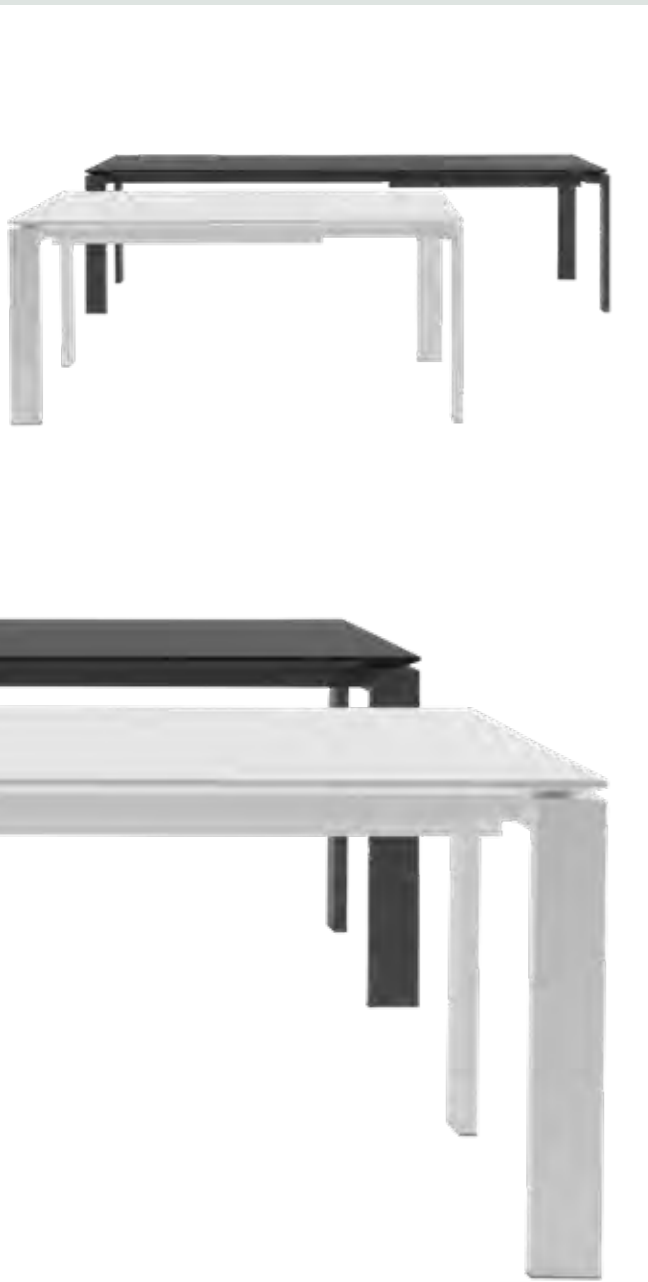

**4537**  
Soft touch extension table

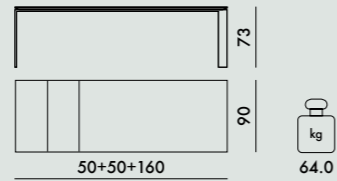

**LEGS**  
Painted steel

**TOP**  
Scratch-resistant soft-touch laminate



**6525**

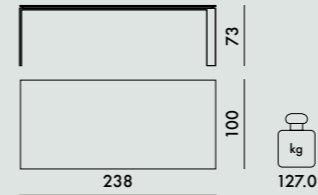

**LEGS**  
Painted steel

**TOP**  
Stoneware with marble finish

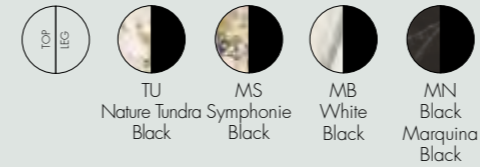

# FOUR XXL 2024

Design Ferruccio Laviani



NEW!



discover  
New Four Tables

EN 15372:2016	Level attained
5.1	Compliant
5.2	Compliant
EN 1730:2012	Level attained
6.2	(maximum level) 3
6.3	(maximum level) 3
6.4.2	(maximum level) 3
6.6	(maximum level) 3
6.9	(maximum level) 3
7.2	(maximum level) 3



<b>4537</b>	1 top	58.5	0.350	172X20X102
	1 structure	22.0	0.182	80X95X24

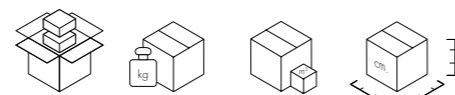

<b>6525</b>	1 top	100.4	0.202	256X7X114
	1 structure	40.9	0.256	101X105X24
	reinforcements	9.5	0.016	9X9X200

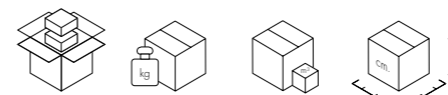

EN 15372:2016	Level attained
5.1	Compliant
5.2	Compliant
EN 1730:2012	Level attained
6.2	(maximum level) 3
6.3	(maximum level) 3
6.4.2	(maximum level) 3
6.6	(maximum level) 3
6.9	(maximum level) 3
7.2	(maximum level) 3



# LAYOUT 1FXL

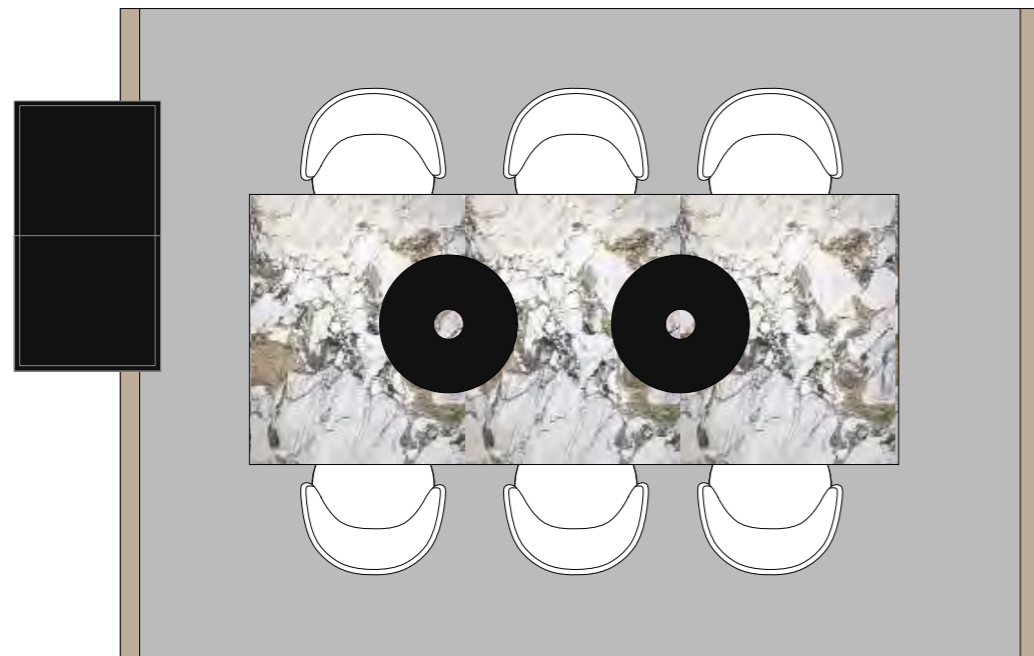
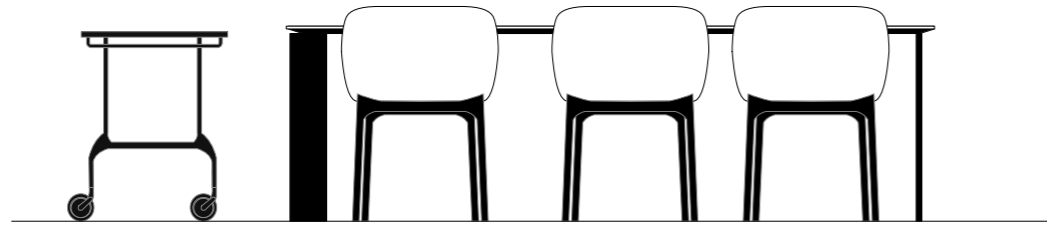
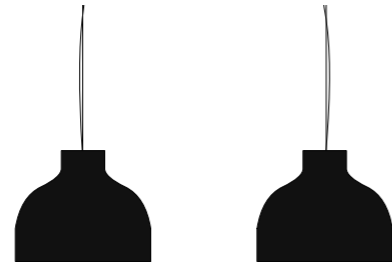

CODE	COLOR	DESCRIPTION	QTY LAYOUT	QTY PACK	TOTAL
04215	N1	CHARLA	6	0	6
06525	TU	FOUR XXL	1	0	1
09450	09	BELLISSIMA	2	0	2
04463	09	BATTISTA	1	0	1
01215	B4	I SHINE	1	0	1
02357	F9	KLIM	1	0	1
<b>ALTERNATIVE CHAIR</b>					
05886	NE	A.I.	6	0	6





# LAYOUT 1FEX

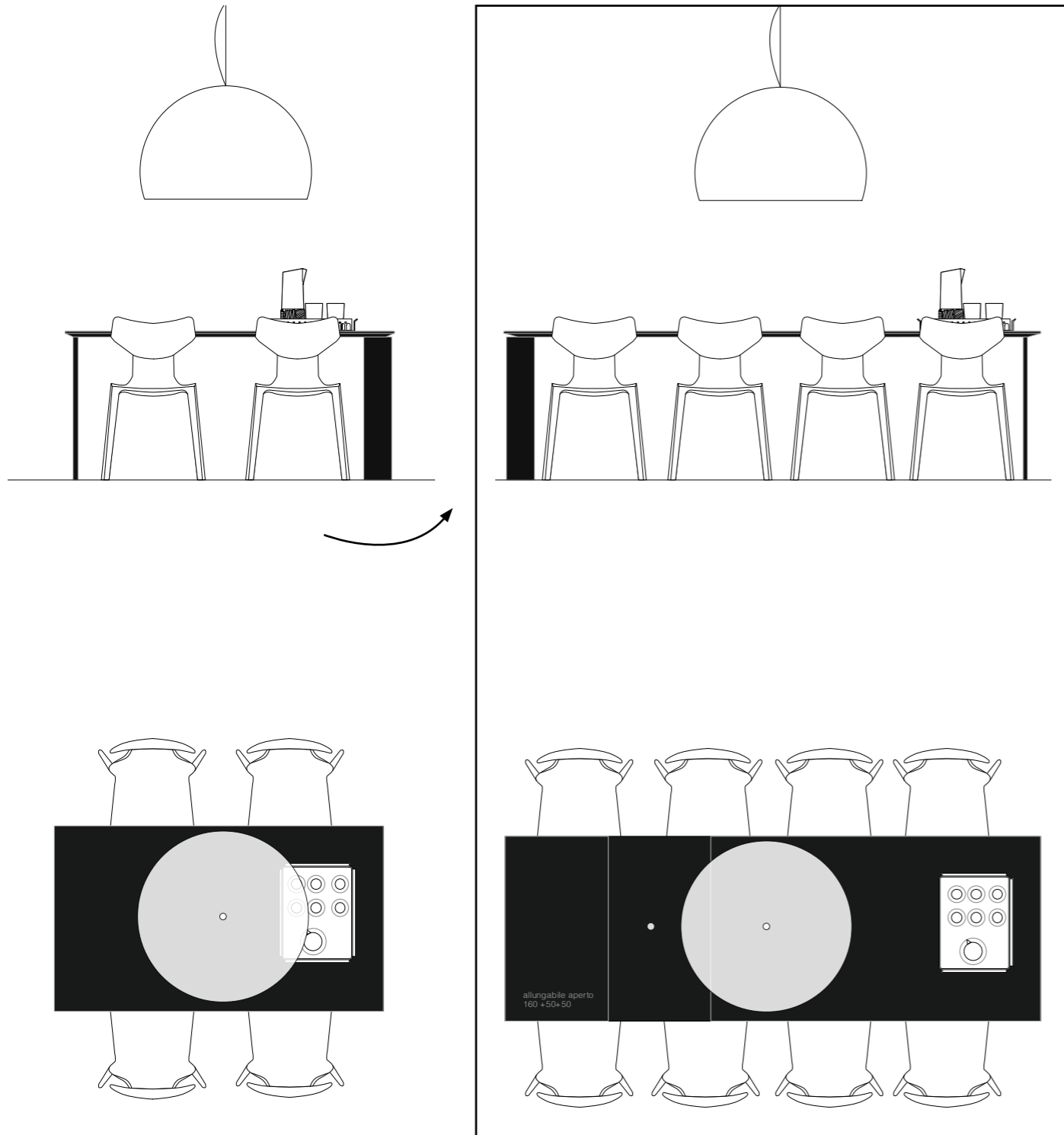

CODE	COLOR	DESCRIPTION	QTY LAYOUT	QTY PACK	TOTAL
04537	85	FOUR EXTENDABLE	1	0	1
05803	03	RE CHAIR	4	4	8
09058	03	BIG FLY	1	0	1
01441	03	PIAZZA	1	0	1
01490	B4	JELLIES CARAFE	1	0	1
01493	B4	JELLIES WINE GLASS	6	10	16



# LAYOUT 2FEX

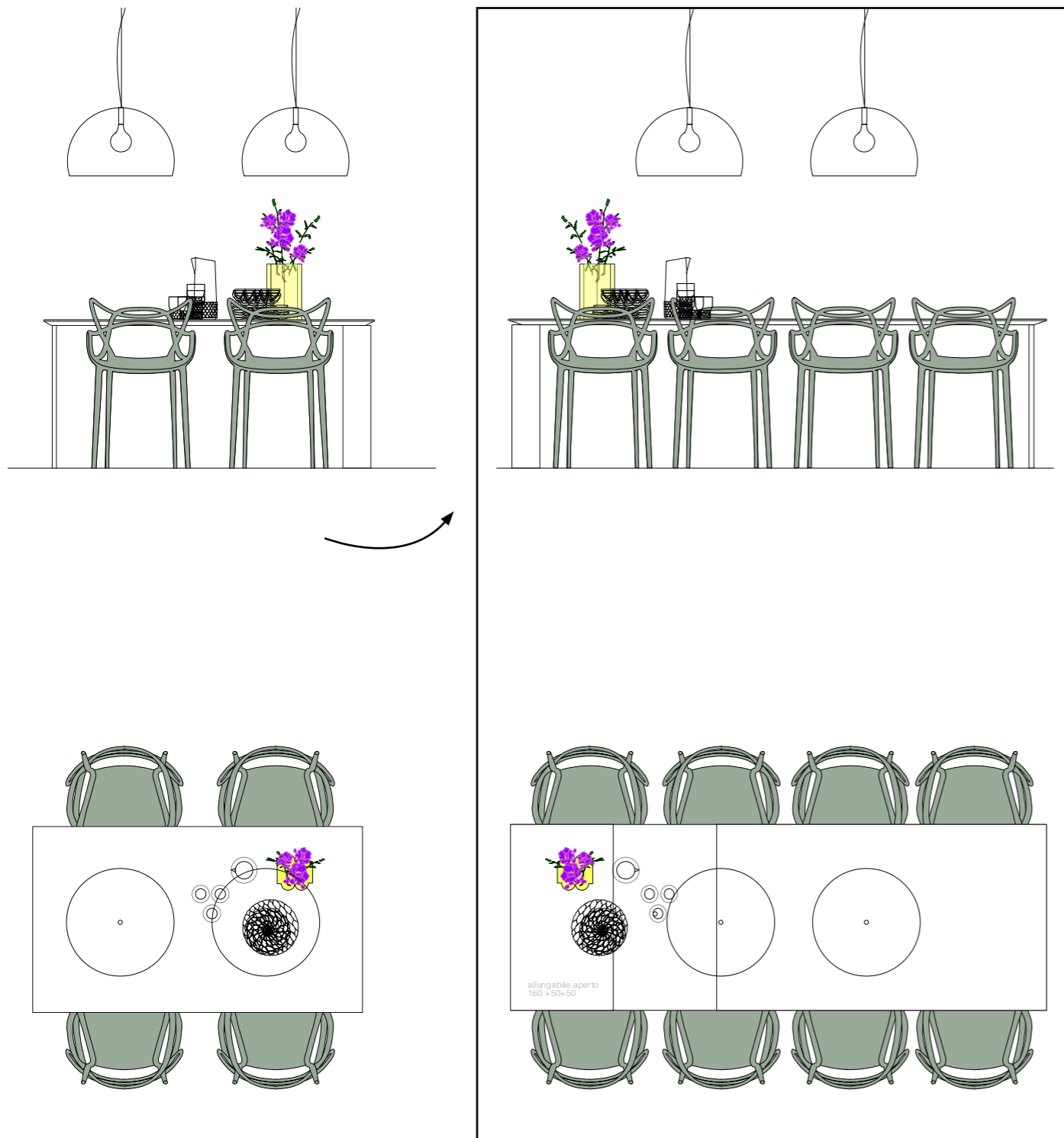

CODE	COLOR	DESCRIPTION	QTY LAYOUT	QTY PACK	TOTAL
04537	82	FOUR EXTENDABLE	1	0	1
05865	14	MASTERS	4	4	8
09030	B4	FL/Y	2	0	2
01584	03	OKRA	1	0	1
01495	B4	JELLIES PLATE	4	4	8
01496	B4	JELLIES PLATE	4	4	8
01490	B4	JELLIES CARAFE	1	0	1
01493	B4	JELLIES WINE GLASS	4	12	16



# GLOSSY XXL 2024

Design Antonio Citterio with Oliver Löw



- 4456**  
Chrome-plated steel frame
- 4457**  
White painted steel frame
- 4458**  
Black painted steel frame

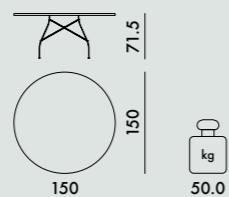

**FRAME**  
Chrome, gold-plated or painted steel



**TOP**  
Stoneware with marble finish



\*adjustable foot

# GLOSSY XXL OUTDOOR 2024

Design Antonio Citterio with Oliver Löw



**5580**

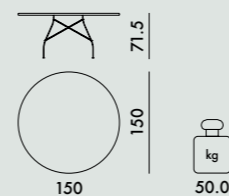

**5573**

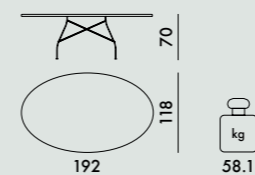

**FRAME**  
Painted steel

**TOP**  
Stoneware

Stoneware in solid colour

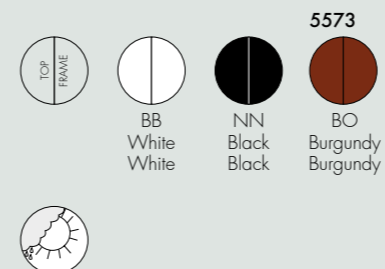

\*adjustable foot

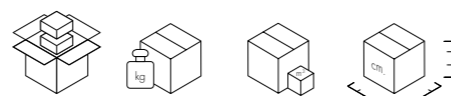

<b>4456/4457/4458</b>	1 top	52.0	0.192	155X155X8
	1 frame	8.39	0.107	80X74X18

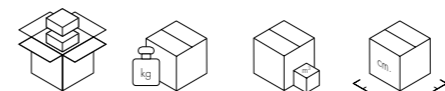

<b>5580</b>	1 top	52.0	0.192	155X155X8
	1 frame	8.39	0.107	80X74X18
<b>5573</b>	1 top	67.8	0.204	204X125X8
	1 frame	8.39	0.107	80X74X18





# LAYOUT 2GXL

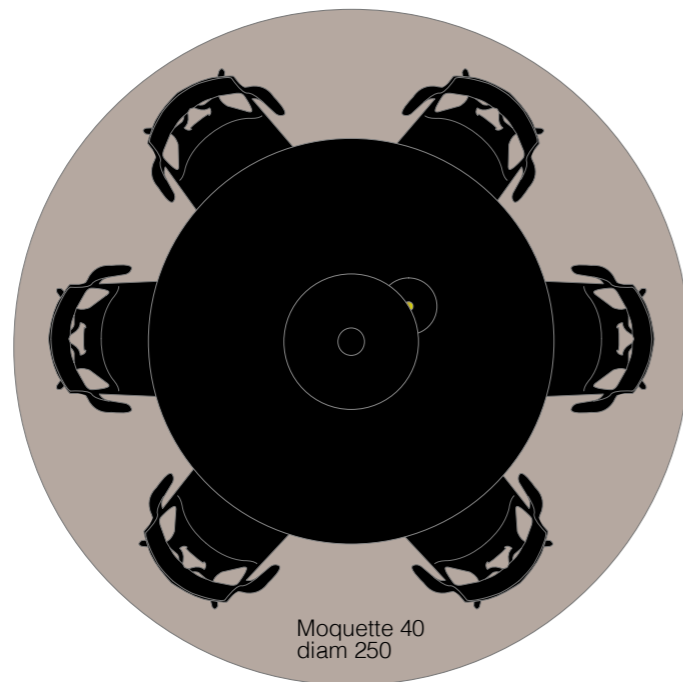

CODE	COLOR	DESCRIPTION	QTY LAYOUT	QTY PACK	TOTAL
09175	09	KABUKI SUSPENSION	1		1
05580	NN	GLOSSY XL	1		1
05886	NE	A.I.	6		6
09410	FU	MINI PLANET	1		1
01551	NF	PUMO	1		1
01955	CF	ABBRACCIAIO	2		2



**LAYOUT** 9GLO  
H.H.H. Upholstered Fabric version

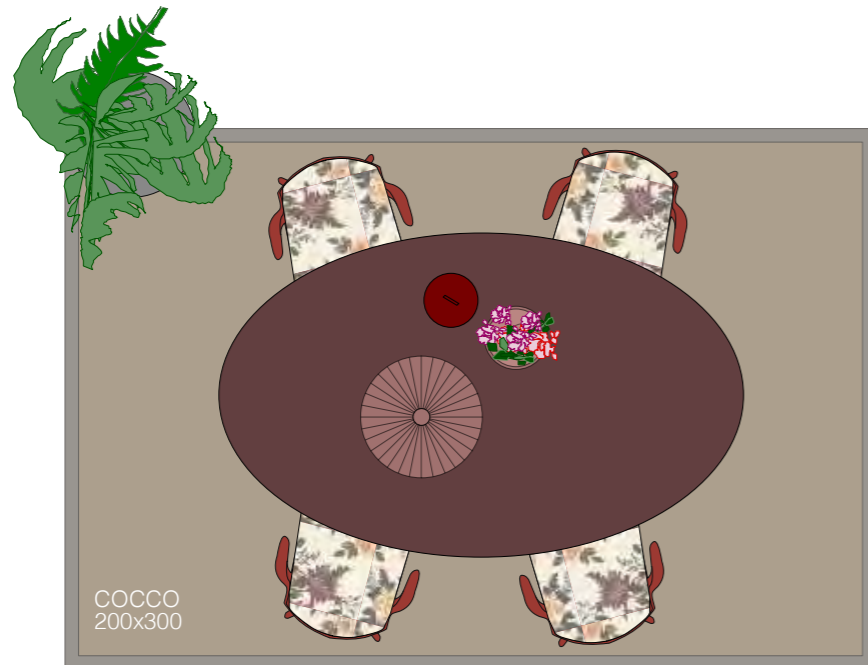

CODE	COLOR	DESCRIPTION	QTY LAYOUT	QTY PACK	TOTAL
05573	BO	GLOSSY XXL OUTDOOR	1		1
05918	XD	HHH UPHOLSTERED FABRIC	4		4
01226	E9	JELLY PLATE	1	3	4
01227	E9	JELLY VASE	1	1	2
09710	MA	MINI GEENA	1		1
02374	R1	KLEO COVER	1		1
<b>ALTERNATIVE CHAIR</b>					
05802	03	PIUMA	4		4



NEW!

# PLASTICS OUTDOOR 2024

Design Piero Lissoni

Kartell × LIBERTY.

6292

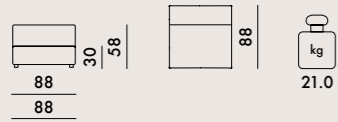

6294

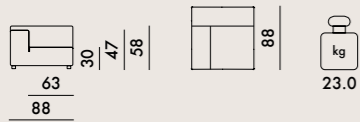

6296

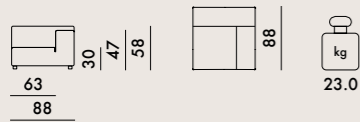

## SEAT AND BACK

Fabric-upholstered polyurethane

## UPHOLSTERY

Liberty® outdoor fabric

Tamba



6293



## POUF

Fabric-upholstered polyurethane

## UPHOLSTERY

Liberty® outdoor fabric

Obi Check



Artemis



7185

Cushion

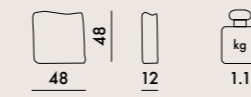

7186

Cushion



## MATERIAL

Batting lined with removable water-repellent Liberty® fabric.

Tamba



Obi Check

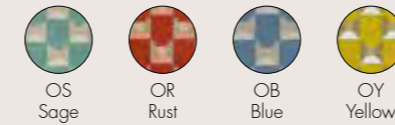

Artemis



6299

Protective cover

6300

Protective cover for pouf



Protective cover tutorial



EN 1022:1998	level reached
EN 1728:2000	Compliant
6.2.1	(maximum level) 5
6.2.2	(maximum level) 5
6.6	(maximum level) 5
6.7	(maximum level) 5
6.10	(maximum level) 5
6.15	(maximum level) 5
6.16	(maximum level) 5
6.17	(maximum level) 5

Item	Quantity	Weight (kg)	Volume (m³)	Dimensions (cm)
6293	1	24.0	0.305	92X36X92
6292	1	27.4	0.538	92X65X92
6294	1	31.0	0.562	93X65X93
6296	1	31.0	0.562	93X65X93
7185	1	1.85	0.039	51X51X15

Item	Quantity	Weight (kg)	Volume (m³)	Dimensions (cm)
6299	1	5.0	0.157	90X35X50
6300	1	5.0	0.157	90X35X50



# LAYOUT 1PLA

# outdoor



CODE	COLOR	DESCRIPTION	QTY LAYOUT	QTY PACK	TOTAL
06294	TS	PLASTIC OUTDOOR	1	0	1
06292	TS	PLASTIC OUTDOOR	2	0	2
06293	OS	PLASTIC OUTDOOR POUF	2	0	2
07185	TS	CUSHION	2	0	2
07185	OS	CUSHION	2	0	2
07185	AS	CUSHION	2	0	2
02374	GS	KLEO COVER	1	0	1
02373	GS	KLEO COVER	1	0	1
04154	MB	MULTIPLO LOW	1	0	1
09710	O3	MINI GEEN-A BATTERY	1	0	1
01441	O3	PIAZZA	1	0	1
01490	B4	JELLIES CARAFE	1	0	1
01493	B4	JELLIES WINE GLASS	4	12	16
05847	AS	CARA OUTDOOR MAT	2	0	2
02357	F9	KLIM	1	0	1

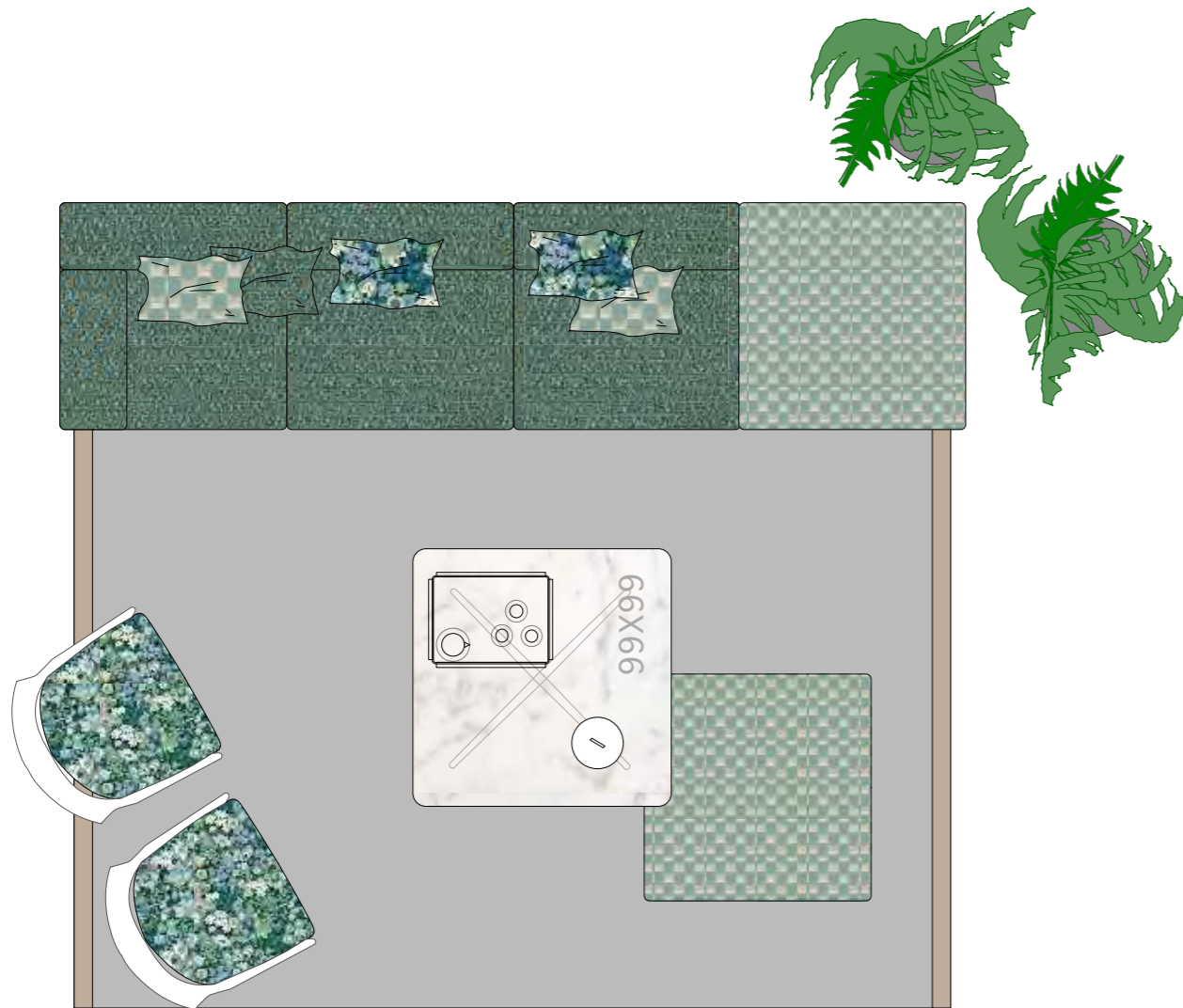



# LAYOUT 2PLA

# outdoor

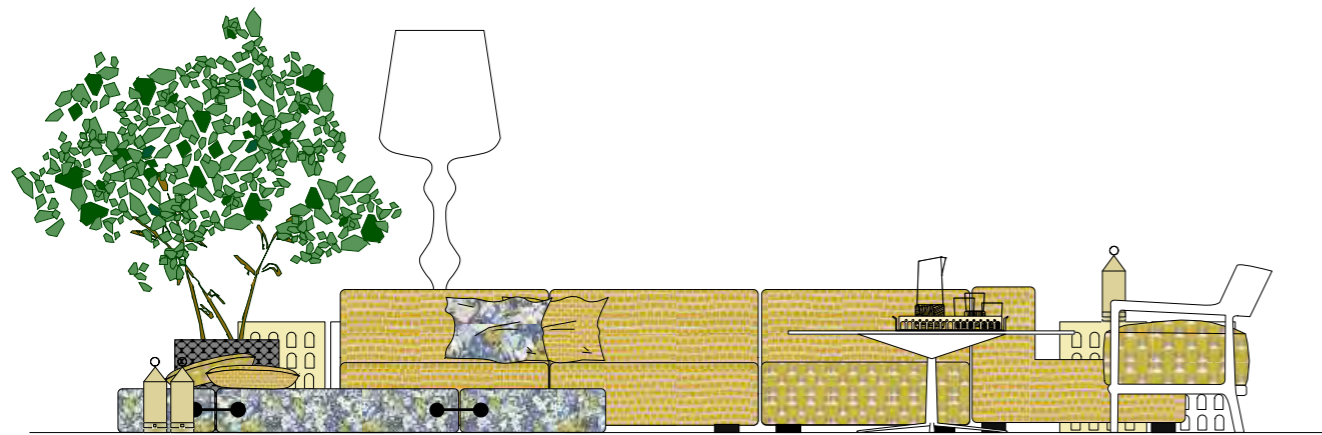

CODE	COLOR	DESCRIPTION	QTY LAYOUT	QTY PACK	TOTAL
06292	TY	PLASTIC OUTDOOR	5	0	5
06293	OY	PLASTIC OUTDOOR POUF	1	0	1
07185	TY	CUSHION	3	0	3
07185	OY	CUSHION	3	0	3
07185	AY	CUSHION	2	0	2
02374	GS	KLEO COVER	1	0	1
04152	MB	MULTIPLO LOW	1	0	1
09185	O3	KABUKI OUTDOOR	1	0	1
01441	DA	PIAZZA	1	0	1
01490	B4	JELLIES CARAFE	1	0	1
01493	B4	JELLIES WINE GLASS	4	12	16
09335	AM	LANTERN	4	0	4
05847	TY	CARA OUTDOOR MAT	2	0	2
06047	AY	TRIX	1	0	1
08855	TO	EUR	2	0	2
08855	O3	EUR	3	0	3

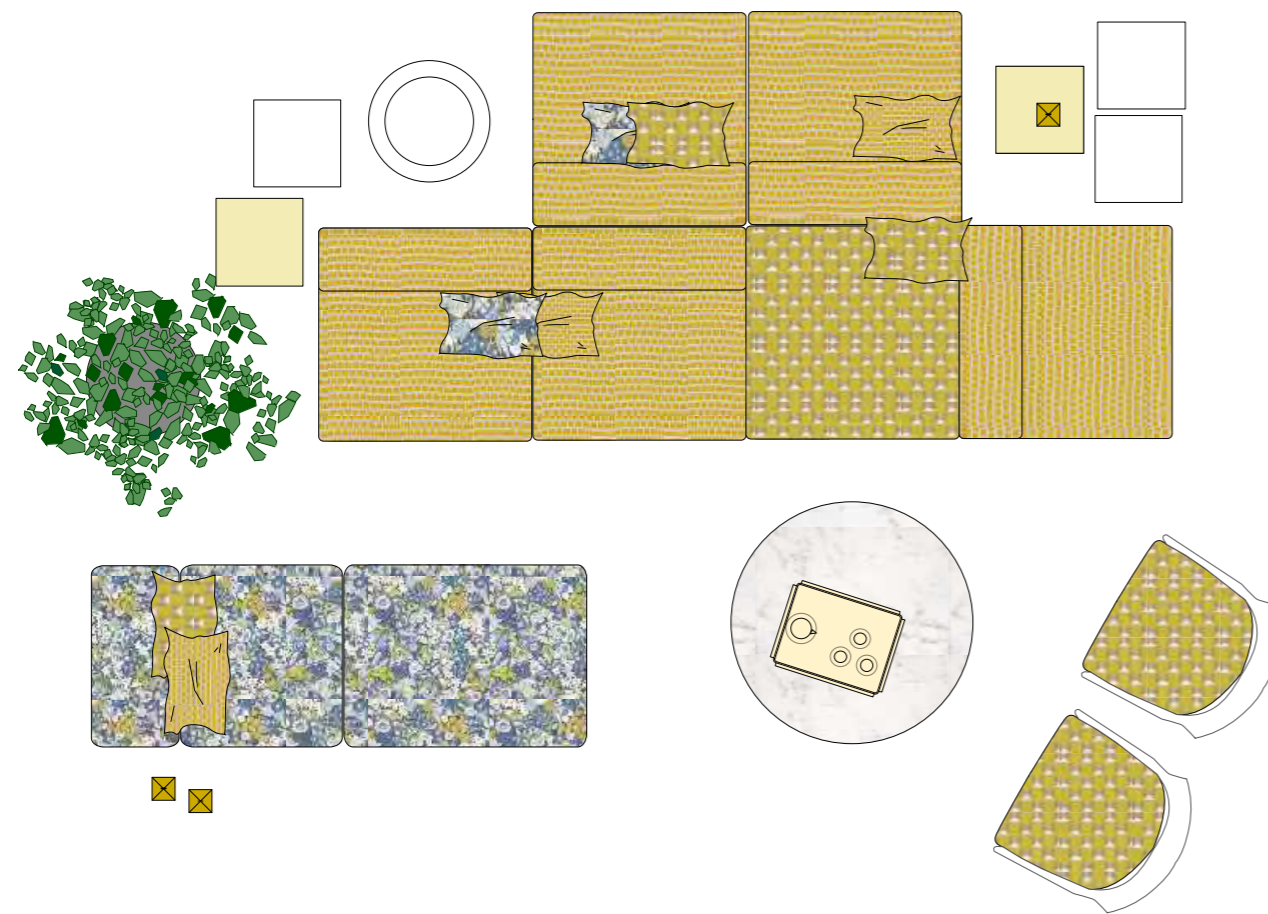



# LAYOUT 3PLA

# outdoor



CODE	COLOR	DESCRIPTION	QTY LAYOUT	QTY PACK	TOTAL
06294	TR	PLASTIC OUTDOOR SX	1		1
06292	TR	PLASTIC OUTDOOR	1		1
06293	OR	PLASTIC OUTDOOR POUF	2		2
06293	AR	PLASTIC OUTDOOR POUF	1		1
07185	TR	CUSHION	1		1
07185	AR	CUSHION	2		2
07185	OR	CUSHION	1		1
08855	O2	EUR	2		2
09710	MA	MINI GEEN-A BATTERY	2		2
09700	MA	GEEEN-A	1		1
02374	R1	KLEO	1		1
05000	B4	INVISIBLE SIDE	2		2

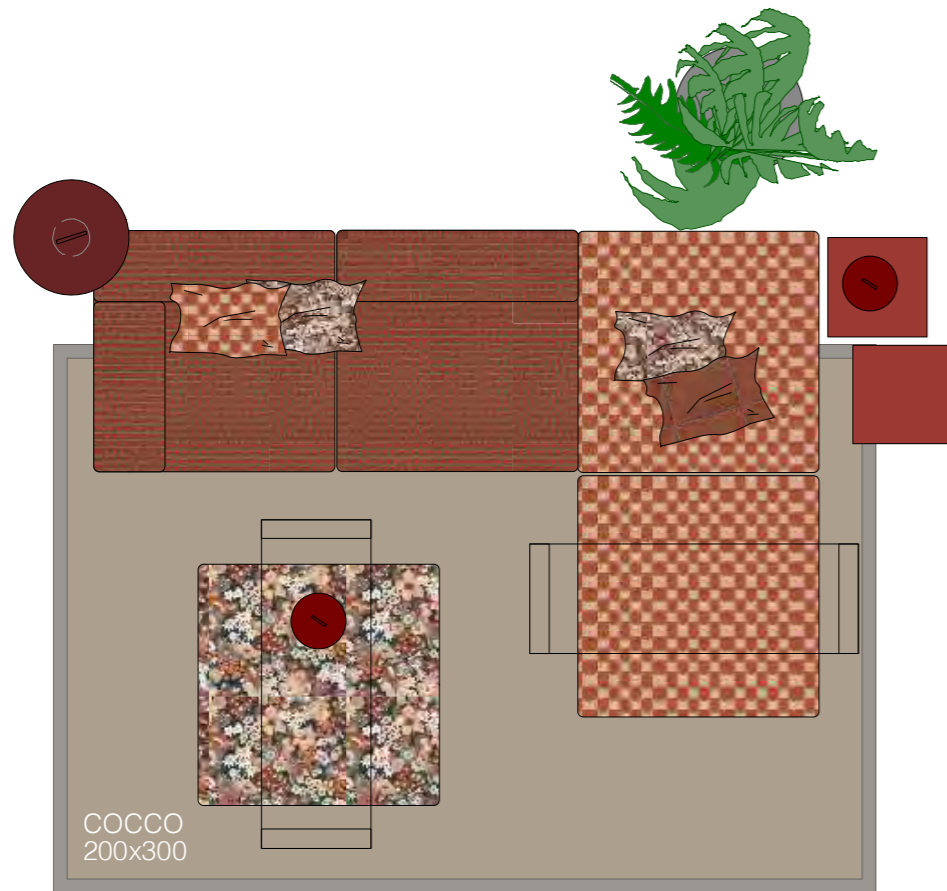



NEW!

# TRIX OUTDOOR 2024

Design Piero Lissoni

# Kartell × LIBERTY.



**6047**

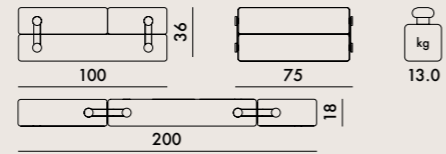

**MATERIAL**

Draining polyurethane coated in draining Liberty fabric with anti-slip bottom

**Obi Check**



**Artemis**

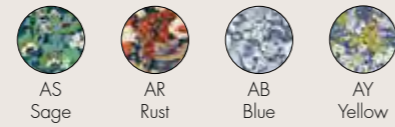

**7185**

Cushion

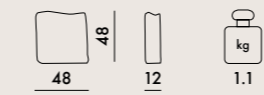

**7186**

Cushion

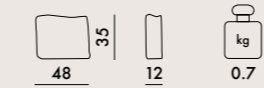

**MATERIAL**

Batting lined with removable water-repellent Liberty® fabric.

**Tamba**



**Obi Check**



**Artemis**

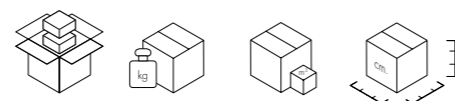
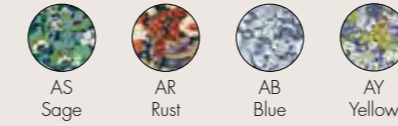

**6047**

1

14.6

0.376

103X44X83

# LAYOUT ITRX

# outdoor

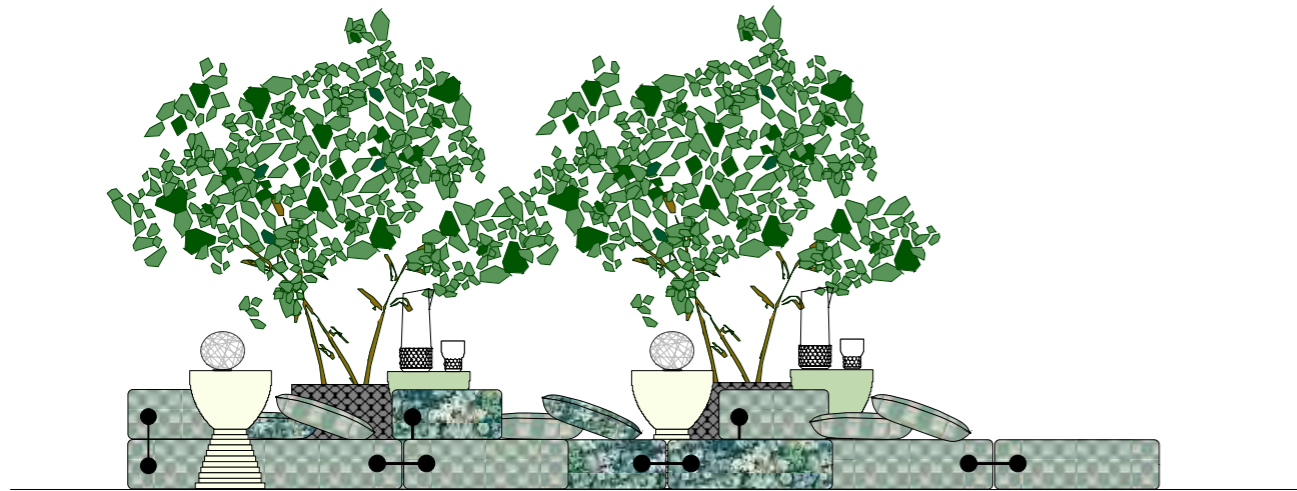

CODE	COLOR	DESCRIPTION	QTY LAYOUT	QTY PACK	TOTAL
06047	OS	TRIX	2	0	2
06047	AS	TRIX	1	0	1
02374	GS	KLEO COVER	1	0	1
02373	GS	KLEO COVER	1	0	1
07185	OS	CUSHION	1	0	1
07186	OS	CUSHION	2	0	2
07185	AS	CUSHION	2	0	2
07186	AS	CUSHION	1	0	1
08810	1N	PRINCE AHA	2	0	2
08810	4N	PRINCE AHA	2	0	2
01490	B4	JELLIES CARAFE	2	0	2
01493	B4	JELLIES WINE GLASS	2	14	16
09410	B4	MINI PLANET	2	0	2

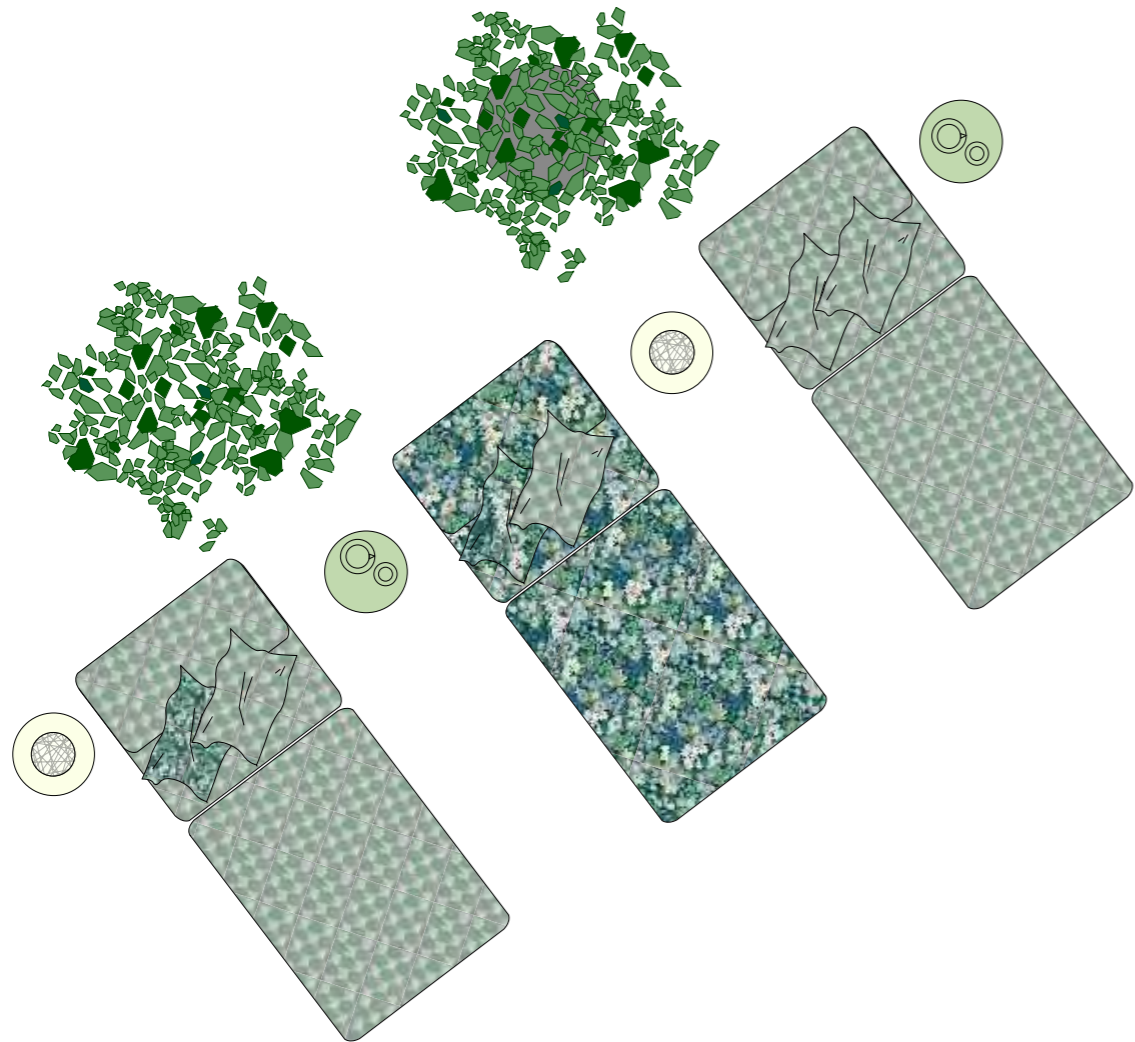



# LAYOUT 2TRX A/B

# outdoor

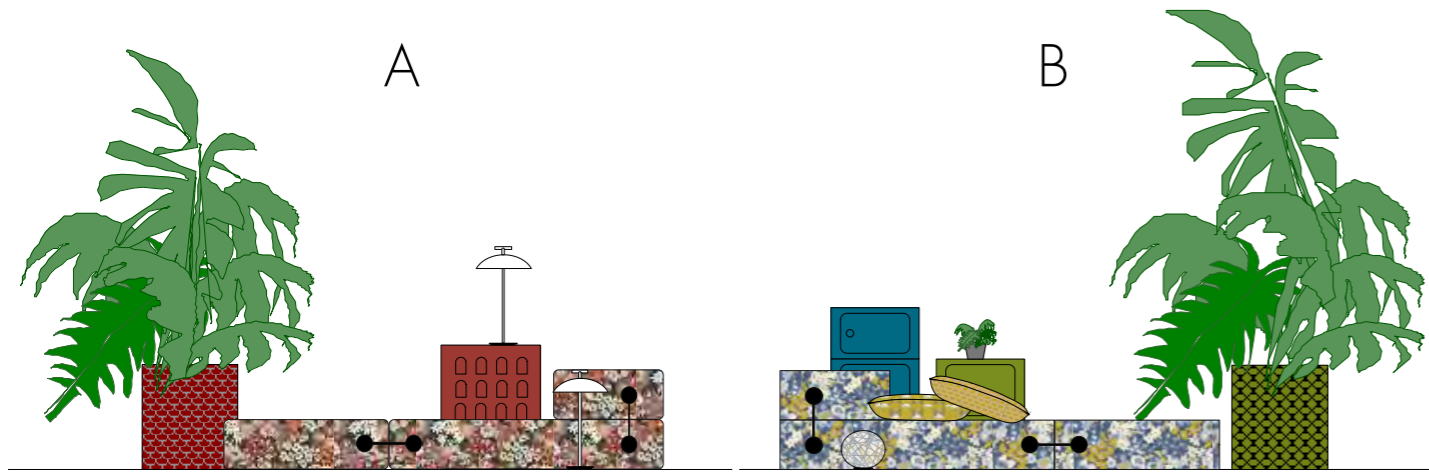

2TRX A					
CODE	COLOR	DESCRIPTION	QTY LAYOUT	QTY PACK	TOTAL
06047	AR	TRIX	1	0	1
02374	R1	KLEO COVER	1	0	1
02370	R1	KLEO CARPET	1	0	1
07185	OR	CUSHION	1	0	1
07186	OR	CUSHION	1	0	1
08855	O2	EUR	1	0	1
09710	O3	MINI GEEN-A	2	0	2

2TRX B					
CODE	COLOR	DESCRIPTION	QTY LAYOUT	QTY PACK	TOTAL
06047	AY	TRIX	1	0	1
02374	V1	KLEO COVER	1	0	1
02356	F9	KLIM	1	0	1
07185	OY	CUSHION	1	0	1
07186	TY	CUSHION	1	0	1
04966	18	COMPONIBILE 2	1	0	1
04967	15	COMPONIBILE 3	1	0	1
01490	B4	JELLIES CARAFE	1	0	1
01493	B4	JELLIES WINE GLASS	1	15	16
01495	B4	JELLIES PLATE	1	3	4
09410	B4	MINI PLANET	2	0	2

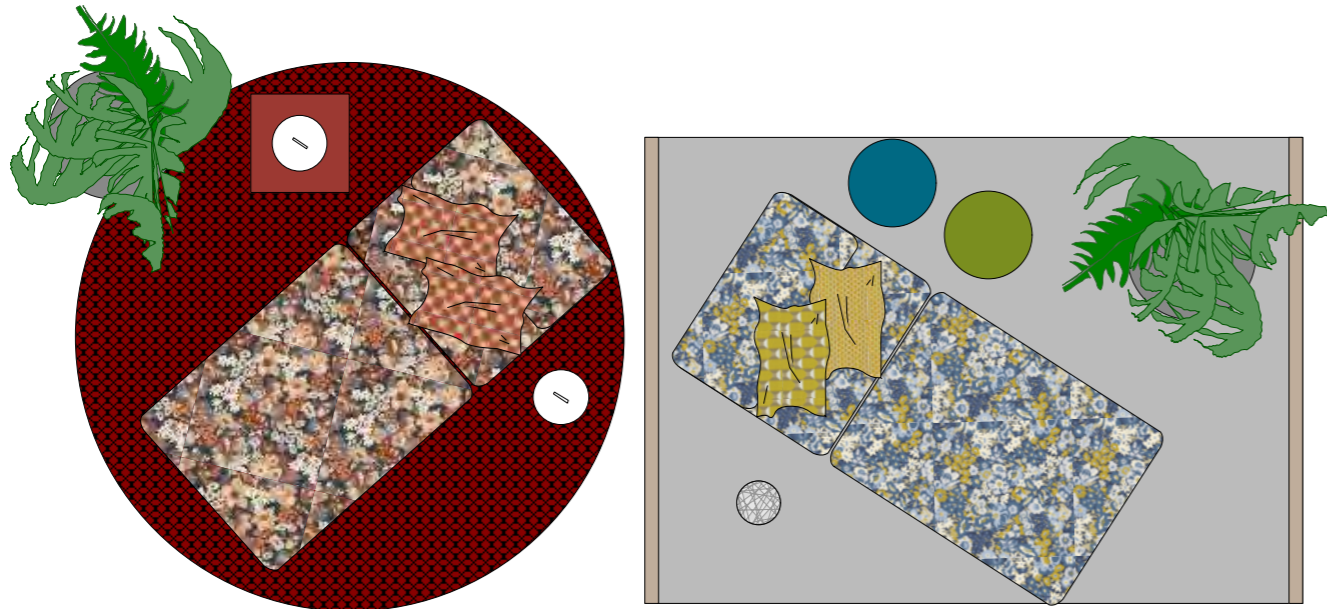



NEW!

# CARA OUTDOOR 2018

Design Philippe Starck with Sergio Schito

Kartell × LIBERTY.

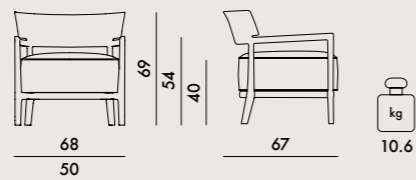

**FRAME**

Batch-dyed and painted polycarbonate with soft touch treatment.

**SEAT**

Draining polyurethane coated in draining Liberty fabric with anti-slip bottom

**5847**

Mat structure

**Tamba**

	TS	TR	TB	TY
	White Sage	White Rust	White Beige	White Yellow

**Obi Check**

	OS	OR	OB	OY
	White Sage	White Rust	White Blue	White Yellow

**Artemis**

	AS	AR	AB	AY
	White Sage	White Rust	White Blue	White Yellow

		Removable cover
--	--	-----------------



EN 1022:2005	level reached
EN 16139:2013+AC 2013	Compliant
EN 1728:2012+AC 2013	Compliant
6.4	L2
6.5	L2
6.6	L2
6.10	L2
6.11	L2
6.12	L2
6.15	L2
6.16	L2
6.17	L2
6.18	L2
6.20	L2
6.24	L2
6.25	L2
6.26	L2

<b>5847</b>		1	11.5		0.383		72X73X73
		1	4.2		0.105		65X65X25

# LAYOUT 12OUT

# outdoor



CODE	COLOR	DESCRIPTION	QTY LAYOUT	QTY PACK	TOTAL
02356	F8	KLIM	1	0	1
09180	AZ	KABUKI	1	0	1
05847	OB	CARA OUTDOOR MAT	2	0	2
07185	AB	CUSHION	2	0	2
02373	GS	KLEO COVER M	1	0	1
01490	E4	JELLIES CARAFE	1	0	1
01493	E4	JELLIES GLASS WINE	2	14	16
09475	AZ	BIG BATTERY	1	0	1
08810	1N	PRINCE AHA	2	0	2
08810	6N	PRINCE AHA	1	0	1

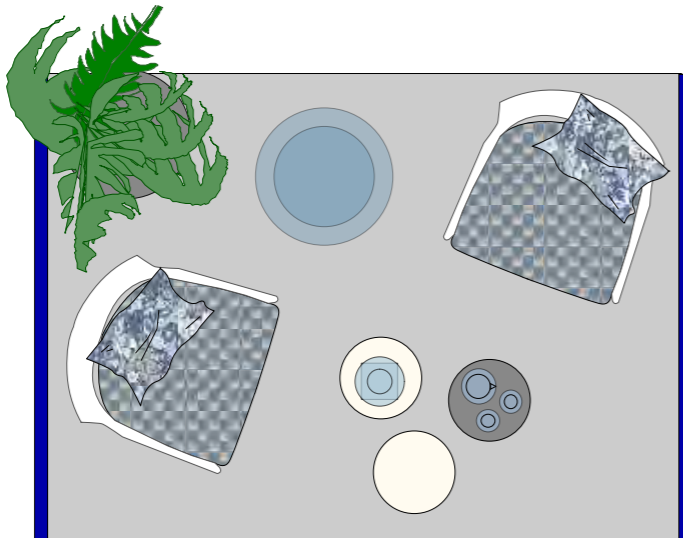





**K-WAITING** sofa/armchair  
des. R. Dordoni

**K-TOP** side table  
des. R. Dordoni

**K-LIM** carpet  
des. R. Dordoni

**K-LUX** floor lamp  
des. R. Dordoni

**GHOST BUSTER** dresser  
des. P. Starck with E. Quillet

**JELLY** vase  
des. P. Urquiola

**LIGHT-AIR** table lamp  
des. E. Quillet

**KLEO** cachepot  
des. L. Serafini+R. Palomba



NEW!

# K-TOP 2023

Design Rodolfo Dordoni



4297

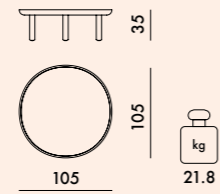

**FRAME**  
Polyester lacquered beech wood

**UNDERTOP**  
Polyester lacquered MDF

**TOP**  
Marble effect ceramic



4294

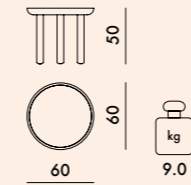

**FRAME**  
Polyester lacquered beech wood

**UNDERTOP**  
Polyester lacquered MDF

**TOP**  
Marble effect ceramic or coloured mirror

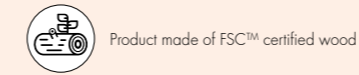
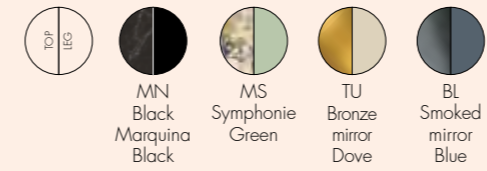

NEW!

# ANGELO STONE 2023

Design Philippe Starck



9400/B9400/U9400/Z9400

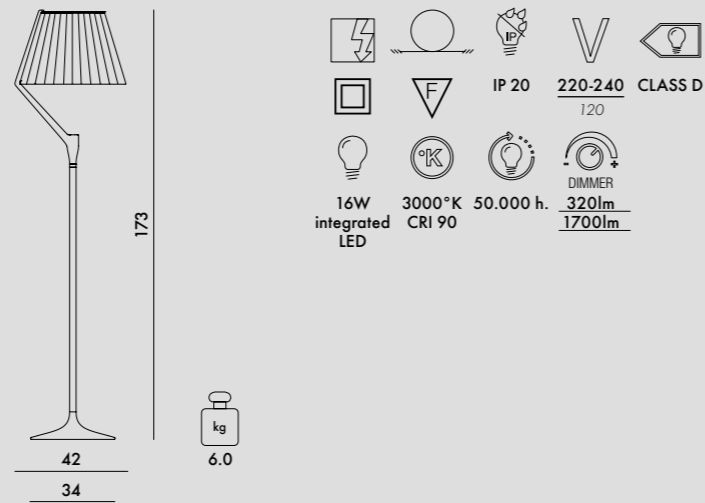

**FRAME**  
Liquid-painted die-cast aluminium

**DIFFUSER**  
Transparent thermoplastic technopolymer covered in fabric



**SPARE PART**

9400000  
LED Module  
9402000/9404000  
(vers. U9400)/9405000 (vers. Z9400)  
Power supply



discover Angelo Stone Unboxing tutorial

9405/B9405/U9405/Z9405

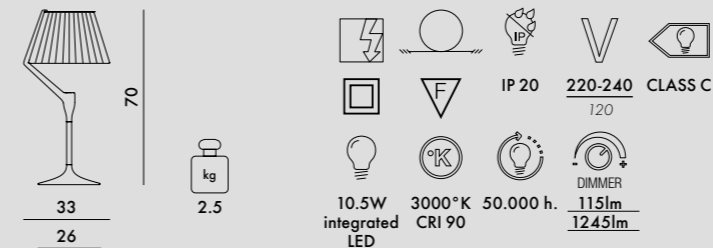

**FRAME**  
Liquid-painted die-cast aluminium

**DIFFUSER**  
Transparent thermoplastic technopolymer covered in fabric



**ANGELO STONE KEYPOINTS**

- Lamp with die-cast aluminum structure and diffuser made of molded polycarbonate covered in fabric: greater uniformity in light emission and absence of shadows generated by the metal supports of traditional lampshades.
- Lamp with indirect light emission with an LED source equipped with a lens specifically designed for reflection on the reflective aluminum screen inside the diffuser.
- Memory control for turning on after switching off: the lamp always returns to the previous intensity level after turning off, even in the event of a power outage.
- Dimmable with touch control.
- LED card long-life with 50,000 hours of use.
- 1700 lumens installed for the floor version, 1245 lumens for the table version
- Total recyclability of components at end of life, all separable.

**SPARE PART**

9405100  
LED Module  
9405200/9405300  
Power supply

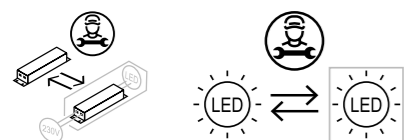

The light source and power supply element in this appliance must be replaced by qualified personnel only.

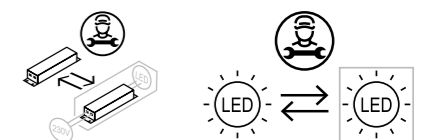

The light source and power supply element in this appliance must be replaced by qualified personnel only.

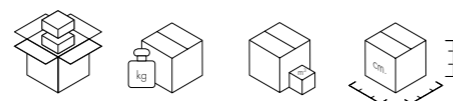

9400/B/U/Z 1 13.0 0.524 54X54X180

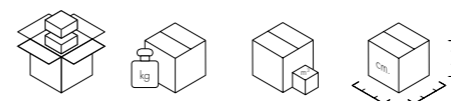

9405/B/U/Z 1 4.1 0.130 40X40X80



# LAYOUT 4FOC

CODE	COLOR	DESCRIPTION	QTY LAYOUT	QTY PACK	TOTAL
09400	BL	ANGELO STONE	1	0	1
09400	TT	ANGELO STONE	1	0	1
09400	RR	ANGELO STONE	1	0	1
09405	BL	ANGELO STONE TABLE	1	0	1
09405	TT	ANGELO STONE TABLE	1	0	1

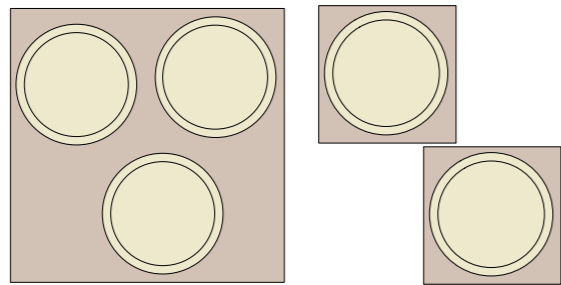
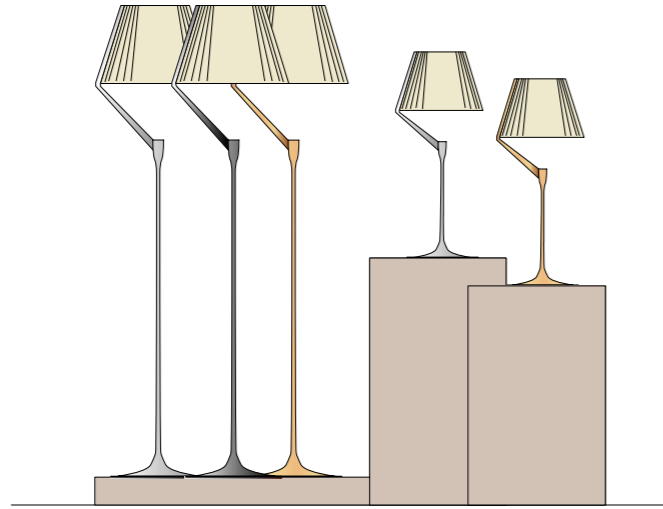



# LAYOUT 2STO

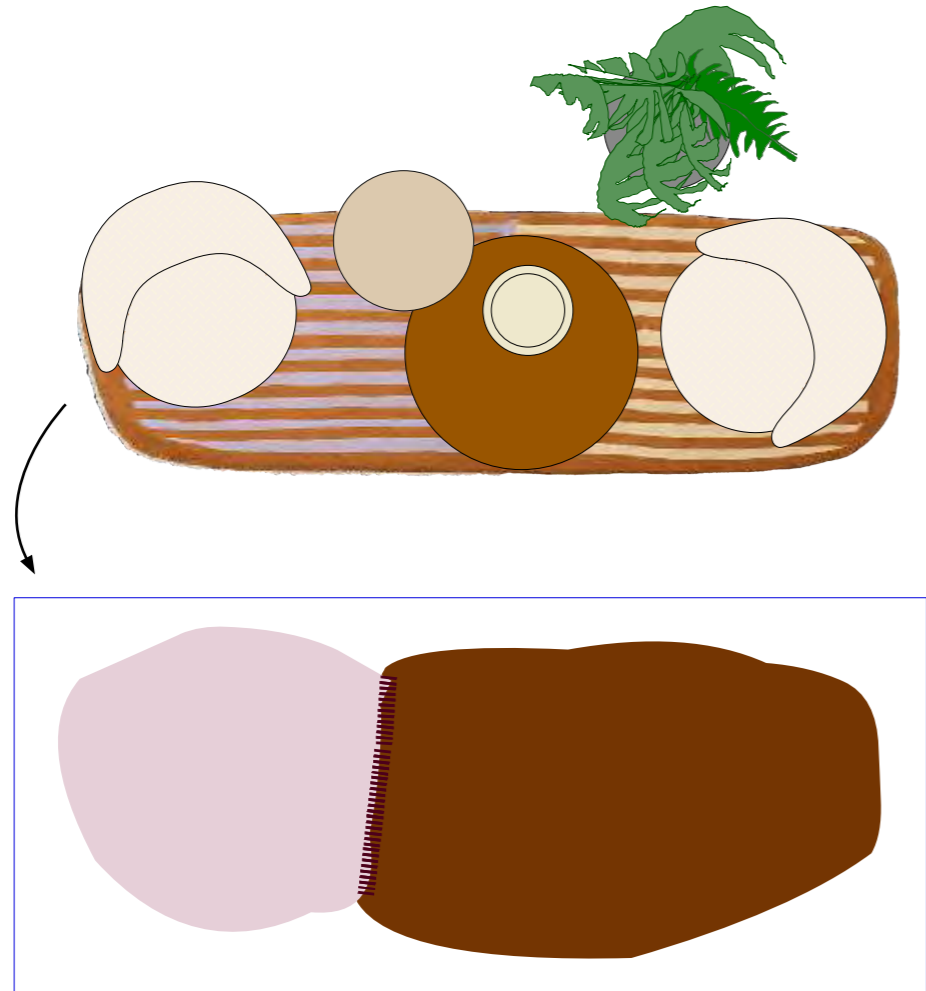

CODE	COLOR	DESCRIPTION	QTY LAYOUT	QTY PACK	TOTAL
06245	N1	LUNAM ARMCHAIR	2	0	2
04170	AR	UNDIQUE MAS	1	0	1
04168	RO	UNDIQUE MAS	1	0	1
09405	BL	ANGELO STONE TABLE	1	0	1
02373	GS	K-LEO COVER	1	0	1
02359	P2	CARPET	1	0	1
<b>ALTERNATIVE CARPET</b>					
02362	P8	CARPET	1		1



# LAYOUT 8GLO

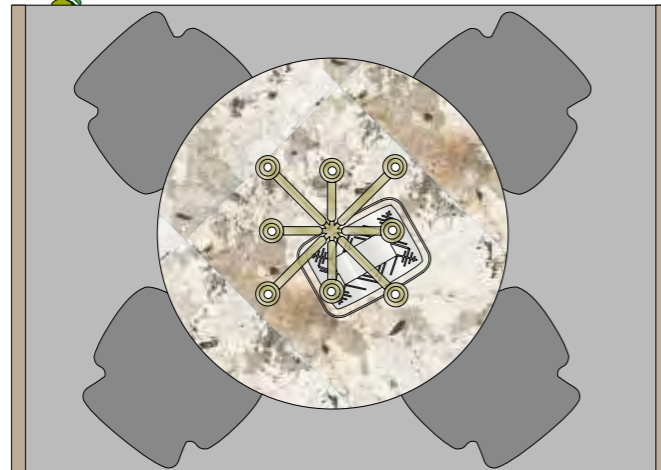
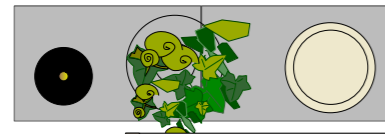

CODE	COLOR	DESCRIPTION	QTY LAYOUT	QTY PACK	TOTAL
G9550	B4	KHAN	1		1
04578	TU	GLOSSY TUNDRA ROUND	1		1
05802	GR	PIUMA	4		4
01965	XX	TEATIME	1		1
03210	V9	GHOST BUSTER	2		2
09405	TT	ANGELO STONE TAVOLO	1		1
01551	NF	PUMO	1		1
01229	B4	SHANGHAI	1		1
02356	F9	KLIM	1		1



NEW!

# AALAND 2024

Design Patricia Urquiola



# PLANET 2016

Design Tokujin Yoshioka



**2362**

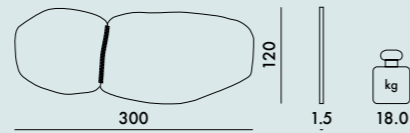

**2363**

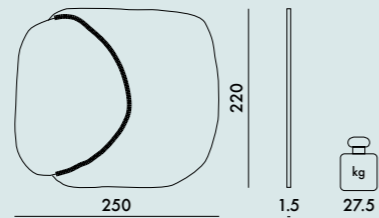

**2361**

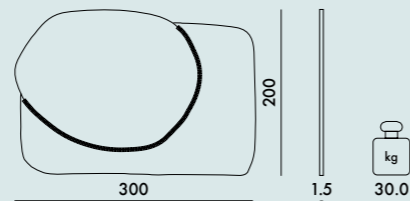

**MATERIAL**

Hand-tufted and hand-cut Himalayan wool, vegetable and mineral dyes



**9430**

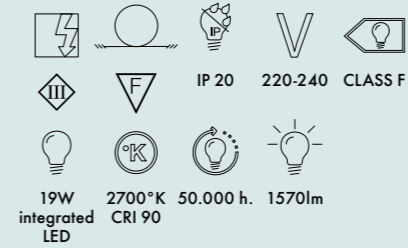
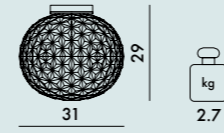

**FRAME**

Polished or painted die-cast aluminium

**DIFFUSER**

Transparent or mass-dyed thermoplastic technopolymer

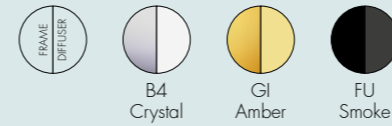

**SPARE PART**

**9386000**  
LED Module



discover Planet Family



<b>2362</b>	1	20.00	0.101	130X28X28
<b>2363</b>	1	29.5	0.207	230X30X30
<b>2361</b>	1	31.00	0.257	210X35X35

<b>9430</b>	1	4.2	0.05	39X33X39
-------------	---	-----	------	----------

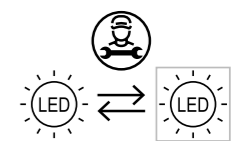

The light source contained in this appliance must only be replaced by qualified personnel using original spare parts.





**Kartell**  
Milano