



2024



**mm**lampadari



# META-

# MMM

PER LA NUOVA EDIZIONE DEL NOSTRO CATALOGO ABBIAMO PENSATO FOSSE ORMAI DIVENTATO LIMITANTE PENSARE A DUE SOLE COLLEZIONI INTESTANDOLE A UN TEMA CLASSICO E A UN TEMA DESIGN: LE SFUMATURE PROGETTUALI SONO INFINITE, E LA NOSTRA ATTENZIONE AL PRODOTTO CI HA PORTATO A RICONSIDERARE LA STESSA SEMANTICA DELLE COLLEZIONI PER CONDENSARLE IN VISIONI, PIÙ CHE AGGETTIVI, E TRASFERIRE QUINDI ALL'OSSERVATORE UN'ESPERIENZA DI PRODOTTO, ANZICHÉ APPROSSIMARLA IN UN ATTRIBUTO. IL CATALOGO CHE STATE SFOGLIANDO È FRUTTO DI UNA METICOLOSA REVISIONE DI QUANTO MM HA CREATO NEGLI ANNI, OPERATA PENSANDO ALL'HABITAT, ALLA PERSONALITÀ E ALLO STILE DI VITA CHE ABBIAMO IMMAGINATO CARATTERIZZARE I NOSTRI CLIENTI.

SI PARLA SPESSO DI DNA AZIENDALE, MA ALTRETTANTO SOVENTE SI DIMENTICA CHE IN TERMINI BIOLOGICI IL DNA È SOGGETTO A UNA CONTINUA MUTAZIONE, UN TENTATIVO DELLA NATURA DI PROVARE STRADE NUOVE E MAI PERCORSE: IL CATALOGO M.MM È ESATTAMENTE UNA MUTAZIONE DI STANDARD, UNA IMPROVVISAZIONE SU UN TEMA CHE L'ORCHESTRA CONOSCE MOLTO BENE, MA CHE MERITA CONTINUA SPECULAZIONE, ANALISI, RINCORSA. IN QUESTA COLLEZIONE DESIDERIAMO MOSTRARVI DOVE CI HA PORTATO LA NOSTRA RICERCA.

FOR THE NEW EDITION OF OUR CATALOG WE THOUGHT IT HAD NOW BECOME LIMITING TO THINK OF JUST TWO COLLECTIONS, NAMING THEM WITH A CLASSIC THEME AND A DESIGN THEME: THE DESIGN NUANCES ARE INFINITE, AND OUR ATTENTION TO THE PRODUCT HAS LED US TO RECONSIDER THE VERY SEMANTICS OF THE COLLECTIONS TO CONDENSE THEM INTO VISIONS, RATHER THAN ADJECTIVES, AND THEREFORE TRANSFER A PRODUCT EXPERIENCE TO THE OBSERVER, RATHER THAN APPROXIMATING IT IN AN ATTRIBUTE. THE CATALOG YOU ARE BROWSING IS THE RESULT OF A METICULOUS REVIEW OF WHAT MM HAS CREATED OVER THE YEARS, CARRIED OUT THINKING ABOUT THE HABITAT, PERSONALITY AND LIFESTYLE THAT WE IMAGINED CHARACTERIZING OUR CUSTOMERS.

WE OFTEN TALK ABOUT CORPORATE DNA, BUT EQUALLY OFTEN WE FORGET THAT IN BIOLOGICAL TERMS DNA IS SUBJECT TO CONTINUOUS MUTATION, AN ATTEMPT BY NATURE TO TRY NEW AND NEVER-TRODDEN PATHS: THE M.MM CATALOG IS EXACTLY A MUTATION OF STANDARDS, A IMPROVISATION ON A THEME THAT THE ORCHESTRA KNOWS VERY WELL, BUT WHICH DESERVES CONTINUOUS SPECULATION, ANALYSIS AND PURSUIT. IN THIS COLLECTION WE WANT TO SHOW YOU WHERE OUR RESEARCH HAS TAKEN US.

# DA OLTRE 50 ANNI INTERPRETIAMO LA MATERIA PER CREARE OPERE DI LUCE

MM LAMPADARI NASCE NEL 1966, MEZZO SECOLO CHE CI HA VISTI CRESCERE E DIVENTARE UNA TRA LE PIÙ IMPORTANTI REALTÀ ITALIANE NEL SETTORE DELL'ILLUMINAZIONE D'INTERNI A LIVELLO INTERNAZIONALE. QUELLO CHE CI CONTRADDISTINGUE È LA GRANDE ABILITÀ DI PLASMARE LA MATERIA SECONDO LE TRADIZIONALI TECNICHE DI LAVORAZIONE DEL FERRO, CHE ANCORA OGGI VIENE BATTUTO A MANO DA ESPERTI ARTIGIANI.

LO STILE MM LAMPADARI È UNO STILE BEN DEFINITO, IL NOSTRO È UN LAVORO FATTO CON PASSIONE CHE CREA VERE E PROPRIE OPERE D'ARTE ARTIGIANA PER ILLUMINARE OGNI AMBIENTE CON GUSTO E UNICITÀ. SIAMO STILISTI DELL'ILLUMINAZIONE, CAPACI DI FONDERE IN UN'UNICA CREAZIONE IL METALLO E IL VETRO DI MURANO. SIAMO CUSTODI DI UN SAPERE ANTICO MA SAPPIAMO GUARDARE ANCHE AL FUTURO PROPONENDO PEZZI STORICI IN CHIAVE MODERNA E REALIZZAZIONI DAL GUSTO PURAMENTE CONTEMPORANEO.



# WE'VE BEEN SHAPING RAW MATERIALS TO CREATE LIGHT ARTWORKS FOR MORE THAN 50YRS

MM LAMPADARI WAS FOUNDED IN 1966, AND FOR MORE THAN HALF A CENTURY WE HAVE BEEN GROWING AND EXPANDING OURSELVES, BECOMING ONE OF THE MOST IMPORTANT REALITY OF THE ITALIAN LIGHTING FIELD ON AN INTERNATIONAL LEVEL. OUR GREAT ABILITY TO SHAPE IRON THROUGH TRADITIONAL TECHNIQUES AND THE WORK OF EXPERTS IS WHAT MAKES STAND US OUT. MM LAMPADARI WELL-DEFINED STYLE AND THE PASSION WE PUT INTO OUR CREATIONS ARE THE THINGS THAT MAKE US CREATE HANDCRAFTED MASTERPIECES.

WE ARE LIGHTING DESIGNERS, ABLE TO MELT TOGETHER METAL AND MURANO GLASS.

OUR AIM IS THE ONE OF ILLUMINATING EVERY SPACE WITH STYLE AND DISTINCTIVENESS, LEARNING FROM OUR PAST TRADITIONS BUT ALWAYS LOOKING AT THE FUTURE, OFFERING PAST DESIGNS THROUGH MODERN SHAPES AND CONTEMPORARY REALIZATIONS.

## GLI OPPOSTI SI FONDONO IN PERFETTA ARMONIA

I PROTAGONISTI DELLE REALIZZAZIONI MM LAMPADARI SONO DA SEMPRE DUE MATERIALI CONSIDERATI AGLI ANTIPODI TRA LORO: IL VETRO SOFFIATO E IL FERRO FORGIATO A MANO. SONO MOLTI GLI ELEMENTI CHE LI ACCOMUNANO, UNA TRA TUTTI L'ABILITÀ CHE NECESSITANO PER ESSERE LAVORATI. MM LAMPADARI HA FATTO TESORO DI ANNI DI ESPERIENZA, HA RACCOLTO I MIGLIORI ARTIGIANI E CON LORO HA CARPITO I SEGRETI DELLA LAVORAZIONE FATTA A MANO DEL FERRO E DEL VETRO. I RISULTATI SONO PRODOTTI IN CUI L'ARMONIA TRA I MATERIALI SPICCA FIN DAL PRIMO SGUARDO. I NOSTRI MAESTRI ARTIGIANI SANNO COME CREARE EQUILIBRIO TRA PIENO E VUOTO, TRA LEGGEREZZA E SOLIDITÀ. CONOSCONO LE ANTICHE TECNICHE CHE PERMETTONO DI FONDERE IL VETRO NEL METALLO, CREANDO UN UNICO CORPO PERFETTAMENTE BILANCIATO. QUESTA UNIONE È SEMPRE ALLA BASE DELLE REALIZZAZIONI DELL'AZIENDA CHE L'HA DECLINATA SIA NEGLI STILI PIÙ CLASSICI, SIA IN FORME PIÙ INNOVATIVE E DALLA NUOVA CONCEZIONE ESTETICA.



## OPPOSITES MELT TOGETHER IN HARMONY

HANDMADE FORGED-IRON AND BLOWN GLASS: THESE ARE THE MAIN ELEMENTS OF OUR PRODUCTS. DIFFERENT ELEMENTS WITH SAME NEEDS, AS THE EXPERIENCE REQUIRED TO SHAPE THEM. MM LAMPADARI, WITH ITS LONG-LASTING EXPERIENCE AND BEST ARTISANS CREATES HARMONY BETWEEN OPPOSITES, BALANCING EMPTINESS AND FULLNESS, LIGHTNESS AND SOLIDITY. WE KNOW ALL ANCIENT TECHNIQUES THAT ALLOW US TO MELT IRON AND GLASS TOGETHER, CREATING PERFECTLY BALANCED SHAPES. THIS UNION HAS ALWAYS BEEN THE BASIS FOR OUR REALIZATIONS, APPLYING IT TO BOTH OUR CLASSIC AND INNOVATIVE DESIGNS, CREATING A NEW AESTHETIC VISION.

## MM LAMPADARI, UN PONTE TRA TRADIZIONE E MODERNITÀ

IN QUESTA EDIZIONE DEL NOSTRO CATALOGO ABBIAMO VO- LUTO ME"ERE IN EVIDENZA LE NOSTRE DUE ANIME: UNA MOLTO FO!E LEGATA ALLA TRADIZIONE, AD UN SAPERE ANTICO DI CUI SIAMO CUSTODI, L'ALTRA CHE GUARDA AL FUTURO PER TRAGHE"ARE NELL'ERA CONTEMPORANEA IL GUSTO CLASSICO DEL PASSATO. PER QUESTO ABBIAMO CREATO DUE SEZIONI DISTINTE NEL CATALOGO, UNA DEDICATA ALLE RAFFINATE LINEE CLASSICHE E UNA CHE ME"È IN MOSTRA LE NOSTRE REINTERPRETAZIO- NI DEI CANONI TRADIZIONALI, PER RACCONTARE A"RAVERSO I PRODO" I E A"RAVERSO LA LUCE QUESTI DUE VOLTI DELLA NO- STRA AZIENDA, DOVE L'EQUILIBRIO TRA LE PAII È DA SEMPRE LA NOSTRA PAROLA D'ORDINE.



## MM LAPADARI, A BRIDGE BETWEEN TRADITION AND MODERNITY

THIS NEW EDITION OF OUR CATALOGUE HIGHLIGHTS OUR DOU- BLE NATURE: THE STRONG SOUL LINKED TO OUR TRADITIONS AND PAST KNOWLEDGE, AND THE INNOVATIVE ONE THAT LOOKS AT THE FUTURE TO LEAD CLASSIC DESIGNS THROUGH CONTEM- PORANEITY. FOR THIS REASON, WE SEPARATED THE CATALOGUE INTO TWO PAIS: ONE FOCUSED ON THE CLASSIC DESIGNS AND THE OTHER ONE, WHICH SHOWS OUR MODERN INTERPRETATIONS OF CLASSIC STANDARDS. ALL OF THIS HAS BEEN MADE TO SHOW HOW IMPO!ANT BALANCING DIFFERENT STYLE IS FOR US AND OUR PRODUCTS

# INDEX



TRIGON 16



CHOOPS 20



MYA POP 26



TILTLIT 30



LOOP 34



ARCH 38



CLESSIDRA 50

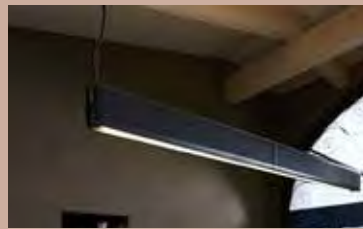

CODE 58



DOTS 64



ARIA 72



PAPILLON 78



MOONLIGHT 86



BELLA TUBE 96



RIPPLE 102



BALLOON 108



BALLOTON 114



CHILL 124



LAYLA 132



LEAF 136



MAESTRO 144



MATA 150



MILA 156



PINEAPPLE 162



RAIN 168



WHALE 178



KINGDOM 184



PARAMOUNT 192

# TRIGON

DESIGNED BY MM LAMPADARI WORKSHOP





# TRIGON

Le curve della superficie  
vetrosa sembrano suggerire  
di accarezzarla, percepirne le  
sinuosità, ascoltare il rumore  
prodotto dalla pelle contro  
le pareti, impercettibilmente  
ruvide per massimizzare  
la dispersione della luce e  
creare un morbido effetto  
luminoso.

*The curves of the glassy  
surface seem to suggest  
caressing it, perceiving  
its sinuosities, listening  
to the noise produced by  
the skin against the walls,  
impercetibly rough to  
maximize the dispersion  
of light and create a soft  
luminous effect.*



# CHOOPS

DESIGNED BY GIORGIO BISCARO



# CHOOPS

La perfezione del metallo tornito, enfatizzata dalla finitura liscia e lucente, abbinata alla cristallina trasparenza del vetro prismatico rendono Choops un solido elemento visivo, perfetto nella forma e nella coniugazione dei volumi. Richiamo affettuoso al design Space Age degli anni '70, lo reinterpreta in chiave squisitamente contemporanea.

*The perfection of spun metal, emphasized by the smooth and shiny finish, combined with the crystalline transparency of the prismatic glass make Choops a solid visual element, perfect in its shape and in the combination of its volumes. An affectionate reference to the Space Age design of the 70s, it provides a new, contemporary take on it.*



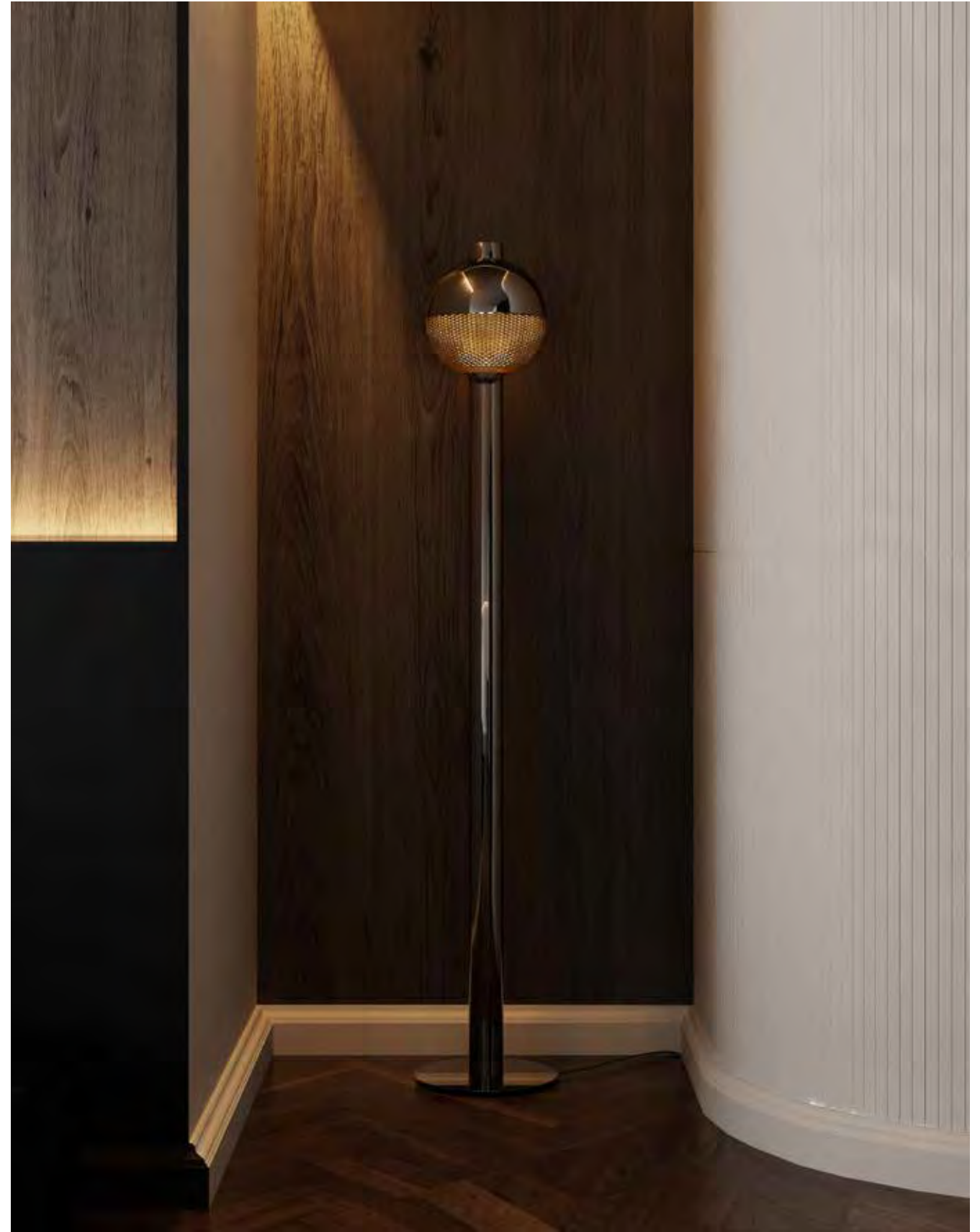

# MYA POP

DESIGNED BY LENZIA MONDIN



# MYA POP

Lampada a sospensione con struttura metallica e diffusori multipli in vetro. La grande articolazione del telaio compone una geometria complessa e radicale, sulla quale si innestano i corpi illuminanti in vetro decorato. Chiaro rimando alle sfarzose strutture architettoniche d'epoca Art Deco, il lampadario allude facilmente anche a stilemi precolombiani, rimarcati dalle evidenti spigolosità delle strutture metalliche.

*Suspension lamp with metal structure and multiple glass diffusers. With its complex and radical geometric design, the pendant lamp Mya makes for a sublime addition to contemporary decors (with a retro twist). Inspired by Art Deco, it also alludes to pre-Columbian stylistic elements as the sharp-edged metal structure underlines.*



# TILTIT

DESIGNED BY GIORGIO BISCARO



# TILTIT

Piccola e preziosa lampada da tavolo disegnata da Giorgio Biscaro, gioca sull'apparente instabilità di due sfere in vetro, in costante equilibrio sulla struttura metallica che le connette e che permette all'utilizzatore di poter rivolgere alternativamente uno dei due globi verso l'alto o il basso per modulare delicatamente l'emissione luminosa.

*This small and precious table lamp designed by Giorgio Biscaro plays on the apparent instability of two glass spheres, in constant balance on the metal structure that connects them and which allows one of the two globes to be alternately turned up or down to delicately modulate the light output.*





# LOOP

DESIGNED BY MM LAMPADARI WORKSHOP



# LOOP

La contrapposizione tra la densa trasparenza del vetro soffiato e l'opaca solidità della lama metallica che lo schermo è la caratteristica più evidente di questa lampada a montaggio su superficie, capace di illuminare delicatamente ma con adeguatezza lo spazio che la circonda.

*The contrast between the dense transparency of the blown glass and the opaque solidity of the metal blade that shields it is the most evident feature of this surface-mounted lamp, capable of delicately but adequately illuminating the space that surrounds it.*



# ARCH

DESIGNED BY MATTEO VALENTI



# ARCH

Una serie dalle linee essenziali, pulite e slanciate. Un'eleganza anni 70 che si esprime nei dettagli: snelli tubi metallici leggermente ricurvi e sfere in vetro bianco opalino. Da semplici elementi singoli arrivano ad intrecciarsi per creare volumi in perfetto equilibrio. Per la sua conformazione si presta inoltre, per progetti speciali, ad una notevole personalizzazione.

*A series with essential, clean and slender lines. A 70's elegance that is expressed in the details: slender slightly curved metal tubes and spheres in white opaline glass. From simple single elements, they can be intertwined to create perfectly balanced volumes. Due to its shape, it is also suitable, for special projects, for a considerable customization.*













# CLESSIDRA

DESIGNED BY MATTEO ZORZENONI



# CLESSIDRA

Clessidra è un progetto di lampade modulari caratterizzate da forme pure e eleganti: una ciotola rivolta verso l'alto e una verso il basso connesse da un semplice tubo, entrambi illuminanti, permettono una perfetta illuminazione. Possono essere utilizzate singolarmente oppure con struttura a ragno che permette di creare un'infinita varietà di composizioni. Struttura in metallo, illuminazione led.

*Clessidra is a project of modular lamps characterised by pure and elegant shapes: a bowl facing upwards and one downwards connected by a simple tube, both illuminating, allow perfect lighting. They can be used individually or with a spider structure that allows you to create an infinite variety of compositions. Metal structure led lighting.*







# CODE

DESIGNED BY MM LAMPADARI WORKSHOP



# CODE

Un assieme di semplici elementi dà vita a questa lampada. Due linee luminose per illuminare l'ambiente in maniera bidirezionale e che possono essere accese in maniera indipendente. Cover facili da montare e colori di impatto che lasciano il segno. Viene proposta nelle finiture grezze dell'ottone acidato e ferro decapato oppure con il rivestimento in pelle nera per un effetto più elegante.

*A combination of simple elements gives life to this lamp. Two light lines to illuminate the room bidirectionally and which can be switched on independently. Easy-to-fit covers and striking colours that leave their mark. It is available in the raw finishes of acid-etched brass and pickled iron or with black leather upholstery for a more elegant effect.*

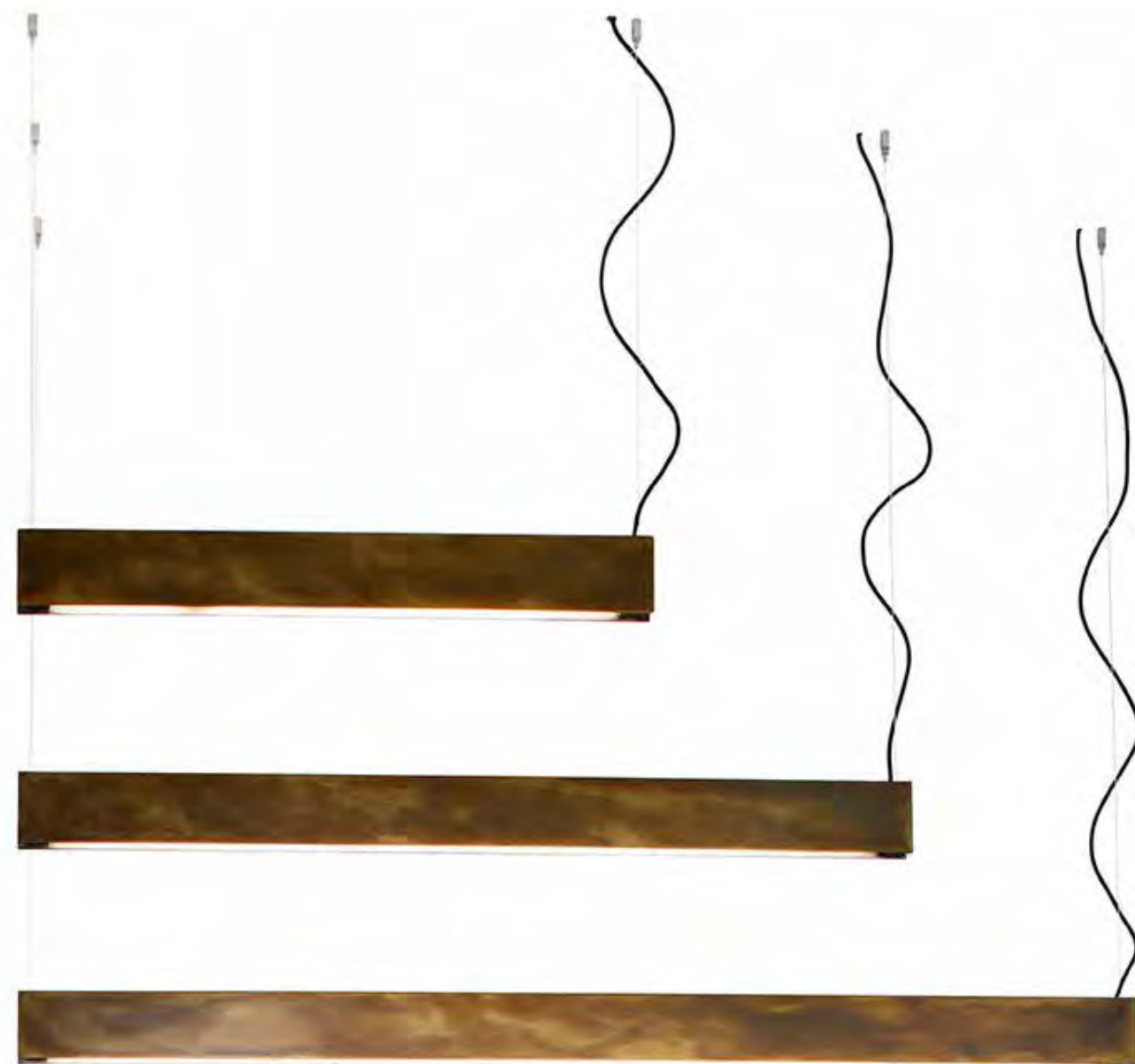



# DOTS

DESIGNED BY MATTEO ZORZENONI





# DOTS

Dots è la nuova reinterpretazione di un prodotto Classico di Maison MM, sottoposto ad una ricerca di semplicità tesa ad eliminare ogni elemento non necessario. Ciò che ne rimane è "l'anima" della struttura in metallo di cui sono stati fatti risaltare gli snodi di contatto. A sottolinearne le linee arrotondate e delle sfere in vetro bianco opalino.

*Dots is the new reinterpretation of a Classic product by Maison MM, subjected to a search for simplicity aimed at eliminating any unnecessary element. What remains is the "soul" of the metal structure of which the contact joints have been highlighted. To underline the rounded lines and spheres in white opal glass.*







# ARIA

DESIGNED BY ROBERTO FAVARETTO



COFFEE	2.5
ESPRESSO	2.5
MACCHIATO	3
CAPPUCCINO	3.5
LATTE	4
MOCHA	5
HAND POURED COFFEE	A.Q.
TEA	A.Q.
CHAI	4
COLDBREW BOTTLE	4

# ARIA

Da sempre il confronto con il concetto di vuoto, ambiguo da rappresentare, è frutto di un continuo dibattito, proprio per il senso della sua esistenza e le leggi che lo governano.

Aria con le sue linee essenziali ne scolpisce le forme incorniciandolo e puntando ad esaltarlo. Ecco quindi che il metallo dai colori naturali ed un plafone luminoso materializzano l'assenza rendendola viva e teatrale nella composizione delle forme.

*The confrontation with the concept of emptiness, which is ambiguous to represent, has always been the result of continuous debate, precisely because of the meaning of its existence and the laws that govern it.*

*Aria with its essential lines sculpts its shapes by framing it and aiming to enhance it. This is why the metal with its natural colors and a luminous ceiling materialize the absence, making it alive and theatrical in the composition of the forms.*





# PAPILLON

DESIGNED BY MATTEO ZORZENONI



# PAPILLON

Le forme fluide dei tubi metallici lavorati ad arte di questo "chandelier" vogliono ricordare il papillon, accessorio dell'abbigliamento classico. Come il simbolo di eleganza ed icona di stile sin dalla fine del XIX secolo queste lampade arredano e completano l'immagine dell'ambiente in cui sono inserite donandole un tocco di ricercatezza.

*The fluid shapes of the metal tubes worked to art of this "chandelier"; want to remember the bow tie, accessory of the classic clothing. As the symbol of elegance and style icon since the end of the 19th century, these lamps furnish and complete the image of the environment in which they are placed, giving it a touch of sophistication.*









# MOONLIGHT

DESIGNED BY MATTEO ZORZENONI



# MOONLIGHT

Moonlight è una collezione di lampade dalla forte connotazione grafica. Scegliendo fra tre disegni diversi di lamiere metalliche sagomate ed applicabili tramite dei magneti alla struttura è possibile customizzare in maniera differente ogni lampada. Viene fornita con sistema di illuminazione integrato, disponibile in due dimensioni e nelle finiture nero opaco e ottone satinato.

*Moonlight is a collection of lamps with a strong graphic connotation. Choosing between three different designs of shaped metal sheets and applicable by means of magnets to the structure you can customize each lamp in a different way. Comes with integrated lighting system, available in two sizes and in matt black and satin brass finishes.*









# BELLA TUBE

DESIGNED BY MM LAMPADARI WORKSHOP





# BELLA TUBE

Un piccola sfera di vetro di Murano dalle molte sfaccettature è l'elemento decorativo di questa sospensione che ricorda la cristalleria più preziosa e conferisce alla luce circostante giochi di riflessi eleganti, mantenendo nel piano sottostante una luce funzionale e puntuale.

*A small sphere of Murano glass with many facets is the decorative element of this pendant that recalls the most precious glassware and gives the surrounding light a play of elegant reflections, keeping in the floor below a functional and punctual light.*





# RIPPLE

DESIGNED BY MM LAMPADARI WORKSHOP



# RIPPLE

Le sinuose onde concentriche del vetro di Murano, ricordano il movimento superficiale dell'acqua distribuendo uniformemente la luce. Un disco di metallo ne incornicia le forme evidenziandole e dirige la luce sul piano sottostante.

*The sinuous concentric waves of Murano glass recall the surface movement of water, uniformly distributing the light. A metal disc frames the shapes, highlighting them and directing the light onto the surface below.*





# BALLOON

DESIGNED BY MATTEO ZORZENONI



# BALLOON

Balloon prende spunto da un prodotto già presente nel catalogo classico.

Rivisto e ripulito di qualsiasi fronzolo viene presentato in chiave contemporanea, mettendone in risalto la struttura. Presentato nelle finiture nero opaco ed oro zecchino, la base in ceramica accompagna con grazia il paralume in tessuto che nei dettagli ne segue il colore principale. Una elegante luce diffusa ed eterea completa l'eleganza con cui la lampada si presenta già al primo sguardo.

*Balloon takes its cue from a product already present in the classic catalog.*

*Revised and cleaned of any frills, it is presented in a contemporary key, highlighting its structure. Presented in matt black and pure gold finishes, the ceramic base gracefully accompanies the fabric lampshade, which in the details follows the main colour. An elegant diffused and ethereal light completes the elegance with which the lamp appears at first glance.*







# BALLOTON

DESIGNED BY MATTEO ZORZENONI



# BALLOTON

Balloton riporta alla luce la tecnica veneziana del soffiaggio del vetro e la reinterpreta in questa suggestiva collezione di lampade in metallo. Moduli disponibili singolarmente o in grandi composizioni a "chandelier", disponibili ora anche nella versione mini che è adattabile a plafoni già in uso per altre gamme di prodotto.

*Balloton brings to light the Venetian technique of glass blowing and reinterprets it in this evocative collection of metal lamps. Modules available individually or in large "chandelier" compositions, now also available in the mini version that can be adapted to ceilings already in use for other product ranges.*







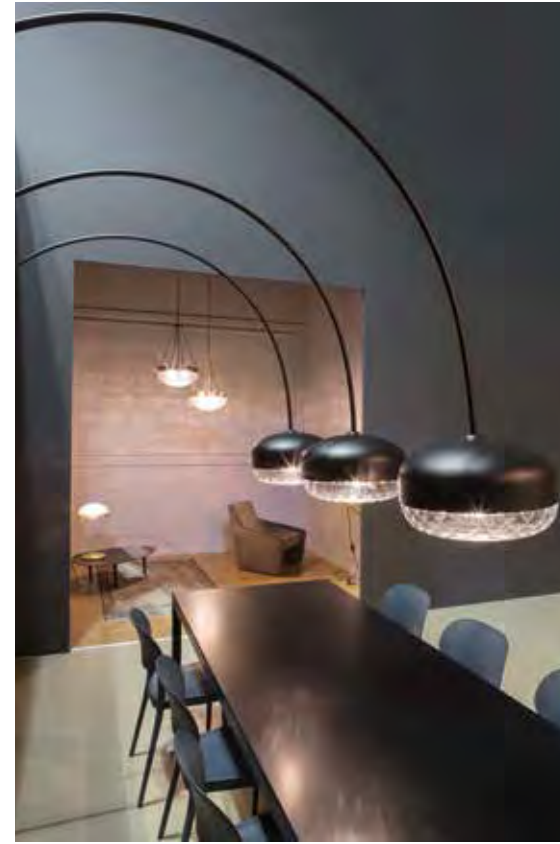

# CHILL

DESIGNED BY MASSIMO ZAZZERONI



# CHILL

Chill evoca le linee fluide e semplici dell'arte e del design, dove la grafica si fonde alla semplicità delle forme.

Le strutture in metallo verniciato opaco sostengono sfere metalliche con illuminazione a led direzionabili e boule di vetro soffiato muranese che permettono differenti modalità di illuminazione, diffusa e puntuale.

*Chill evokes the fluid and simple lines of art and design, where graphics blend with the simplicity of forms.*

*The structures in opaque painted metal, support metal spheres with directional Led lighting and Murano blown glass boule that allow different modes of lighting, diffused and punctual.*









# LAYLA

DESIGNED BY SERENA CONFALONIERI



# LAYLA

Il profilo riprende la forma delle vecchie lampade ad olio e dei vecchi lumini da notte, oggetti caldi e rassicuranti che conferiscono alla stanza un'atmosfera intima, richiamando un immaginario domestico. Il nome Layla, infatti, deriva dal vocabolo arabo ليلى (laylah) che vuol dire "notte", e suggerisce un utilizzo della lampada negli ambienti più intimi, accompagnando fino al momento del sonno.

*Its shape reminds the old oil lamps and nightstand lights, warm and reassuring objects that give the room an intimate atmosphere, recalling a domestic imaginary. The name Layla derives from the Arabic word ليلى (laylah) which means "night" and suggests a use of the lamp in the most intimate spaces: it keeps us company until the moment of sleep.*



# LEAF

DESIGNED BY MATTEO ZORZENONI



# LEAF

Ispirata alla natura e all'armonia degli spazi, Leaf propone una struttura metallica leggera ed eclettica in metallo, con diffusore in vetro frutto di un'accurata ricerca progettuale.

Avulsa da qualsiasi stile, le sue forme pulite che ne esaltano la silhouette nello spirito del minimalismo, si integra perfettamente in qualsiasi ambiente evidenziandone il carattere.

*Inspired by nature and the harmony of space, Leaf proposes a light and eclectic metal structure, with glass diffuser, the result of careful design research. It is free from any style, its clean shapes that enhance the silhouette in the spirit of minimalism, it integrates perfectly into any environment highlighting its character.*



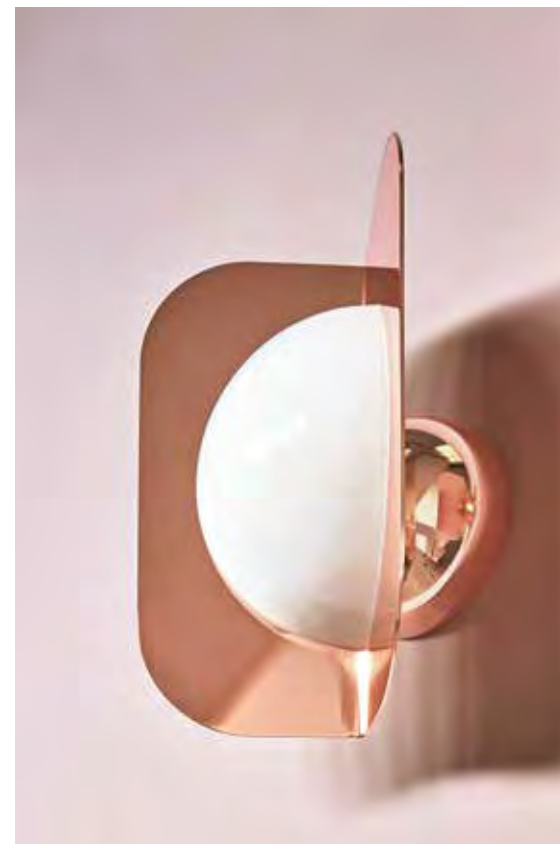

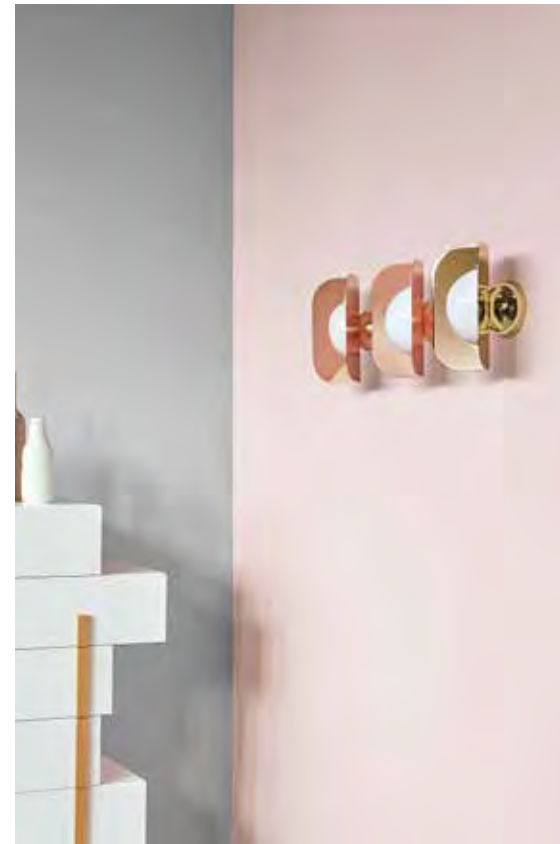

# MAESTRO

DESIGNED BY MM LAMPADARI WORKSHOP





# MAESTRO

L'intramontabile forma sferica reinterpretata con una compatta superficie ondata che esalta la diffusione della luce. La famiglia comprende lampada a sospensione in due misure, lampada da tavolo e lampada da terra. Diffusore in vetro di Murano bianco latte sfumato e struttura in metallo verniciato.

*The timeless spherical shape reinterpreted with a compact wave surface that enhances the dissemination of Light. The family includes pendant lamp in two sizes, table lamp and floor lamp. Diffuser in Murano white shaded milk glass and painted metal structure.*





# MATA

DESIGNED BY SERENA CONFALONIERI



# MATA

La nuova collezione di lampade a parete disegnata da Serena Confalonieri è un omaggio a Mata Hari, la spia danzatrice dell'inizio del secolo scorso che ammaliava i potenti e ne carpiva i segreti, spogliandosi lentamente dei suoi veli fino a rimanere vestita solo dei suoi gioielli. Sono proprio i gioielli decò indossati dalla spia l'ispirazione per questa collezione di appliques, pensata per impreziosire le pareti grazie ad un mix di forme geometriche e materiali con una sovrapposizione di vetro colato in lastra opalescente e volumi in elegante marmo. Gli elementi in vetro e quelli in marmo possono essere accostati con grande libertà, aprendo la strada ad un'ampia gamma di modelli e abbinamenti cromatici.

*The new collection of wall lamps designed by Serena Confalonieri is a tribute to Mata Hari, the dancing spy of the beginning of the last century who enchanted the powerful and grasped their secrets, slowly stripping off her veils until she was dressed only in her jewels. It is precisely the deco jewelry worn by the spy that inspires this collection of appliques, designed to embellish walls thanks to a mix of geometric shapes and materials with an overlapping of cast glass in opalescent slab and volumes in elegant marble. Glass and marble elements can be combined with great freedom, paving the way for a wide range of models and chromatic combinations.*





# MILA

DESIGNED BY CHIARA ANDREATTI STUDIO SALARIS

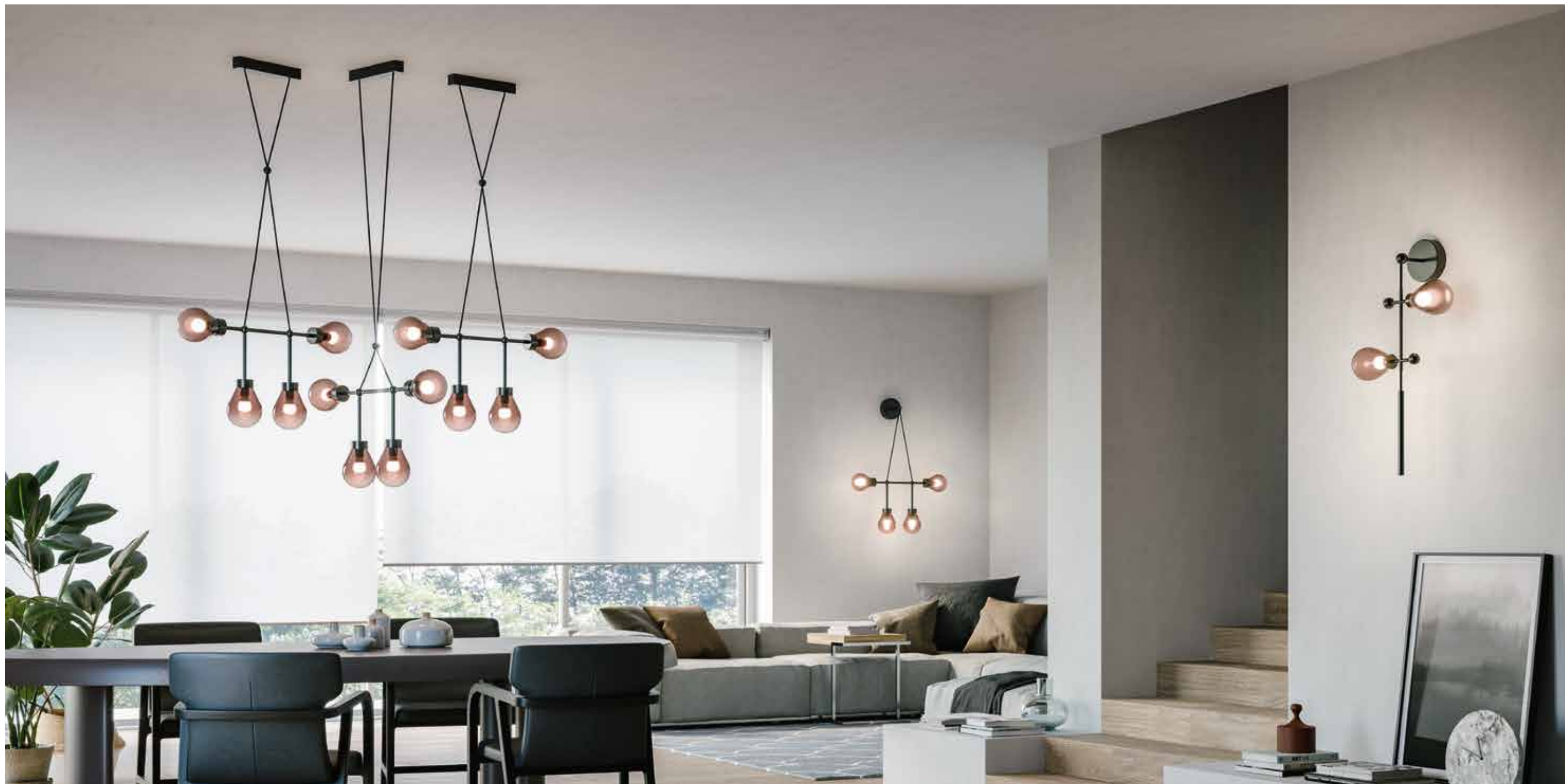

# MILA

Ispirata alle gloriose lampade dell'Art Decò ne adotta gli stilemi con una rilettura dal sapore contemporaneo. Elemento cardine del progetto è il cavo elettrico, parte essenziale del linguaggio estetico del progetto. Un elemento regolabile che consente di variarne le linee grafiche e l'aspetto formale. Struttura in metallo verniciato colore carbon black, globi in vetro fumè rosato.

*Inspired by the glorious lamps of Art Deco, it adopts their stylistic features with a contemporary reinterpretation. The key element of the project is the electric cable, an essential part of the aesthetic language of the project. An adjustable element that allows to vary the graphic lines and the formal appearance. Structure in carbon black painted metal, globes in smoked pink glass.*







# PINEAPPLE

DESIGNED BY MATTEO ZORZENONI



# PINEAPPLE

Il restyling della tradizione artigiana ha dato vita ad una collezione originale e affascinante, dove il vetro lucido di Murano soffiato su stampo del paralume si sposa finemente con la base in ceramica in texture materica romboidale. Disponibile in vari abbinamenti cromatici che lo rendono un elemento decorativo molto pop.

*The restyling of the artisan tradition has given life to an original and fascinating collection, where the shiny Murano glass blown on the mould of the lampshade blends finely with the ceramic base in rhomboidal material texture. Available in various color combinations that make it a very pop decorative element.*





# RAIN

DESIGNED BY CENTRO STILE MM LAMPADARI



# RAIN

Le suggestioni che la pioggia suscita cambia anche la visione del mondo che ci circonda cadendo dal cielo e rendendo suggestivo ogni luogo.

E proprio come la pioggia che scende leggera e diligente anche gli elementi di queste lampade ridisegnano l'ambiente con costanti intrecci di fili obliqui a formare una trama di bulbi in vetro specchiato lucenti.

*The suggestions that the rain provokes also change the vision of the world that surrounds us, falling from the sky and making every place evocative.*

*Just like the rain that falls lightly and diligently, the elements of these lamps redesign the environment with constant interlacing of oblique threads to form a weave of shiny mirrored glass bulbs.*











# WHALE

DESIGNED BY LEO DE CARLO MIST

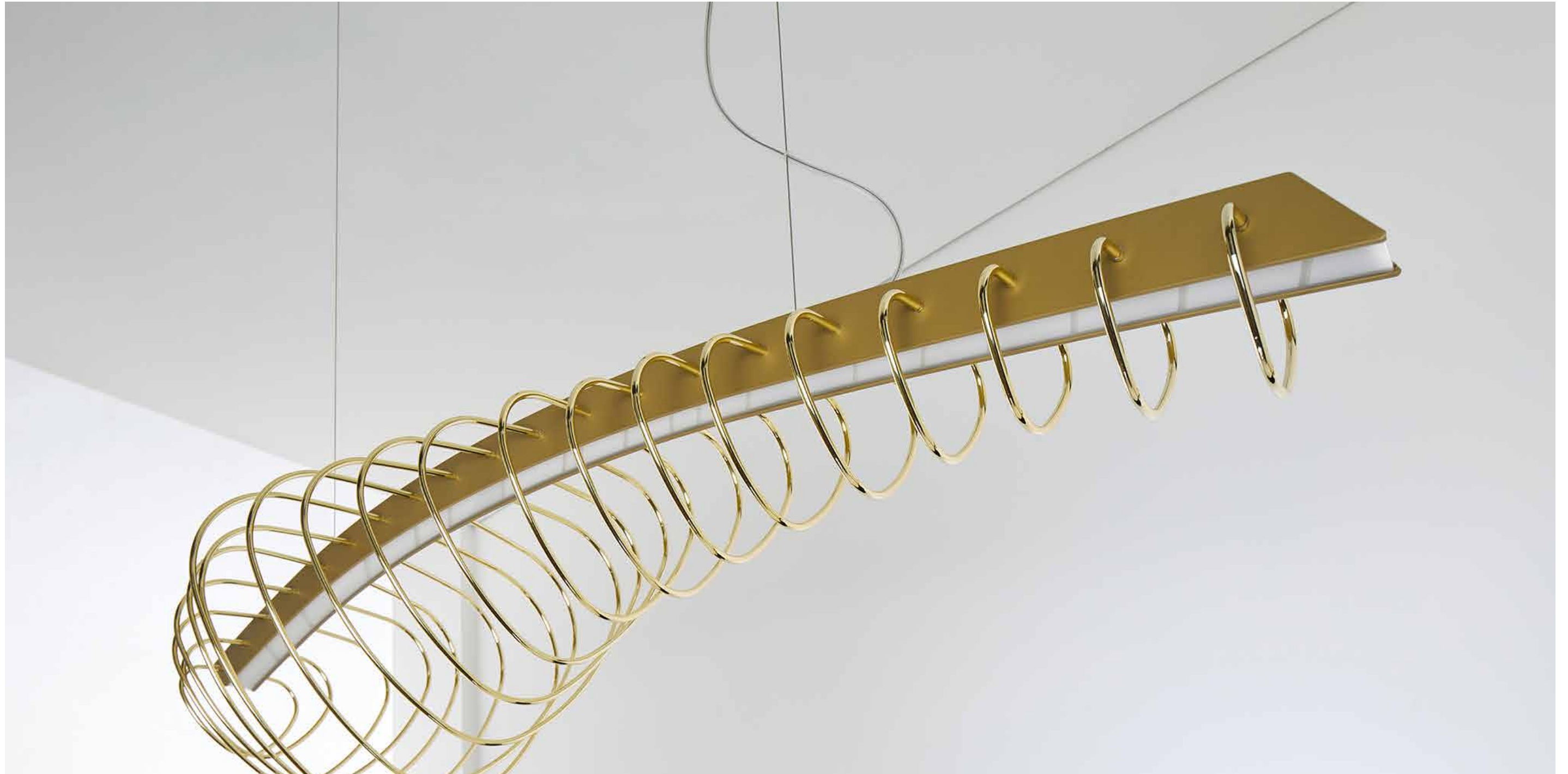

# WHALE

Whale rappresenta il gesto di trasformare un simbolo della potenza naturale come una balena in qualcosa di rassicurante e utile: il tentativo di addomesticare la forma naturale attraverso la tecnica per ricordarci che comunque, nella profondità dei nostri cuori, è la natura l'elemento che ci sovrasta, ci ispira e ci guida.

*Whale represents the gesture of transforming a symbol of natural power as a whale into something reassuring and useful: anyway, the attempt to domesticate the natural form through the technique to remind us that, in the depths of our hearts, is nature the element that dominates us, inspires us and guides us.*



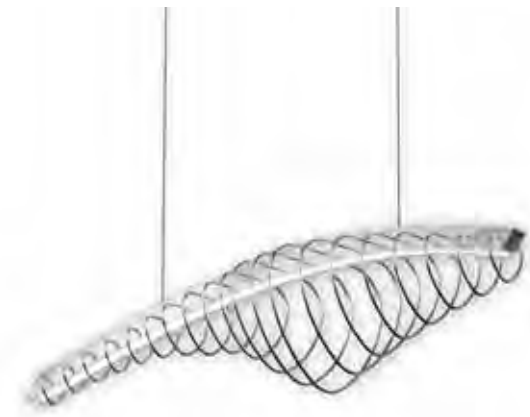

# KINGDOM

DESIGNED BY LEO DE CARLO MIST



# KINGDOM

Nel medioevo e nel rinascimento, l'illuminazione delle abitazioni era ottenuta mediante candelabri e lampade ad olio organizzate in maniera cadenzata su anelli in ferro o legno. Kingdom è la reinterpretazione di questo archetipo di lampada, adattato al gusto contemporaneo: un semplice anello tubolare da cui spuntano, in maniera ripetuta e ordinata, delle "candele tecnologiche" arricchite da un elemento decorativo in vetro lavorato.

*In the Middle Ages and the Renaissance, the lighting of dwellings was obtained using candelabra and oil lamps arranged in a cadence on iron or wood rings. Kingdom is the reinterpretation of this lamp archetype, adapted to the contemporary taste: a simple tubular ring from which emerge, in a repeated and orderly manner, of "technological candles" enriched by a decorative element in worked glass.*







# PARAMOUNT

DESIGNED BY ROBERTO FAVARETTO





# PARAMOUNT

Una linea unica e vigorosa controfirma le forme di Paramount, che allontana deliberatamente la ricerca della varietà decorativa dando varie possibilità teoriche di combinazioni allo stesso tempo.

La scelta di utilizzare meno materiale possibile rispecchia, infatti, l'idea che ciò che immediatamente è comprensibile, è immediato e più ragionevole. Essenziale.

*A unique and vigorous line countersigns the forms of Paramount that deliberately runs away the search of the decorative variety giving various theoretical possibilities of combinations at the same time. The choice to use less material possible it mirrors, in fact, the idea that what immediately is comprehensible, is immediate and more reasonable. Essential.*







**ARCH**

Lampada in metallo verniciato e vetro borosilicato  
Painted metal lamp and borosilicate glass

**Struttura / Frame**

V2828  
Canna di fucile  
Gunmetal grey

V2832  
Canna di fucile  
con particolari  
ottone lucido  
Gunmetal grey  
with glossy  
brass details

V0216  
Ottone lucido  
Glossy brass

**Diffusore / Diffuser**

Bianco lucido  
Glossy white

**Su richiesta / On request**

Ambra  
Amber

Fumè  
Fumè

**Illuminazione / light source**

5W G9 220V/240V

Lampadina non compresa / Bulb not included.



**MMM**

**ARIA**

Lampada in metallo, verniciato o trattamento galvanico, con diffusore in PMMA  
Metal lamp, painted or galvanic treatment, with PMMA diffuser

**Struttura / Frame**

V2907  
Bianco Opaco  
Matt white

V0199  
Nero opaco  
Matt black

V2902  
Ottone ossidato  
Burnished Brass

**Diffusore / Diffuser**

Bianco opale  
Ice white

**Illuminazione / light source**



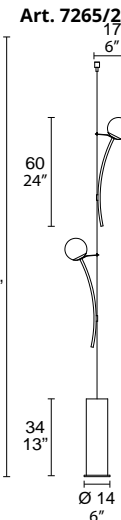
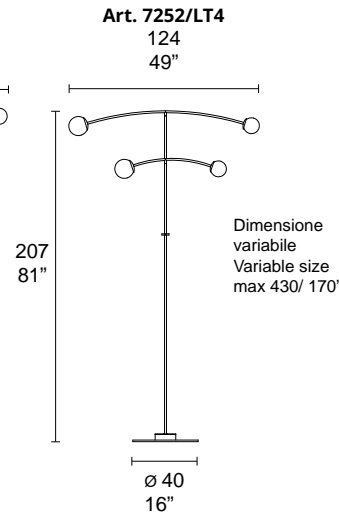
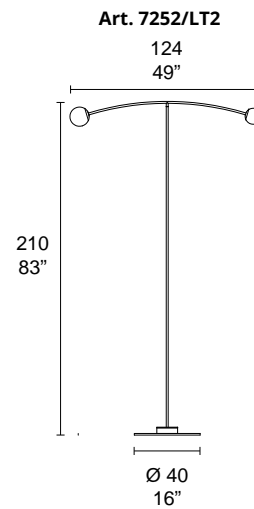
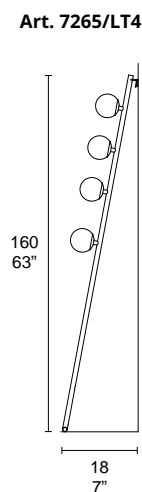
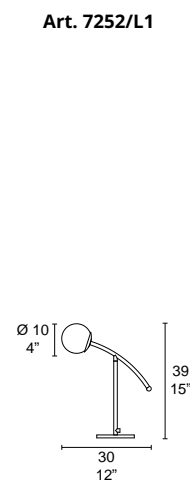
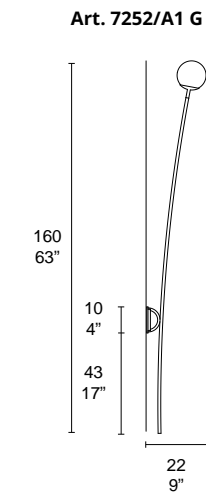
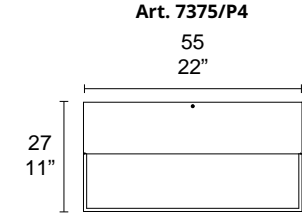
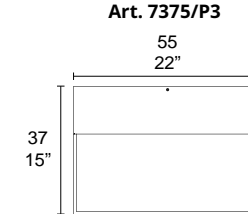
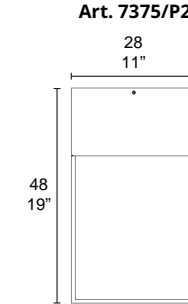
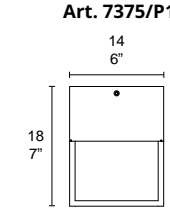
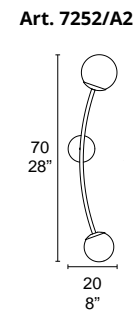
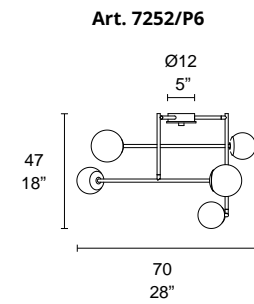
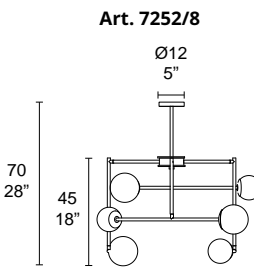
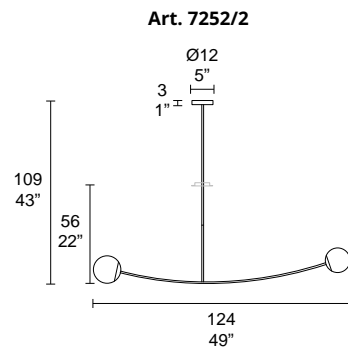
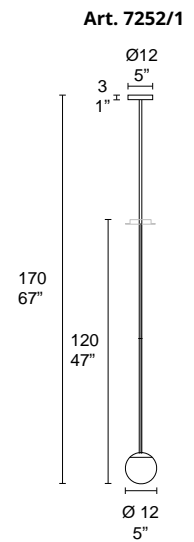
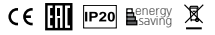

LED  
12 / 20 / 24 W  
3000 K



Dimensione  
variabile  
Variable size  
max 430/ 170"

**BALLOON**

Lampada in ceramica con paralume in tessuto  
Ceramic lamp with fabric shade

Struttura / Frame	Diffusore / Diffuser	illuminazione / light source
<ul style="list-style-type: none"> <li> V0199 Nero opaco Matt black</li> <li> V0197 Oro 24K Gold 24K</li> </ul>	<ul style="list-style-type: none"> <li> Paralume in tessuto bianco / elementi Oro White fabric shade / Gold elements</li> <li> Paralume in tessuto bianco / elementi neri White fabric shade / black elements</li> </ul>	<ul style="list-style-type: none"> <li> 1 x max 11W shape T37 max Ø37mm</li> </ul>



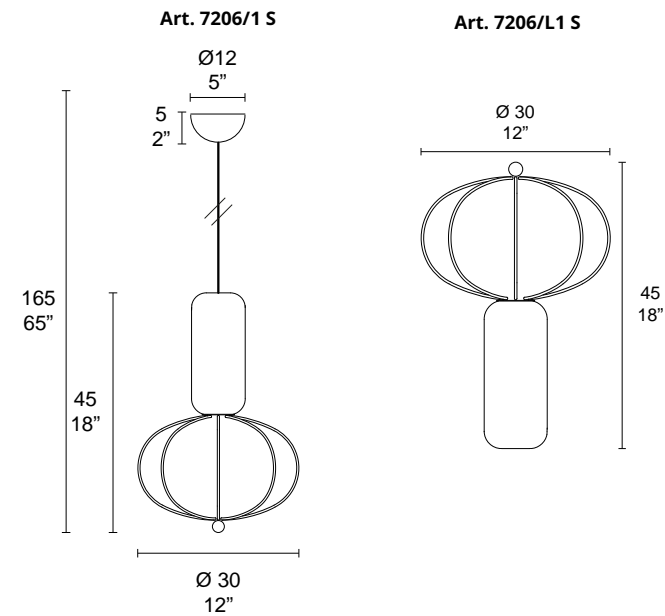





Lampadina non compresa / Bulb not included.



**MMM**

**BALLOTON**

Lampada in metallo, verniciato o trattamento galvanico, e vetro murano balloton  
Metal lamp, painted or galvanic treatment, and murano balloton glass

Struttura / Frame	Diffusore / Diffuser	illuminazione / light source
<ul style="list-style-type: none"> <li> V0199 Nero opaco Matt black</li> <li> V2907 Bianco Opaco Matt White</li> <li> V2806 Rame lucido Glossy copper</li> </ul>	<ul style="list-style-type: none"> <li> Balloton trasparente Crystal Balloton</li> <li> Balloton Fumé Smoked balloton</li> <li> Vetro bianco sfumato White shaded glass</li> </ul>	<ul style="list-style-type: none"> <li> 20W E27</li> <li> 10W E14</li> <li> 5W G9</li> </ul>

Lampadina non compresa / Bulb not included.

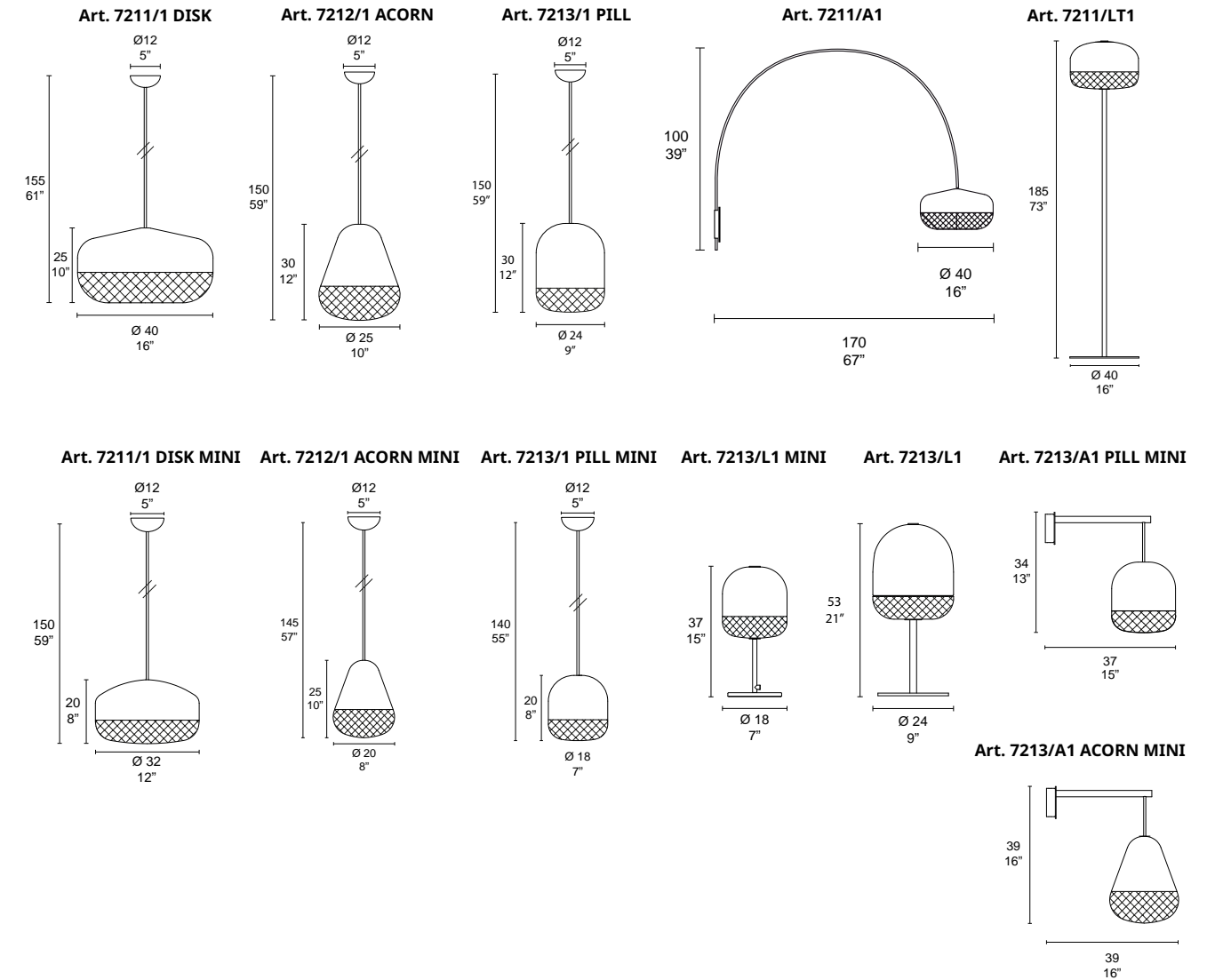
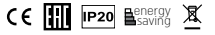

## BELLA TUBE

Lampada in metallo verniciato e vetro murano soffiato  
Painted metal and murano blown glass lamp



### Struttura / Frame

● V0199  
Nero opaco  
Matt black

### Diffusore / Diffuser

● Fumè  
Fumè

### Illuminazione / light source

  
5W G9 LED 220V/240V  

Lampadina non compresa / Bulb not included.



Art. 7395/1

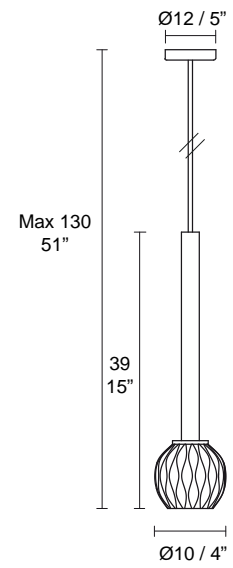

Art. 7395/1

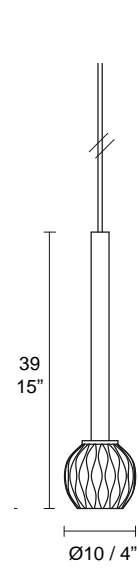

## MMM

## CHILL

Lampada in metallo verniciato, diffusori in vetro murano soffiato e diffusori direzionabili PMMA  
Painted metal lamp, Murano blown glass and directional PMMA diffusers

### Struttura / Frame



● V0199  
Nero opaco  
Matt black

○ V2907  
Bianco opaco  
Matt white

### Diffusore / Diffuser

● Fumè satinato  
Satin fumè  
+  
○ PMMA opale  
Ice white

### Lampadina / Bulb

  
20W E27  
non include  
not included  

LED BOARD 4,5W  
3000 K  
include  
included  

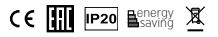

Art. 7330/6

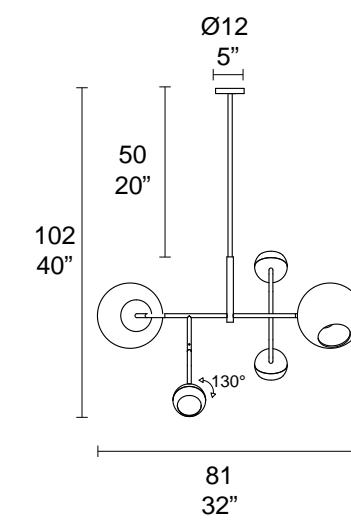

Art. 7330/A2

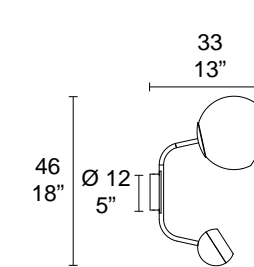

**CHOOPS**

Lampada in metallo verniciato e vetro soffiato  
Painted metal and blown glass lamp

Struttura / Frame      Diffusore / Diffuser      Illuminazione / light source

Art. 7431/1      Art. 7431/LT1      Art. 7431/L1

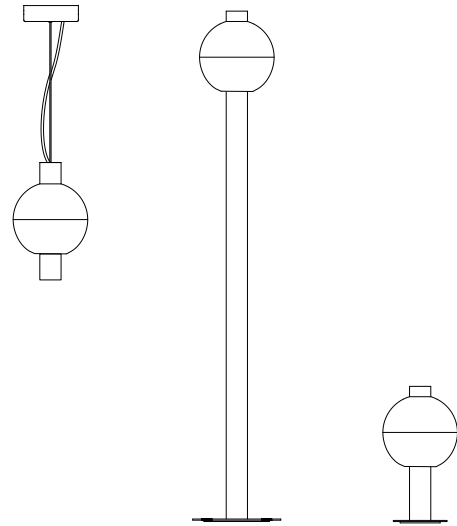

**MMM**



**CLESSIDRA**

Lampada in metallo verniciato dettagli galvanici e diffusore PMMA  
Painted metal lamp galvanic details, PMMA diffuser

Struttura / Frame      Diffusore / Diffuser      Illuminazione / light source

○ V2852  
Bianco opaco con particolari in ottone lucido  
Matt white with glossy brass details

● V2853  
Nero opaco con particolari in ottone lucido  
Matt black with glossy brass details

○ Bianco opale  
Ice white

5W G9

Lampadina non compresa / Bulb not included.

Su richiesta / On request

LED BOARD 4,5W  
3000°K

LED BOARD 8W  
3000°K

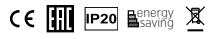

Art. 7331/2 (1 pendente/pendant)

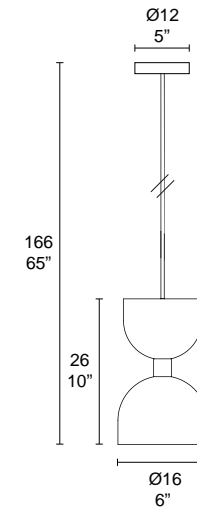

Art. 7331/8 (4 pendenti/pendants)

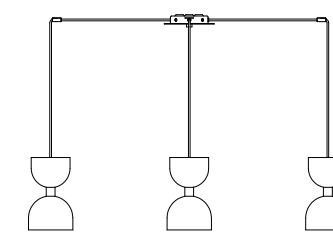

Art. 7331/16 (8 pendenti/pendants)

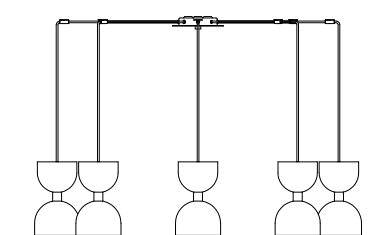

Art. 7331/48 (24 pendenti/pendants)

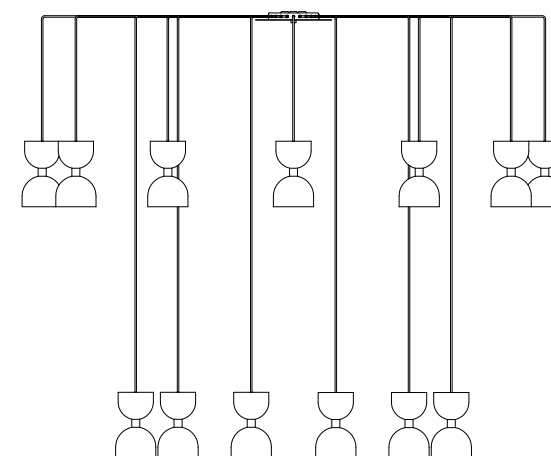

Art. 7331/A2

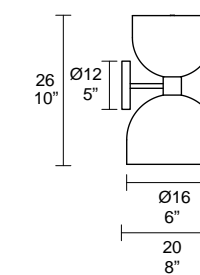

Lampada in metallo verniciato o trattamento galvanico con diffusore in PMMA  
Painted metal lamp or galvanic treatment with PMMA diffuser

Struttura / Frame      Diffusore / Diffuser      Illuminazione / light source

- V2905  
Ottone ossidato  
Burnished brass  
(struttura esterna)
- Nero opaco  
Matt black  
(struttura interna)
- V2916  
Ferro Decapato  
Pickled iron  
(struttura esterna)
- Nero opaco  
Matt black  
(struttura interna)
- V0199  
Rivestimento in pelle  
Leather  
(struttura esterna)
- Nero opaco  
Matt black  
(struttura interna)

- Bianco opale  
Ice white

STRIP LED  
25/ 35/ 45 W  
3000K



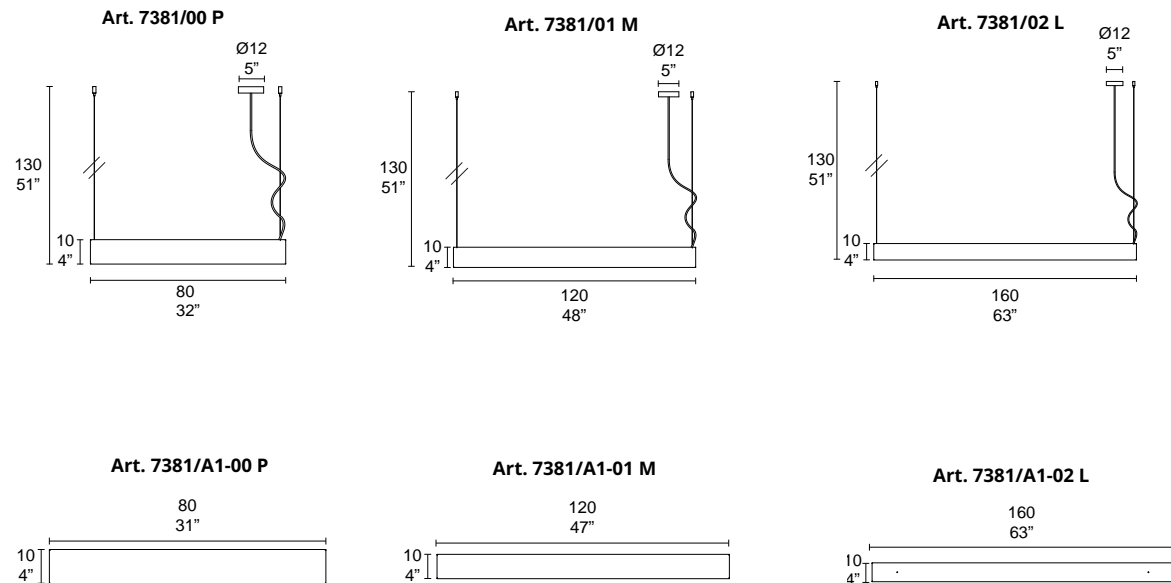

Lampada in metallo, verniciato o trattamento galvanico e vetro borosilicato  
Metal lamp, painted or galvanic treatment with and borosilicate glass

Struttura / Frame      Diffusore / Diffuser      Lampadina / Bulb

- V2821  
Nero opaco con  
dettagli foglia oro  
Matt black with  
gold leaf details
- V2809  
Bianco lucido con  
particolari in  
foglia rame  
Glossy white with  
copper leaf details
- V2824  
Ottone opaco  
Matt brass
- V2806  
Rame lucido  
Glossy copper
- V0216  
Ottone lucido  
Glossy brass

- bianco  
White

  
5W G9

Su richiesta / On request

- Ambra  
Amber
- Fumè  
Fumè

Lampadina non compresa / Bulb not included.

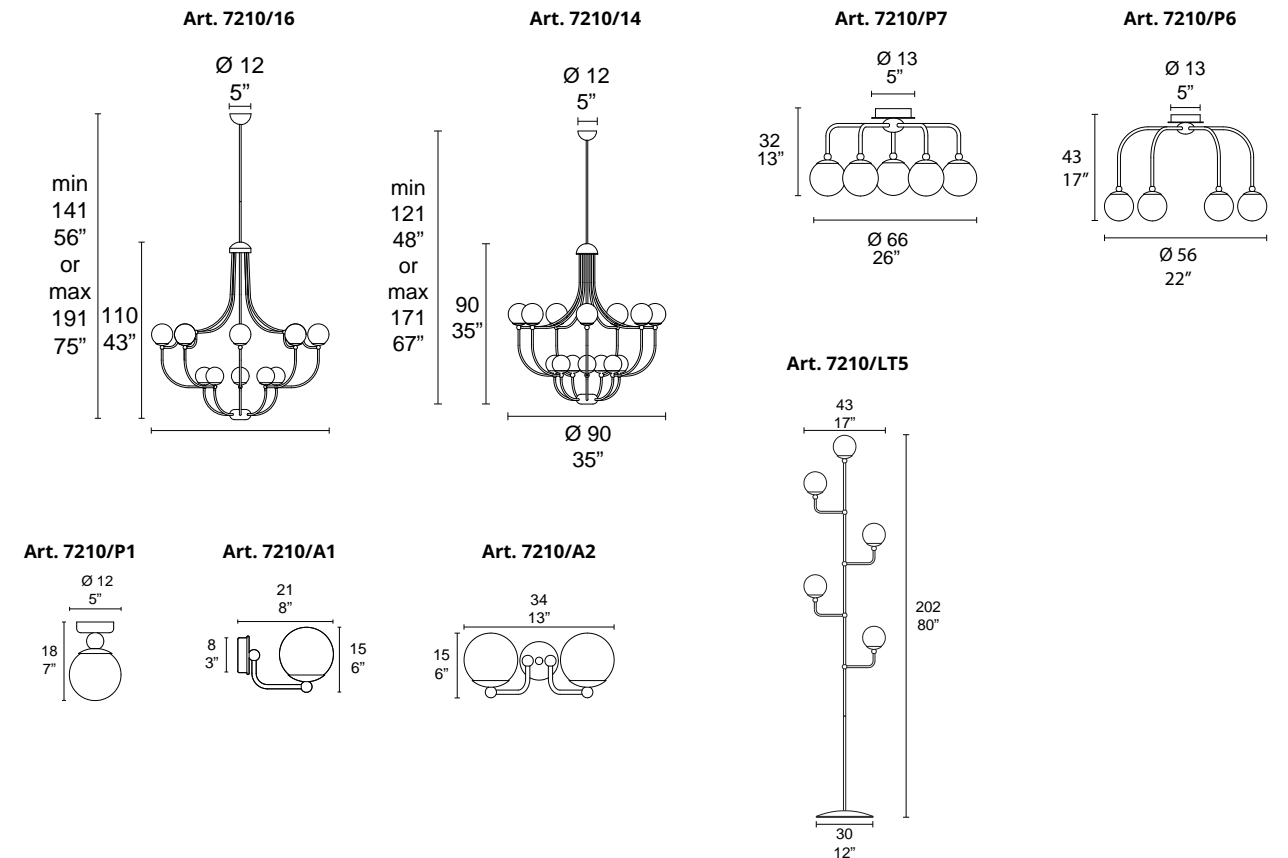
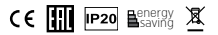



**KINGDOM**

Lampada in metallo verniciato o trattamento galvanico con diffusore vetro borosilicato  
Painted metal lamp or galvanic treatment and borosilicate glass

Struttura / Frame      Diffusore / Diffuser      Illuminazione / light source

- V2907  
Bianco Opaco RAL  
Matt White RAL
- V0266  
Brunito galvanico  
Galvanic burnished

- ▨ Rigato  
Trasparente  
Transparent

- 💡 15W E14

Lampadina non compresa / Bulb not included.

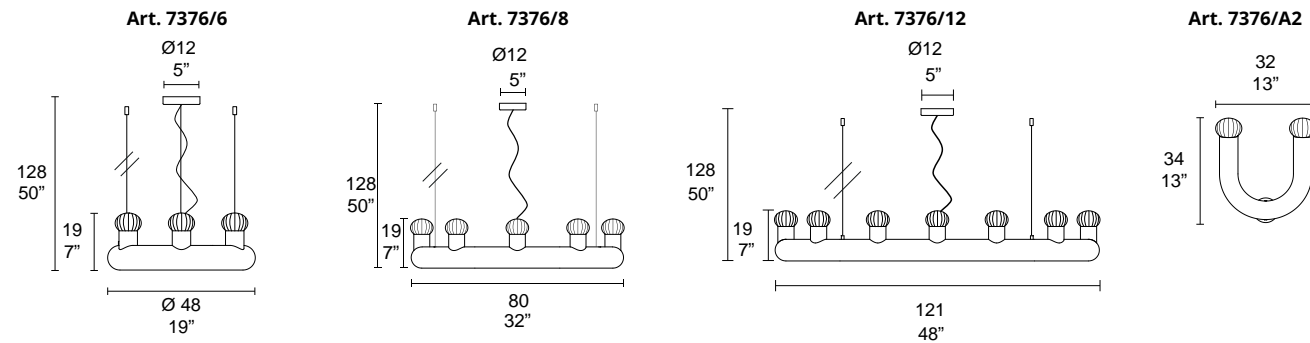

**MMM**

**LAYLA**

Lampada in metallo e vetro di Murano  
Metal and Murano glass lamp

Struttura / Frame      Diffusore / Diffuser      Illuminazione / light source

- V0199  
Nero opaco  
Matt black

- filigrana bianca + cristallo  
filigree white + crystal
- filigrana tabacco + blu  
filigree tobacco + blue
- filigrana blu + ambra  
filigree blue + amber
- filigrana rubino + smeraldo  
filigree ruby + emerald
- filigrana rosso + pesca  
filigree red + peach

110 / 240V 1 x LED BOARD 6,W 983lm 3000K  
Incluso / Included

Dimmerabile su cavo  
Dimmable on cable

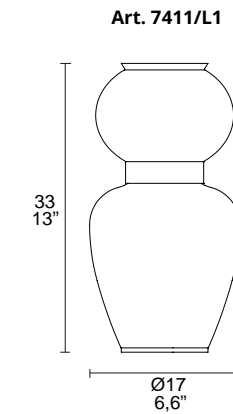
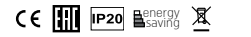

**LEAF**

Lampada in metallo verniciato o trattamento galvanico con diffusore in vetro  
Painted metal lamp or galvanic treatment with glass diffuser

- | Struttura / Frame   | Diffusore / Diffuser   | Illuminazione / light source  |
|---|--|---|
| <ul style="list-style-type: none"> <li><span style="display: inline-block; width: 10px; height: 10px; background-color: black; border-radius: 50%; margin-right: 5px;"></span> V0199<br/>Nero opaco<br/>Matt black</li> <li><span style="display: inline-block; width: 10px; height: 10px; background-color: #444; border-radius: 50%; margin-right: 5px;"></span> V2900<br/>Ferro decapato<br/>Pickled iron</li> <li><span style="display: inline-block; width: 10px; height: 10px; background-color: #d4b87d; border-radius: 50%; margin-right: 5px;"></span> V0216<br/>Ottone lucido<br/>Glossy brass</li> <li><span style="display: inline-block; width: 10px; height: 10px; background-color: #c87137; border-radius: 50%; margin-right: 5px;"></span> V2807<br/>Rame satinato<br/>Satin copper</li> <li><span style="display: inline-block; width: 10px; height: 10px; background-color: #d9c7b8; border-radius: 50%; margin-right: 5px;"></span> V2805<br/>Ottone satinato<br/>Satin brass</li> <li><span style="display: inline-block; width: 10px; height: 10px; background-color: #c87137; border-radius: 50%; margin-right: 5px;"></span> V2806<br/>Rame lucido<br/>Glossy copper</li> <li><span style="display: inline-block; width: 10px; height: 10px; background-color: #a89c5d; border-radius: 50%; margin-right: 5px;"></span> V2824<br/>Ottone opaco<br/>Matt brass</li> <li><span style="display: inline-block; width: 10px; height: 10px; background-color: #665d4d; border-radius: 50%; margin-right: 5px;"></span> V0266<br/>Brunito galvanico<br/>Burnished</li> </ul> | <ul style="list-style-type: none"> <li><span style="display: inline-block; width: 10px; height: 10px; border: 1px solid black; border-radius: 50%; margin-right: 5px;"></span> bianco<br/>White</li> </ul> | <ul style="list-style-type: none"> <li> 5W G9<br/>non include<br/>not included</li> <li> LED BOARD 4,5W<br/>220-240V<br/>3000°K<br/>include<br/>included</li> </ul> |



**MMM**

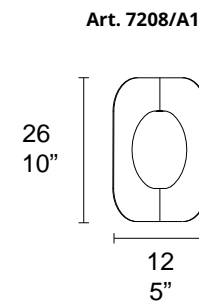
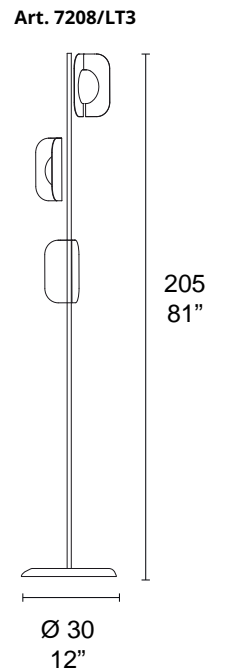
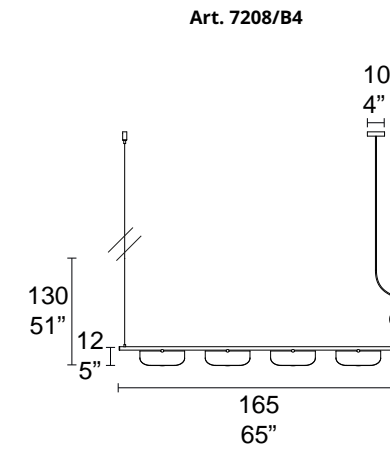
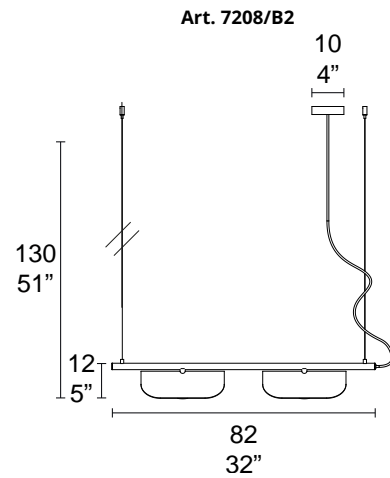
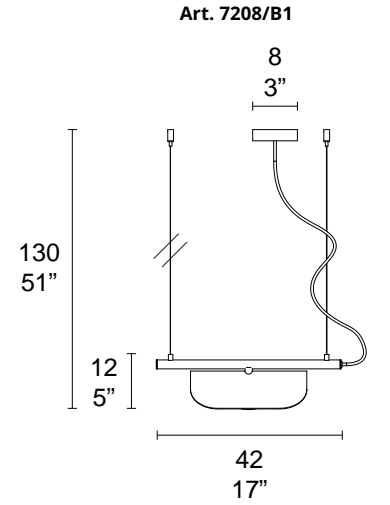
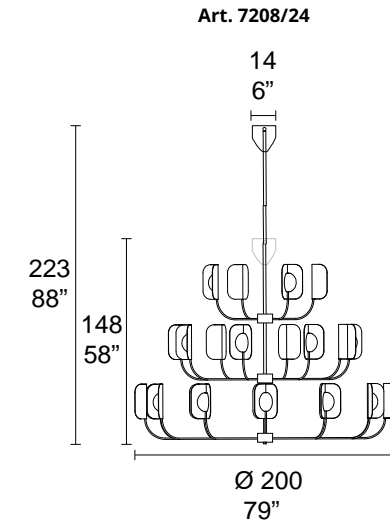
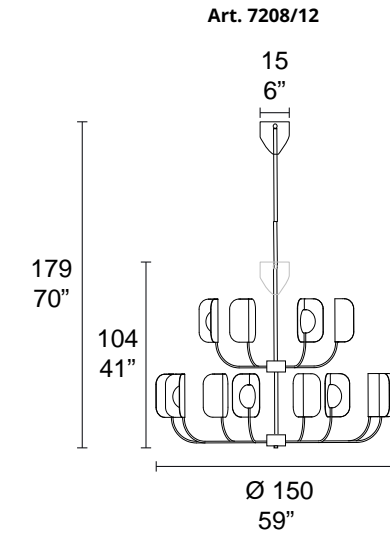
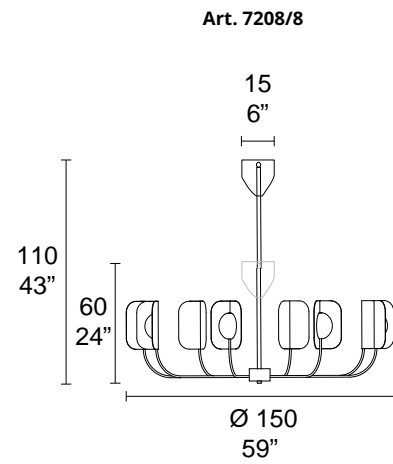
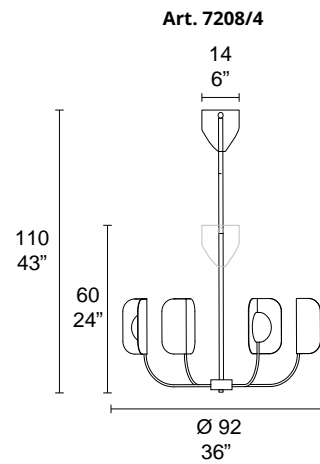
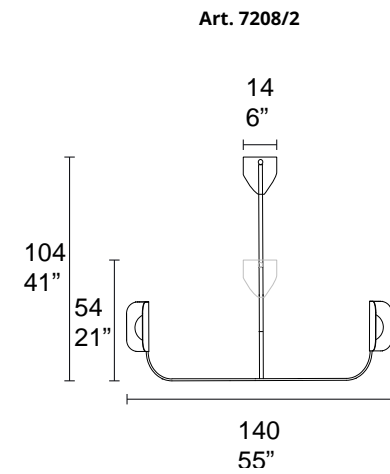

**LOOP**

Lampada in metallo con trattamento galvanico e diffusore in vetro Murano  
 Metal lamp with galvanic treatment and Murano glass diffuser

**Struttura / Frame**

V0216  
 Ottone lucido  
 Glossy brass

**Diffusore / Diffuser**

bianco latte  
 Milk White

**Illuminazione / light source**

Strip LED 7W  
 3000K 220V/240V

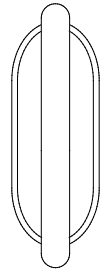
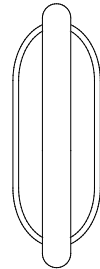
**Art. 7423/A1****Art. 7423/P1****MMM****MAESTRO**

Lampada in metallo e vetro soffiato di Murano  
 Lamp in metal and blown Murano glass

**Struttura / Frame**

V2945  
 Nickel  
 Nickel

**Diffusore / Diffuser**

Bianco sfumato cristallo  
 White Shaded crystal

**Illuminazione / light source**



 20W E27 220V/240V  
 non include  
 not included

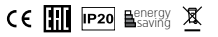
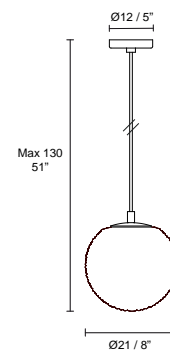
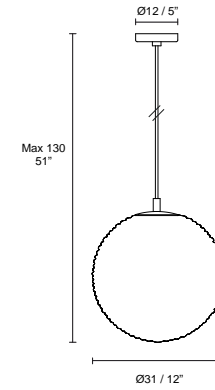
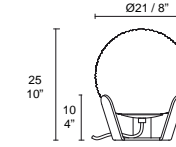
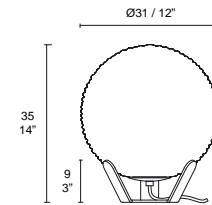
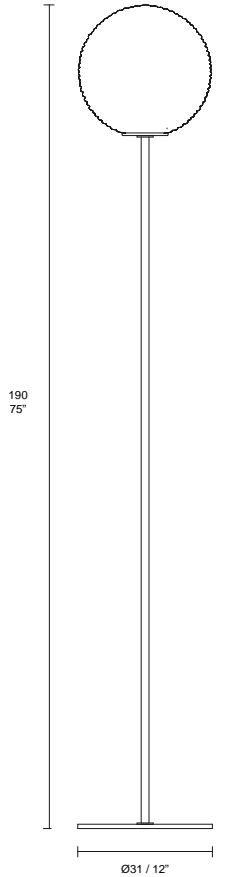



Lampadina non compresa / Bulb not included.

**Art. 7403/1 S****Art. 7403/1 L****Art. 7403/L1 S****Art. 7403/L1 L****Art. 7403/LT1**

**MATA**



Lampada in vetro colato, marmo e alluminio verniciato  
Lamp made of poured glass, marble and painted aluminum

<b>Struttura / Frame</b>	<b>Diffusore / Diffuser</b>	<b>Elementi / Elements</b>	<b>Illuminazione / light source</b>
 V2945 Argento scuro Dark silver	 Cristallo retrosatinato Crystal frosted back   Pesca retrosatinato Peach frosted back	 Marmo Carrara Marble Carrara   Marmo Emperador Marble Emperador   Marmo Marquina Marble Marquina	110 / 240V 1 x LED BOARD 8W 800lm 3000K Incluso / Included

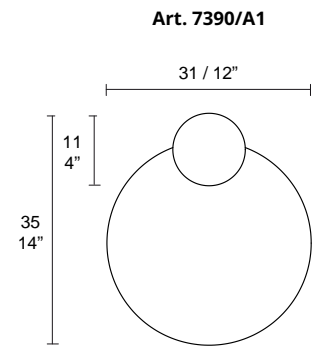



Dimmerabili con dimmer a Controllo di fase o Taglio di fase  
DIM Dimmable by Trailing or Leading Edge Dimmers  
CE    

**MMM****MILA**

Lampada in metallo verniciato e vetro borosilicato  
Painted metal lamp and borosilicate glass

<b>Struttura / Frame</b>	<b>Diffusore / Diffuser</b>	<b>Illuminazione / light source</b>
 V0199 Nero opaco Matt black	 Rosso prugna Red plum,	 15W E14 Classic P45

Lampadina non compresa / Bulb not included.

CE    

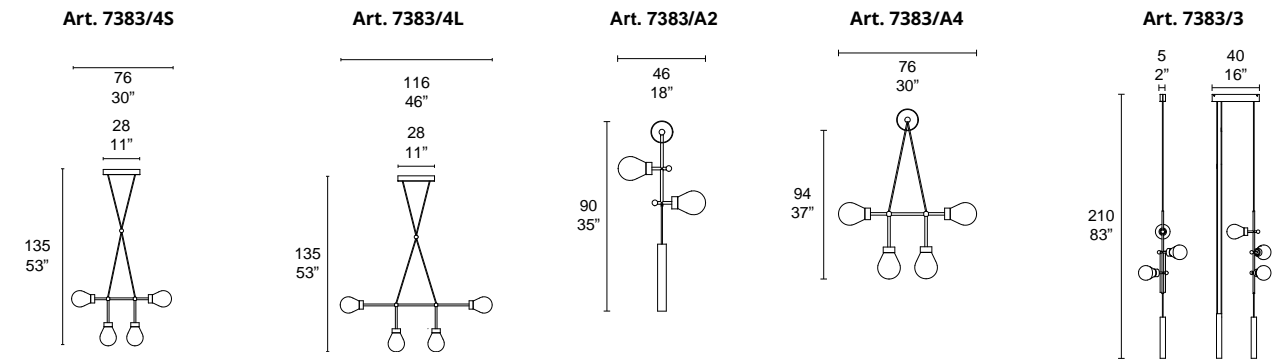

**MOONLIGHT**

Lampada in metallo verniciato o trattamento galvanico con diffusore in PMMA  
Painted metal lamp or galvanic treatment with PMMA diffuser

Struttura / Frame	Diffusore / Diffuser	Illuminazione / light source
<ul style="list-style-type: none"> <li><span style="display: inline-block; width: 10px; height: 10px; background-color: black; border-radius: 50%; margin-right: 5px;"></span> V0199 Nero opaco Matt black</li> <li><span style="display: inline-block; width: 10px; height: 10px; background-color: #c08060; border-radius: 50%; margin-right: 5px;"></span> V2805 Ottone satinato Satin brass</li> </ul>	<ul style="list-style-type: none"> <li><span style="display: inline-block; width: 10px; height: 10px; border: 1px solid black; border-radius: 50%; margin-right: 5px;"></span> Bianco Opale Ice White</li> </ul>	<ul style="list-style-type: none"> <li> STRIP LED 10W 3000°K 24V</li> </ul>

**MMM**

**MYA POP**

Lampada in metallo e vetro Murano incamiciato  
Metal and "Incamiciato" Murano glass lamp

Struttura / Frame	Diffusore / Diffuser	Illuminazione / light source
<ul style="list-style-type: none"> <li><span style="display: inline-block; width: 10px; height: 10px; border: 1px solid black; border-radius: 50%; margin-right: 5px;"></span> V2907 Bianco Opaco Matt white</li> </ul>	<ul style="list-style-type: none"> <li><span style="display: inline-block; width: 10px; height: 10px; background-color: #c05040; border-radius: 50%; margin-right: 5px;"></span> Rosso Olanda Holland Red</li> <li><span style="display: inline-block; width: 10px; height: 10px; background-color: #409090; border-radius: 50%; margin-right: 5px;"></span> Azzurro Vacanze Holiday Blue</li> <li><span style="display: inline-block; width: 10px; height: 10px; border: 1px solid black; border-radius: 50%; margin-right: 5px;"></span> Bianco latte Milky White</li> </ul>	<ul style="list-style-type: none"> <li>8 x max 10W E14 220/240V 16 x max 10W E14 220/240V</li> <li>8 x max 10W E12 100/110V 16 x max 10W E12 100/110V</li> </ul>

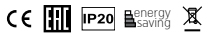

Lampadina non compresa / Bulb not included.

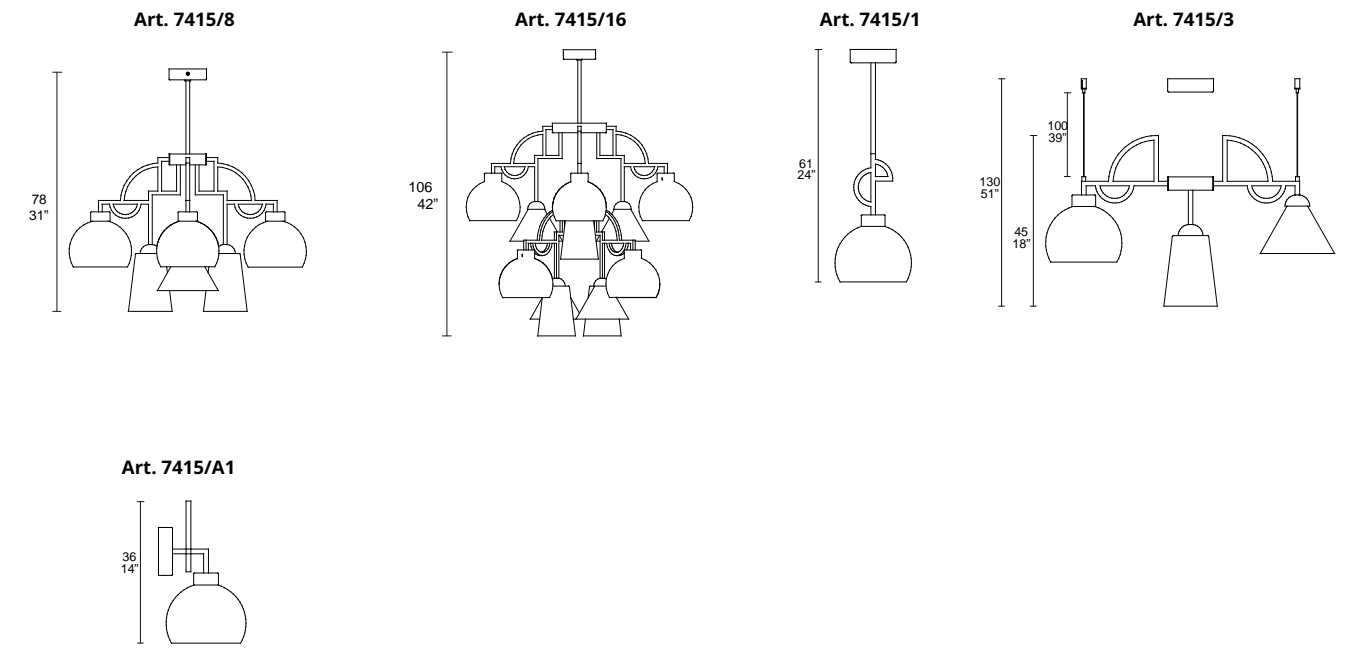
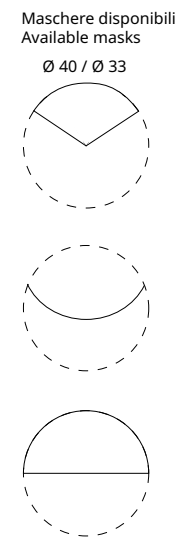
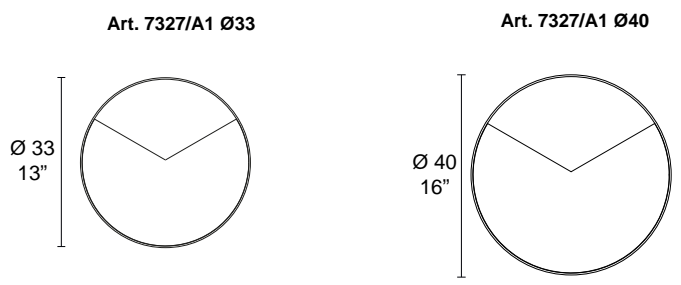
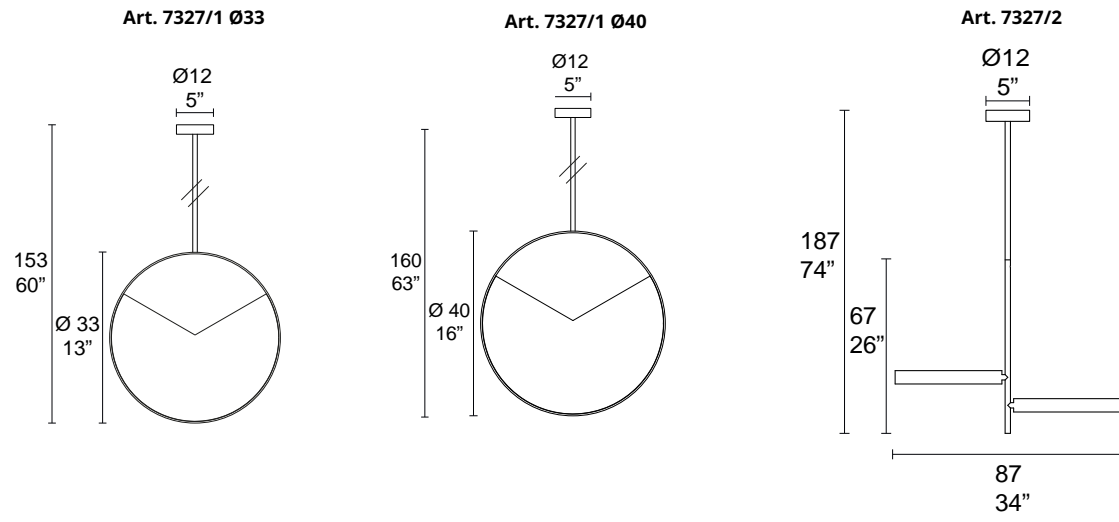



**PAPILLON**

Lampada in metallo verniciato o trattamento galvanico con diffusore in vetro borosilicato  
Painted metal lamp or galvanic treatment with borosilicate glass diffuser

Struttura / Frame      Diffusore / Diffuser      Illuminazione / light source

- V0199  
Nero opaco  
Matt black
- V0216  
Ottone lucido  
Glossy brass
- Bianco  
White
- Su richiesta / On request**
- Ambra  
Amber
- Fumè  
Fumè

 5W G9 LED 220V/240V  

Lampadina non compresa / Bulb not included.

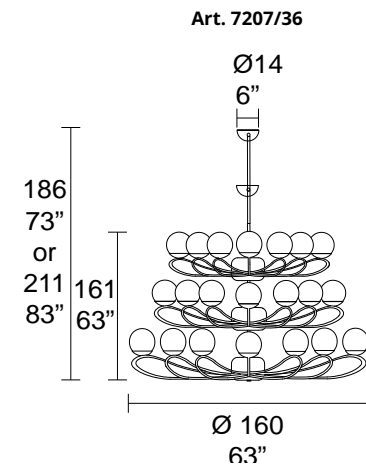
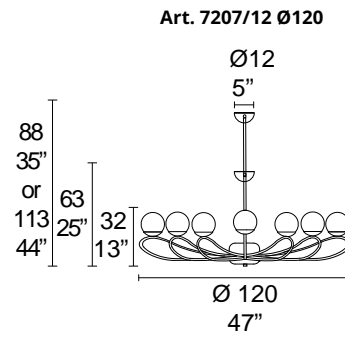
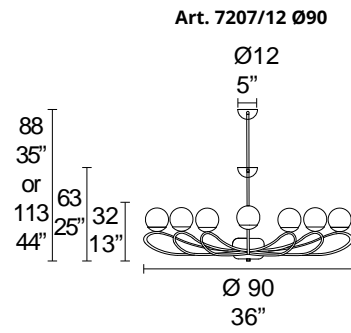
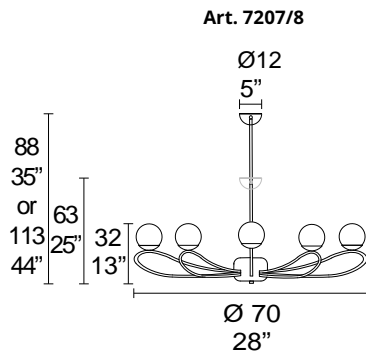



**MMM**

**PARAMOUNT**

Lampada in metallo verniciato o trattamento galvanico  
Painted metal lamp or galvanic treatment

Struttura / Frame      Illuminazione / light source

- V2905  
Ottone ossidato  
Burnished brass  
(struttura esterna)
  - Nero opaco  
Matt black  
(dettagli)
  - V2906  
Nero opaco  
Matt black  
(struttura esterna)
  - Ottone ossidato  
Burnished brass  
(dettagli)
-  20W E27 Filament vintage  
Ø125
- 

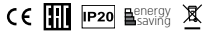

**Art. 7382/LT2 G**

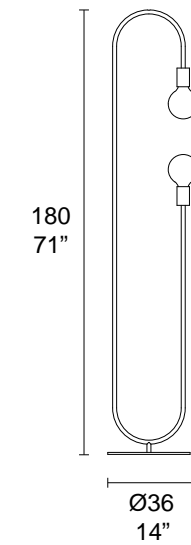

**Art. 7382/L2**

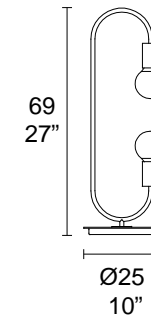



**PINEAPPLE**

Lampada in ceramica con diffusore in vetro di Murano soffiato  
Ceramic lamp with Murano blown glass diffuser

Struttura / Frame      Diffusore / Diffuser      Illuminazione / light source

Base grigio  
RAL 7044  
Silk grey base  
RAL 7044

tabacco  
Tobacco

  
20W E27 LED 220V/240V  

Base gialla  
RAL 1004  
Golden yellow  
base  
RAL 1004

Bianco latte  
Milky White

Base turchese  
pastello RAL 6034  
Turquoise base  
RAL 6034

Bianco latte  
Milky White

Lampadina non compresa / Bulb not included.



Base blu verdastro  
RAL 5001  
Green blue base  
RAL 5001

Bianco latte  
Milky White

Base nero  
RAL 9005  
Black base  
Ral 9005

Bianco latte  
Milky White

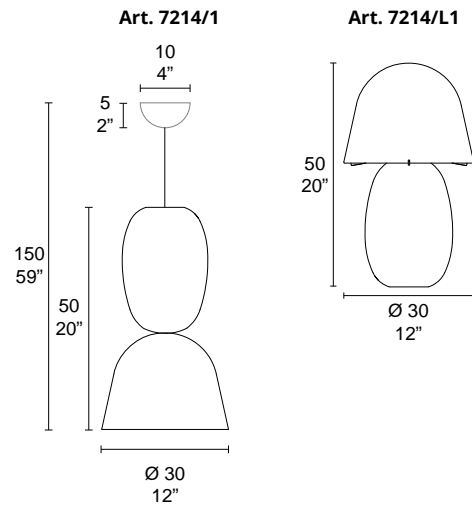

**MMM**

**RAIN**

Lampada in metallo verniciato o trattamento galvanico con diffusore in vetro borosilicato  
Painted metal lamp or galvanic treatment with borosilicate glass diffuser

Struttura / Frame      Diffusore / Diffuser      Illuminazione / light source

V0199  
Nero opaco  
Matt black

Trasparente  
Transparent

  
10W LED E14 Classic  
P45 220V/240V  

Fumé metallico  
Fumé metallic

Satinato  
Frosted

Lampadina non compresa / Bulb not included.

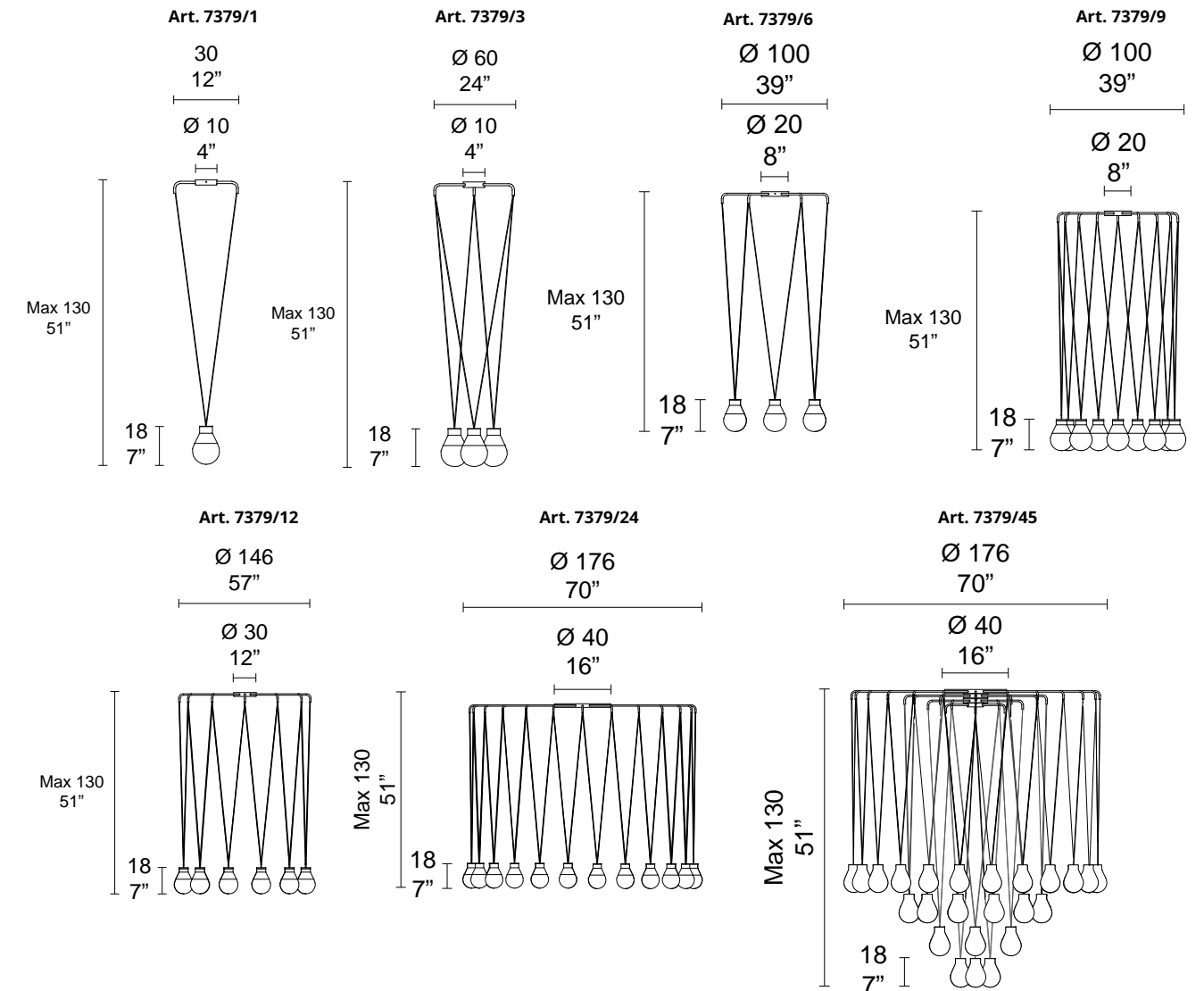
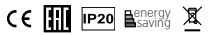

## RIPPLE

Lampada in metallo e vetro soffiato di Murano  
Lamp in metal and blown Murano glass

### Struttura / Frame

V2946  
Brunito verniciato  
Painted burnished

### Diffusore / Diffuser

Bianco latte  
Milky white

### Illuminazione / light source

LED BOARD 10W CRI90 3000°K 220V/240V  
10W E14 LED 220V/240V

LED compreso / LED board included  
Lampadina non compresa / Bulb not included.

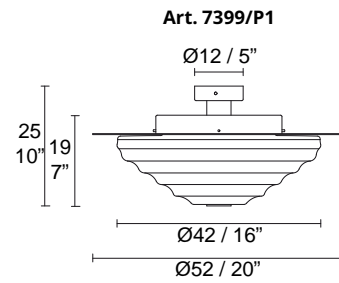
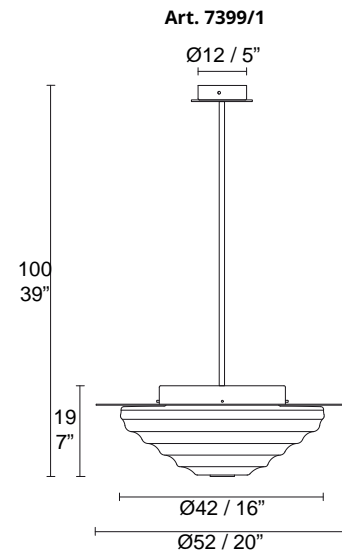

## MMM

## TILTLIT

Lampada in metallo e vetro borosilicato  
Metal and borosilicate glass lamp

### Struttura / Frame

V2907  
Bianco Opaco  
Matt white

V0216  
Ottone lucido  
Glossy brass

### Diffusore / Diffuser

Bianco con vetro rosso frutta  
White with fruit red glass

Bianco Con Vetro Verde Douglas  
White with douglas green glass

Bianco con vetro marrone muschio  
White with moss brown glass

### Illuminazione / light source

1 x max 5W G9 Led 220/240V

Lampadina non compresa / Bulb not included.

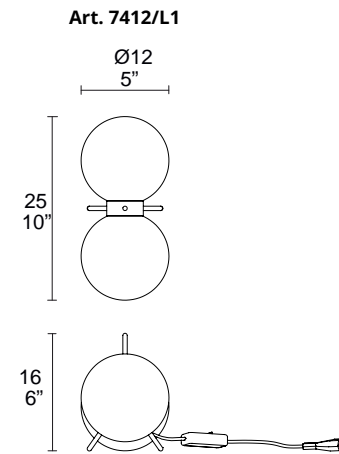
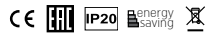



## WHALE

Lampada in metallo verniciato o trattamento galvanico con diffusore in PMMA  
Painted metal lamp or galvanic treatment with PMMA diffuser

### Struttura / Frame

V2907  
Bianco opaco  
Matt white

### Diffusore / Diffuser

Bianco opale  
Ice white

### Illuminazione / light source

    
STRIP LED 45W  
3000°K 3800lm  

V2910  
Vernice oro opaco  
Opaque gold color

Ottone lucido  
Glossy brass

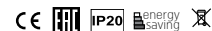
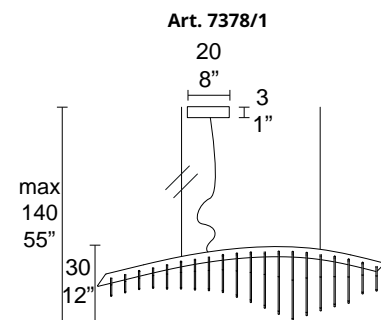

## MMM

### CONDIZIONI GENERALI DI VENDITA

#### 1. Conclusione del contratto

1. Il contratto si intende concluso con la sottoscrizione da parte del Compratore dell'offerta di vendita inviata da MM Lampadari.
2. I contatti fra le parti, sia verbali che scritti, che precedono l'emissione dell'offerta si inseriscono nell'ambito delle trattative precontrattuali e non costituiscono conclusione del contratto, che potrà avvenire nelle sole modalità previste al primo comma.
3. MM Lampadari si impegna a mantenere ferma l'offerta di vendita per 60 giorni successivi alla data di invio, salvo sia diversamente riportato nell'offerta medesima.
4. Ogni modifica delle presenti condizioni dovrà avvenire per iscritto.

#### 2. Agenti e ausiliari del commercio

1. Il Compratore prende atto e riconosce che gli agenti o gli ausiliari del commercio in genere di MM Lampadari, non hanno il potere di vincolare in alcun modo MM Lampadari.
2. Il Compratore non potrà invocare, per l'attribuzione di diritti non conformi a quanto esposto nelle presenti condizioni e nell'offerta di vendita, eventuali deroghe o tolleranze che non risultino espressamente approvate da MM Lampadari.

#### 3. Consegna

1. Il Compratore prende atto che i termini e le indicazioni di consegna indicati nell'offerta di vendita sono meramente indicativi. La data di consegna non può considerarsi termine essenziale.
2. La merce viene prodotta da MM Lampadari in conformità alle disposizioni normative vigenti, in quanto applicabili.
3. La merce viene consegnata da MM Lampadari con il foglio istruzioni. Il Compratore che distribuisce la merce deve sempre mettere in circolazione la merce con il foglio istruzioni. In difetto di quanto appena previsto, il Compratore risponderà nei confronti di MM Lampadari di tutti i danni diretti ed indiretti che la stessa abbia in conseguenza a patirne.
4. Salvo venga diversamente pattuito fra le parti, la resa della merce si intende ex works.
5. A prescindere dai termini di resa pattuiti, il Compratore prende atto e accetta che la merce viaggia a proprio esclusivo rischio. L'obbligo di consegna della merce da parte di MM Lampadari si ritiene in ogni caso adempiuto nel momento in cui MM Lampadari consegna la merce al vettore o allo spedizioniere. I rischi passano al Compratore al più tardi con la consegna al primo trasportatore o, qualora il Compratore non ritiri la merce a tempo debito, a partire dal momento in cui la merce viene messa a sua disposizione ed in cui commette un'inadempienza al contratto non prendendola in consegna.
6. Il Compratore riconosce di non aver facoltà né di rifiutare la merce consegnata né di rendere la stessa, se non nel rispetto di quanto previsto al successivo articolo 5.
7. Il rifiuto della merce da parte del Compratore e/o la restituzione della stessa al di fuori del meccanismo indicato nell'articolo 5, costituirà per MM Lampadari motivo di risoluzione immediata del contratto ex art. 1456 c.c., con facoltà per la stessa di trattenere le somme già incassate a titolo di penale. Detta facoltà non viene meno in caso di emissione da parte di MM Lampadari della nota di credito o di documento equipollente, in conseguenza del rifiuto della merce e/o della resa della stessa.
8. Salvo il caso di dolo o colpa grave di MM Lampadari, è, in ogni caso, espressamente escluso qualsiasi risarcimento del danno per mancata o ritardata consegna della merce in favore del Compratore.

#### 4. Pagamento

1. Il Compratore si obbliga ad effettuare i pagamenti dovuti con le modalità e nei termini indicati nell'offerta di vendita.
2. MM Lampadari avrà la facoltà, qualora non riceva il pagamento in base alle modalità indicate nell'offerta di vendita, di considerare il Compratore inadempiente e di risolvere ex art. 1456 c.c. il contratto, trattenendo a titolo di penale convenzionale l'importo ricevuto a titolo di acconto, salvo il maggior danno.
3. Salvo patto contrario, i prezzi si intendono per la merce imballata secondo gli usi del settore, essendo inteso che ogni spesa o onere sarà a carico del Compratore. Le spese di trasporto sono a carico del Compratore, salvo sia diversamente indicato nell'offerta di vendita.
4. Il Compratore non è autorizzato ad effettuare alcuna deduzione dal prezzo pattuito, neppure in caso di pretesi difetti di non conformità della merce, se non previo accordo scritto con MM Lampadari.

#### 5. Reclami e reso merce

1. Il Compratore si impegna ad effettuare un diligente controllo della merce al momento del suo ricevimento. Eventuali reclami sulla merce consegnata dovranno essere denunciati direttamente per iscritto a MM Lampadari entro i termini di legge (otto giorni dal ricevimento della merce in caso di vizi apparenti, otto giorni dalla scoperta in caso di vizi occulti, intendendosi per tali vizi non individuabili mediante il diligente controllo cui il Compratore è tenuto al momento del ricevimento della merce) e dovranno specificare con precisione il vizio e/o difetto riscontrato e la merce a cui si riferiscono. In ogni caso, fermi restando i termini di denuncia suddetti, la garanzia legale fornita da MM Lampadari si prescrive in un anno dalla consegna della merce. Il Compratore prende atto che non saranno ritenute valide dichiarazioni e/o reclami fatti all'agente o altro ausiliario del commercio.
2. Il Compratore prende atto e riconosce che: i) non costituiscono vizi e/o difetti le eventuali mancanze di uniformità nelle tonalità e/o nel disegno delle decorazioni, essendo queste caratteristiche delle lavorazioni a mano dei prodotti; ii) MM Lampadari non risponderà di danni determinati da errato montaggio o improprio utilizzo della merce da parte del Compratore e/o in caso di mancata osservanza da parte di questi del foglio istruzioni; iii) a pena di decadenza dalla garanzia per vizi e/o difetti, la merce oggetto di reclamo dovrà essere adeguatamente custodita dal Compratore in modo da non comprometterne le caratteristiche estetiche e funzionali (a titolo esplicativo la merce dovrà essere custodita al riparo da intemperie e condizioni atmosferiche avverse); iv) MM Lampadari non sarà ritenuta responsabile del normale consumo dei materiali (quali sorgenti luminose, guarnizioni, batterie); v) MM Lampadari non sarà ritenuta responsabile qualora il non funzionamento della merce consegnata dipenda dall'uso di materiali non originali o inadeguati (quali l'utilizzo lampadine non adatte in base alla scheda tecnica fornita); vi) MM Lampadari è esente da responsabilità qualora l'impianto elettrico, dove sono installati i prodotti, non permetta il funzionamento del lampadario fornito o danneggi le sorgenti luminose integrate fornite.
3. Il Compratore rinuncia espressamente al diritto di regresso nei confronti di MM Lampadari anche ai sensi dell'art. 134 D. Lgi 206/2005, ferma restando la responsabilità di MM Lampadari in caso di prodotto difettoso ex art. 115 e ss D. Lgi 206/2005.
4. Il reso della merce è subordinato alla preventiva denuncia di vizi e/o difetti secondo le modalità stabilite al successivo comma e all'autorizzazione scritta di MM Lampadari al reso.
5. Qualora MM Lampadari autorizzi il Compratore a rendere la merce, il controllo della merce medesima verrà effettuato presso MM Lampadari, salva diversa indicazione di questa. Qualora MM Lampadari verifichi l'esistenza di vizi e/o difetti denunciati della merce, il Compratore avrà diritto, a scelta insindacabile di MM Lampadari, alla sostituzione della merce difettosa o al rimborso del prezzo pattuito per la vendita della merce difettosa. Il Compratore rinuncia espressamente alla richiesta nei confronti di MM Lampadari di qualsivoglia risarcimento del danno o indennità. La merce resa viaggia a spese e a rischio del Compratore.
6. E' inteso che eventuali reclami sulla merce non danno diritto al Compratore di sospendere o comunque ritardare i pagamenti della merce oggetto di contestazione, né, tanto meno, di altre forniture.

#### 6. Autotutela

1. Qualora MM Lampadari abbia motivo di temere che il Compratore non possa o non intenda pagare la merce alla data pattuita, potrà: i) sospendere la consegna della merce; ii) subordinare la consegna della merce all'integrale pagamento di quanto dovuto o all'osservanza di termini e modalità di pagamento diversi rispetto a quelli indicati nell'offerta di vendita; iii) subordinare la consegna della merce alla prestazione di garanzie di pagamento.
2. In caso di mancati, ritardati pagamenti anche relativi a diverse forniture, MM Lampadari potrà modificare unilateralmente i termini e le modalità di pagamento anche delle altre forniture e/o sospendere l'esecuzione fino all'ottenimento del pagamento e/o di adeguate garanzie di pagamento.

#### 7. Forza Maggiore

1. Qualora si verifichi un evento imprevedibile fuori dal controllo delle Parti e che renda l'esecuzione del singolo contratto di vendita impossibile (quali a titolo esemplificativo e non esaustivo, terremoti e altre calamità naturali di grave portata, epidemie, emergenze sanitarie, scioperi, guerra, dichiarata o non, sommosse o rivoluzioni, boicottaggi, embarghi, eventi riferibili anche riferibili agli eventuali fornitori di MM Lampadari), le Parti potranno sospendere l'esecuzione. 2. Ciascuna parte dovrà comunque informare prontamente l'altra dell'insorgere della circostanza di forza maggiore e prendere tutti i provvedimenti atti a limitarne gli effetti, limitatamente a quanto in suo potere.

#### 8. Legge applicabile

1. Il presente contratto è regolato dalla legge italiana.
2. Qualsiasi riferimento a termini commerciali è da intendersi come richiamo agli Incoterms della Camera di Commercio Internazionale, nel testo in vigore alla data di stipulazione del contratto.

#### 9. Foro competente

1. Per ogni controversia nascente dalla validità, interpretazione o esecuzione del contratto sarà esclusivamente competente il Giudice del luogo in cui ha sede MM Lampadari.

## GENERAL SALES TERMS

### 1. Entering into the Contract

- The Contract is entered into upon the Purchaser signing the Offer of Sale sent by MM Lampadari.
- Contacts made between the Parties, both verbal and written, that precede an Offer being issued form part of the pre-contractual negotiations and do not constitute the conclusion of the Contract, which may happen only in the ways established in the first clause.
- MM Lampadari undertakes to maintain the validity of the Offer of Sale for 60 days from the sending date, unless otherwise stated in the Offer itself.
- Any amendment of these conditions shall be made in writing.

### 2. Sales Agents and Auxiliaries

- The Purchaser acknowledges and accepts that MM Lampadari agents and trade auxiliaries in general do not have the power to bind MM Lampadari in any way whatsoever.
- The Purchaser shall not be entitled to invoke, for the attribution of rights that do not comply with these conditions or the Offer of Sale, any derogations or tolerances that are not expressly approved by MM Lampadari.

### 3. Delivery

- The Purchaser acknowledges that the delivery terms and instructions stated in the Offer of Sale are purely indicative. The delivery date cannot be considered a binding deadline.
- The goods are produced by MM Lampadari in compliance with the regulations in force, as applicable.
- The goods are delivered by MM Lampadari accompanied by an instruction sheet. The Purchaser distributing the goods shall also dispense the goods with the aforementioned instructions sheet. Failing to observe the above, the Purchaser will be liable towards MM Lampadari for all direct and indirect damages that may be suffered as a result.
- Unless otherwise established between the Parties, the goods shall be delivered ex works.
- Regardless of the agreed upon terms of return, the Purchaser acknowledges and accepts that the goods travel at the Purchaser's own exclusive risk. MM Lampadari's obligation to deliver the goods is, in any case, understood as being fulfilled upon MM Lampadari handing over the goods to the courier or shipper. The risks pass to the Purchaser, at the latest, with delivery to the first transporter or, if the Purchaser does not collect the items in good time, from the moment at which the goods are made available to the Purchaser or upon the Purchaser breaching the Contract by not taking delivery of the goods.
- The Purchaser accepts that the same has no right neither to refuse the goods delivered nor to return the same, if not in compliance with that set forth in Article 5 below.
- The rejection of the goods by the Purchaser and/or their return outside the mechanism indicated in Article 5 shall constitute grounds for immediate termination of the Contract for MM Lampadari, with the right for the same to retain the sums already collected by way of penalty. This right shall not lapse if MM Lampadari issues a Credit Note or equivalent document as a consequence of the rejection of the goods and/or their return.
- Except in the case of wilful misconduct or gross negligence by MM Lampadari, any compensation for damage due to missed or late delivery of the goods in favour of the Purchaser is, in any case, expressly excluded.

### 4. Payment

- The Purchaser undertakes to make the payments due with the means and under the terms indicated in the Offer of Sale.
- If payment is not received in accordance with the terms indicated in the Offer of Sale, MM Lampadari shall have the right to consider the Purchaser in default and to terminate the Contract pursuant to Article 1456 of the Italian Civil Code, withholding the amount received as a payment on account by way of conventional penalty, without prejudice to any greater damages.
- Unless where otherwise agreed, the prices are understood as being for packaged goods based on industry uses, it being tacit that any expense or charge will be borne by the Purchaser. Transport costs shall be paid by the Purchaser, unless otherwise indicated in the Offer of Sale.
- The Purchaser is not authorised to make any deduction to the established price, not even in the event that alleged non-conformities are claimed, unless otherwise agreed upon in writing with MM Lampadari.

### 5. Complaints

- Any claims relative to any apparent non-conformity, taken as meaning the presence of faults in the external characteristics of the goods, shall be reported by the Purchaser – at the risk of forfeiture – in writing to MM Lampadari within 8 (eight) days from receiving the same. The Purchaser commits to the goods being submitted to suitable, diligent checks upon receipt.
- Any claims relative to hidden non-conformities, taken to mean faults that are not immediately noticeable via a suitable, diligent check which the Purchaser is to perform upon receipt of the goods, shall be reported by the Purchaser – at the risk of forfeiture – in writing to MM Lampadari within 8 (eight) days from such non-conformity being detected and, in any case, no later than twelve months from the same being delivered.
- The Purchaser acknowledges and recognises that: i) any lack of uniformity in the shades and/or design of the decorations does not constitute a defect and/or fault, as these are characteristics of the hand-made workmanship of the products; ii) MM Lampadari shall not be liable for any damages caused as a result of incorrect assembly or improper use of the goods by the Purchaser and/or in the event of failure by the latter to comply with the instruction sheet; iii) under penalty of forfeiture of the warranty for defects and/or faults, the goods subject to any claim shall be properly stored by the Purchaser in such a way as not to compromise their aesthetic or functional characteristics (by way of mere example, the goods are to be stored protected from inclement weather and adverse atmospheric conditions); iv) MM Lampadari shall not be held responsible for the normal consumption of materials (such as light sources, seals, batteries); v) MM Lampadari shall not be held liable if the non-functioning of the goods delivered is due to the use of non-original or inappropriate materials (such as the use of light bulbs that are not suitable according to the technical data sheet supplied); vi) MM Lampadari shall not be held liable if the electrical system of the sites where the products are installed does not permit operation of or causes damage to the integrated light sources supplied.
- Any claim shall clearly specify the non-conformity detected and the goods to which the same refers. Returning goods for the purposes of checking the same is, in any case, subject to the non-conformity having been reported in advance, in compliance with that set forth in this Article and upon the written authorisation of MM Lampadari for the return to be effectuated. If MM Lampadari authorises the Purchaser to return the goods, the goods will be checked by MM Lampadari at its facility, save any other provisions being established. If, after carrying out its check, MM Lampadari confirms the existence of the non-conformity, that set in the following Article shall apply. Returned goods travel at the Purchaser's expense and risk.
- The period of limitation indicated in this Article is considered as being reasonable by both Parties.

### 6. Warranty on the goods

- MM Lampadari commits to remedying any non-conformity in the goods that is attributable to the same and which is confirmed within twelve months from the goods being delivered to the Purchaser, provided that such a non-conformity has been promptly reported in compliance with that set out in Article 5 above. A period of twelve months is agreed between the Parties in express derogation of that set forth in Article 39 of the Vienna Convention.
- In the case set out in the preceding clause, MM Lampadari will remedy any non-conformity, at its sole discretion providing for the replacement or repair of the goods (or parts thereof) found to be defective. If replacement or repair is not possible, MM Lampadari may reimburse the Purchaser the price paid for the goods found to be defective.
- The Purchaser expressly waives the right of recourse against MM Lampadari also pursuant to Article 134 of Italian Legislative Decree 206/2005 (or similar provision based on Article 3 of European Directive 1999/44/EC dated 25th May 1999).
- The obligations assumed by MM Lampadari with this Article are exhaustive and replace any warranty or liability established by law. It is thus agreed that MM Lampadari is expressly relieved of any other contractual and/or extra-contractual liability, except in cases of wilful misconduct or gross negligence by MM Lampadari, whereby originating from the Products provided and/or their resale (including, by way of mere example, compensation for direct and/or indirect damages, lost earnings, cancelled orders and penalties).
- If claims or demands by third parties are made regarding defective goods, the Purchaser who distributes the goods shall refrain – at the risk of voiding the warranty – from making any allowance, admission or offer of any nature whatsoever.

### 7. Self-protection

- If MM Lampadari has reason to fear that the Purchaser cannot or does not wish to pay for the goods by the date agreed, MM Lampadari may: i) suspend the delivery of goods; ii) subject the delivery of the goods to the full payment of that due or to payment terms and means different to those indicated in the Offer of Sale; iii) subject the delivery of the goods to suitable payment guarantees being made.
- In the case of missed or late payments, including those relative to other supplies, MM Lampadari may unilaterally amend the payment terms and means, including those relating to other supplies, and/or suspend the execution of such until payment has been received and/or suitable payment guarantees have been made.

### 8. No waiver

- Any tolerance by the fulfilling Party of conduct of the other Party regarding the obligations set out under this Contract shall not be deemed as a waiver of the fulfilling Party's rights, even if such conduct is reiterated or continued.

### 9. Force Majeure

- In the event of an unforeseeable event beyond the control of the Parties and which renders the execution of an individual Contract of Sale impossible (such as, by way of mere example, earthquake or other major natural disaster, epidemic, health emergency, strike, war – declared or otherwise, a revolt or revolution, boycott, embargo or any event that might even be attributable to other MM Lampadari suppliers), the Parties may suspend such execution. 2. Each party shall, in any case, promptly notify the other of any situation of force majeure which may arise and shall take every measure to limit its effect, to the extent within its power.

### 10. Applicable Law

- This Contract of Sale is governed by the United Nations Convention on Contracts for the International Sale of Goods (CISG; the Vienna Convention, 1980) and, for matters not covered therein, by Italian law.
- Any reference to commercial terms is understood as a reference to the Incoterms of the International Chamber of Commerce, in the text in effect on the date that this Contract is signed.

### 11. Jurisdiction

- Any dispute that may arise from the validity, interpretation or execution of this Contract shall be dealt with under Italian law and jurisdiction, with the Judge in the location where MM Lampadari is based having exclusive ruling powers.

### 12. Final Provisions

- This Contract, along with any correlated documents, is drawn up in the English language. Communications between the Parties shall be in the English language. The Parties declare knowing and being familiar with the English language.
- Any amendment to these Conditions shall be made in writing.

## Certifications



Prodotto conforme ai requisiti essenziali per la commercializzazione ed utilizzo nell'Unione Europea.  
Product in compliance with the essential requirements for the marketing and use in the European Union.



Prodotto conforme a tutte le normative tecniche delle procedure di valutazione dell'Unione doganale eurasiatica.  
Product complies with all technical regulations of the Eurasian Customs Union evaluation procedures.



Utilizzo da interno  
Indoor use



Utilizzo da esterno  
Outdoor use



Prodotto dimmerabile  
Dimmable



Lampadina non dimmerabile  
Non-Dimmable Bulb



Tensione d'uso  
Voltage



Tensione d'uso  
Voltage



Lampadina a LED sostituibile  
Replaceable LED bulb



Non protetto contro l'ingresso di liquidi  
Not protected against liquids permeation



Modulo LED integrato non sostituibile  
Integrated non-replaceable LED module



Modulo LED integrato sostituibile  
Integrated replaceable LED module



Da installare con foro per incasso  
Recessed installation



Prodotto orientabile  
Swiveling Product



Peso netto  
Net weight



Peso lordo  
Gross weight

Type	Lampadine led / Led bulbs	Watt
E14		10W
E27		20W
G9		5W
Gx53		8W
GU 10		15W



Lampadina dimmerabile. La compatibilità con i sistemi di dimmerazione è indicata nelle specifiche di ogni prodotto  
Dimmable bulb. Compatibility with dimming systems is indicated in the specs of each product.



Lampadina non dimmerabile - Not Dimmable

**VISUAL DIRECTION AND STYLING**

GIORGIO BISCARO  
M.M. LAMPADARI

**STUDIO PRODUCTION,  
SET DESIGN & STYLING**

M.M. LAMPADARI  
LAURA POZZI

**PHOTOGRAPHY**

ASOLANAGROUP  
ANTONIO CAMPANELLA  
ALESSANDRO DI BON  
FEDERICO MARIN  
STUDIO ROCCI

**COLOUR CALIBRATION**

GM STUDIO1

**THANKS TO**

AGAPE  
ARLEX ITALIA  
CERAMICHE MILESI  
COLLEZIONI  
DOIMO CUCINE  
F.LLI CALEGARO  
HAFROGEROMIN  
IL CESELLO  
JESSE  
KASTHALL  
KREOO  
LEMA  
LITTLE OWL  
MADE A MANO  
MARAZZI GROUP  
MATTEO PALA  
MATTEO ZORZENONI  
MAURO BOLOGNESI  
MINIFORMS  
MOLTENI & C  
MOROSO  
OFFICINA N°3  
SCAPIN  
SCULPTURE JEUX  
SONIA PEDRAZZINI  
RONCATO VALIGERIA  
RUBINETTERIA GIULINI  
WOOBAG  
WOODMOON

Tutti i prodotti MM Lampadari S.r.l. sono conformi alle direttive Europee in vigore. Ogni articolo prodotto presentato nel catalogo é realizzato e decorato artigianalmente, pertanto lievi differenze nelle dimensioni, nel colore o nei dettagli costituiranno il carattere di unicità proprio della lavorazione manuale.

*All MM Lampadari S.r.l. Products comply with the European directives in force. Each product presented in the catalogue is produced and decorated by hand; therefore, slight colour, size or detail differences will make the unique character in the handwork.*

MM Lampadari S.r.l. si riserva il diritto di intervenire in qualunque momento e senza preavviso per apportare le modifiche che ritenesse più opportune per migliorare il prodotto o in risposta a qualsiasi esigenza di carattere normativo costruttivo o commerciale.

*MM Lampadari S.r.l. reserves its right to intervene in every moment and without forewarning in order to make the modifications more suitable to improve the product or reply to each legal, manufacturing or commercial requirement.*



© M.M. LAMPADARI. È vietata la riproduzione anche parziale di questo catalogo

© M.M. LAMPADARI. It is forbidden to reproduce any part of this catalogue

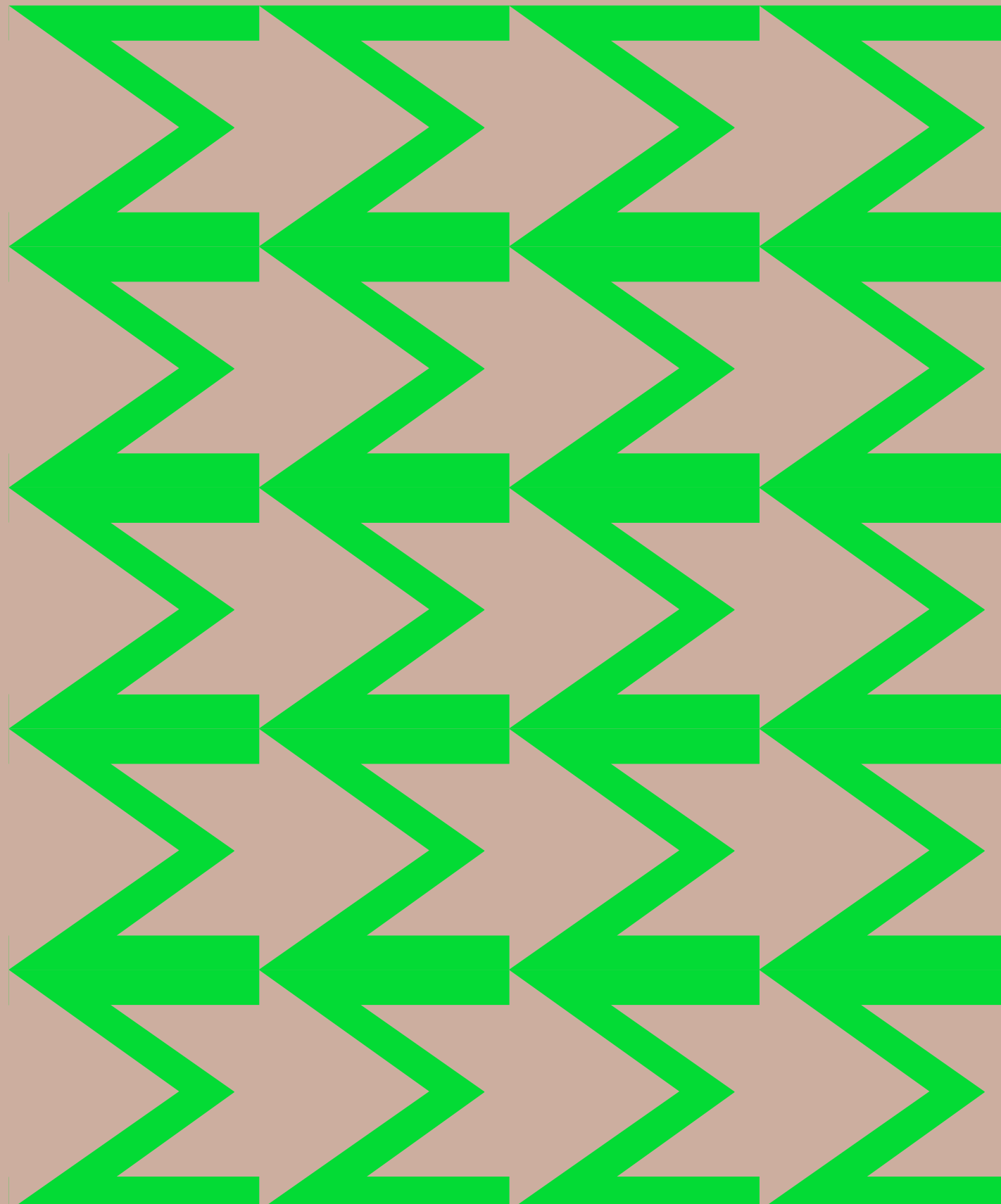



**mm**lampadari