

MARQUISE

2024



mmlampadari

MARQUISE

Per la nuova edizione del nostro catalogo abbiamo pensato fosse ormai diventato limitante pensare a due sole collezioni intestandole a un tema Classico e a un tema Design: le sfumature progettuali sono infinite, e la nostra attenzione al prodotto ci ha portato a riconsiderare la stessa semantica delle collezioni per condensarle in visioni, più che aggettivi, e trasferire quindi all'osservatore un'esperienza di prodotto, anziché approssimarla in un attributo. Il catalogo che state sfogliando è frutto di una meticolosa revisione di quanto MM ha creato negli anni, operata pensando all'habitat, alla personalità e allo stile di vita che abbiamo immaginato caratterizzare i nostri clienti.

Un taglio preciso, netto. Duro nella sua azione di affinare il grezzo, per rendere luminosa la pietra più irregolare: questa è la collezione Marquise, fatta di dettagli rigorosi, lucentezza adamantina, riflessi preziosi. Ospita i prodotti MM più raffinati, più eleganti, misurati: una collezione che ha radici nella felice tradizione dell'illuminazione italiana ma allo stesso tempo ne reinterpreta linguaggi, stilemi, grammatica per confezionare un prodotto senza tempo, familiare, e rassicurante malgrado la sua rigidità formale.

For the new edition of our catalog we thought it had now become limiting to think of just two collections, naming them with a Classic theme and a Design theme: the design nuances are infinite, and our attention to the product has led us to reconsider the very semantics of the collections to condense them into visions, rather than adjectives, and therefore transfer a product experience to the observer, rather than approximating it in an attribute. The catalog you are browsing is the result of a meticulous review of what MM has created over the years, carried out thinking about the habitat, personality and lifestyle that we imagined characterizing our customers.

A precise, clean cut. Harsh in its action of refining the rough, to make the most irregular stone luminous: this is the Marquise collection, made of rigorous details, adamantine shine, precious reflections. It houses the finest, most elegant, measured MM products. A collection that has roots in the happy Italian lighting tradition but at the same time reinterprets its languages, styles and grammar to create a timeless, familiar and reassuring product despite its formal rigor.

DA OLTRE 50 ANNI INTERPRETIAMO LA MATERIA PER CREARE OPERE DI LUCE

MM Lampadari nasce nel 1966, mezzo secolo che ci ha visti crescere e diventare una tra le più importanti realtà italiane nel settore dell'illuminazione d'interni a livello internazionale.

Quello che ci contraddistingue è la grande abilità di plasmare la materia secondo le tradizionali tecniche di lavorazione del ferro, che ancora oggi viene battuto a mano da esperti artigiani.

Lo stile MM Lampadari è uno stile ben definito, il nostro è un lavoro fatto con passione che crea vere e proprie opere d'arte artigiana per illuminare ogni ambiente con gusto e unicità.

Siamo stilisti dell'illuminazione, capaci di fondere in un'unica creazione il metallo e il vetro di Murano. Siamo custodi di un sapere antico ma sappiamo guardare anche al futuro proponendo pezzi storici in chiave moderna e realizzazioni dal gusto puramente contemporaneo.

WE'VE BEEN SHAPING RAW MATERIALS TO CREATE LIGHT ARTWORKS FOR MORE THAN 50YRS

MM Lampadari was founded in 1966, and for more than half a century we have been growing and expanding ourselves, becoming one of the most important reality of the Italian lighting field on an international level. Our great ability to shape iron through traditional techniques and the work of experienced artisans is what makes stand us out.

MM lampadari well-defined style and the passion we put into our creations are the things that make us create handcrafted masterpieces.

We are lighting designers, able to melt together metal and Murano glass. Our aim is the one of illuminating every space with style and distinctiveness, learning from our past traditions but always looking at the future, offering past designs through modern shapes and contemporary realizations.



GLI OPPOSTI SI FONDONO IN PERFETTA ARMONIA

I protagonisti delle realizzazioni MM Lampadari sono da sempre due materiali considerati agli antipodi tra loro: il vetro soffiato e il ferro forgiato a mano.

Sono molti gli elementi che li accomunano, una tra tutti l'abilità che necessitano per essere lavorati. MM Lampadari ha fatto tesoro di anni di esperienza, ha raccolto i migliori artigiani e con loro ha carpito i segreti della lavorazione fatta a mano del ferro e del vetro. I risultati sono prodotti in cui l'armonia tra i materiali spicca fin dal primo sguardo. I nostri maestri artigiani sanno come creare equilibrio tra pieno e vuoto, tra leggerezza e solidità. Conoscono le antiche tecniche che permettono di fondere il vetro nel metallo, creando un unico corpo perfettamente bilanciato. Questa unione è sempre alla base delle realizzazioni dell'azienda che l'ha declinata sia negli stili più classici, sia in forme più innovative e dalla nuova concezione estetica.

OPPOSITES MELT TOGETHER IN HARMONY.

Handmade forged-iron and blown glass: these are the main elements of our products.

Different elements with same needs, as the experience required to shape them. MM Lampadari, with its long-lasting experience and best artisans creates harmony between opposites, balancing emptiness and fullness, lightness and solidity. We know all ancient techniques that allow us to melt iron and glass together, creating perfectly balanced shapes.

This union has always been the basis for our realizations, applying it to both our classic and innovative designs, creating a new aesthetic vision.



MM LAMPADARI, UN PONTE TRA TRADIZIONE E MODERNITÀ

In questa edizione del nostro catalogo abbiamo voluto mettere in evidenza le nostre due anime: una molto forte legata alla tradizione, ad un sapere antico di cui siamo custodi, l'altra che guarda al futuro per traghettare nell'era contemporanea il gusto classico del passato.

Per questo abbiamo creato due sezioni distinte nel catalogo, una dedicata alle raffinate linee classiche e una che mette in mostra le nostre reinterpretazioni dei canoni tradizionali, per raccontare a rovescio i prodotti e a rovescio la luce questi due volti della nostra azienda, dove l'equilibrio tra le parti è da sempre la nostra parola d'ordine.

MM LAMPADARI, A BRIDGE BETWEEN TRADITION AND MODERNITY

This new edition of our catalogue highlights our double nature: the strong soul linked to our traditions and past knowledge, and the innovative one that looks at the future to lead classic designs through contemporaneity.

For this reason, we separated the catalogue into two parts: one focused on the classic designs and the other one, which shows our modern interpretations of classic standards. All of this has been made to show how important balancing different styles is for us and our products

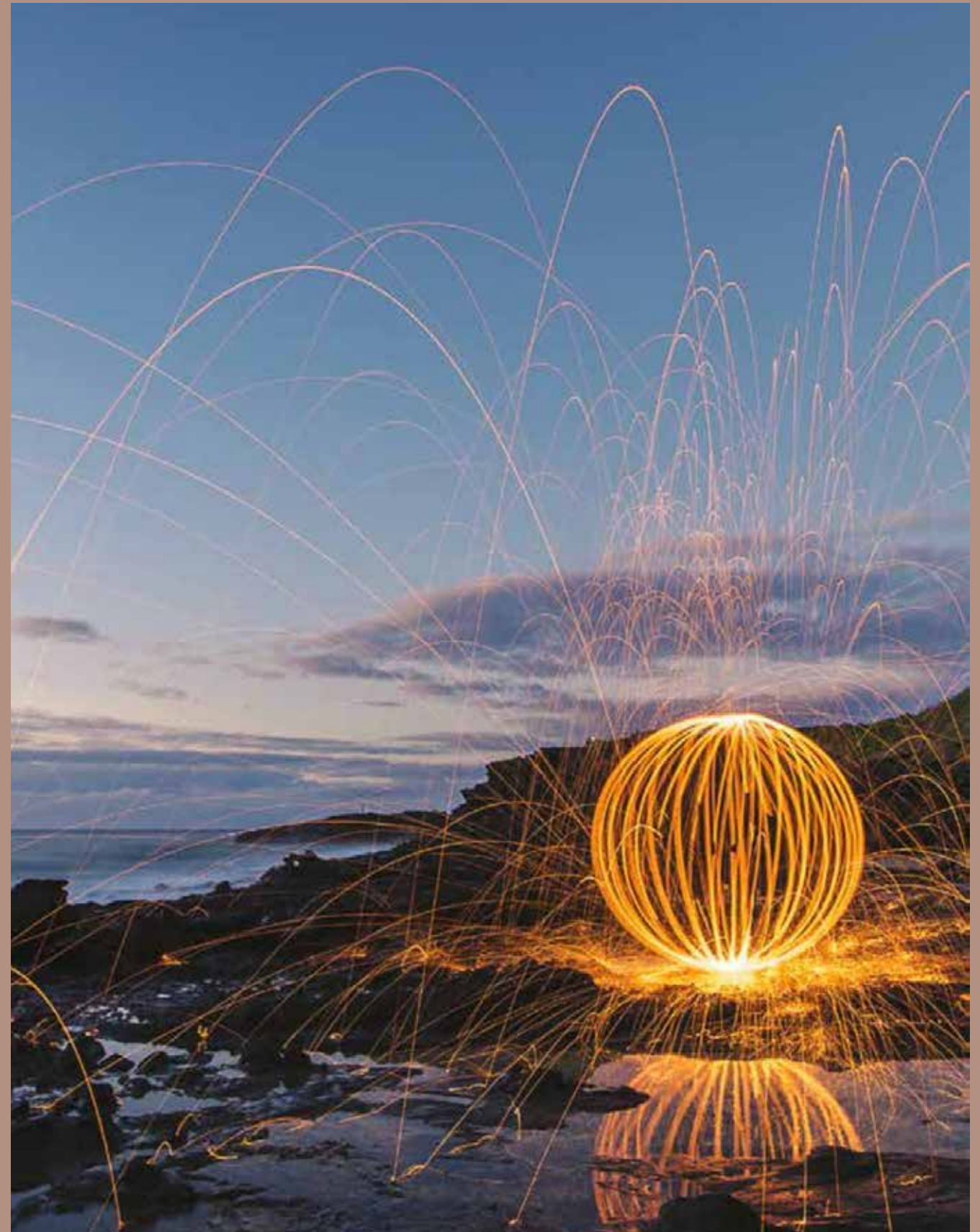

INDEX



AMANITA 16



TUMBLER 22

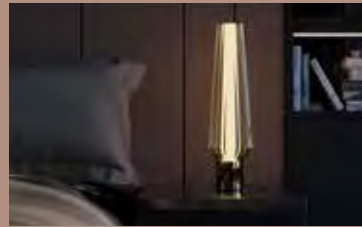

BABILONIA 36



FILI 102



GOCCIA 108

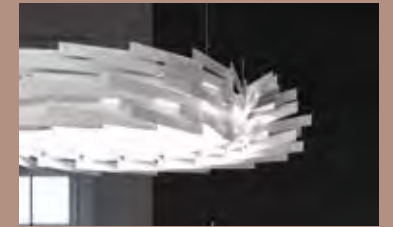

JACK 114



CURL 42



CUSPIDE 48



OPUS 58



MUSEO 120



ORION 126



PERLA 134



FONTAINE 64



MYA 70

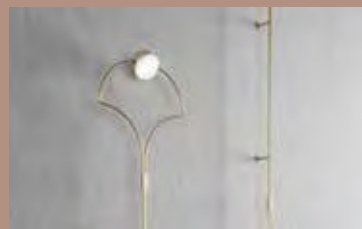

1920 78



PETAL 138



PILL 144



RAYS 150



ARABESQUE 82



BUCCIA 90



CITY 96



SASS 156

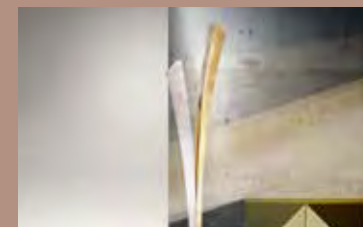

SKY 162

AMANITA

DESIGNED BY MM LAMPADARI WORKSHOP



AMANITA

Un oggetto-scultura che assume una forma astrattamente organica, Amanita si arricchisce di sottili dettagli tramite la luce, che ne esalta gli spessori variabili e si disperde lungo l'altezza del generoso volume in vetro generando un elegante e morbido effetto luminoso, mentre i lussuosi dettagli in metallo lucido ne ingentiliscono ulteriormente l'aspetto.

A sculpture-object that takes on an abstractly organic shape, Amanita is enriched with subtle details through light, which enhances its variable thicknesses and is dispersed along the height of the generous glass volume generating an elegant and soft luminous effect, while the luxurious shiny metal details further refine its appearance.





TUMBLER

DESIGNED BY DANIELE LOSCALZO MOSCHERI



TUMBLER

In una combinazione di riferimenti visivi che ci suggeriscono il raffinato mondo della mixology, la famiglia Tumbler fa sfoggio di elementi da quello mutuati: le preziose molature e le lucenti finiture galvaniche abbinate all'eleganza del nero opaco fanno di ogni creazione un'opera d'arte da ammirare. E da degustare.

In a combination of visual references that suggest the refined world of mixology, the Tumbler family shows off elements borrowed from it: the precious grinding and the shiny galvanic finishes combined with the matte black elegance make each creation a work of art to to admire. And to taste.













BABILONIA

DESIGNED BY MM LAMPADARI WORKSHOP



BABILONIA

La precisa geometria ha profondi richiami nell'architettura antica, e ne esemplifica il senso di imponente proporzione con un diffusore vitreo solido, le cui striature verticali conferiscono verticalità, ordine e rigore. Un secondo diffusore interno aiuta a diffondere la luce, agendo da guida ottica, trasportando la luce attraverso tutto il volume.

The precise geometry has profound references to ancient architecture, and exemplifies the sense of imposing proportion with a solid glass diffuser, whose vertical striations confer verticality, order and rigor. A second internal diffuser helps to diffuse the light, acting as an optical guide, transporting the light throughout the entire volume.





CURL

DESIGNED BY GIORGIO BISCARO



CURL

Volume importante ma grande leggerezza: Curl esalta la vittoria della tecnica sulla materia con la sua solida struttura in metallo curvato, che fa da supporto a un diffusore elegante, caldo, da cui traspaiono le sorgenti luminose. Al centro, come un faro lucente, un elemento in vetro contribuisce a conferire verticalità alla lampada e ne riceve la luce, moltiplicandola quasi fosse un gioiello.

Important volume but great lightness: Curl enhances the victory of technique over matter with its solid curved metal structure, which supports an elegant, warm diffuser, from which the light sources shine through. In the centre, like a shining beacon, a glass element contributes to giving verticality to the lamp and receives the light, multiplying it almost as if it were a jewel.





CUSPIDE

DESIGNED BY MM LAMPADARI WORKSHOP



CUSPIDE

Raffigurazione schematica di una intersezione tra figure geometriche, lineare, solida, rigidamente metallica, eppure ingentilita da delicati diffusori in vetro, decorati da un pattern verticale che li rende setosi all'apparenza, quasi un manufatto tessile. L'alta arte vetraria incontra infine la lavorazione del metallo, artigianalmente conformato, in un elegante connubio di luce e materia.

Schematic representation of an intersection between geometric figures, linear, solid, rigidly metallic, yet softened by delicate glass diffusers, decorated with a vertical pattern that makes them silky in appearance, almost a textile artefact. The high art of glassmaking finally meets the processing of metal, handcrafted, in an elegant combination of light and matter.









OPUS

DESIGNED BY GIORGIO BISCARO



OPUS

Un oggetto sospeso composto, rigoroso, persino duro nei suoi elementi costitutivi, che esprime attraverso il consistente uso del metallo una completa finitezza formale. Una lampada che si auto definisce e si rende evidente, i cui dettagli puntuti compongono una corazza lucente che sembra quasi essere stata messa a difesa dal mondo esterno.

A composed suspended object, rigorous, even hard in its constituent elements, which expresses complete formal finiteness through the consistent use of metal. A lamp that defines itself and makes itself evident, whose pointed details make up a shiny armor that almost seems to have been defended from the outside world.





FONTAINE

DESIGNED BY GIORGIO BISCARO



FONTAINE

Quasi la raffigurazione simbolica di una fontana che zampilla, congelata nell'istante in cui i getti d'acqua creano i tipici luccicanti rivoli, Fontaine fa della trasparenza e della moltiplicazione della luce la sua *raison-d'être*, anche grazie alle sferette di vetro che sostengono visivamente i diffusori soffiati a bocca in una elegante colorazione acciaio.

*Almost the symbolic representation of a gushing fountain, frozen in the instant in which the jets of water create the typical glittering rivulets, Fontaine makes transparency and the multiplication of light its *raison-d'être*, also thanks to the glass spheres which visually support the mouth-blown diffusers in an elegant steel colour.*





MYA

DESIGNED BY LENZIA MONDIN



MYA

Lampada a sospensione con struttura metallica e diffusori multipli in vetro. La grande articolazione del telaio compone una geometria complessa e radicale, sulla quale si innestano i corpi illuminanti in vetro decorato. Chiaro rimando alle sfarzose strutture architettoniche d'epoca Art Deco, il lampadario allude facilmente anche a stilemi precolombiani, rimarcati dalle evidenti spigolosità delle strutture metalliche.

Suspension lamp with metal structure and multiple glass diffusers. With its complex and radical geometric design, the pendant lamp Mya makes for a sublime addition to contemporary decors (with a retro twist). Inspired by Art Deco, it also alludes to pre-Columbian stylistic elements as the sharp-edged metal structure underlines.







1920

DESIGNED BY CHRISTIAN PICCOLO



1920

Sintetico e plastico nelle forme, il classico tubo metallico viene sagomato per ricordare il classico pattern dell'Art Decò. Il corpo centrale in metallo chiuso da un disco in PMMA sabbiato, direziona la luce in maniera uniforme. Nelle applique il diffusore può essere ruotato.

Synthetic and plastic in his form, the classic metal tube is shaped to recall the classic pattern of Art Deco. The metal central body closed by a sandblasted PMMA disc, direct the light uniformly. In the applique the diffuser can be rotated.



ARABESQUE

DESIGNED BY MM LAMPADARI WORKSHOP



ARABESQUE

La raffinatezza e sofisticatezza del vetro soffiato di Murano si sposano con gli ornamenti che trasmettono serenità e bellezza. È così che la serie di lampade Arabesque omaggia un'arte antica del bello declinandola in tutte le sue forme e dove protagonisti diventano i dettagli ed i riflessi che la luce trasmette.

The refinement and sophistication of Murano blown glass are combined with the ornaments that convey serenity and beauty. This is how the Arabesque series of lamps pays homage to an ancient art of beauty, declined in all its forms and where the protagonists become the details and reflections that light transmits.



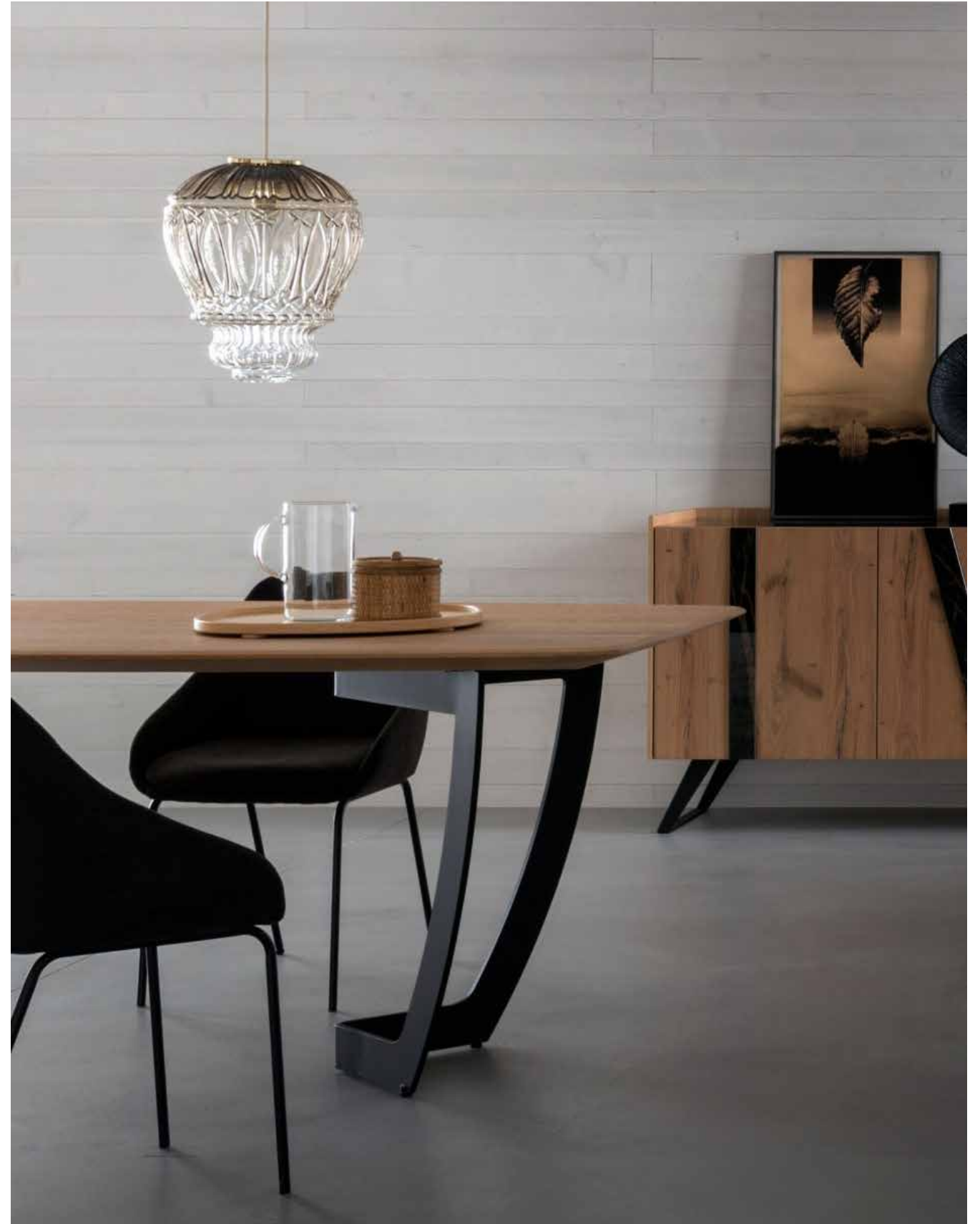



BUCCIA

DESIGNED BY MM LAMPADARI WORKSHOP



BUCCIA

Uno spiccato gusto
etnico sapientemente
rivisitato in chiave
moderna con metallo
lavorato a sbalzo e rifinito
in foglia oro.
Luce contemporanea
con un sapore
tradizionale.

*A strong ethnical look,
wisely revisitated
in modern key with
embossed work metal
and finished in gold leaf.
Contemporary light with a
traditional taste.*





CITY

DESIGNED BY ENRICO DE GIRARDI



CITY

La serie City vede delle lamiere di diversa dimensione assemblate a formare un cerchio o un quadro.

Le stesse lamiere sono lavorate a mano e decorate in foglia oro e foglia argento.

Per creare del movimento e giochi di luce diversi, la struttura viene rafforzata da inserti in vetro, anch'essi soffiati a mano.

Range City is made with metal sheets of different sizes, mounted to create a round or a square shape. The same sheets are hand worked and decorated in gold and silver leaf.

To create a movement and different games of light, the frame is enforced by glass inserts, blown by hand as well.



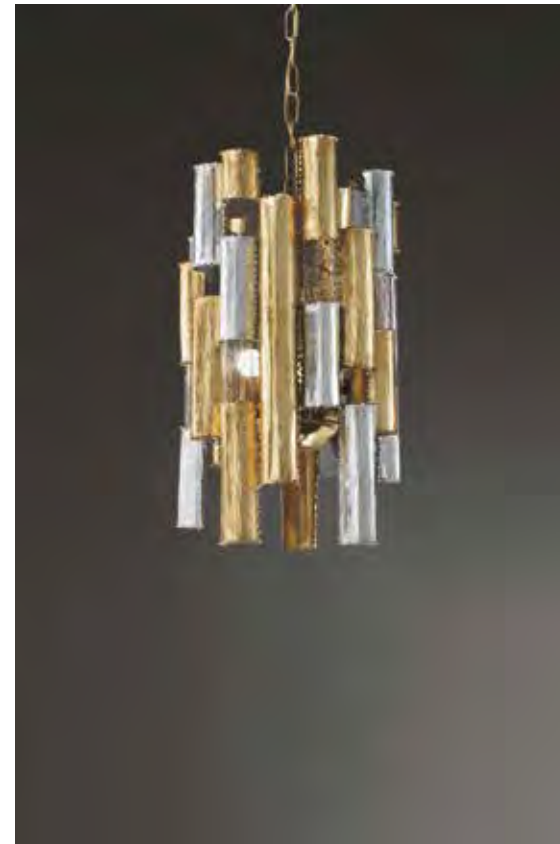

FILI

DESIGNED BY CHRISTIAN PICCOLO



FILI

Strizza l'occhio alla Op-Art questa famiglia di chandelier in tondini metallici leggeri che esaltano le righe trasformandole in elemento geometrico e decorativo pervaso di semplicità e freschezza. Ecco come Fili nelle sue diverse forme celebra l'effetto millerighe. Una illuminazione diretta che arriva dall'alto ne enfatizza le forme e la rende una lampada dal gusto senza tempo.

Wink at Op-Art this family of chandeliers in light metal rods that enhance the stripes, transforming them into a geometric and decorative element full of simplicity and freshness. This is how Fili, in its different forms, celebrates the stripes effect. Direct lighting from above emphasises its forms and makes it a lamp with a timeless taste.





GOCCIA

DESIGNED BY MM LAMPADARI WORKSHOP



GOCCIA

Sospensione ad una luce realizzata in vetro soffiato a mano secondo la tradizione dei maestri vetrai di Murano. La lampada è completata da un pendente in metallo che la rende longilinea e fluida.

Suspension with one light realized with hand-blown glass as per tradition of glass masters of Murano. The lamp is completed with a metal drop that makes it smooth and slender.





JACK

DESIGNED BY OLGA ENGEL



JACK

Lo stile neoclassico ed impero ispirano questa lampada che trasforma gli elementi decorativi in cristallo di forma geometrica ed allungata in un motivo ripetuto e circolare installato però in orizzontale ed in metallo arricchendo Jack di nuovi giochi di luce.

La sua struttura cinetica permette di spostare alcune delle sue parti, cambiandone così il suo diametro e conferendole un design in continua evoluzione.

The neoclassical and empire style inspires this lamp that transforms the decorative crystal elements of geometric and elongated shape into a repeated and circular motif installed horizontally and in metal, enriching Jack with new plays of light. Its kinetic structure allows moving some of its parts, thus changing its diameter and giving it a continuously evolving design.





MUSEO

DESIGNED BY MM LAMPADARI WORKSHOP



MUSEO

Lampade in foglia oro adibite ad una funzione precisa; da utilizzare sopra specchio sopra quadri; sono impreziosite all'estremità da cristalli Swaroski.

Lamps in gold leaf suitable for mirrors and pictures. They are made precious at the edges by Swaroski crystals.



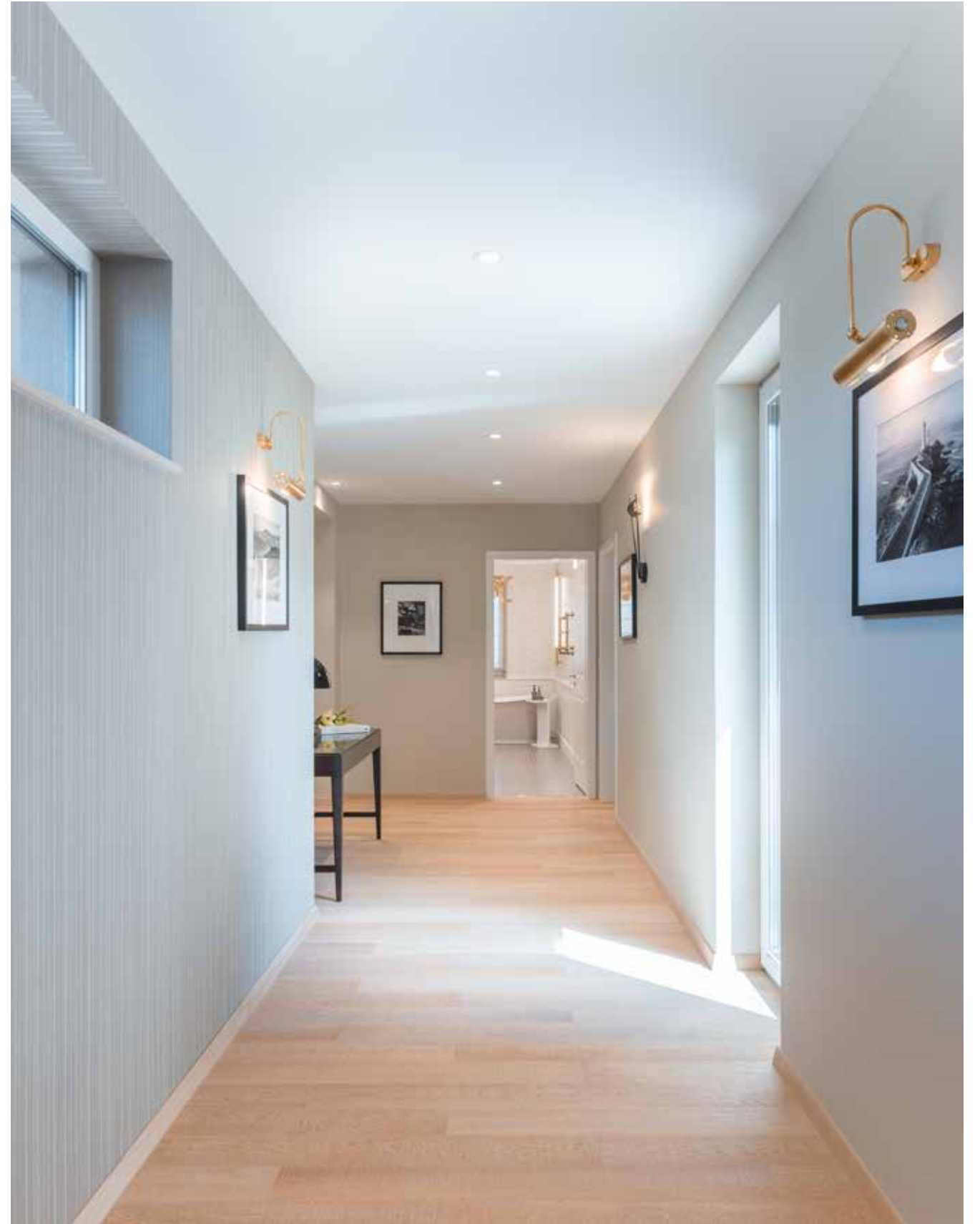

ORION

DESIGNED BY MM LAMPADARI WORKSHOP



ORION

Linee geometriche ed essenziali per la serie Orion con struttura impreziosita da passamaneria con motivi dorati.

Essential and geometric shapes for Orion series with a structure enriched by gold motif trimming





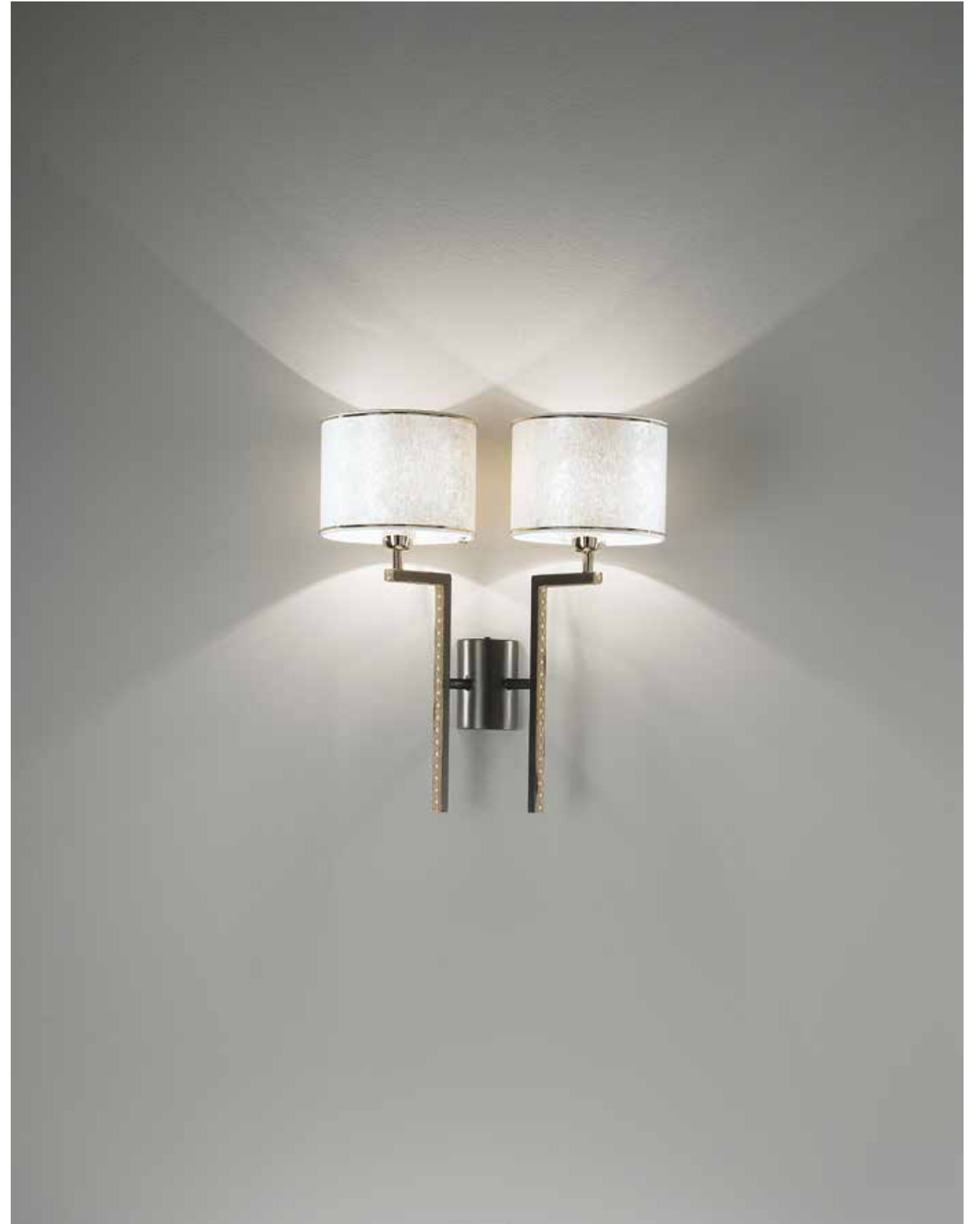

PERLA

DESIGNED BY CHRISTIAN PICCOLO



PERLA

Perla, lampada da parete dai tratti semplici ed al contempo distintivi. Due elementi in vetro uniti da un filo di metallo sono abbinabili nelle finiture bianco lucido, coprente ottonato o cemento per avere un effetto luce half oppure quarter moon.

Pearl, a wall lamp with simple but distinctive features. Two glass elements joined by a metal wire can be combined in glossy white, brass or concrete finishes to have a half moon or quarter moon light effect.



PETAL

DESIGNED BY STUDIO MAMMINI CANDIDO



PETAL

Lampada da parete,
dalla forma elegante
e dalle linee pulite
proposta in due misure.
Arreda ogni superficie
in cui viene installata
con libertà e fantasia,
come se fosse un vero
e proprio giardino. La
sua superficie materica
la rende viva e vivace,
alla stregua di un petalo
di fiore mosso dal vento
e conferisce dinamicità
e raffinatezza ad ogni
ambiente in cui si trova.

*Wall lamp, with an elegant
shape and clean lines,
available in two sizes. It
furnishes every surface
where it is installed with
freedom and imagination,
as if it were a real garden.
Its material surface makes
it alive and lively, like a
flower petal moved by the
wind and gives dynamism
and refinement to every
environment in which it is
found.*





PILL

DESIGNED BY MATTEO ZORZENONI



PILL

Questa serie di lampade è un omaggio alle antiche tecniche di lavorazione del vetro di Murano. La parte superiore con soffiatura su stampo e la parte inferiore con soffiatura a mano libera in gabbia metallica eseguita da Maestri vetrai. Connubio indissolubile tra la struttura in metallo e il vetro di Murano che sembrano abbracciarsi e quasi fondersi in un'unica entità e produrre un effetto etereo e di estrema eleganza.

Wink at Op-Art this family of chandeliers in light metal rods that enhance the stripes, transforming them into a geometric and decorative element full of simplicity and freshness. This is how Fili, in its different forms, celebrates the stripes effect. Direct lighting from above emphasises its forms and makes it a lamp with a timeless taste.





RAYS

DESIGNED BY MATTEO ZORZENONI



RAYS

Chiamata così per la rifrazione della luce donata dal vetro classico di Murano, Rays con la sua struttura in metallo circolare e top in vetro soffiato effetto balloton sostenuto da bracci radiali reinterpreta in chiave contemporanea lo stile essenziale e di ricerca del medioevo che faceva della luce il principale elemento di decorazione di interni.

Named after the refraction of light given by classic Murano glass, Rays, with its circular metal structure and top in blown glass with a balloton effect supported by radial arms, reinterprets in a contemporary way the essential style and research of the Middle Ages that made light the main element of interior decoration.





SASS

DESIGNED BY MM LAMPADARI WORKSHOP

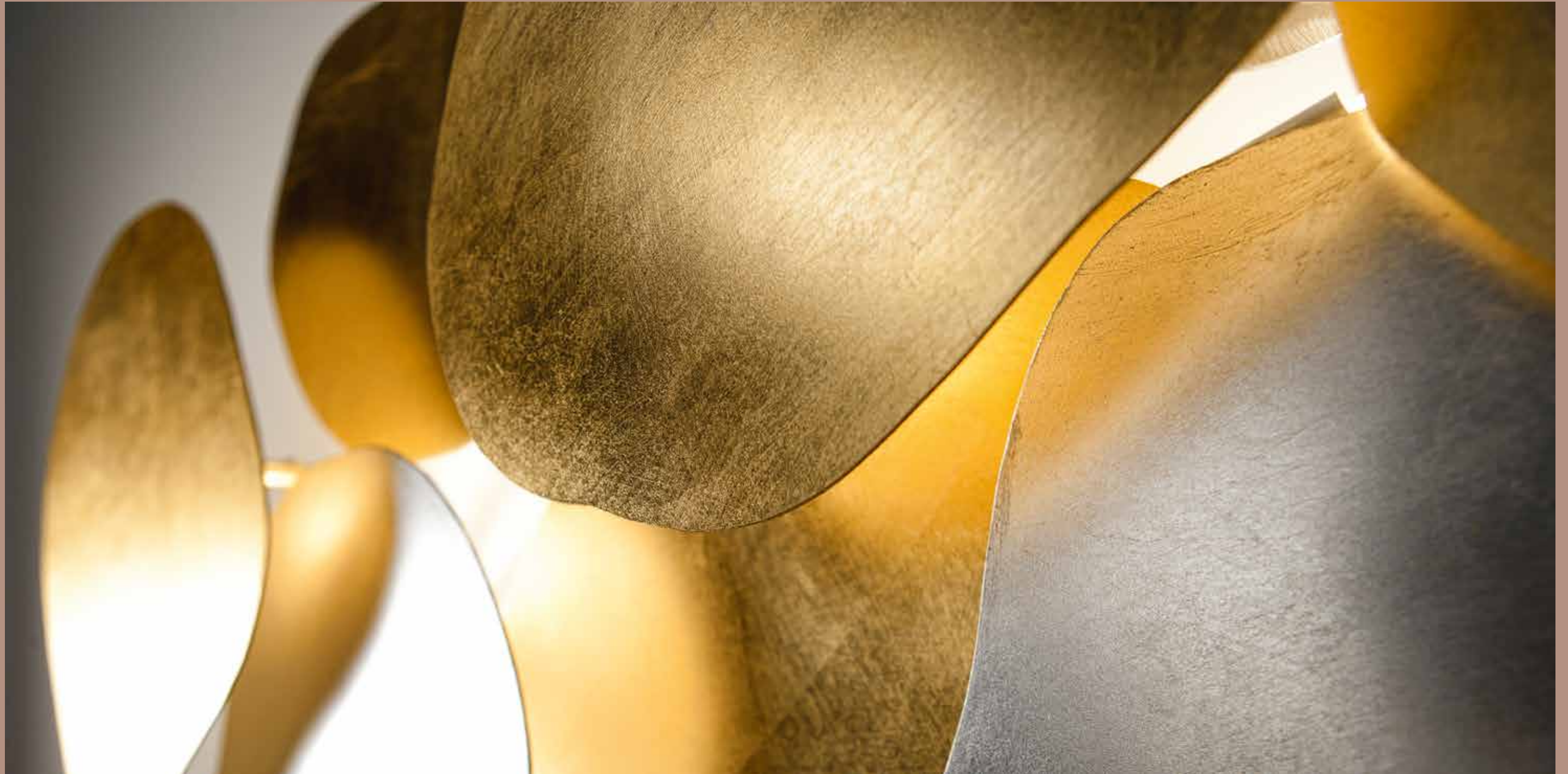

SASS

Lampade che si possono adattare sia a soffitto che a parete; sono realizzate con lamiere modulate in metallo, adagiate a creare quasi una scultura e decorate in foglia oro e foglia argento.

Lamps that can be used as ceiling or wall lamp; realized with metal sheet, positioned to create almost a sculpture, and finished in gold and silver leaf.





SKY

DESIGNED BY MM LAMPADARI WORKSHOP



SKY

Serie di lampade a parete e da terra, realizzate in metallo e decorate in finitura foglia oro e foglia argento.

La linearità della collezione sposa la ricercatezza delle finiture, creando un binomio moderno/classico perfetto per ogni tipo di ambiente.

Range of wall lamps and floorlamps made in metal and decorated in gold leaf and silver leaf. The linearity of the this collection, embrace the elegance of the finishes, creating a combination of modern classic, perfect for any kind of room.





1920

Lampada in Metallo e PMMA Lamp in Metal and PMMA

Struttura / Frame

- V2921
Oro Champagne verniciato
Champagne gold painted
- V2828
Canna di fucile verniciato
Gun metal grey painted
- V2945
Nickel
Nickel

Diffusore / Diffuser

- PMMA satinato
PMMA satin-finished

Illuminazione / light source

220 / 240V 1 x LED BOARD 8W 450lm 3000K
Incluso / Included



Art. 7388/A1

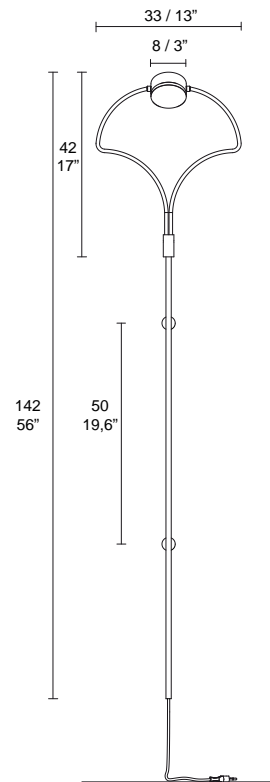

Marquise

AMANITA

Lampada vetro di Murano Murano glass lamp

Struttura / Frame

- V0216 ottone lucido

Diffusore / Diffuser

- cristallo rigato
grooved crystal
- bronzo rigato
grooved bronze

Illuminazione / light source

XXX

Lampadina non compresa / Bulb not included.

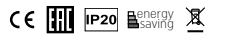

Art. 7425/L1

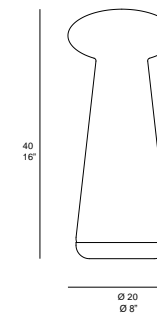



Marquise



ARABESQUE

Lampada in Metallo e PMMA
Lamp in Metal and PMMA

Struttura / Frame

-  V2553
Bianco lucido
Glossy White
-  V1607
Chromo lucido
Glossy chrome

Diffusore / Diffuser

-  Bianco lucido
Glossy white
-  Tortora sfumato
Fading taupe

Illuminazione / light source

-  20W E27 Led
220/240V

Lampadina non compresa / Bulb not included.

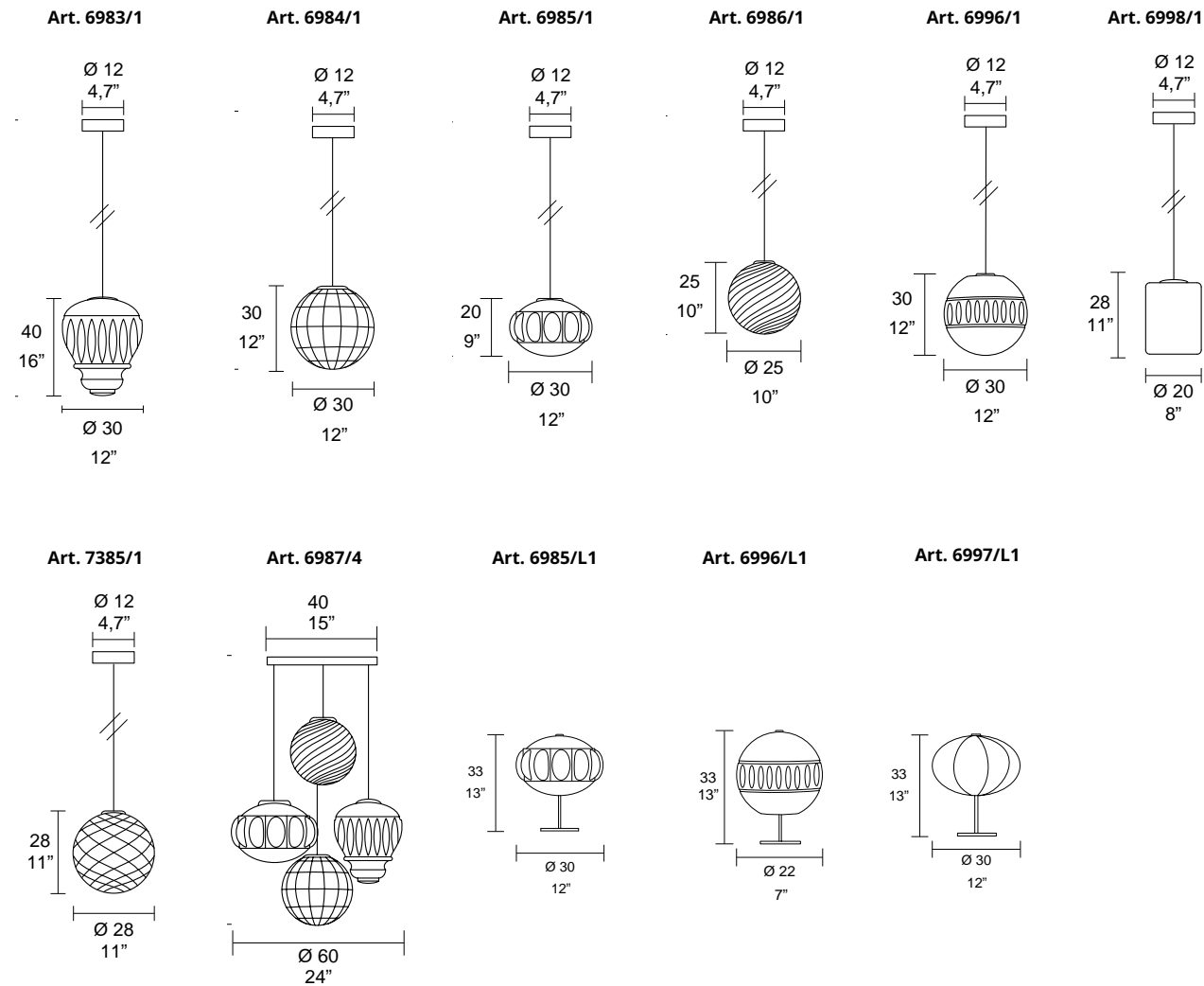

Marquise

BABILONIA

Lampada vetro di Murano
Murano glass lamp

Struttura / Frame

-  V 2833
Nickel nero
Black nickel

Diffusore / Diffuser

-  cristallo rigato
Bronzo rigato
striped crystal
Bronze striped

Illuminazione / light source

- 1 x LED BOARD 6,W 983lm 3000K
Incluso / Included

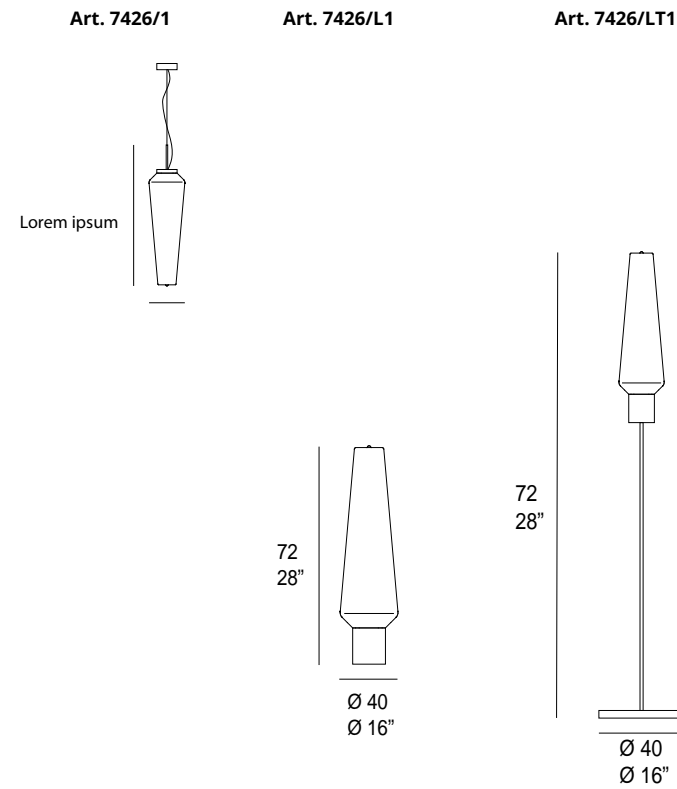
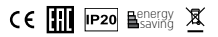

BUCCIA

Lampada in Metallo
Lamp in Metal

Struttura / Frame

V1669

Diffusore / Diffuser

metallo foglia oro
gold foil metal

Illuminazione / light source

10W E14 Led
220/240V

20W E27 Led
220/240V

5W G9 Led
220/240V

Lampadina non compresa / Bulb not included.



Art. 5958/3

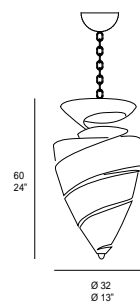

Art. 5958/1

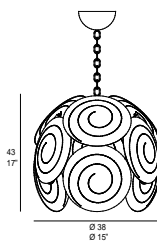

Art. 5958/P5

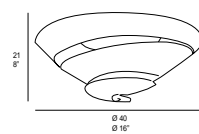

Art. 5958/P501

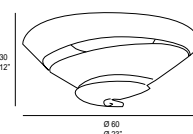

Art. 5958/A2

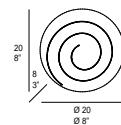

Art. 5958/L1

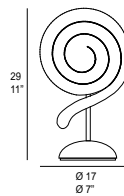

Marquise

CITY

Lampada in metallo ribrucciato
Burnished-metal lamp

Struttura / Frame

V1679

Diffusore / Diffuser

cristallo regolite
regolith crystal

Illuminazione / light source

10W E14 Led
220/240V

20W E27 Led
220/240V

5W G9 Led
220/240V

Lampadina non compresa / Bulb not included.

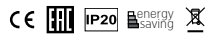

Art. 6579/42

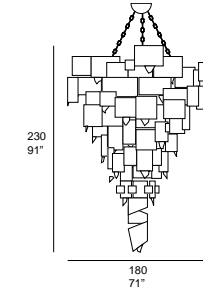

Art. 6580/28

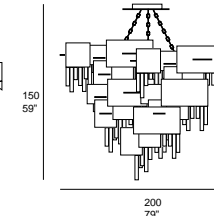

Art. 6579/4+1

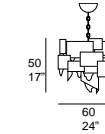

Art. 6580/6

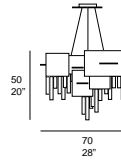

Art. 6580/4

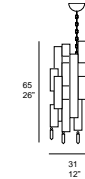

Art. 6579/A2



Art. 6580/A2



Art. 6580/A4

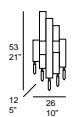

CURL

Lampada in Metallo
Lamp in Metal

Struttura / Frame



V0216

Diffusore / Diffuser

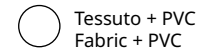

Tessuto + PVC
Fabric + PVC

Illuminazione / light source



10W E14 LED
220/240V

Lampadina non compresa / Bulb not included.



Art. 7432/5

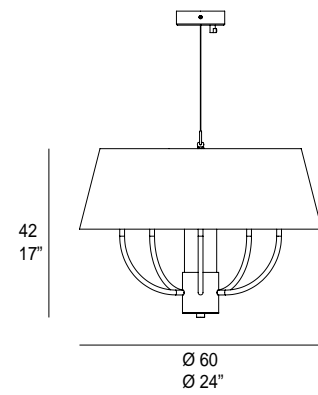

Marquise

CUSPIDE

Lampada vetro di Murano
Murano glass lamp

Struttura / Frame

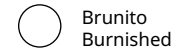

Brunito
Burnished

Diffusore / Diffuser

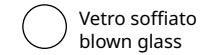

Vetro soffiato
blown glass

Illuminazione / light source



10W E14 Led
220/240V

Lampadina non compresa / Bulb not included.

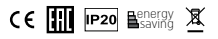

Art. 7413/5

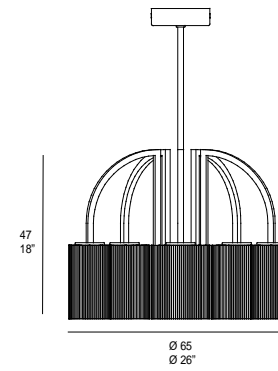

Art. 7413/A2

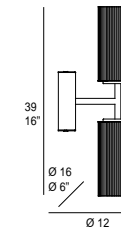

Art. 7413/A1

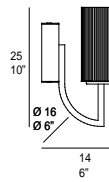

Art. 7413/L1

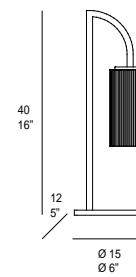

FILI

Lampada in Metallo
Lamp in Metal

Struttura / Frame

- V2950
Oro verniciato
Painted Gold
- V2721
Argento scuro
Dark silver
- V1607
Chromo lucido
Glossy chrome
- V2806
Rame lucido
Glossy copper

Diffusore / Diffuser

Illuminazione / light source



20W Gu10 Led 220/240V

Lampadina non compresa / Bulb not included.



Marquise

FONTAINE

Lampada vetro di Murano
Murano glass lamp

Struttura / Frame

- Nichel nero
black nichel

Diffusore / Diffuser

- Vetro soffiato cristallo e fumè sfumato
Crystal and shaded fumè blown glass

Illuminazione / light source



10W E14 Led 220/240V

Lampadina non compresa / Bulb not included.

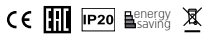

Art. D005/1 CIRCLE

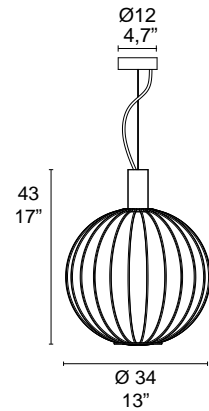

Art. D007/1 EXAGON

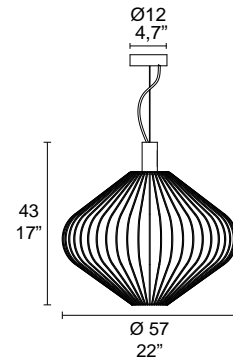

Art. D008/1 TRIANGLE

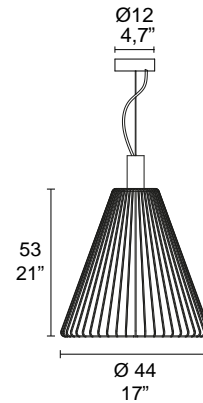

Art. D049/1 RHOMBUS

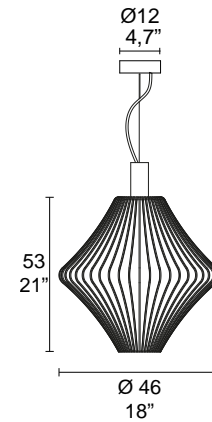

Art. 7430/6

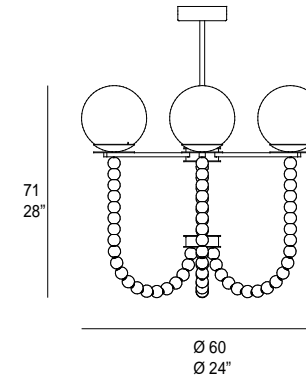

GOCCIA

Lampada in Metallo Lamp in Metal

Struttura / Frame

V2721
Argento scuro
Dark silver

Diffusore / Diffuser

vetro murano decorato
fumè
murano glass fumè
decorated

vetro murano decorato
turquoise- murano
glass turquoise deco-
rated

vetro murano decorato
rosa- murano glass
pink decorated

Illuminazione / light source



20W E27 Led
220/240V

Lampadina non compresa / Bulb not included.



Art. 7049/1

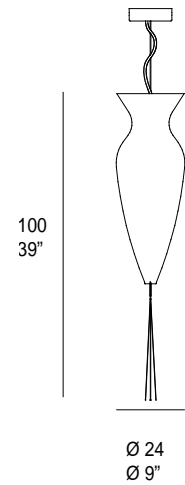

Art. 7049/3

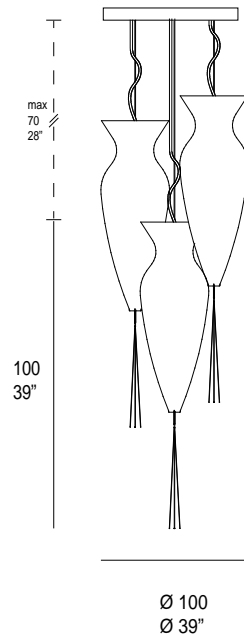

Marquise

JACK

Lampada vetro di Murano Murano glass lamp

Struttura / Frame

V2907
Bianco opaco
Matt White

V0216
Ottone lucido
Glossy brass

V2934
Oro spazzolato
Brushed gold

Diffusore / Diffuser

PMMA opale
Ice white

Illuminazione / light source

3 x 20w 300k
220/240V

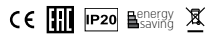

Art. 7380/3

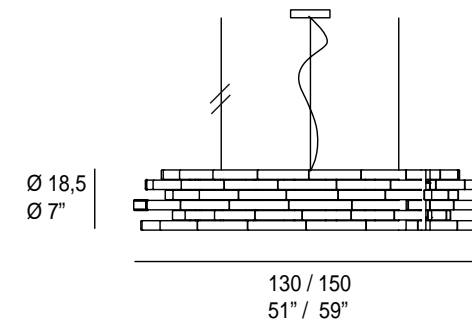

MUSEO

Lampada in metallo, verniciato o trattamento galvanico, e vetro murano balloton
Metal lamp, painted or galvanic treatment, and murano balloton glass

Struttura / Frame **Diffusore / Diffuser** **Illuminazione / light source**

V1022

con cristalli e bordi fiammati
with crystals and flamed edges



Lampadina non compresa / Bulb not included.



Art. 6883/A2

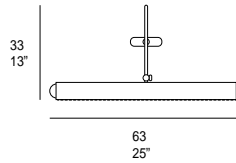

Art. 6883/A1

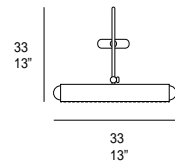

Art. 7435/A2

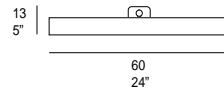

Art. 7435/A1

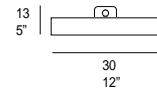

Marquise

MYA

Lampada in metallo e vetro Murano incamiciato
Metal and "Incamiciato" Murano glass lamp

Struttura / Frame **Diffusore / Diffuser** **Illuminazione / light source**

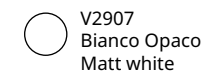

V2907
Bianco Opaco
Matt white

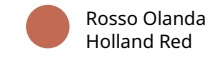

Rosso Olanda
Holland Red

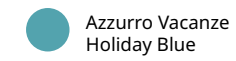

Azzurro Vacanze
Holiday Blue



Bianco latte
Milky White

8 x max 10W E14 220/240V
16 x max 10W E14 220/240V

8 x max 10W E12 100/110V
16 x max 10W E12 100/110V

Lampadina non compresa / Bulb not included.

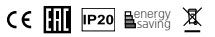

Art. 7415/8

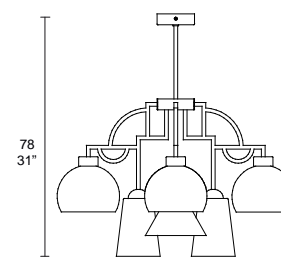

Art. 7415/16

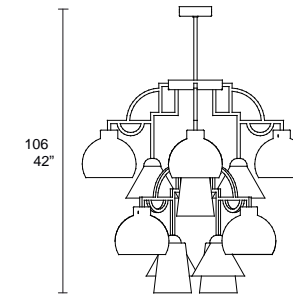

Art. 7415/1

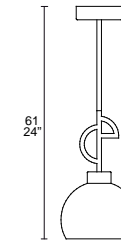

Art. 7415/3

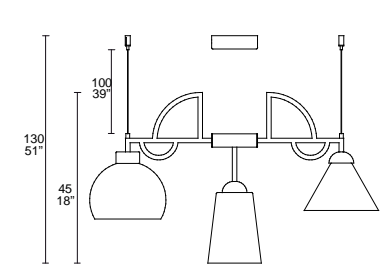

Art. 7415/A1

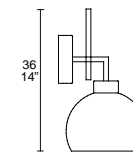

OPUS

Lampada in metallo, verniciato o trattamento galvanico, e vetro murano balloton
Metal lamp, painted or galvanic treatment, and murano balloton glass

Struttura / Frame	Diffusore / Diffuser	Illuminazione / light source
V2805	Vetro soffiato blown glass	 20W E27 Led 220/240V

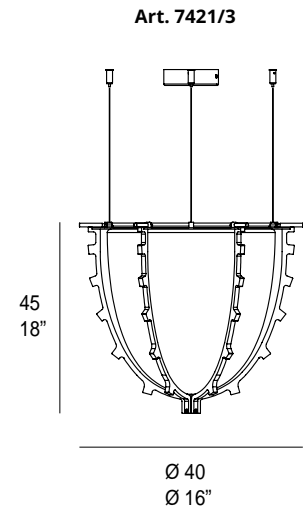

Lampadina non compresa / Bulb not included.



Marquise

ORION

Lampada in metallo e vetro Murano incamiciato
Metal and "Incamiciato" Murano glass lamp





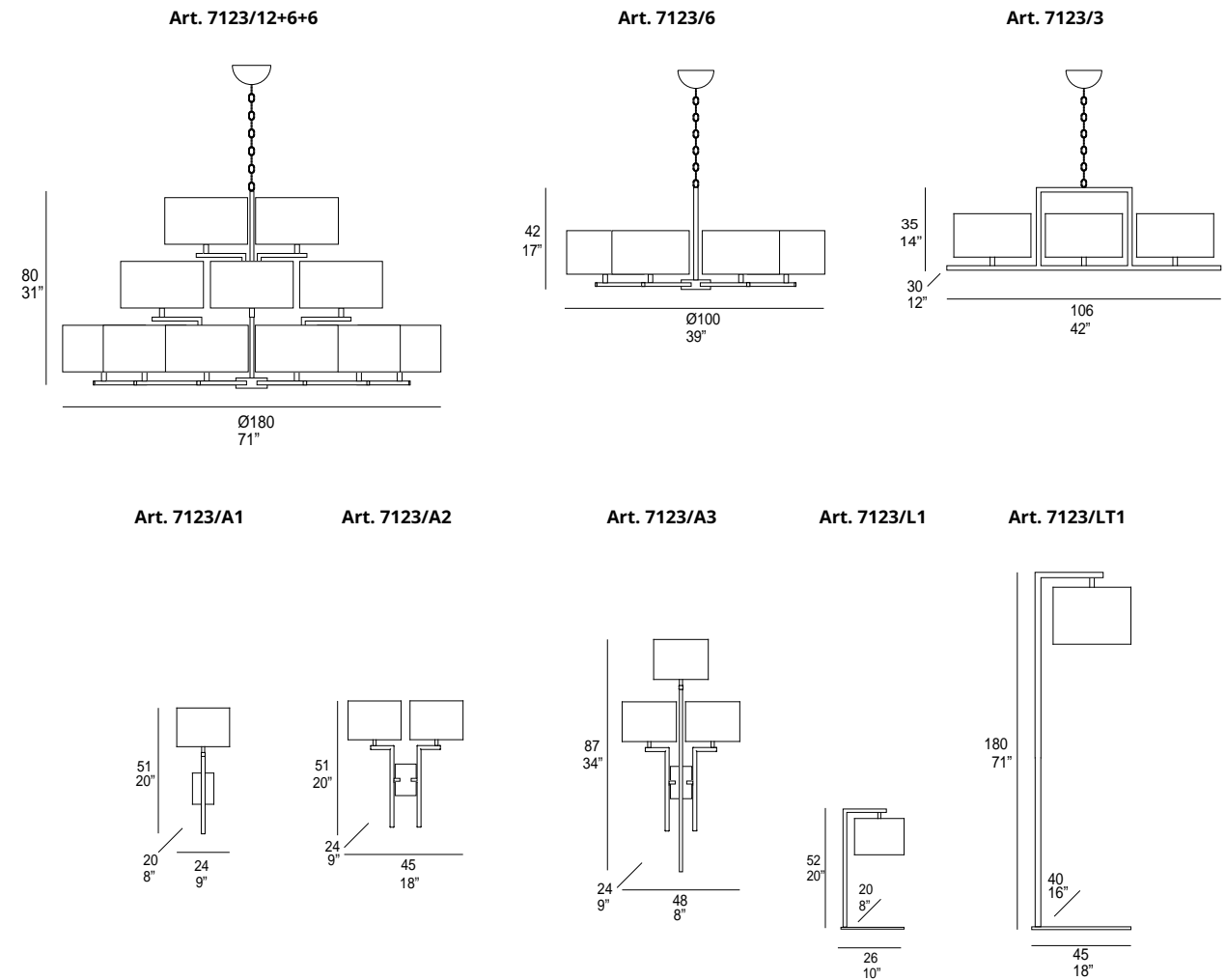
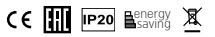





Struttura / Frame	Diffusore / Diffuser	Illuminazione / light source
 V2774	paralume tessuto fabric lampshade	 20W E27 Led 220/240V

Lampadina non compresa / Bulb not included.



PERLA

Lampada in metallo, verniciato o trattamento galvanico, e vetro
Metal lamp, painted or galvanic treatment, and glass

Struttura / Frame	Diffusore / Diffuser	Illuminazione / light source
 V2907 Bianco Opaco Matt white	 Vetro bianco White glass	1 x LED BOARD 8W 220-240V 800lm 3000K 220/240V
 V2902 Ottone ossidato Burnished Brass	 Vetro bianco White glass	
 V2902 Ottone ossidato Burnished Brass	 Vetro bianco White glass  Ottone ossidato Burnished Brass	
 V2905 Ottone ossidato Burnished Brass	 Vetro bianco White glass  Cemento Concrete	

Art. 7387/A1

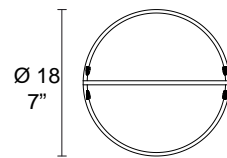





Marquise



PETAL

Lampada in metallo
Metal lamp

Struttura / Frame	Diffusore / Diffuser	Illuminazione / light source
 V2901 Ferro decapato Pickled iron (struttura esterna)	 PMMA	STRIP LED 20W 3000K 1410lm 110/240V LED STAR 1W 3000K 120lm 110/240V
 Acciaio anticato Antiqued steel (parte interna)		
 V2903 Ottone ossidato Burnished brass (struttura esterna)		
 Oro anticato Antiqued gold (parte interna)		

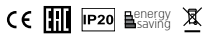

Art. 7377/A1 S

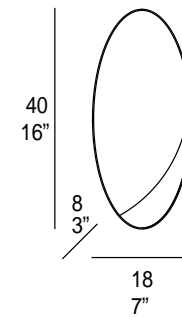

Art. 7377/A1 L

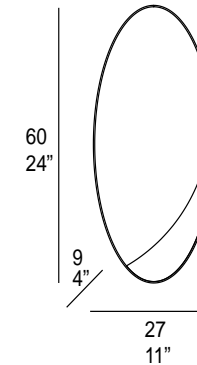

PILL

Lampada in metallo, verniciato o trattamento galvanico, e vetro murano
Metal lamp, painted or galvanic treatment, and murano glass

Struttura / Frame

- V0197
Oro 24K
Gold 24K

Diffusore / Diffuser

- Vetro fumé
Fumé glass
- Vetro ambrato
Amber glass

Illuminazione / light source

- 20W E27 Led
220/240V

Lampadina non compresa / Bulb not included.



Art. 7237/A1

Art. 7237/L1

Art. 7237/LT1

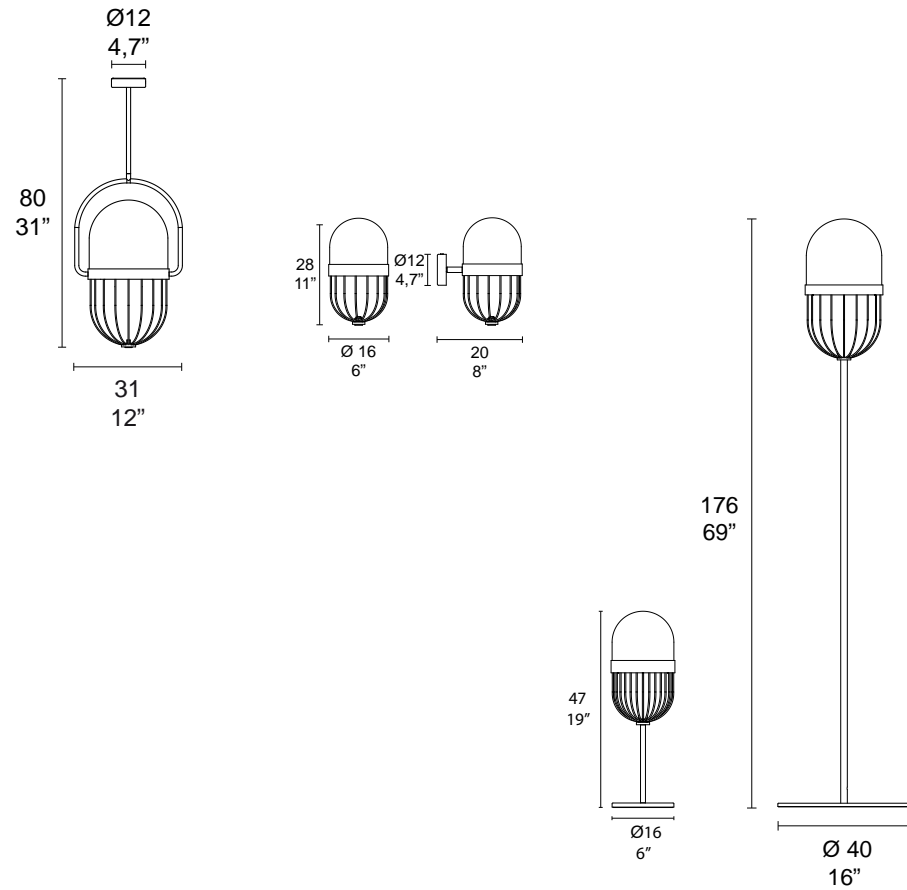

Marquise

RAYS

Lampada in metallo, verniciato o trattamento galvanico, e vetro murano balloton
Metal lamp, painted or galvanic treatment, and murano balloton glass

Struttura / Frame

- V0199
Nero opaco
Matt black
- V2805
Ottone satinato
Satin brass

Diffusore / Diffuser

- Cristallo balloton
Crystal balloton

Illuminazione / light source

- 15W E14Led
220/240V

Lampadina non compresa / Bulb not included.

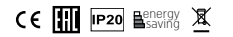

Art. 7209/P3

Art. 7209/L3

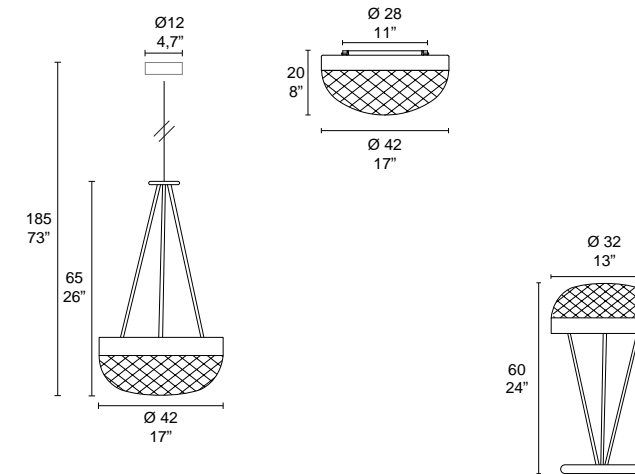

SASS

Lampada in metallo, verniciato o trattamento galvanico, e vetro murano balloton
Metal lamp, painted or galvanic treatment, and murano balloton glass

Struttura / Frame

V2907
Bianco opaco
Matt white

Diffusore / Diffuser

Illuminazione / light source

3 x 4,5W 1368lm
3000K 110/240V

Lampadina non compresa / Bulb not included.

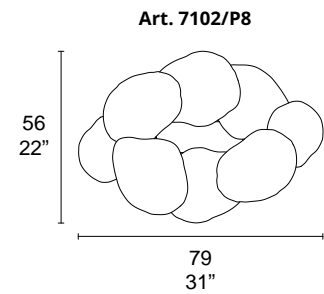
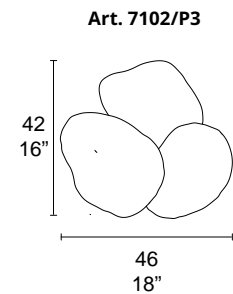

Marquise

SKY

Lampada in metallo verniciato
Metal lamp painted

Struttura / Frame

V2907
Bianco opaco
Matt white

Diffusore / Diffuser

Illuminazione / light source

20W E27 Led
220/240V

Lampadina non compresa / Bulb not included.

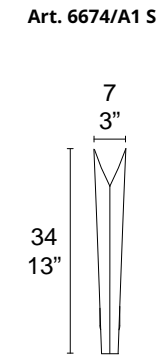
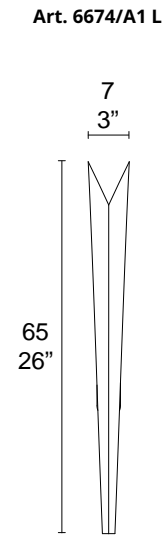
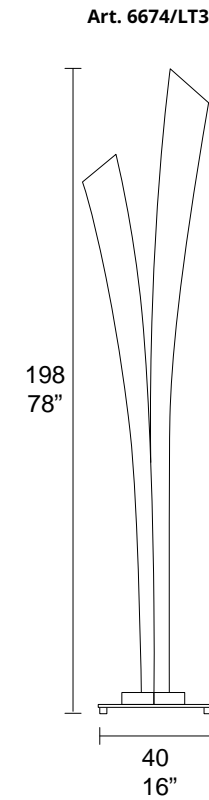
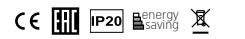

TRIGON

Lampada in metallo, verniciato o trattamento galvanico, e vetro murano
Metal lamp, painted or galvanic treatment, and murano glass

Struttura / Frame	Diffusore / Diffuser	Illuminazione / light source
	vetro soffiato Glass	LEAD BOARD 10W 120/240 128lm 3000K

Lampadina non compresa / Bulb not included.



Marquise

TUMBLER

Lampada in metallo verniciato
Metal lamp painted

Struttura / Frame	Diffusore / Diffuser	Illuminazione / light source
	Vetro soffiato cristallo inciso a mano_ Crystal blown glass hand graven	20W E27 Led 220/240V 15W E14 Led 220/240V

Lampadina non compresa / Bulb not included.

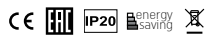

Art. 7424/1

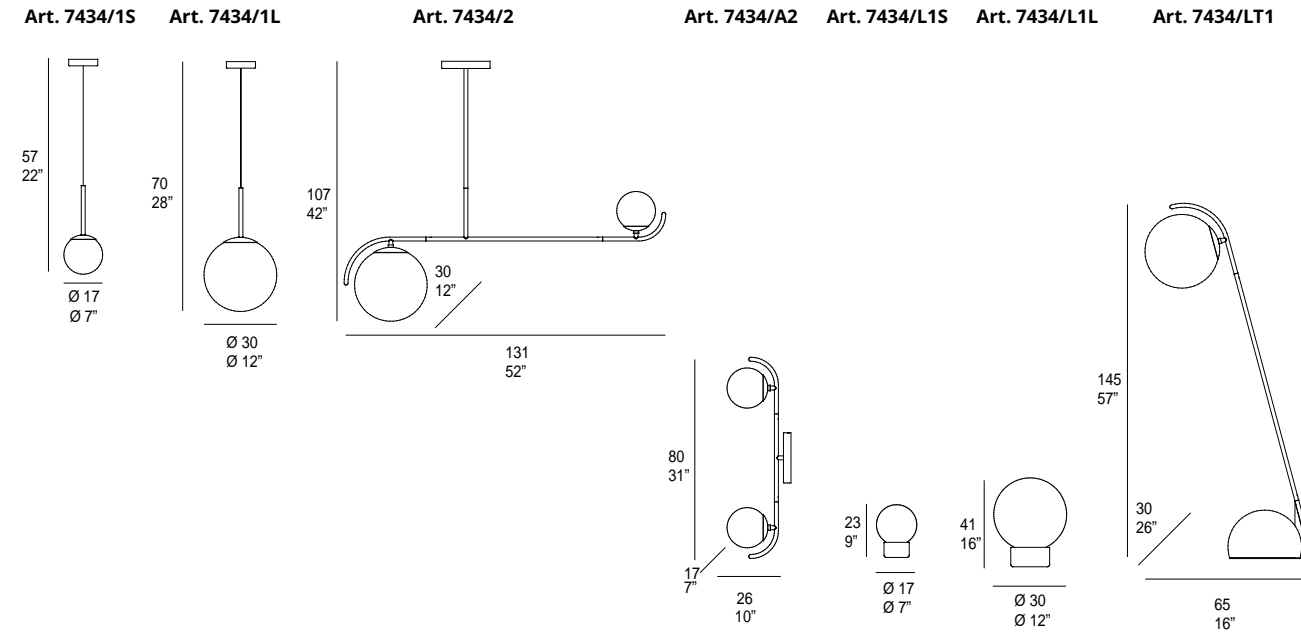
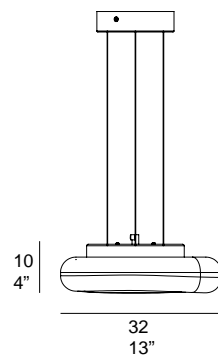

CONDIZIONI GENERALI DI VENDITA

1. Conclusione del contratto

1. Il contratto si intende concluso con la sottoscrizione da parte del Compratore dell'offerta di vendita inviata da MM Lampadari.
2. I contatti fra le parti, sia verbali che scritti, che precedono l'emissione dell'offerta si inseriscono nell'ambito delle trattative precontrattuali e non costituiscono conclusione del contratto, che potrà avvenire nelle sole modalità previste al primo comma.
3. MM Lampadari si impegna a mantenere ferma l'offerta di vendita per 60 giorni successivi alla data di invio, salvo sia diversamente riportato nell'offerta medesima.
4. Ogni modifica delle presenti condizioni dovrà avvenire per iscritto.

2. Agenti e ausiliari del commercio

1. Il Compratore prende atto e riconosce che gli agenti o gli ausiliari del commercio in genere di MM Lampadari, non hanno il potere di vincolare in alcun modo MM Lampadari.
2. Il Compratore non potrà invocare, per l'attribuzione di diritti non conformi a quanto esposto nelle presenti condizioni e nell'offerta di vendita, eventuali deroghe o tolleranze che non risultino espressamente approvate da MM Lampadari.

3. Consegna

1. Il Compratore prende atto che i termini e le indicazioni di consegna indicati nell'offerta di vendita sono meramente indicativi. La data di consegna non può considerarsi termine essenziale.
2. La merce viene prodotta da MM Lampadari in conformità alle disposizioni normative vigenti, in quanto applicabili.
3. La merce viene consegnata da MM Lampadari con il foglio istruzioni. Il Compratore che distribuisce la merce deve sempre mettere in circolazione la merce con il foglio istruzioni. In difetto di quanto appena previsto, il Compratore risponderà nei confronti di MM Lampadari di tutti i danni diretti ed indiretti che la stessa abbia in conseguenza a patirne.
4. Salvo venga diversamente pattuito fra le parti, la resa della merce si intende ex works.
5. A prescindere dai termini di resa pattuiti, il Compratore prende atto e accetta che la merce viaggia a proprio esclusivo rischio. L'obbligo di consegna della merce da parte di MM Lampadari si ritiene in ogni caso adempiuto nel momento in cui MM Lampadari consegna la merce al vettore o allo spedizioniere. I rischi passano al Compratore al più tardi con la consegna al primo trasportatore o, qualora il Compratore non ritiri la merce a tempo debito, a partire dal momento in cui la merce viene messa a sua disposizione ed in cui commette un'inadempienza al contratto non prendendola in consegna.
6. Il Compratore riconosce di non aver facoltà né di rifiutare la merce consegnata né di rendere la stessa, se non nel rispetto di quanto previsto al successivo articolo 5.
7. Il rifiuto della merce da parte del Compratore e/o la restituzione della stessa al di fuori del meccanismo indicato nell'articolo 5, costituirà per MM Lampadari motivo di risoluzione immediata del contratto ex art. 1456 c.c., con facoltà per la stessa di trattenere le somme già incassate a titolo di penale. Detta facoltà non viene meno in caso di emissione da parte di MM Lampadari della nota di credito o di documento equipollente, in conseguenza del rifiuto della merce e/o della resa della stessa.
8. Salvo il caso di dolo o colpa grave di MM Lampadari, è, in ogni caso, espressamente escluso qualsiasi risarcimento del danno per mancata o ritardata consegna della merce in favore del Compratore.

4. Pagamento

1. Il Compratore si obbliga ad effettuare i pagamenti dovuti con le modalità e nei termini indicati nell'offerta di vendita.
2. MM Lampadari avrà la facoltà, qualora non riceva il pagamento in base alle modalità indicate nell'offerta di vendita, di considerare il Compratore inadempiente e di risolvere ex art. 1456 c.c. il contratto, trattando a titolo di penale convenzionale l'importo ricevuto a titolo di acconto, salvo il maggior danno.
3. Salvo patto contrario, i prezzi si intendono per la merce imballata secondo gli usi del settore, essendo inteso che ogni spesa o onere sarà a carico del Compratore. Le spese di trasporto sono a carico del Compratore, salvo sia diversamente indicato nell'offerta di vendita.
4. Il Compratore non è autorizzato ad effettuare alcuna deduzione dal prezzo pattuito, neppure in caso di pretesi difetti di non conformità della merce, se non previo accordo scritto con MM Lampadari.

5. Reclami e reso merce

1. Il Compratore si impegna ad effettuare un diligente controllo della merce al momento del suo ricevimento. Eventuali reclami sulla merce consegnata dovranno essere denunciati direttamente per iscritto a MM Lampadari entro i termini di legge (otto giorni dal ricevimento della merce in caso di vizi apparenti, otto giorni dalla scoperta in caso di vizi occulti, intendendosi per tali vizi non individuabili mediante il diligente controllo cui il Compratore è tenuto al momento del ricevimento della merce) e dovranno specificare con precisione il vizio e/o difetto riscontrato e la merce a cui si riferiscono. In ogni caso, fermi restando i termini di denuncia suddetti, la garanzia legale fornita da MM Lampadari si prescrive in un anno dalla consegna della merce. Il Compratore prende atto che non saranno ritenute valide dichiarazioni e/o reclami fatti all'agente o altro ausiliario del commercio.
2. Il Compratore prende atto e riconosce che: i) non costituiscono vizi e/o difetti le eventuali mancanze di uniformità nelle tonalità e/o nel disegno delle decorazioni, essendo queste caratteristiche delle lavorazioni a mano dei prodotti; ii) MM Lampadari non risponderà di danni determinati da errato montaggio o improprio utilizzo della merce da parte del Compratore e/o in caso di mancata osservanza da parte di questi del foglio istruzioni; iii) a pena di decadenza dalla garanzia per vizi e/o difetti, la merce oggetto di reclamo dovrà essere adeguatamente custodita dal Compratore in modo da non comprometterne le caratteristiche estetiche e funzionali (a titolo esplicativo la merce dovrà essere custodita al riparo da intemperie e condizioni atmosferiche avverse); iv) MM Lampadari non sarà ritenuta responsabile del normale consumo dei materiali (quali sorgenti luminose, guarnizioni, batterie); v) MM Lampadari non sarà ritenuta responsabile qualora il non funzionamento della merce consegnata dipenda dall'uso di materiali non originali o inadeguati (quali l'utilizzo lampadine non adatte in base alla scheda tecnica fornita); vi) MM Lampadari è esente da responsabilità qualora l'impianto elettrico, dove sono installati i prodotti, non permetta il funzionamento del lampadario fornito o danneggi le sorgenti luminose integrate fornite.
3. Il Compratore rinuncia espressamente al diritto di regresso nei confronti di MM Lampadari anche ai sensi dell'art. 134 D. Lgi 206/2005, ferma restando la responsabilità di MM Lampadari in caso di prodotto difettoso ex art. 115 e ss D. Lgi 206/2005.
4. Il reso della merce è subordinato alla preventiva denuncia di vizi e/o difetti secondo le modalità stabilite al successivo comma e all'autorizzazione scritta di MM Lampadari al reso.
5. Qualora MM Lampadari autorizzi il Compratore a rendere la merce, il controllo della merce medesima verrà effettuato presso MM Lampadari, salva diversa indicazione di questa. Qualora MM Lampadari verifichi l'esistenza di vizi e/o difetti denunciati della merce, il Compratore avrà diritto, a scelta insindacabile di MM Lampadari, alla sostituzione della merce difettosa o al rimborso del prezzo pattuito per la vendita della merce difettosa. Il Compratore rinuncia espressamente alla richiesta nei confronti di MM Lampadari di qualsivoglia risarcimento del danno o indennità. La merce resa viaggia a spese e a rischio del Compratore.
6. E' inteso che eventuali reclami sulla merce non danno diritto al Compratore di sospendere o comunque ritardare i pagamenti della merce oggetto di contestazione, né, tanto meno, di altre forniture.

6. Autotutela

1. Qualora MM Lampadari abbia motivo di temere che il Compratore non possa o non intenda pagare la merce alla data pattuita, potrà: i) sospendere la consegna della merce; ii) subordinare la consegna della merce all'integrale pagamento di quanto dovuto o all'osservanza di termini e modalità di pagamento diversi rispetto a quelli indicati nell'offerta di vendita; iii) subordinare la consegna della merce alla prestazione di garanzie di pagamento.
2. In caso di mancati, ritardati pagamenti anche relativi a diverse forniture, MM Lampadari potrà modificare unilateralmente i termini e le modalità di pagamento anche delle altre forniture e/o sospendere l'esecuzione fino all'ottenimento del pagamento e/o di adeguate garanzie di pagamento.

7. Forza Maggiore

1. Qualora si verifichi un evento imprevedibile fuori dal controllo delle Parti e che renda l'esecuzione del singolo contratto di vendita impossibile (quali a titolo esemplificativo e non esaustivo, terremoti e altre calamità naturali di grave portata, epidemie, emergenze sanitarie, scioperi, guerra, dichiarata o non, sommosse o rivoluzioni, boicottaggi, embarghi, eventi riferibili anche riferibili agli eventuali fornitori di MM Lampadari), le Parti potranno sospendere l'esecuzione. 2. Ciascuna parte dovrà comunque informare prontamente l'altra dell'insorgere della circostanza di forza maggiore e prendere tutti i provvedimenti atti a limitarne gli effetti, limitatamente a quanto in suo potere.

8. Legge applicabile

1. Il presente contratto è regolato dalla legge italiana.
2. Qualsiasi riferimento a termini commerciali è da intendersi come richiamo agli Incoterms della Camera di Commercio Internazionale, nel testo in vigore alla data di stipulazione del contratto.

9. Foro competente

1. Per ogni controversia nascente dalla validità, interpretazione o esecuzione del contratto sarà esclusivamente competente il Giudice del luogo in cui ha sede MM Lampadari.

GENERAL SALES TERMS

1. Entering into the Contract

- The Contract is entered into upon the Purchaser signing the Offer of Sale sent by MM Lampadari.
- Contacts made between the Parties, both verbal and written, that precede an Offer being issued form part of the pre-contractual negotiations and do not constitute the conclusion of the Contract, which may happen only in the ways established in the first clause.
- MM Lampadari undertakes to maintain the validity of the Offer of Sale for 60 days from the sending date, unless otherwise stated in the Offer itself.
- Any amendment of these conditions shall be made in writing.

2. Sales Agents and Auxiliaries

- The Purchaser acknowledges and accepts that MM Lampadari agents and trade auxiliaries in general do not have the power to bind MM Lampadari in any way whatsoever.
- The Purchaser shall not be entitled to invoke, for the attribution of rights that do not comply with these conditions or the Offer of Sale, any derogations or tolerances that are not expressly approved by MM Lampadari.

3. Delivery

- The Purchaser acknowledges that the delivery terms and instructions stated in the Offer of Sale are purely indicative. The delivery date cannot be considered a binding deadline.
- The goods are produced by MM Lampadari in compliance with the regulations in force, as applicable.
- The goods are delivered by MM Lampadari accompanied by an instruction sheet. The Purchaser distributing the goods shall also dispense the goods with the aforementioned instructions sheet. Failing to observe the above, the Purchaser will be liable towards MM Lampadari for all direct and indirect damages that may be suffered as a result.
- Unless otherwise established between the Parties, the goods shall be delivered ex works.
- Regardless of the agreed upon terms of return, the Purchaser acknowledges and accepts that the goods travel at the Purchaser's own exclusive risk. MM Lampadari's obligation to deliver the goods is, in any case, understood as being fulfilled upon MM Lampadari handing over the goods to the courier or shipper. The risks pass to the Purchaser, at the latest, with delivery to the first transporter or, if the Purchaser does not collect the items in good time, from the moment at which the goods are made available to the Purchaser or upon the Purchaser breaching the Contract by not taking delivery of the goods.
- The Purchaser accepts that the same has no right neither to refuse the goods delivered nor to return the same, if not in compliance with that set forth in Article 5 below.
- The rejection of the goods by the Purchaser and/or their return outside the mechanism indicated in Article 5 shall constitute grounds for immediate termination of the Contract for MM Lampadari, with the right for the same to retain the sums already collected by way of penalty. This right shall not lapse if MM Lampadari issues a Credit Note or equivalent document as a consequence of the rejection of the goods and/or their return.
- Except in the case of wilful misconduct or gross negligence by MM Lampadari, any compensation for damage due to missed or late delivery of the goods in favour of the Purchaser is, in any case, expressly excluded.

4. Payment

- The Purchaser undertakes to make the payments due with the means and under the terms indicated in the Offer of Sale.
- If payment is not received in accordance with the terms indicated in the Offer of Sale, MM Lampadari shall have the right to consider the Purchaser in default and to terminate the Contract pursuant to Article 1456 of the Italian Civil Code, withholding the amount received as a payment on account by way of conventional penalty, without prejudice to any greater damages.
- Unless where otherwise agreed, the prices are understood as being for packaged goods based on industry uses, it being tacit that any expense or charge will be borne by the Purchaser. Transport costs shall be paid by the Purchaser, unless otherwise indicated in the Offer of Sale.
- The Purchaser is not authorised to make any deduction to the established price, not even in the event that alleged non-conformities are claimed, unless otherwise agreed upon in writing with MM Lampadari.

5. Complaints

- Any claims relative to any apparent non-conformity, taken as meaning the presence of faults in the external characteristics of the goods, shall be reported by the Purchaser – at the risk of forfeiture – in writing to MM Lampadari within 8 (eight) days from receiving the same. The Purchaser commits to the goods being submitted to suitable, diligent checks upon receipt.
- Any claims relative to hidden non-conformities, taken to mean faults that are not immediately noticeable via a suitable, diligent check which the Purchaser is to perform upon receipt of the goods, shall be reported by the Purchaser – at the risk of forfeiture – in writing to MM Lampadari within 8 (eight) days from such non-conformity being detected and, in any case, no later than twelve months from the same being delivered.
- The Purchaser acknowledges and recognises that: i) any lack of uniformity in the shades and/or design of the decorations does not constitute a defect and/or fault, as these are characteristics of the hand-made workmanship of the products; ii) MM Lampadari shall not be liable for any damages caused as a result of incorrect assembly or improper use of the goods by the Purchaser and/or in the event of failure by the latter to comply with the instruction sheet; iii) under penalty of forfeiture of the warranty for defects and/or faults, the goods subject to any claim shall be properly stored by the Purchaser in such a way as not to compromise their aesthetic or functional characteristics (by way of mere example, the goods are to be stored protected from inclement weather and adverse atmospheric conditions); iv) MM Lampadari shall not be held responsible for the normal consumption of materials (such as light sources, seals, batteries); v) MM Lampadari shall not be held liable if the non-functioning of the goods delivered is due to the use of non-original or inappropriate materials (such as the use of light bulbs that are not suitable according to the technical data sheet supplied); vi) MM Lampadari shall not be held liable if the electrical system of the sites where the products are installed does not permit operation of or causes damage to the integrated light sources supplied.
- Any claim shall clearly specify the non-conformity detected and the goods to which the same refers. Returning goods for the purposes of checking the same is, in any case, subject to the non-conformity having been reported in advance, in compliance with that set forth in this Article and upon the written authorisation of MM Lampadari for the return to be effectuated. If MM Lampadari authorises the Purchaser to return the goods, the goods will be checked by MM Lampadari at its facility, save any other provisions being established. If, after carrying out its check, MM Lampadari confirms the existence of the non-conformity, that set in the following Article shall apply. Returned goods travel at the Purchaser's expense and risk.
- The period of limitation indicated in this Article is considered as being reasonable by both Parties.

6. Warranty on the goods

- MM Lampadari commits to remedying any non-conformity in the goods that is attributable to the same and which is confirmed within twelve months from the goods being delivered to the Purchaser, provided that such a non-conformity has been promptly reported in compliance with that set out in Article 5 above. A period of twelve months is agreed between the Parties in express derogation of that set forth in Article 39 of the Vienna Convention.
- In the case set out in the preceding clause, MM Lampadari will remedy any non-conformity, at its sole discretion providing for the replacement or repair of the goods (or parts thereof) found to be defective. If replacement or repair is not possible, MM Lampadari may reimburse the Purchaser the price paid for the goods found to be defective.
- The Purchaser expressly waives the right of recourse against MM Lampadari also pursuant to Article 134 of Italian Legislative Decree 206/2005 (or similar provision based on Article 3 of European Directive 1999/44/EC dated 25th May 1999).
- The obligations assumed by MM Lampadari with this Article are exhaustive and replace any warranty or liability established by law. It is thus agreed that MM Lampadari is expressly relieved of any other contractual and/or extra-contractual liability, except in cases of wilful misconduct or gross negligence by MM Lampadari, whereby originating from the Products provided and/or their resale (including, by way of mere example, compensation for direct and/or indirect damages, lost earnings, cancelled orders and penalties).
- If claims or demands by third parties are made regarding defective goods, the Purchaser who distributes the goods shall refrain – at the risk of voiding the warranty – from making any allowance, admission or offer of any nature whatsoever.

7. Self-protection

- If MM Lampadari has reason to fear that the Purchaser cannot or does not wish to pay for the goods by the date agreed, MM Lampadari may: i) suspend the delivery of goods; ii) subject the delivery of the goods to the full payment of that due or to payment terms and means different to those indicated in the Offer of Sale; iii) subject the delivery of the goods to suitable payment guarantees being made.
- In the case of missed or late payments, including those relative to other supplies, MM Lampadari may unilaterally amend the payment terms and means, including those relating to other supplies, and/or suspend the execution of such until payment has been received and/or suitable payment guarantees have been made.

8. No waiver

- Any tolerance by the fulfilling Party of conduct of the other Party regarding the obligations set out under this Contract shall not be deemed as a waiver of the fulfilling Party's rights, even if such conduct is reiterated or continued.

9. Force Majeure

- In the event of an unforeseeable event beyond the control of the Parties and which renders the execution of an individual Contract of Sale impossible (such as, by way of mere example, earthquake or other major natural disaster, epidemic, health emergency, strike, war – declared or otherwise, a revolt or revolution, boycott, embargo or any event that might even be attributable to other MM Lampadari suppliers), the Parties may suspend such execution. 2. Each party shall, in any case, promptly notify the other of any situation of force majeure which may arise and shall take every measure to limit its effect, to the extent within its power.

10. Applicable Law

- This Contract of Sale is governed by the United Nations Convention on Contracts for the International Sale of Goods (CISG; the Vienna Convention, 1980) and, for matters not covered therein, by Italian law.
- Any reference to commercial terms is understood as a reference to the Incoterms of the International Chamber of Commerce, in the text in effect on the date that this Contract is signed.

11. Jurisdiction

- Any dispute that may arise from the validity, interpretation or execution of this Contract shall be dealt with under Italian law and jurisdiction, with the Judge in the location where MM Lampadari is based having exclusive ruling powers.

12. Final Provisions

- This Contract, along with any correlated documents, is drawn up in the English language. Communications between the Parties shall be in the English language. The Parties declare knowing and being familiar with the English language.
- Any amendment to these Conditions shall be made in writing.

Certifications



Prodotto conforme ai requisiti essenziali per la commercializzazione ed utilizzo nell'Unione Europea.
Product in compliance with the essential requirements for the marketing and use in the European Union.



Prodotto conforme a tutte le normative tecniche delle procedure di valutazione dell'Unione doganale eurasiatica.
Product complies with all technical regulations of the Eurasian Customs Union evaluation procedures.



Utilizzo da interno
Indoor use



Utilizzo da esterno
Outdoor use



Prodotto dimmerabile
Dimmable



Lampadina non dimmerabile
Non-Dimmable Bulb



Tensione d'uso
Voltage



Tensione d'uso
Voltage



Lampadina a LED sostituibile
Replaceable LED bulb



Non protetto contro l'ingresso di liquidi
Not protected against liquids permeation



Modulo LED integrato non sostituibile
Integrated non-replaceable LED module



Modulo LED integrato sostituibile
Integrated replaceable LED module



Da installare con foro per incasso
Recessed installation



Prodotto orientabile
Swiveling Product



Peso netto
Net weight



Peso lordo
Gross weight

Type	Lampadine led / Led bulbs	Watt
E14		10W
E27		20W
G9		5W
Gx53		8W
GU 10		15W



Lampadina dimmerabile. La compatibilità con i sistemi di dimmerazione è indicata nelle specifiche di ogni prodotto
Dimmable bulb. Compatibility with dimming systems is indicated in the specs of each product.



Lampadina non dimmerabile - Not Dimmable

VISUAL DIRECTION AND STYLING

GIORGIO BISCARO
M.M. LAMPADARI

**STUDIO PRODUCTION,
SET DESIGN & STYLING**

M.M. LAMPADARI
LAURA POZZI

PHOTOGRAPHY

ASOLANAGROUP
ANTONIO CAMPANELLA
ALESSANDRO DI BON
FEDERICO MARIN
STUDIO ROCCI

COLOUR CALIBRATION

GM STUDIO1

THANKS TO

AGAPE
ARLEX ITALIA
CERAMICHE MILESI
COLLEZIONI
DOIMO CUCINE
F.LLI CALEGARO
HAFROGEROMIN
IL CESELLO
JESSE
KASTHALL
KREOO
LEMA
LITTLE OWL
MADE A MANO
MARAZZI GROUP
MATTEO PALA
MATTEO ZORZENONI
MAURO BOLOGNESI
MINIFORMS
MOLTENI & C
MOROSO
OFFICINA N°3
SCAPIN
SCULPTURE JEUX
SONIA PEDRAZZINI
RONCATO VALIGERIA
RUBINETTERIA GIULINI
WOOBAG
WOODMOON

Tutti i prodotti MM Lampadari S.r.l. sono conformi alle direttive Europee in vigore. Ogni articolo prodotto presentato nel catalogo é realizzato e decorato artigianalmente, pertanto lievi differenze nelle dimensioni, nel colore o nei dettagli costituiranno il carattere di unicità proprio della lavorazione manuale.

All MM Lampadari S.r.l. Products comply with the European directives in force. Each product presented in the catalogue is produced and decorated by hand; therefore, slight colour, size or detail differences will make the unique character in the handwork.

MM Lampadari S.r.l. si riserva il diritto di intervenire in qualunque momento e senza preavviso per apportare le modifiche che ritenesse più opportune per migliorare il prodotto o in risposta a qualsiasi esigenza di carattere normativo costruttivo o commerciale.

MM Lampadari S.r.l. reserves its right to intervene in every moment and without forewarning in order to make the modifications more suitable to improve the product or reply to each legal, manufacturing or commercial requirement.



© M.M. LAMPADARI. È vietata la riproduzione anche parziale di questo catalogo

© M.M. LAMPADARI. It is forbidden to reproduce any part of this catalogue



mmlampadari