

A

C

Q

NEWS 2024

U

E

R





PAOLO CASTELLI

E

LL

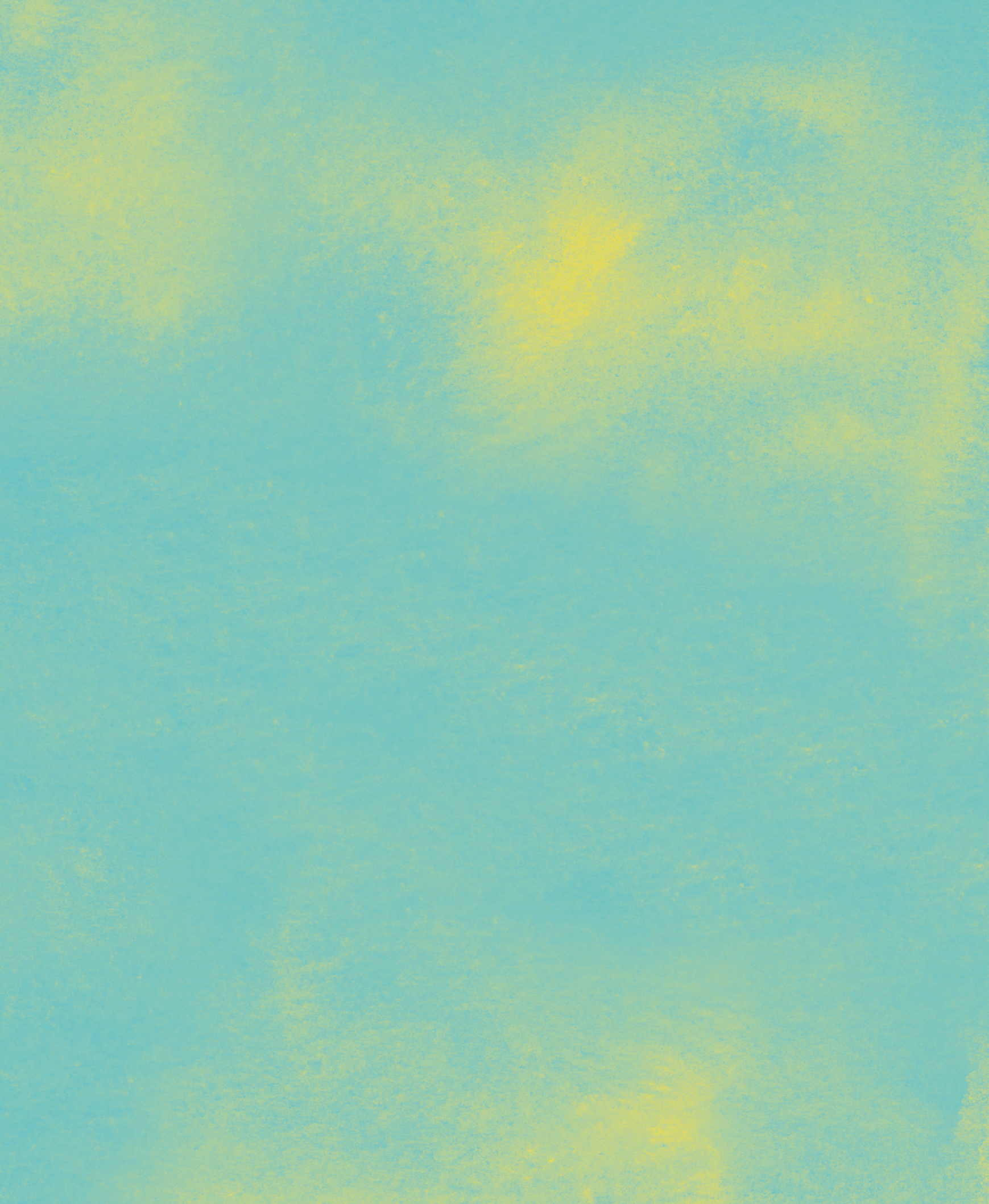
O



PAOLO CASTELLI

IT Paolo Castelli S.p.A. è azienda italiana leader nel settore del design e del global contracting a livello nazionale e internazionale. Nata da un'intuizione di Paolo Castelli, l'azienda ha saputo coniugare tradizione e innovazione dando vita a collezioni indoor e outdoor "total look" sempre attuali in grado di raccontare la contemporaneità, anticipando le tendenze e rispondendo alle esigenze del mercato. Paolo Castelli S.p.A è in grado di soddisfare le esigenze dei progettisti e le richieste del cliente finale offrendo soluzioni custom made sviluppate intorno ai concetti di eccellenza e alta qualità: una visione dinamica che ha condotto l'azienda italiana a diventare il partner ideale per ambiziosi progetti contract in tutto il mondo.

EN Paolo Castelli S.p.A is a leading Italian company in the design and global contracting sector at a national and international level. Born from an intuition of Paolo Castelli, the company has been able to combine tradition and innovation by creating ever-present "total look" indoor and outdoor collections able to describe the contemporaneity, anticipating trends and responding to market requests. Paolo Castelli S.p.A is able to satisfy the needs of designers and the wishes of the end customer by offering custom made solutions developed around the concepts of excellence and high quality: a dynamic vision that has led the Italian company to become the ideal partner for ambitious projects contract all over the world.

ACQUERELLO

Fenpei Modular Sofa, Coffee Tables ^{P.10}, Labilis Mega Ring Suspension Lamp ^{P.16}, Giano Chair ^{P.20},
Dione Dark Table, Coffee Tables ^{P.22}, Illusio Suspension Lamp, Wall Lamp ^{P.24}, Elegance Soft Sofa ^{P.28},
Crudelia Armchair ^{P.30}, Nucleo Table, Lounge Tables, Console ^{P.34}, Gong Decorative Object ^{P.42},
Fenpei Modular Outdoor Sofa ^{P.48}, U Outdoor Chair ^{P.52}, Kenya Table, Coffee Tables, Console ^{P.54},
Haibu Suspension Lamp ^{P.60}



*"A photograph to me is always a reminder of how the person was on a certain day in that certain light fixed.
When i look at a watercolour that same person, it seems to me alive, more open that a photograph."*
Francesco Clemente

IT Una sinfonia di delicati equilibri tra proporzioni, fantasia e ricerca. Un'armonia di materiali, finiture e pregiate essenze che trova spontaneamente collocazione in spazi pervasi da un intimismo naturalistico, in atmosfere sospese tra realtà e sogno. Acquerello è la nuova collezione 2024 di Paolo Castelli, un'ode al sussurrato dialogo tra forma e colore e alla pura libertà espressiva. Arredi indoor, outdoor e sistemi d'illuminazione disegnati e concepiti per tracciare un'idea di bellezza, in un racconto fatto di segni e oggetti, simboli e rituali semplici. Originale e raffinata, l'anima artigianale degli arredi scalza un linguaggio modernista teso quasi esclusivamente alla funzionalità in virtù di un'estetica emozionale e decorativa che invita la mente a viaggiare, libera di intuire un altrove.

"L'acquerello rappresenta per me "freschezza". Penso alla sua leggerezza e alla presenza imprescindibile dell'elemento naturale, con il loro potenziale estetico e cromatico. Nasce da questi presupposti la collezione Acquerello, dove ogni arredo dipinge un ritratto sospeso tra eleganza eterea e una profonda connessione con la natura, plasmando uno spazio che supera il concetto di mero rifugio domestico, trasformandosi in una serie di paesaggi pronti per essere vissuti e scoperti." Paolo Castelli

EN A symphony of delicate balances between proportions, imagination, and research. A harmony of materials, finishes, and precious essences that spontaneously finds its place in spaces pervaded by naturalistic intimism, in settings suspended between dream and reality. Acquerello is the newest 2024 collection by Paolo Castelli – a true ode to the whispered dialogue between form and colour and to the pure freedom of expression. Indoor and outdoor furniture as well as lighting systems designed and conceived to trace an idea of beauty in a tale made of signs and objects, symbols, and simple rituals. Original and refined, the handcrafted soul of the furnishings undermines the modernist language – aimed almost exclusively at functionality – by virtue of an emotional and decorative aesthetic, thus inviting our mind to travel and to freely imagine an elsewhere place.

"Watercolors represent 'freshness' to me. I think of their lightness and the essential presence of natural elements, with their aesthetic and chromatic potential. It is from these premises that the Acquerello collection was born, where each piece of furniture paints a picture suspended between ethereal elegance and a deep connection with nature. It shapes a space that goes beyond the concept of mere domestic refuge, transforming itself into a series of settings ready to be experienced and discovered." Paolo Castelli



INDOOR

Fenpei Modular Sofa, Coffee Tables ^{P.10}, Labilis Mega Ring Suspension Lamp ^{P.16}, Giano Chair ^{P.20},
Dione Dark Table, Coffee Tables ^{P.22}, Illusio Suspension Lamp, Wall Lamp ^{P.24}, Elegance Soft Sofa ^{P.28},
Crudelia Armchair ^{P.30}, Nucleo Table, Lounge Tables, Console ^{P.34}, Gong Decorative Object ^{P.42}

IT Fenpei arreda gli ambienti con lavorazioni pregiate e l'audacia di un sistema flessibile composto da moduli che si trasformano in soffici ed accoglienti isole di lusso. Ogni modulo è definito da una cucitura decentrata che determina la scissione della seduta e degli schienali in due sezioni con colori a contrasto. Fenpei è composto da morbidi elementi, imbottiti in poliuretano a densità differenziata avvolti da una plumette in fiocco di microfibra, che alternano le quattro varianti di seduta e i due schienali disponibili. Gli schienali, zavorrati, possono essere posizionati liberamente, o essere ancorati alle sedute grazie ad un funzionale e raffinato alamaro in bamboo che, agganciandosi ad un laccio in cuoio posto sulla seduta, regola le quattro posizioni dello schienale. Il basamento in metallo, finitura epossidica Bronze Shadow opaco, sostiene il volume confermando l'incredibile sensazione di leggerezza. Un equilibrio che assicura massimo comfort adattandosi a ogni ambiente, sia classico che contemporaneo.

EN Fenpei furnishes rooms with fine workmanship and the boldness of a flexible system composed of modules that transform into soft and welcoming islands of luxury. Each module is defined by an off-center seam that results in the splitting of the seat and seatback into two sections with contrasting colours, thus creating a colour play having strong graphic impact. Fenpei is composed by padded elements made of differentiated-density polyurethane wrapped in a microfiber staple plumette that alternate between the four available seat and two seatback variations. The counterweighted backseats can be positioned freely or anchored to the seats thanks to a functional and refined bamboo frog that sets the four seatbacks by hooking onto a leather lace placed on the seat. The metal base, featuring matt Bronze Shadow epoxy finish, supports the overall volume, thus highlighting once again the incredible feeling of lightness. A balance that ensures maximum comfort and adapts to any environment – be it classic or contemporary.

FENPEI MODULAR SOFA, COFFEE TABLES







IT Tavolini rettangolari in due misure, oggetti multifunzionali che propongono un'alternanza asimmetrica di forme essenziali. Volumi pieni e vuoti sostenuti dal medesimo basamento del divano, in metallo finitura Bronze Shadow opaco. Realizzati in legni multistrato di frassino brunito Olivato Chiaro e Olivato Scuro, sono progettati per sottolineare un'armonia geometrica di contrasti perfettamente equilibrati.

EN Rectangular coffee tables offered in two sizes, decorative and multifunctional objects that offer an asymmetrical alternation of essential forms. Full and empty volumes supported by the same metal base as the sofa featuring a matt Bronze Shadow finish. Made of Dark Olive or Light Olive hand-brushed ash plywood, these tables are designed to emphasize a geometric harmony of perfectly balanced contrasts.

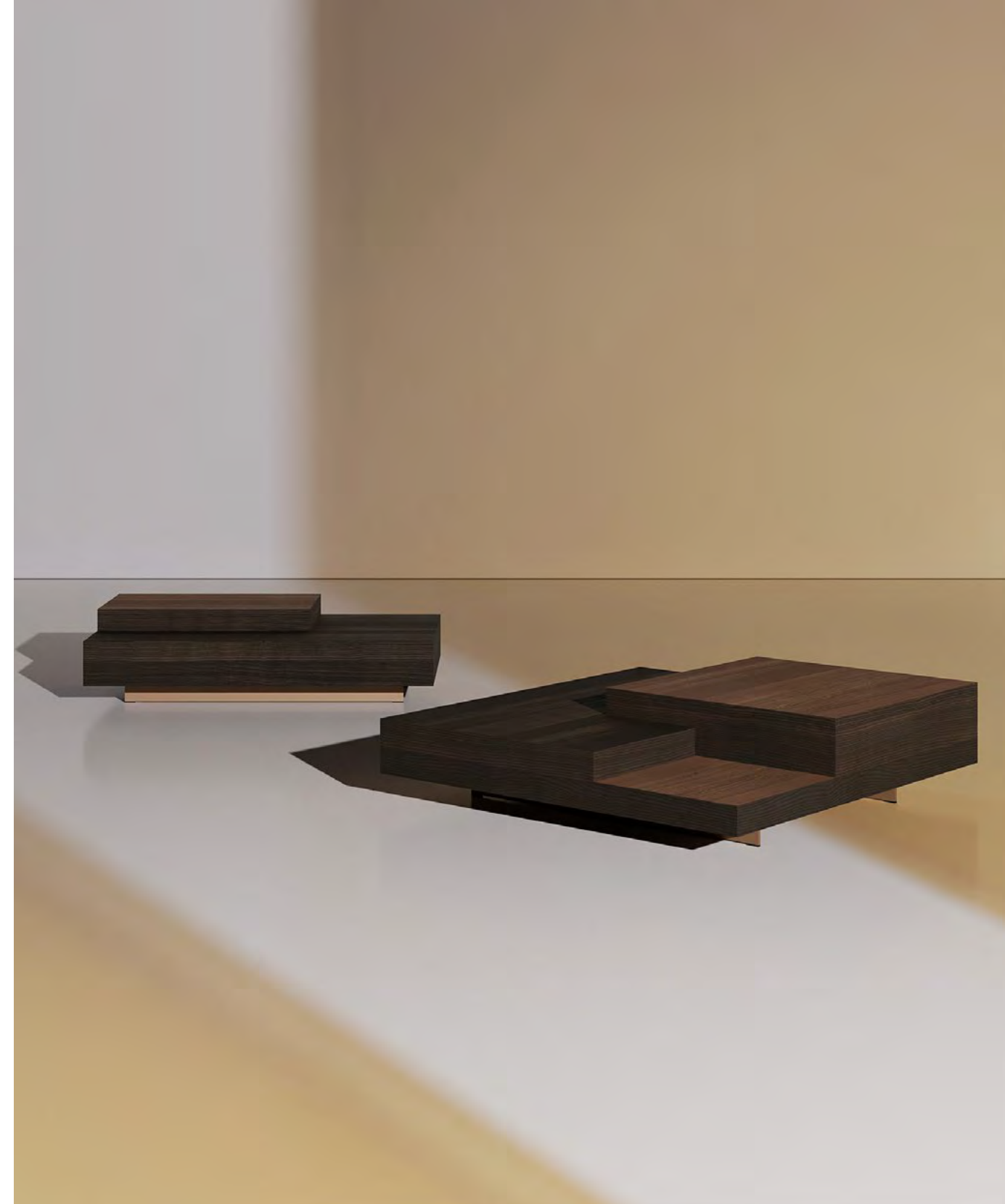



LABILIS MEGA RING SUSPENSION LAMP

IT Un nuovo alfabeto grafico fatto di essenziali elementi geometrici che disegnano nello spazio contemporanee forme di luce. La famiglia Labilis, accoglie Labilis Mega Ring, sistema d'illuminazione a sospensione caratterizzato da dimensioni estremamente generose, in armonioso contrasto con il suo profilo essenziale. L'anello in metallo, finitura Nero opaco con diffusore di luce LED in policarbonato opalino Bianco perimetrale, è impreziosito da quattro spot in ottone finitura Bronzo opaco.

EN A new graphic alphabet made of essential geometric elements that draw contemporary forms of light in space. The Labilis family welcomes Labilis Mega Ring, a suspension lighting system characterized by extremely generous dimensions harmoniously contrasting with its essential profile. The main metal ring, featuring matt Black finish with perimeter White opal polycarbonate LED light diffuser, is embellished with four brass spots in brass Bronze matt finish.



IT Comfort ed ergonomia si combinano in un gioco grafico di linee dinamiche. La sedia Giano interpreta con disinvoltura una classica seduta con struttura in legno, definita dall'apparente incontro delle due gambe posteriori nella sezione centrale, prolungate verso lo schienale a determinarne la perfetta scissione in due elementi gemelli. Oltre che nel distintivo disegno dello schienale, l'essenza duale di Giano si rivela nelle due versioni disponibili, con struttura in legno di frassino tinto Noce o frassino tinto Nero. Seduta e schienale sono imbottiti e rivestiti con una vasta selezione di tessuti indoor a catalogo.

EN Comfort and ergonomics combine in a graphic play of dynamic lines. The Giano chair represents a classic seat with a wooden frame defined by the apparent meeting of the two back legs in the central section, which extend towards the seatback to determine its perfect split into two twin elements. In addition to the distinctive design of the seatback, Giano's dual essence is revealed in its two versions available, with Walnut or Black stained ash wood frame. Both seat and backrest are upholstered and covered with a wide selection of indoor fabrics present in our catalogue.

GIANO CHAIR



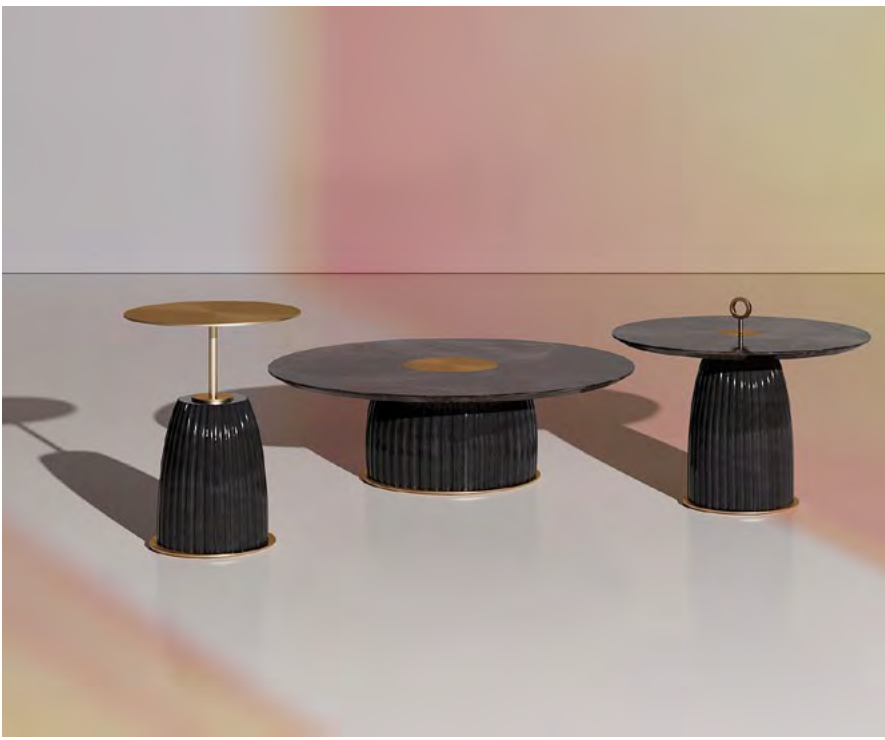

DIONE DARK TABLE, COFFEE TABLES

IT Dione Dark è un'inedita proposta formata da tavolo e tavolini composti da una base a forma di campana, realizzata in ceramica da maestri artigiani con una lavorazione a coste smaltata Grigio Antracite, in contrasto con il piano circolare, realizzato in marmo Sahara Brown lucido e impreziosito da un intarsio centrale in ottone.

EN Dione Dark is an unprecedented proposal consisting of a main table and small tables composed of a handcrafted, ceramic, bell-shaped base featuring a glossy Charcoal Grey glazed ribbed finish, an effect contrasting with its circular top made of polished Sahara Brown marble and embellished with a central brass inlay work.



IT Illusio evoca mistero e magia trasformando completamente la percezione dello spazio.
Un sistema d'illuminazione componibile, a sospensione e a parete, formato da sette rami in ottone di cui cinque accolgono la fonte luminosa LED, formando un rassicurante nido di luce in grado di illuminare gli interni con fasci di luce ritmati. Una famiglia di elementi dal carattere deciso, capaci di delineare paesaggi di luce dinamici, animati da giochi di luce inaspettati e suggestivi.

EN Illusio evokes mystery and magic by completely transforming the perception of space. A modular lighting system, either hanging or wall lamp, formed by seven brass branches, five of which accommodate the LED light source, thus creating a reassuring nest of light capable of illuminating interiors with rhythmic beams of light. A family of elements with a strong character, capable of outlining dynamic light landscapes, animated by unexpected and suggestive shadow plays.

ILLUSIO SUSPENSION LAMP, WALL LAMP

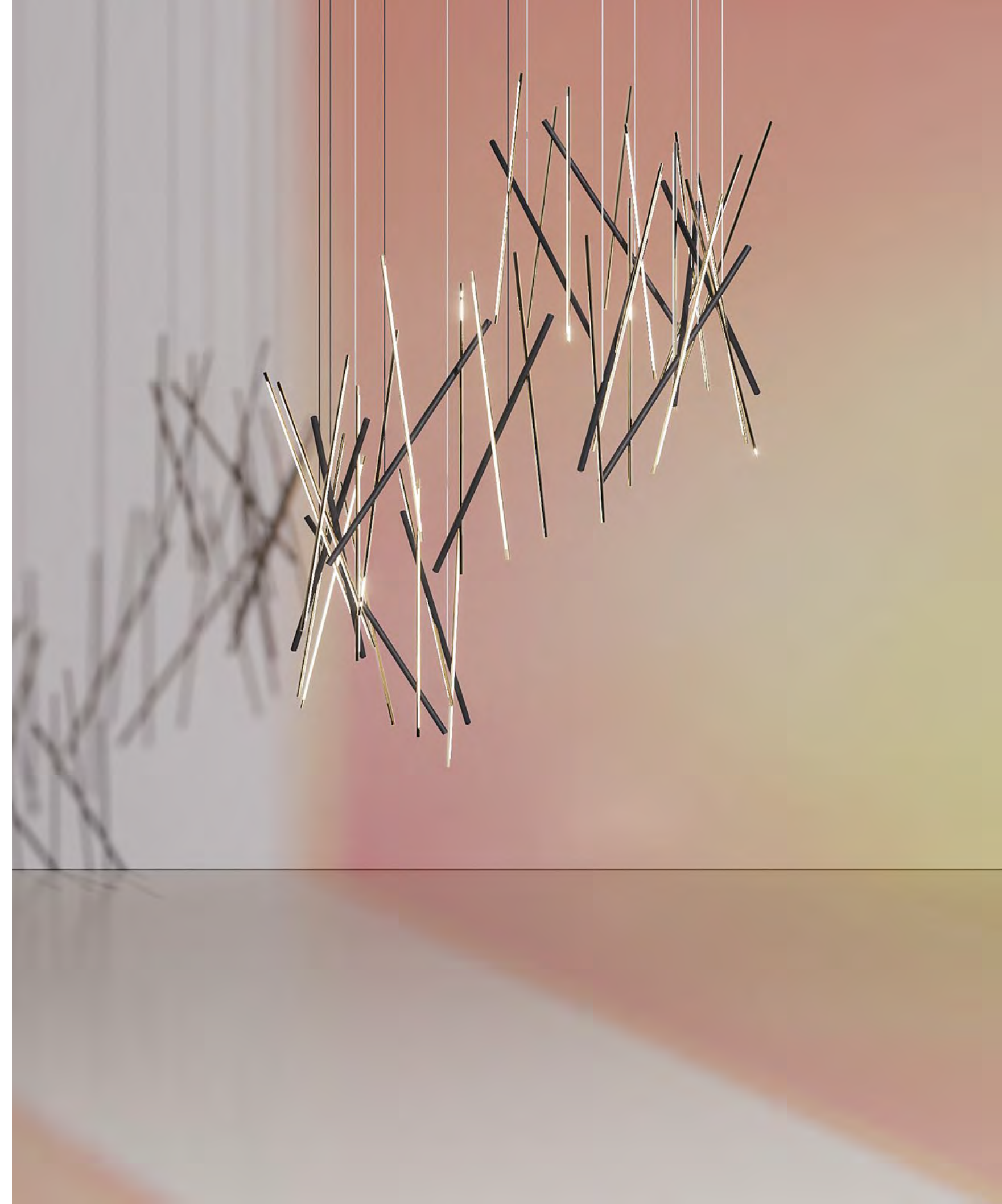
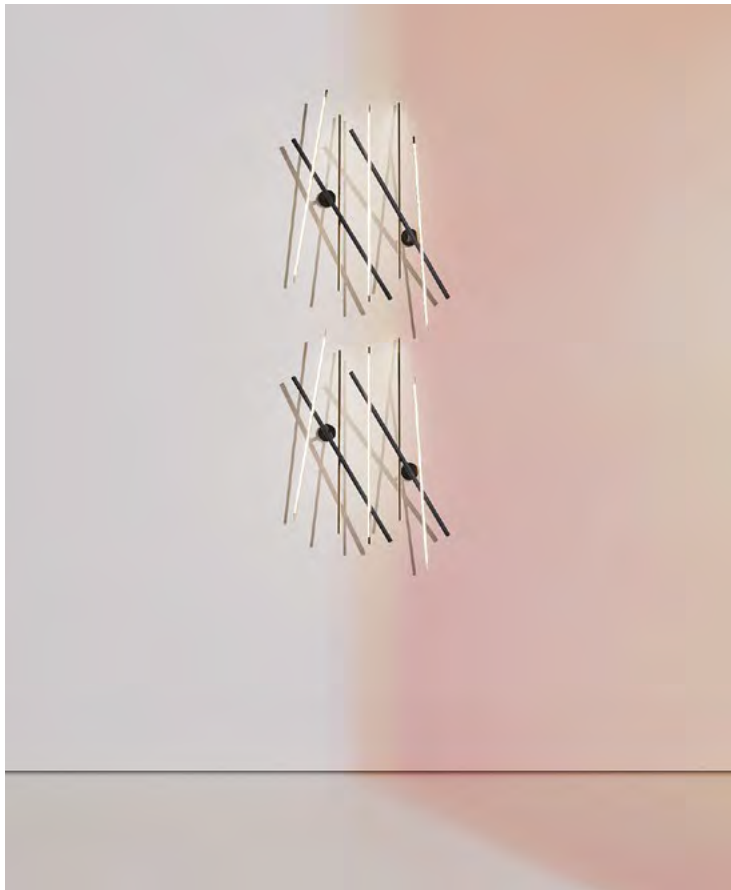





ELEGANCE SOFT SOFA

IT Elegance Soft è un divano con base a terra dalle forme scolpite, accogliente e soffice, definito da uno stile lineare e rilassato. Le proporzioni equilibrate e la rigorosa geometria della struttura imbottita accolgono generosi cuscini di seduta, schienali bassi e braccioli a tutta lunghezza, in poliuretano a densità differenziata avvolti da una plumette in fiocco di microfibra, offrendo il comfort di un sistema di sedute dalle forme soffici, semplici ed estremamente accoglienti. Il Basamento è in legno rivestito in pelle laminata Bronzo e piedi in faggio tinto Nero opaco. Attualizzato nelle dimensioni, nelle proporzioni e nella profondità di seduta al fine di ottenere un risultato classico, ma al tempo stesso capace di offrire una versatilità al passo con le mutevoli esigenze del mondo dell'abitare.

EN Elegance Soft sofa is a floor-standing, cozy and soft sofa featuring sculpted forms, defined by a linear and relaxed style. The balanced proportions and rigorous geometry of the upholstered structure greet generous seat cushions, low backseats and full-length armrests, upholstered in differentiated density polyurethane wrapped in a microfiber staple plumette, which offers the comfort of a seating system with soft, simple, and extremely welcoming shapes. Its base is made of wood covered in Bronze laminated leather as opposed to its feet made of matt Black stained beech. Featuring new size, proportions, and depth of seating to achieve a more classic result, this sofa is at the same time capable of offering versatile furniture solutions keeping up with the changing needs of the world of living.



IT Crudelia si impone nel panorama domestico con l'audacia delle sue forme e l'ironia che manifesta nella sua essenza. Un contemporaneo seggio per chi desidera vigilare da una posizione privilegiata il sacro santuario della propria casa, un trono che si compone di pochi e semplici elementi. Un cono ascendente si sviluppa dal basso, incorporando il morbido cuscino di seduta e lo schienale. Le due gambe anteriori, di forma cilindrica, sono realizzate in legno di frassino massello poro aperto tinto Nero e rifinite agli apici con l'inclusione di preziosi emisferi di ottone incisi a laser. Seduta e schienale sono rivestiti con tessuti indoor. Anticonformista e liberatoria, Crudelia è una seduta contemporanea che diffonde energia in qualsiasi ambiente venga collocata.

EN Crudelia imposes itself on the domestic scene with the boldness of its forms and the irony it manifests in its essence. A contemporary seat for those who wish to watch over the sacred sanctuary of their home from a privileged position. A throne that is composed of a few simple elements. An ascending cone develops from below, incorporating the soft seat cushion and backrest. The two cylindrical-shaped front legs are made of solid, black-stained, open-pored ash wood, while its apexes feature a finish including precious laser-etched brass hemispheres. Both seat and backrest are upholstered with indoor fabrics. Nonconformist and liberating, Cruella is a contemporary seat that spreads energy in any setting it is placed.

CRUDELIA ARMCHAIR





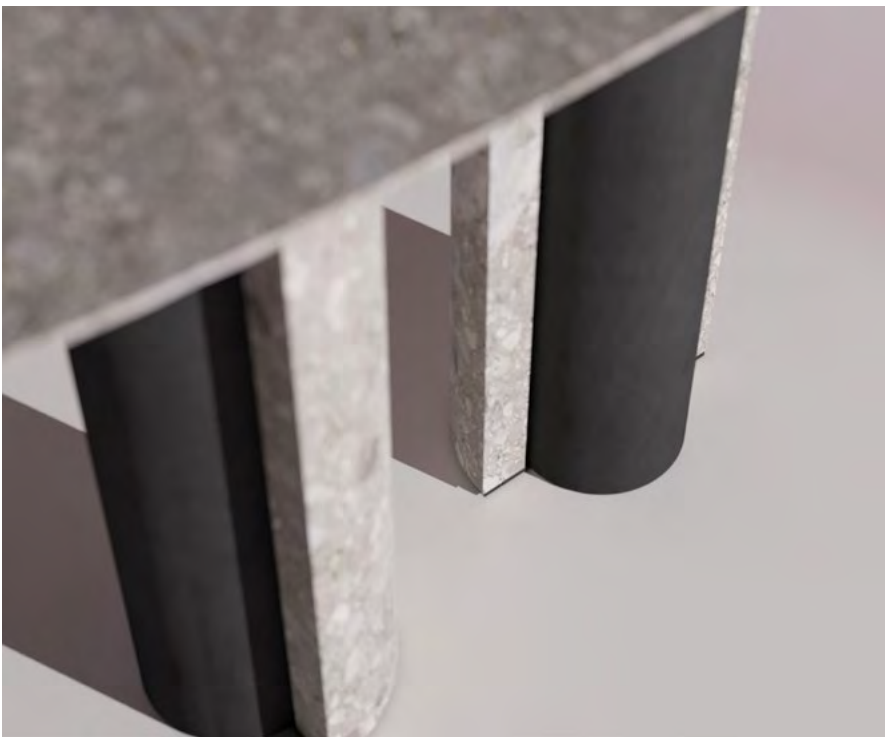

NUCLEO TABLE, LOUNGE TABLES, CONSOLE

IT Nucleo celebra la pura naturalezza delle forme e dei materiali, proponendo soluzioni che prediligono fogge biomorfe, perfette nella loro imperfezione. Tavolo, tavolo lounge e console abilmente lavorati da esperte mani artigiane in un equilibrio estetico di volumi equilibrati, esaltati da forme dinamiche e materiali dal carattere deciso. Il tavolo e la console sono definiti da una silhouette scultorea realizzata attraverso l'impiego decorativo e strutturale della pietra Dolomia. Alla brillantezza calcarea del minerale si integra la struttura portante in metallo finitura Calamina o Bronze Shadow opaco, visibile attraverso le sezioni che caratterizzano la ricerca estetica delle gambe, a sostegno del top attraverso un ritmo asimmetrico ed inaspettato.

Nel tavolo lounge, legno, pietra e metallo si completano a vicenda, creando un insieme armonico dalla forte identità. Il risultato è un richiamo alla complessa semplicità che accompagna armonicamente la convivialità, le azioni e le relazioni disegnate intorno alla tavola.

EN Nucleo celebrates the pure naturalness of forms and materials, thus offering solutions that favour biomorphic fashions, perfect in their imperfection. Table, lounge table, and console, skilfully crafted by expert artisan hands in an aesthetic balance of balanced volumes, are enhanced by dynamic shapes and materials featuring strong character. The table and the console are defined by a sculptural silhouette created through the decorative and structural use of Dolomia. The limestone brilliance of the mineral is complemented by the supporting structure in Calamine or Bronze Shadow matt metal finish, visible through the sections that characterize the aesthetic research of its legs, supporting the top through an asymmetric and unexpected rhythm. In the lounge table, wood, stone, and metal complement each other, thus creating a harmonious whole owning a strong identity. The result is a reminder of the complex simplicity that harmoniously accompanies conviviality, actions, and relationships designed around the table.







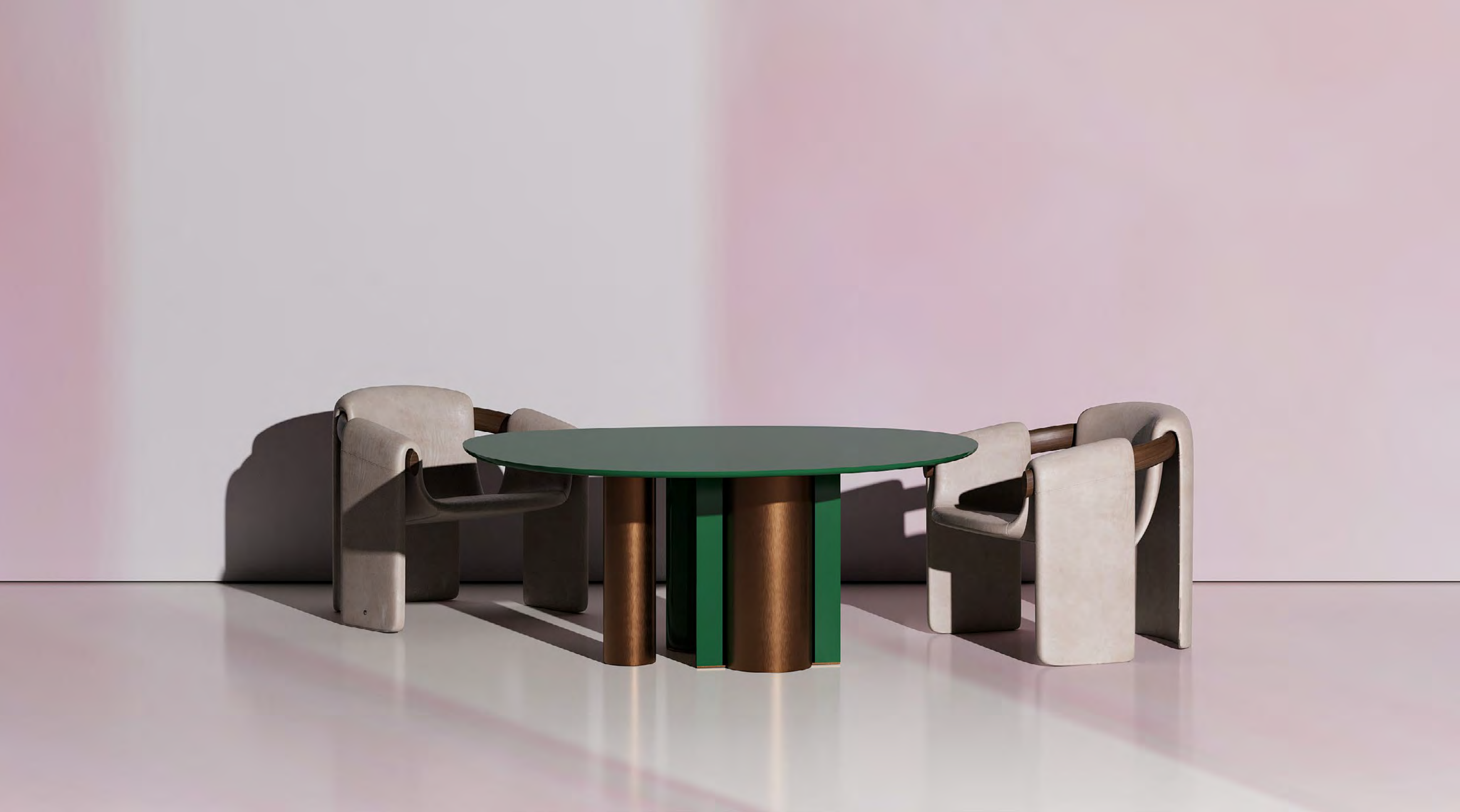

IT Un maestoso oggetto decorativo da parete del diametro di 2 metri. Con Gong l'impatto visivo della materia cristallina e il rigore formale si uniscono in un oggetto dal fascino magnetico. Una parabola di vetro argentato in fusione con effetto martellato che celebra la fluidità e il rapporto tra luce e materia attraverso le ondulazioni impresse nella superficie. Oggetto fluido dall'anima enigmatica, forgiato dal fuoco, è disponibile nelle varianti cromatiche Bronzo e Argento.

EN A majestic decorative wall object featuring a diameter of 2 meters. With Gong, the visual impact of crystalline material and formal rigor come together in an object magnetically appealing. A parabola of cast silvered glass featuring a hammered effect that celebrates fluidity and the relationship between light and matter through the undulations impressed in the surface. A fluid object with an enigmatic soul forged by fire, it is available in two variants, Bronze and Silver.

GONG DECORATIVE OBJECT

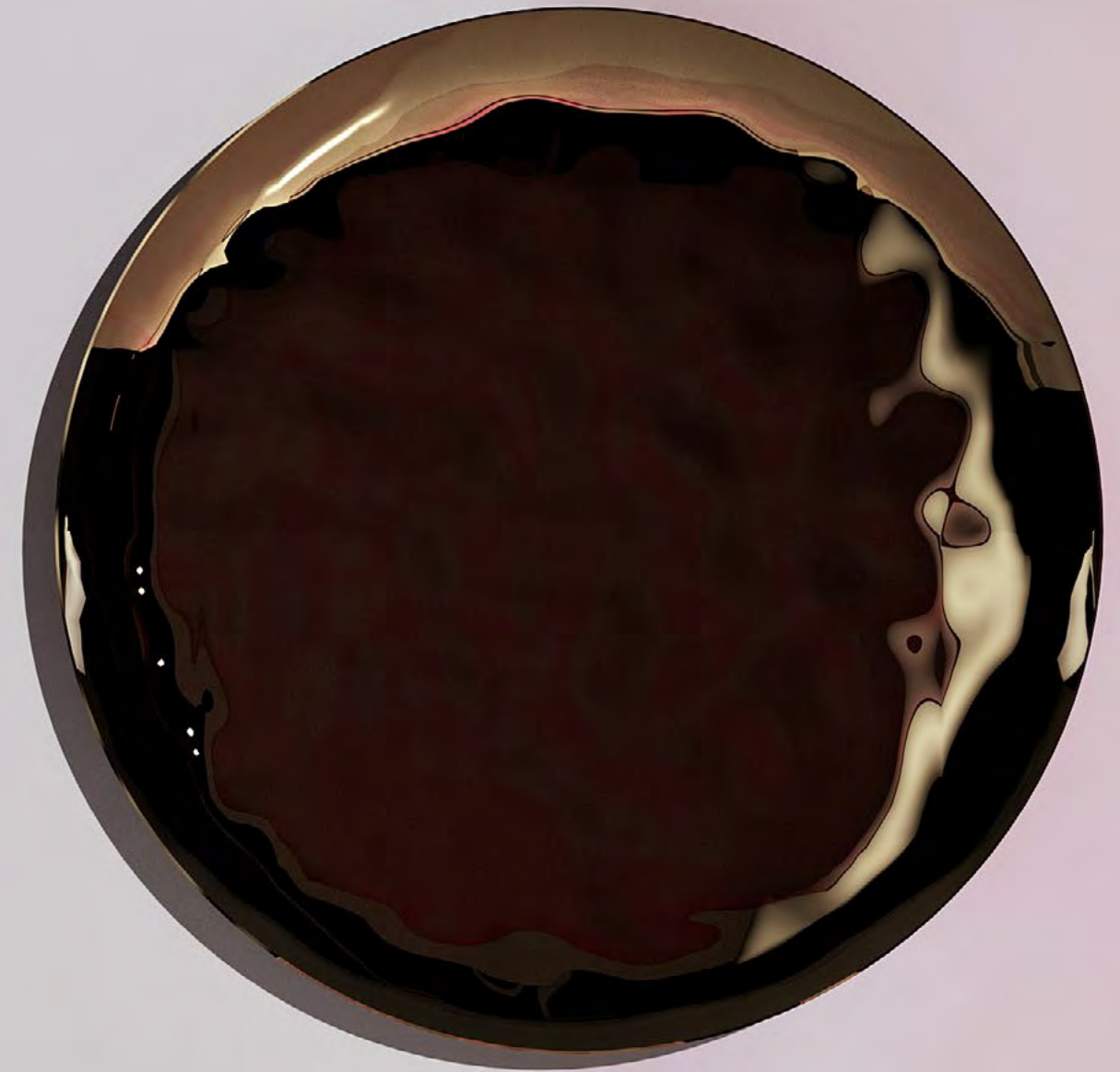





OUTDOOR

Fenpei Modular Outdoor Sofa ^{P.48}, U Outdoor Chair ^{P.52},
Kenya Table, Coffee Tables, Console ^{P.54}, Haibu Suspension Lamp ^{P.60}



FENPEI MODULAR OUTDOOR SOFA

IT Fenpei Outdoor arreda anche gli ambienti esterni con lavorazioni pregiate e l'audacia di un sistema flessibile composto da moduli che si trasformano in soffici ed accoglienti isole di lusso. Ogni modulo è definito da una cucitura decentrata che determina la scissione della seduta e degli schienali in due sezioni con colori a contrasto. Il sistema è composto da quattro elementi di seduta e due varianti di schienale, imbottiti in poliuretano a densità differenziata, avvolti da una plumette in fiocco di microfibra e rivestiti in tela idrorepellente. Gli schienali, zavorrati, possono essere posizionati liberamente, o essere ancorati alle sedute grazie ad un funzionale e raffinato alamaro in bambo che, agganciandosi ad un laccio in cuoio posto sulla seduta, regola le quattro posizioni dello schienale. Il basamento in acciaio, finitura Bronze Shadow opaco, sostiene il volume confermando l'incredibile sensazione di leggerezza.

EN Fenpei Outdoor also furnishes outdoor spaces with fine workmanship and the boldness of a flexible system composed of modules that transform into soft, cozy islands of luxury. Each module is defined by an off-center seam that results in the splitting of the seat and backseats into two sections featuring contrasting colours, thus creating a colour play with a strong graphic impact. The system consists of four seating elements and 2 backrest options, upholstered in differentiated-density polyurethane wrapped in a microfiber staple plumette and covered in water-repellent canvas. The counterweighted backseats can be positioned freely or anchored to the seats thanks to a functional and refined bamboo frog that sets the four backseats by hooking onto a leather lace placed on the seat. The steel base, featuring matt Bronze Shadow epoxy finish, supports the overall volume, thus highlighting once again the incredible feeling of lightness.





IT La sedia U conquista nuovi palcoscenici presentandosi come supporto ideale per un relax composto anche all'aperto. Il suo comfort è definito da una seduta dalla profondità accentuata e leggermente inclinata, in virtù di un linguaggio semplice ma sofisticato. La struttura, leggera alla vista ma solida nella funzione, in acciaio verniciato con finiture outdoor, sostiene sedile e schienale in simil cuoio EVA, nelle varianti Mattone e Crema, semplicemente calzato attraverso lo schienale e i braccioli. La perfetta sintesi compositiva di U Outdoor propone ampia versatilità nell'utilizzo, permettendo di rivisitare in chiave contemporanea qualunque tipologia di spazio.

EN The U chair conquers new stages by presenting itself as an ideal support for compound relaxation even outdoors. Its comfort is defined by a seat with accentuated depth and a slight slope, by virtue of a simple yet sophisticated language. Its structure, light to the eye yet solid in function in painted steel with outdoor finishes, supports seat and backseat in EVA leatherette available in two colours, Brick and Cream. The perfect compositional synthesis of U Outdoor offers wide versatility in use, allowing any type of space to be revisited in a contemporary way.

U OUTDOOR CHAIR





KENYA TABLE, COFFEE TABLES, CONSOLE

IT La familia Kenya offre un nuovo palcoscenico di condivisione all'aria aperta. Una proposta composta da tavolo, tavolini e console, dal forte carattere architettonico, una soluzione completa e versatile che arreda con carattere spazi living e dining anche in esterni. I volumi sottratti che caratterizzano la base di ciascun elemento si uniscono al piano d'appoggio rettangolare, conferendo alla collezione un aspetto inusuale che rende omaggio all'asimmetria. L'incontro materico tra le gambe, in poliuretano alta densità intelaiate in acciaio inox verniciato epossidico, e rivestite con un impasto di travertino, e il top, in travertino Bianco o Rosso, caratterizzano ogni elemento grazie alla bellezza imperfetta della pietra naturale. Superfici dalla trama irregolare definiscono questa dinamica soluzione evocando con immediatezza paesaggi naturali incontaminati.

EN The Kenya family introduces a new stage for outdoor sharing. A proposal composed of main table, side tables, and console featuring a strong architectural character, it represents a complete and versatile solution that furnishes with character living and dining spaces en plein air. The subtracted volumes defining the structure of each element combine with the rectangular table top, thus giving the collection an unusual appearance that pays homage to asymmetry. The textural encounter between its high-density polyurethane legs framed in epoxy-painted stainless steel and covered with a mixture of travertine, and its top made in White or Red travertine, characterize each element through the imperfect beauty of natural stone. Irregularly textured surfaces define this dynamic solution, thus evoking natural and pristine landscapes with immediacy.







IT Una tecnologia d'avanguardia e materiali dal sapore naturale sono gli elementi chiave che definiscono Haibu. Un progetto innovativo che ha come protagonisti luce, stampa 3D e la funzionale versatilità del gres. Per la prima volta utilizzato nel settore dell'arredo di lusso in questa veste, il gres viene plasmato da un innovativo processo di stampa 3D dando vita a delle lanterne outdoor che accolgono nella loro calda e rassicurante luce. Il materiale, in fase di stampa e asciugatura, ricade spontaneamente su sé stesso creando un pattern di fessure che lasciano fuoriuscire dolci fasci di luce. Il design ricercato si fonde quindi con le proprietà intrinseche della materia in un sistema di illuminazione durevole che invita a sperimentare momenti di relax all'aria aperta. Disponibile in due versioni.

EN Cutting-edge technology and natural-flavoured materials are the key elements that define Haibu, an innovative project featuring light, 3D printing, and the functional versatility of stoneware. For the first time used in the luxury furniture sector in this capacity, stoneware is shaped by an innovative 3D printing process, giving rise to outdoor lanterns that welcome in their warm and reassuring light. As the material is printed and dried, it spontaneously falls back on itself, thus creating a pattern of slits that allow gentle beams of light to escape. The refined design then blends with the intrinsic properties of the material in a durable lighting system that invites to experience moments of relaxation in the open air. This suspension lamp is available in two versions.

HAIBU SUSPENSION LAMP

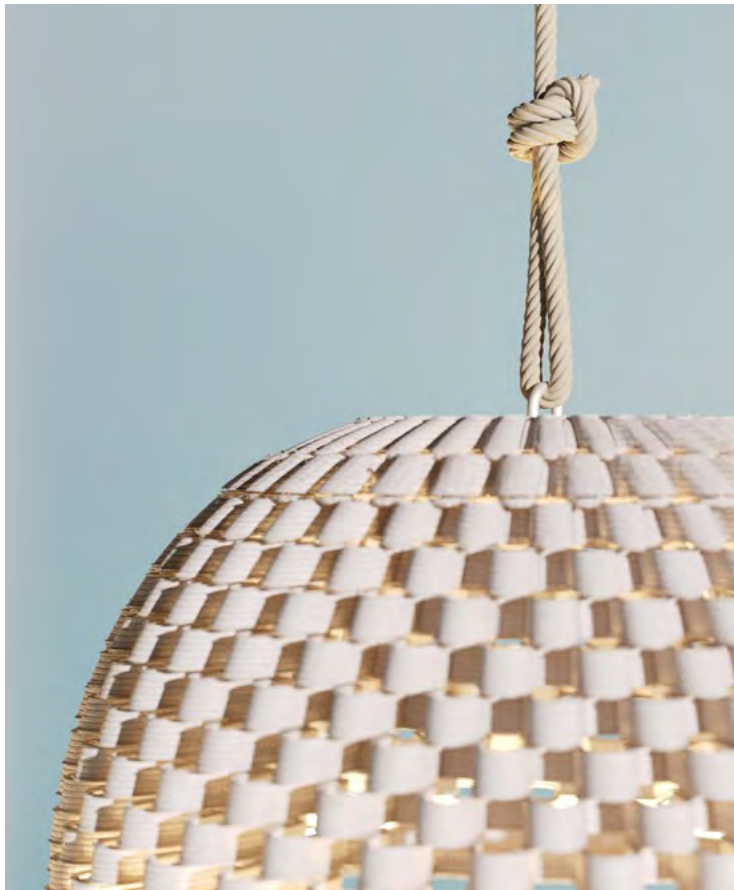





TECHNICAL DATA



FENPEI MODULAR

MATERIALS

Structure: metal, wood
Upholstery: indoor fabrics

FINISHES

Structure: bronze shadow matt finish
Upholstery: Fabrics cat. Superior, Deluxe, Leather, Nubuck

FENPEI MODULAR OUTDOOR

MATERIALS

Structure: stainless steel, wood
Upholstery: outdoor fabrics

FINISHES

Structure: bronze shadow matt finish
Upholstery: Fabrics cat. Outdoor

SINGLE COMPONENTS

main components

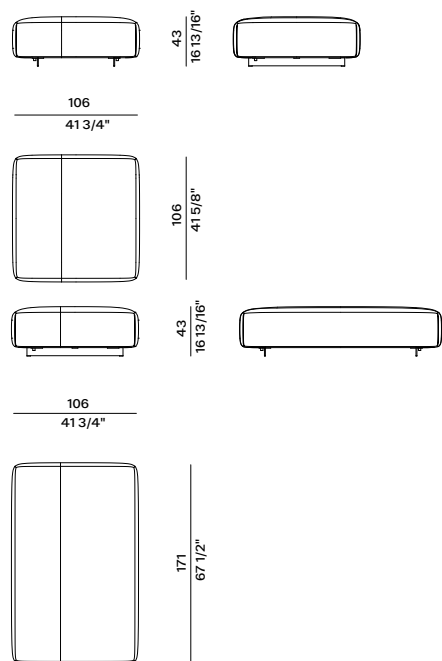

connection components

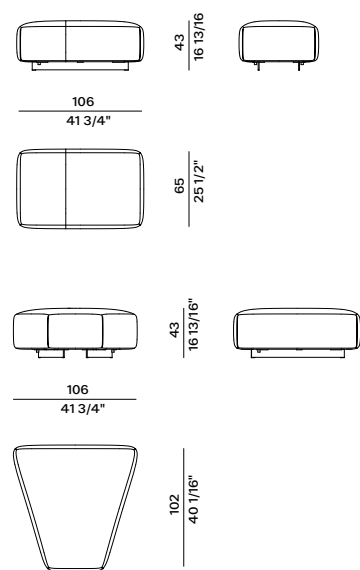

backrests

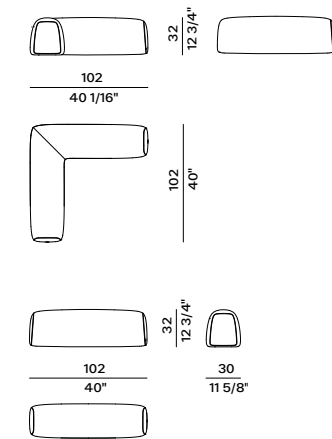

pillows

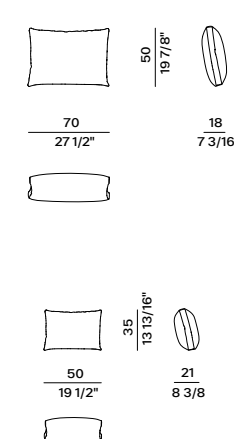

COMPOSITIONS

FP-006

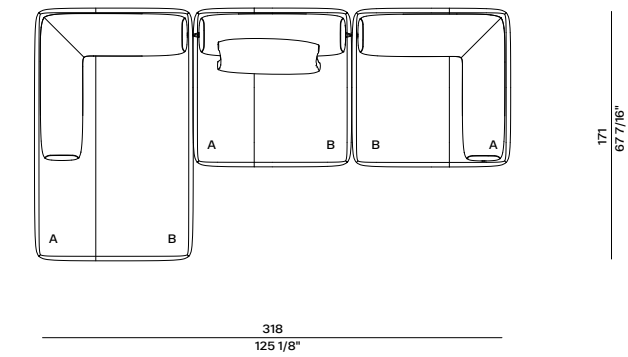

FP-008

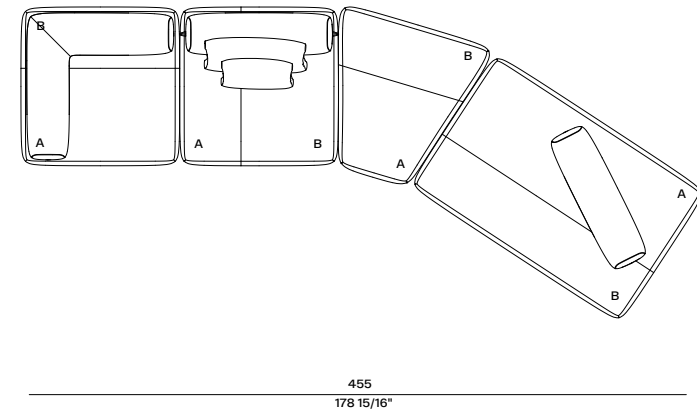

FP-009

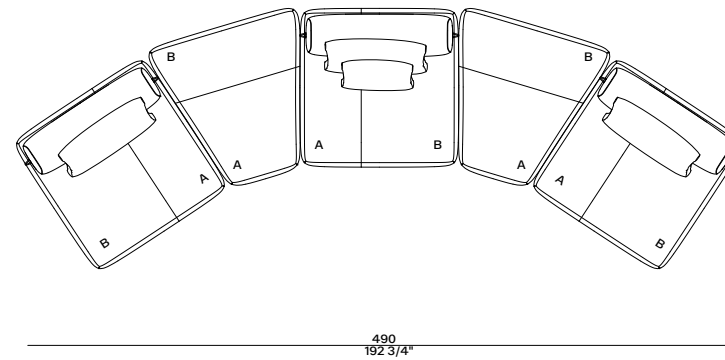

FP-010

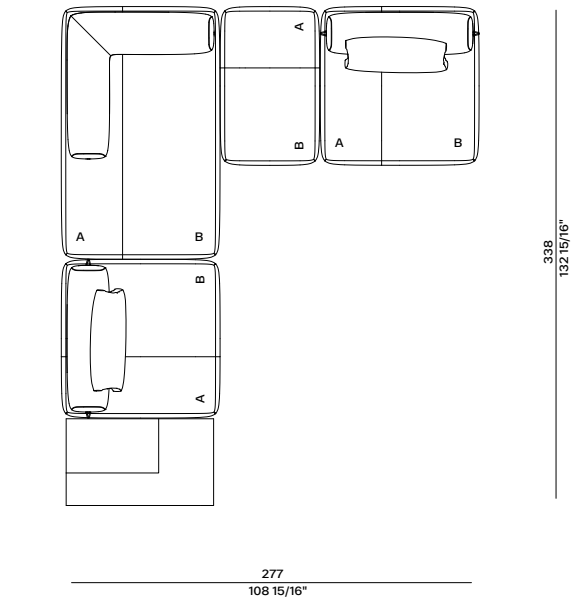

FP-013

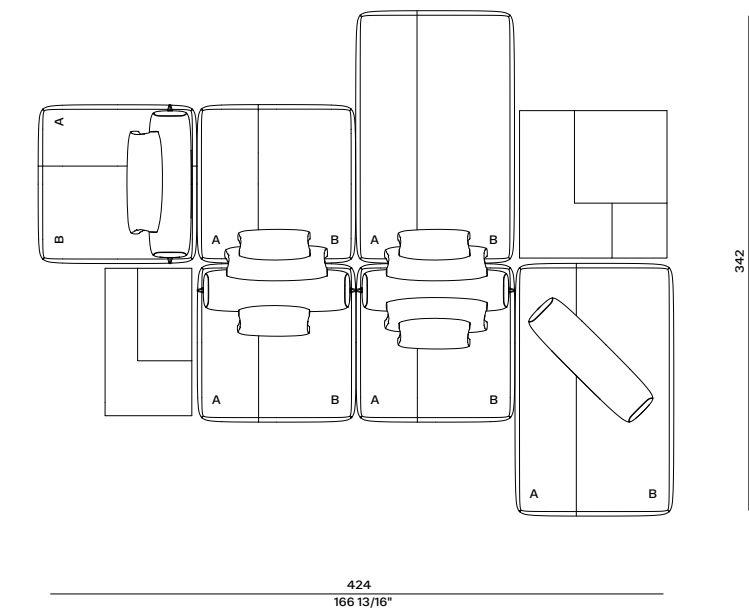



FENPEI COFFEE TABLES

MATERIALS

Base: meta
Top: wood

FINISHES

Base: bronze shadow matt finish
Top: burnished and hand-brushed olive ash



LABILIS MEGA RING SUSPENSION LAMP

MATERIALS

Structure: metal
Lighting body: matt bronzed brass, opal polycarbonate

FINISHES

Structure: varnished metal matt black RAL 9004



GIANO CHAIR

MATERIALS

Structure: wood
Upholstery: indoor fabrics

FINISHES

Structure: walnut stained ash
Upholstery: Fabrics cat. Superior, Deluxe, Leather, Nubuck

FENPEI COFFEE TABLE A

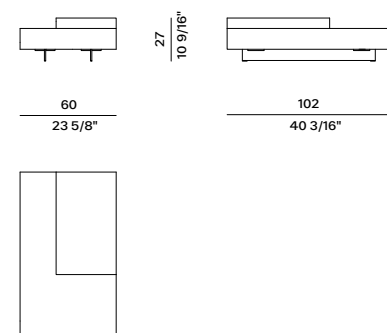

FENPEI COFFEE TABLE B

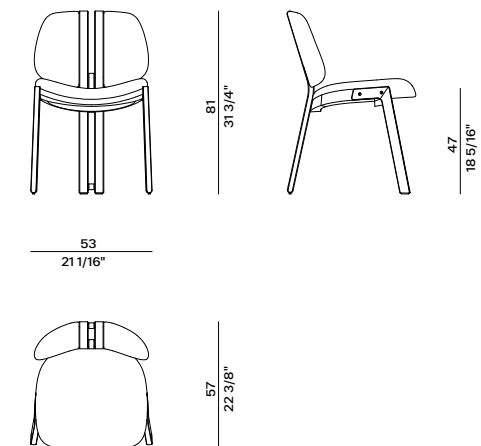
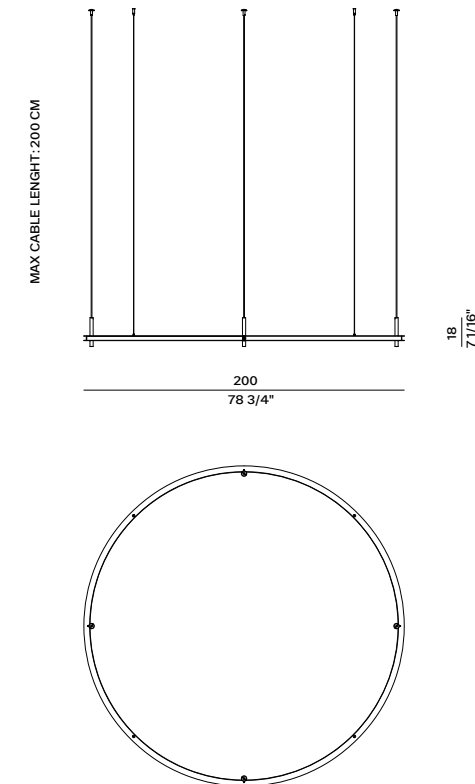
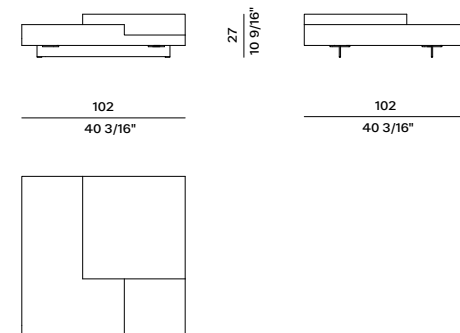



DIONE DARK TABLE

MATERIALS

Structure: metal
 Base: ceramic monolite ipergres (single-fired fine porcelain stoneware)
 Top: marble, brass

FINISHES

Structure: matt gold finish
 Base: glazed ceramic col. charcoal grey
 Top: Sahara Brown marble, matt gold finish

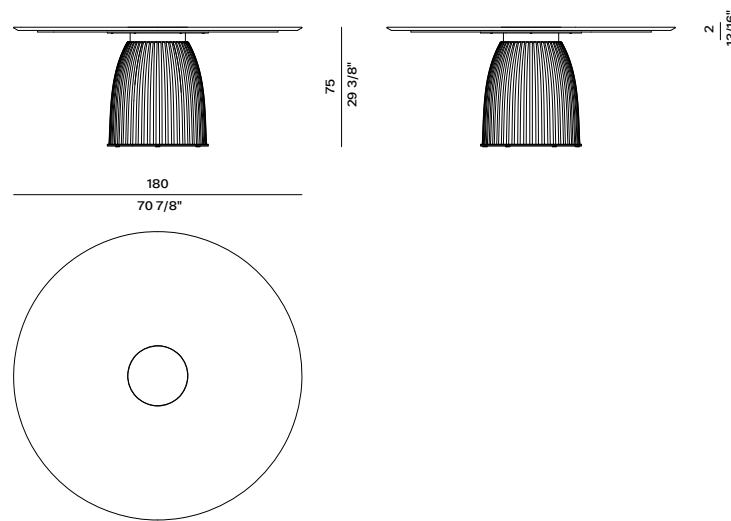

DIONE DARK COFFEE TABLE

MATERIALS

Structure: metal
 Base: ceramic
 Top: marble, metal

FINISHES

Structure: matt gold finish
 Base: 3D striped ceramic from Vietri col. charcoal grey
 Top: Sahara Brown marble, matt gold finish

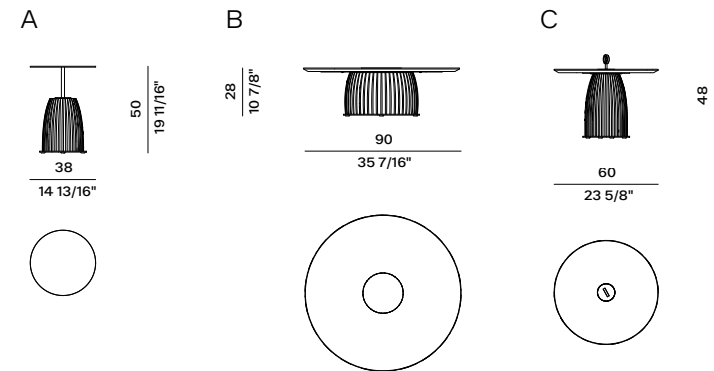

ILLUSIO SUSPENSION LAMP

MATERIALS

Structure: metal

FINISHES

Structure: varnished matt black RAL 9004 metal, polished brass

ILLUSIO SPIRAL SINGLE ELEMENT

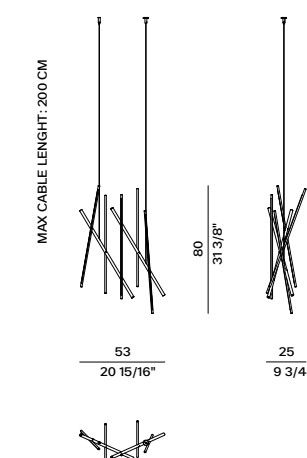

ILLUSIO SPIRAL COMPOSITION

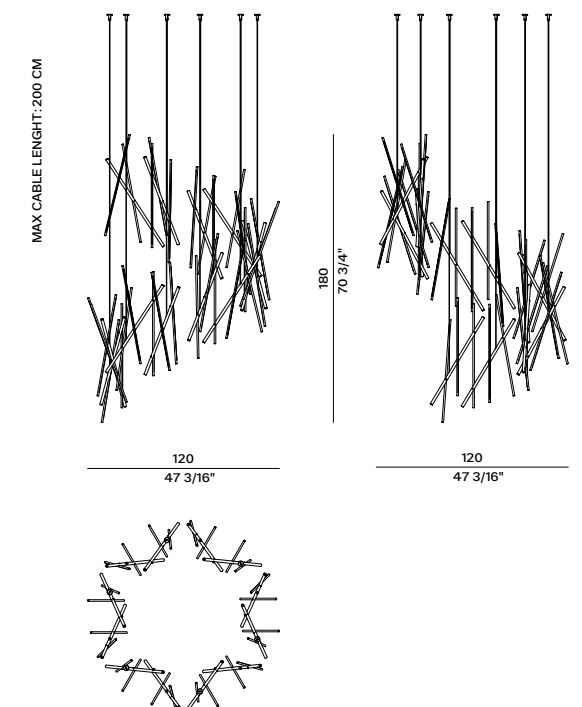



ILLUSIO WALL LAMP

MATERIALS
Structure: metal

FINISHES
Structure: varnished matt black RAL 9004 metal, polished brass

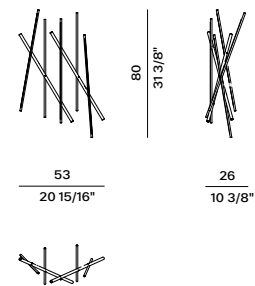

ELEGANCE SOFA

MATERIALS
Structure: wood
Upholstery: : indoor fabrics

FINISHES
Structure: laminated leather
Upholstery: Fabrics cat. Superior, Deluxe, Leather, Nubuck

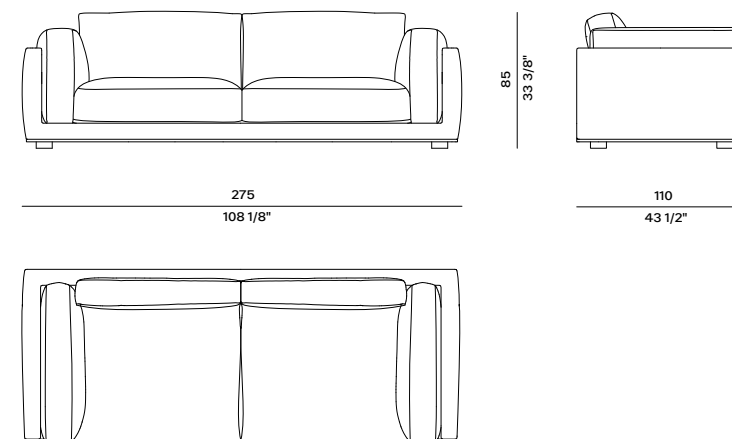

CRUDELIA ARMCHAIR

MATERIALS
Structure: wood, brass
Upholstery: indoor fabrics

FINISHES
Structure: : black stained ash, polished brass
Upholstery: Fabrics cat. Superior, Deluxe, Leather, Nubuck

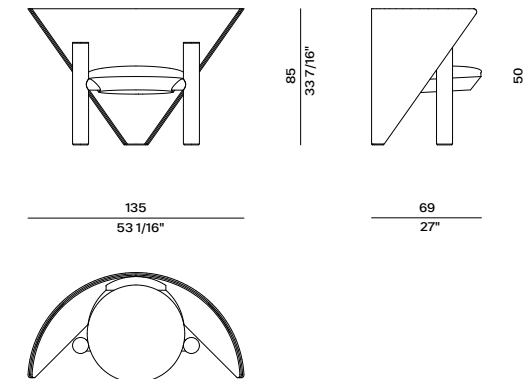

NUCLEO TABLE

MATERIALS
Base: metal, stone
Top: stone

FINISHES
Base: black calamine metal, Dolomia stone
Top: Dolomia stone

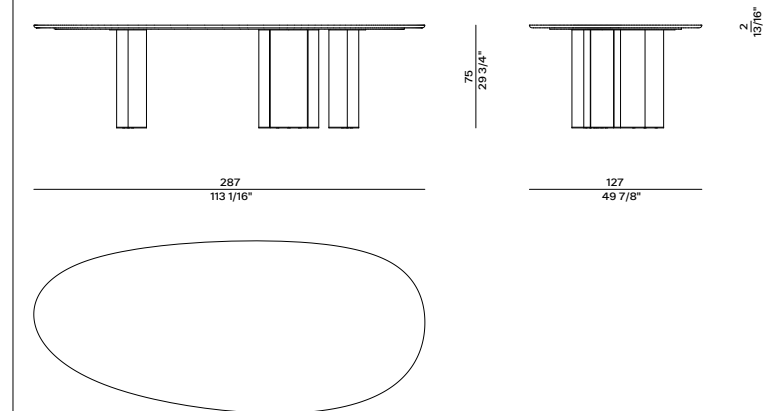



NUCLEO LOUNGE TABLES

MATERIALS

Base: metal, wood
Top: wood

FINISHES

Base: black calamine metal, lacquered wood
col. NCS S 6530G10Y
Top: lacquered wood col. NCS S 6530G10Y

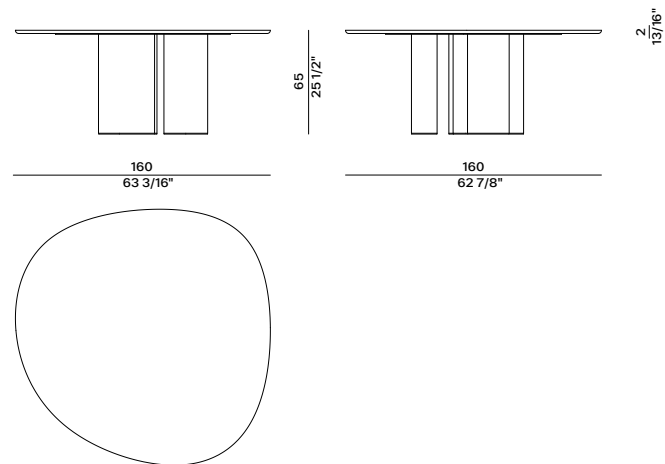

NUCLEO CONSOLE

MATERIALS

Base: metal, stone
Top: stone

FINISHES

Base: black calamine metal, Dolomia stone
Top: Dolomia stone

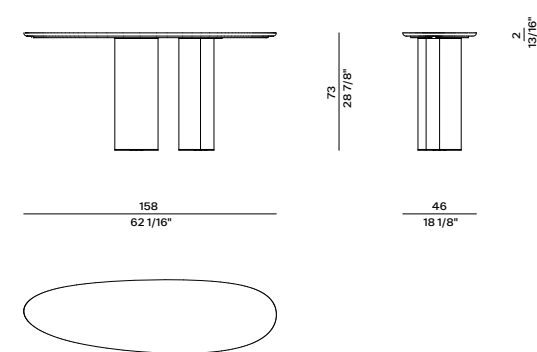

GONG

MATERIALS

Structure: metal
Body: glass

FINISHES

Structure: matt black varnished metal
Body: wavy bronzed glass

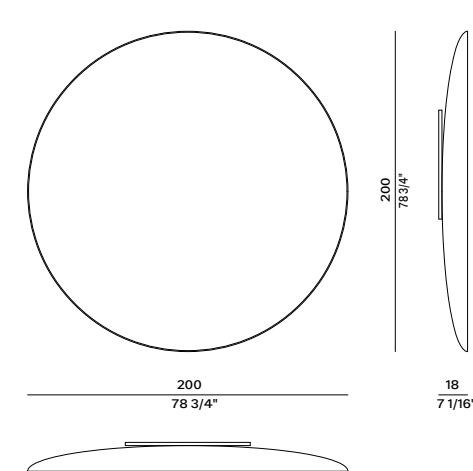

U CHAIR

MATERIALS

Base: metal
Upholstery: outdoor EVA

FINISHES

Base: painted finish RAL 7032,
painted finish NCS S3560-Y80R
Upholstery: col. Brick, col. Cream

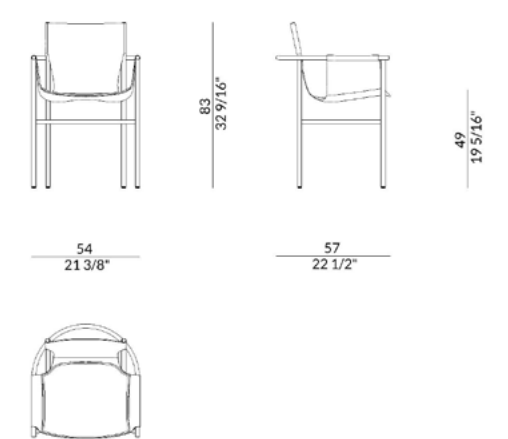



KENYA OUTDOOR TABLE

MATERIALS

Structure: metal
 Base: rigid polyurethane
 Top: stone

FINISHES

Structure: titanium stainless steel
 Base: travertine marble
 Top: travertine marble

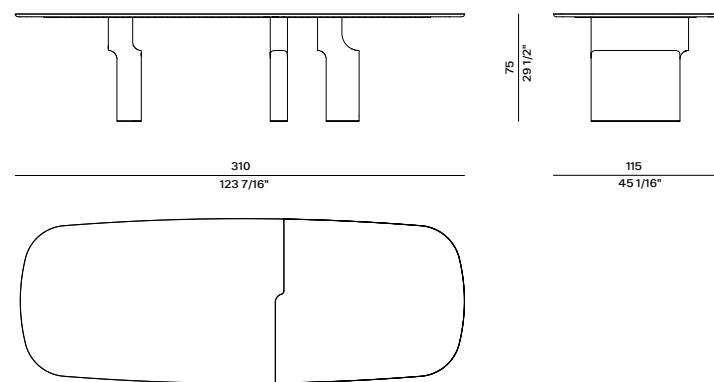

KENYA OUTDOOR CONSOLE

MATERIALS

Structure: metal
 Base: rigid polyurethane
 Top: stone

FINISHES

Structure: titanium stainless steel
 Base: travertine marble
 Top: travertine marble

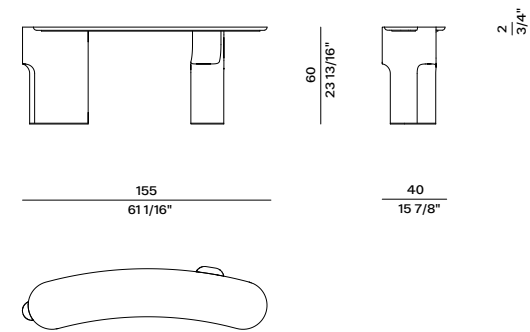

KENYA OUTDOOR COFFEE TABLES

MATERIALS

Structure: metal
 Base: rigid polyurethane
 Top: stone

FINISHES

Structure: titanium stainless steel
 Base: travertine marble
 Top: travertine marble

KENYA OUTDOOR COFFEE TABLE 90

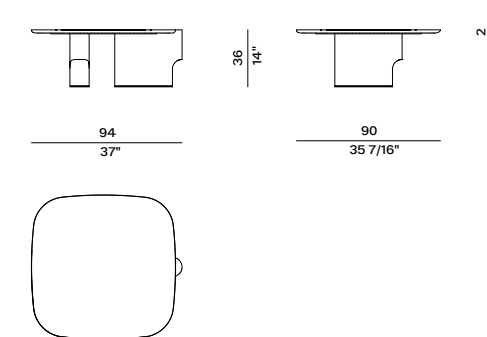

KENYA OUTDOOR COFFEE TABLE 45

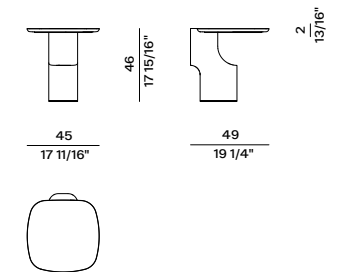



HAIBU SUSPENSION LAMP

MATERIALS

Structure: metal
Body: ceramic

FINISHES

Structure: stainless steel
Body: 3D printed natural fired gress

HAIBU SUSPENSION LAMP A

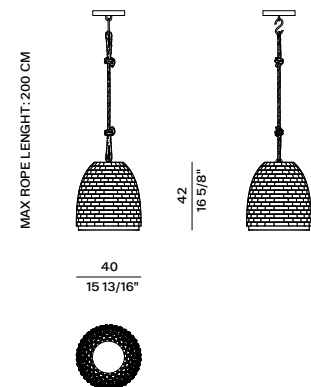

HAIBU SUSPENSION LAMP B

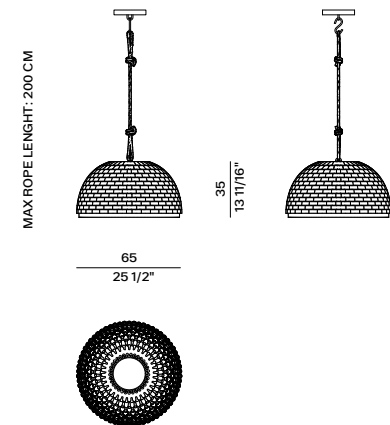

Paolo Castelli
Acquerello

Graphic design
LaTigre

Render
Paolo Castelli

Illustrations
Natalia Resmini

Print
Moderna Industrie Grafiche
April 2024



