

ALLA



PAOLO CASTELLI

SCERA



PAOLO CASTELLI

IT *L'esperienza manifatturiera a servizio dell'idea creativa, un codice estetico unico che va oltre le mode e che rivela i suoi caratteri in ogni particolare, collezione dopo collezione.*

Paolo Castelli S.p.A. è azienda italiana leader nel settore del design e del global contracting a livello nazionale e internazionale. Nata da un'intuizione di Paolo Castelli, l'azienda ha saputo coniugare tradizione e innovazione dando vita a collezioni indoor e outdoor "total look" sempre attuali in grado di raccontare la contemporaneità, anticipando le tendenze e rispondendo alle esigenze del mercato. Paolo Castelli S.p.A è in grado di soddisfare le esigenze dei progettisti e le richieste del cliente finale offrendo soluzioni custom made sviluppate intorno ai concetti di eccellenza e alta qualità: una visione dinamica che ha condotto l'azienda italiana a diventare il partner ideale per ambiziosi progetti contract, anche nel settore navale, in tutto il mondo.

EN *Manufacturing experience at the service of the creative idea, a unique aesthetic code that goes beyond fashion and reveals its character in every detail, collection after collection.*

Paolo Castelli S.p.A. is a leading Italian company in the design and global contracting sector at national and international level. Founded from an intuition of Paolo Castelli, the company has been able to combine tradition and innovation, giving life to always up-to-date indoor and outdoor "total look" collections capable of narrating contemporaneity, anticipating trends and responding to market needs. Paolo Castelli S.p.A is able to meet the needs of designers and the demands of the end customer by offering custom-made solutions developed around the concepts of excellence and high quality: a dynamic vision that has led the Italian company to become the ideal partner for ambitious contract projects, also in the naval sector, all over the world.

AMA CURVED SOFA, BERGERE,
OTTOMAN, GRAND POUF^{P.8}
BABOU LOUNGE CHAIR, POUF,
SYSTEM^{P.20} SARI CHAIR, LOUNGE
CHAIR^{P.22} ENSO CHAIR^{P.26}
ECHO BARSTOOL^{P.30} OTTOMANA^{P.32}
GRIETA TABLE^{P.34} KENYA TABLE,
CONSOLE, COFFEE TABLE^{P.38} DIONE
TABLE BISTROT^{P.46} ALBA TABLE BISTROT,
CONSOLE^{P.48} INFINITY MIRROR^{P.54}
FANUS SUSPENSION LAMP, FLOOR LAMP,
TABLE LAMP^{P.56} MANTA FLOOR LAMP,
TABLE LAMP^{P.60} ORIGAMI WALL LAMP^{P.64}
ABSTRACT CABINETS^{P.68}
TECHNICAL DATA^{P.77} THE RUGS^{P.93}

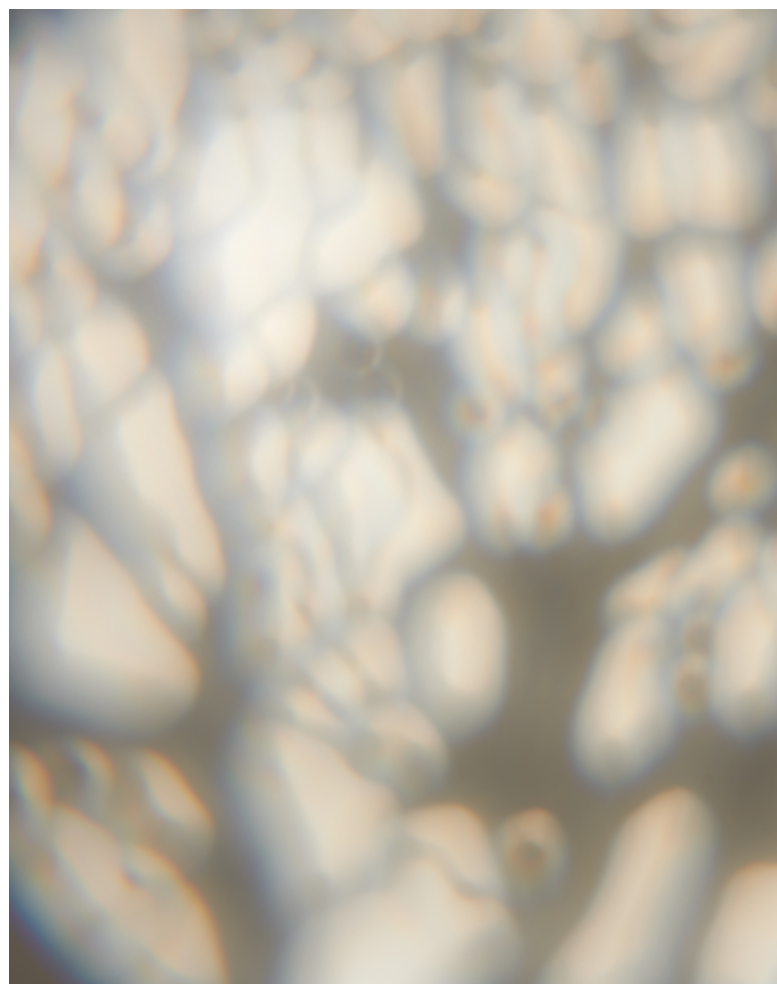

ALLA

SERA

THE COLLECTION

*“Forse perché della fatal quiete
Tu sei l’immagine, a me sì cara vieni,
O Sera!”*

Alla Sera, Ugo Foscolo

La sera giunge tra le mura domestiche nel suo silenzio immobile, permeando ogni ambiente di quiete e serenità. Si chiudono le porte, le luci si abbassano, gli arredi svelano il loro profilo nella penombra: tutto è pensato per rallentare il passo e recuperare il senso del proprio tempo. La nuova collezione 2023 “Alla sera” di Paolo Castelli nasce dalla volontà di armonizzare sensazioni distinte, dando vita ad un paesaggio romantico, che evoca l’atmosfera creata da un tramonto. Uno scenario suggestivo abitato da proposte indoor, outdoor e sistemi di illuminazione ad alta tecnologia e con un’anima artigianale che testimoniano l’abilità di Paolo Castelli di offrire un ampio catalogo di arredi per la zona giorno e per la zona notte.

Luci ed ombre si incontrano in una sinfonia di chiaro scuri esaltando cromie e matericità: un palcoscenico onirico dove le nuove proposte raccontano piccole storie di eleganza senza tempo.

*“Perhaps because of the final rest
You are the image, to me so dear you come
O Evening!”*

Alla Sera, Ugo Foscolo

EN Evening comes within the walls of the home in its still silence, permeating every room with stillness and serenity. The doors close, the lights dim, the furniture reveals its profile in the half-light: everything is designed to slow the pace and regain a sense of one’s own time. Paolo Castelli’s new 2023 collection “Alla Sera” (In the evening) originated from the desire to harmonise distinct sensations, giving life to a romantic landscape that evokes the atmosphere created by a sunset. An evocative scenario inhabited by indoor and outdoor proposals and high-tech lighting systems with a handcrafted soul that testify to Paolo Castelli’s ability to offer an extensive catalogue of furniture for the living and sleeping area.

Lights and shadows meet in a symphony of chiaroscuro enhancing colours and materiality: a dreamlike stage where the new proposals tell little stories of timeless elegance.

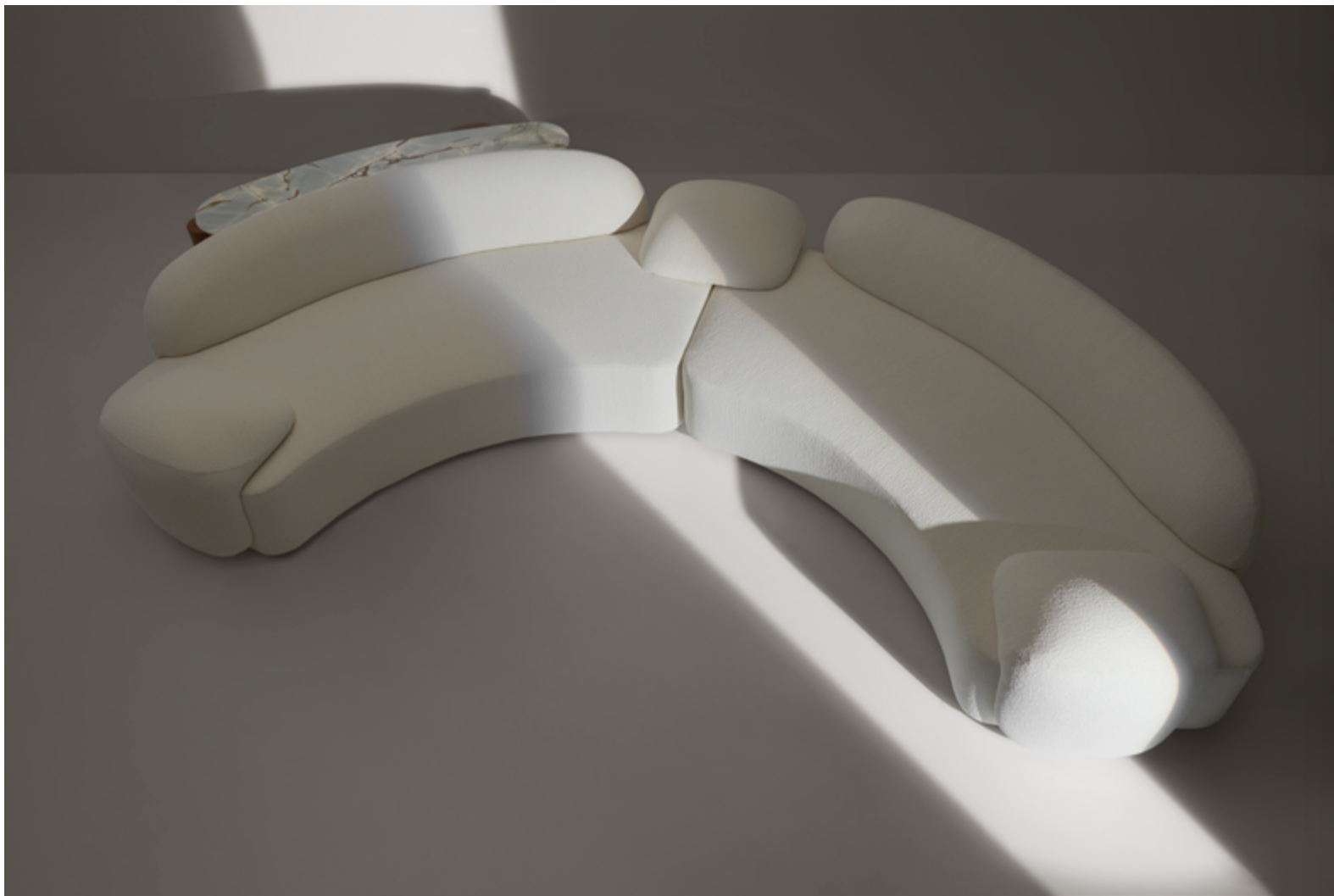

AMA CURVED SOFA, BERGERE, OTTOMAN, GRAND POUF

IT Una sensazione di grande accoglienza conferita dalle generose imbottiture e dai sofisticati dettagli che ammorbidiscono le geometrie. A seguito del successo riscosso dal divano, la famiglia Ama accoglie altre sedute imbottite quali la Bergere, il Grand Pouf, l'Ottoman, e la versione componibile anche con moduli curvi del divano omonimo. La collezione di sedute Ama si distingue per le asimmetrie create dalle diverse altezze e profondità degli elementi compositivi, l'ambiente viene animato così da un inaspettato dinamismo altamente scenografico.

EN A very cosy feeling given by the generous padding and sophisticated details that soften the geometries. Following the success of the sofa, the Ama family welcomes other upholstered seats such as the Bergere, the Grand Pouf, the Ottoman, and the modular version also with curved modules of the sofa of the same name. The Ama seating collection is distinguished by the asymmetries created by the different heights and depths of the compositional elements, the room is thus animated by an unexpected, highly scenic dynamism.





Ama curved
Manta suspension lamp

Kenya coffee table
Kenya console

Sari lounge chair
Mark carpet







IT Plaid in lana merino
EN Merino wool blanket





BABOU LOUNGE CHAIR, POUF, SYSTEM



IT Il logico si combina con l'irrazionale, le forme si uniscono in un gioco di opposti tra minimalismo ed esuberanza figurativa. Ispirata all'arte del pittore surrealista Salvador Dalí, la lounge chair Babou è caratterizzata dal disegno della sua struttura, completamente rivestita in laccio di cuoietto ecologico. Un elegante segno grafico che delinea lo schienale sostenendo la cuscineria, realizzata con poliuretano biologico. Nata per gli spazi esterni, arricchita da un avvolgente rivestimento in pelle outdoor, Babou è disponibile anche in versione indoor grazie all'ampia gamma di rivestimenti e colori disponibili. L'innata versatilità dell'arredo si svela nella versione priva di schienale, un pouf che grazie ad un semplice sistema di aggancio può unirsi alla lounge chair Babou dando vita ad una nuova composizione, un sistema modulare che risponde a tutte le esigenze estetiche e di spazio.

EN The logical is combined with the irrational, forms come together in a play of opposites between minimalism and figurative exuberance. Inspired by the art of the surrealist painter Salvador Dalí, the Babou lounge chair is characterised by the design of its frame, which is completely upholstered in ecological cuoietto leather lace. An elegant graphic sign outlines the backrest supporting the cushioning, made of organic polyurethane. Created for outdoor spaces, enriched with an enveloping outdoor leather upholstery, Babou is also available in an indoor version thanks to the wide range of coverings and colours available. The furniture's innate versatility is revealed in the backless version, a pouf that thanks to a simple coupling system can join the Babou lounge chair, creating a new composition, a modular system that meets all aesthetic and space requirements.





SARI CHAIR, LOUNGE CHAIR

IT Gradevolezza estetica ed ergonomia si uniscono in una seduta dalla silhouette audace in ogni dettaglio. Composta da una struttura interna in metallo, Sari si distingue per l'imbottitura in poliuretano espanso, che avvolge il sedile, lo schienale e le gambe determinando il tratto distintivo dell'arredo. Come il sari avvolge il corpo femminile esaltandone le linee sinuose, così l'arco in legno tornito in massello di frassino tinto noce, che sembra sostenere sia la sedia che la lounge chair, celebra il dinamismo creando un movimento curvilineo.

Sari reinventa il concetto di comfort grazie al design eclettico e all'aspetto accogliente e morbido delle sue componenti.

EN Aesthetic appeal and ergonomics come together in a seat with a bold silhouette in every detail.

Composed of a metal inner structure, Sari is distinguished by its polyurethane foam upholstery, which envelops the seat, back and legs and determines the distinctive feature of the furniture. Just as the sari envelops the female body, enhancing its sinuous lines, so the solid walnut-stained ash-turned wood arch, which seems to support both chair and lounge chair, celebrates dynamism by creating a curvilinear movement.

Sari reinvents the concept of comfort with its eclectic design and the cosy, soft appearance of its components.



Black and Gold Cabinet
Manta table lamp

Manta floor lamp
Manta suspension lamp

Sari lounge chair
Petra bookcase

Kenya console
Ama curved

Mark carpet



ENSO CHAIR



IT Un ritorno all'essenzialità del progetto, una seduta che reinventa un arredo classico grazie alla combinazione di forme geometriche semplici esaltate da scelte cromatiche e texture a contrasto.

Composta da una struttura in legno a vista, la sedia Enso utilizza una calibrata sovrapposizione di cerchi, da cui prende il nome, come schienale, diventando un affascinante proposta per spazi residenziali e contract dal gusto ricercato. Enso è una seduta dal design avvolgente che esprime in ogni particolare la cura per il dettaglio dell'azienda.

EN A return to the essentiality of design, a seat that reinvents a classic piece of furniture thanks to the combination of simple geometric shapes enhanced by contrasting colour choices and textures.

Composed of an exposed wooden frame, the Enso chair uses a calibrated overlapping of circles, from which it takes its name, as a backrest, making it a fascinating proposition for residential and contract spaces with refined taste. Translation Enso is a seat with an enveloping design that expresses the company's attention to every detail.



Kenya table
Enso chair

Fanus suspension lamp
Vasilij carpet





ECHO HIGH BARSTOOL, LOW BARSTOOL

IT Una dichiarazione d'amore a Bologna, una famiglia di sedute dall'animo romantico caratterizzate dallo schienale ad arco omaggio ai celebri porticati della città. Echo è una collezione dalle proporzioni calibrate che si distingue per il contrasto tra la struttura minimale in legno multistrato curvato e le forme generose degli elementi imbottiti. Lo sgabello, proposto in due diverse altezze, rappresenta un interessante ampliamento a catalogo, una soluzione ideale e dal grande impatto visivo capace di arredare sia ambienti privati che lussuosi spazi contract.

EN A declaration of love to Bologna, a family of chairs with a romantic soul characterised by their arched backrests paying homage to the city's famous porticoes. Echo is a collection with calibrated proportions that stands out for the contrast between the minimalist structure in curved plywood and the generous shapes of the upholstered elements. The stool, offered in two different heights, represents an interesting addition to the catalogue, an ideal solution with great visual impact capable of furnishing both private and luxurious contract spaces.



OTTOMANA



IT Un'apparente semplicità caratterizza Ottomana, uno sgabello raffinato che abita gli spazi con disinvoltura fungendo anche da coffee table o oggetto decorativo. Il design compatto risulta delicato alla vista grazie alla forma minimale e avvolgente del sedile che rende l'arredo iconico. Realizzato in ceramica smaltata a mano e disponibile in nuove finiture, Ottomana è una soluzione ideale per arredare gli ambienti indoor e outdoor anche singolarmente.

EN An apparent simplicity characterizes Ottomana, a refined stool that inhabits spaces with ease while also serving as a coffee table or decorative object. The compact design is delicate to the eye thanks to the minimal, enveloping shape of the seat that makes the furniture iconic. Made of hand-glazed ceramic and available in new finishes, Ottomana is an ideal solution for furnishing indoor and outdoor spaces even individually.





GRIETA TABLE

IT Un tavolo funzionale dalle forme essenziali che rivela la sua poetica nell'intervento artistico. Traduzione in spagnolo della parola fenditura, Grieta rende le interruzioni di continuità un'occasione per intraprendere un nuovo percorso alla scoperta delle potenzialità della ceramica, materiale con cui è realizzato. Caratterizzato da una base a forma di campana dalla superficie irregolare, disponibile in ceramica smaltata o pietra vicentina, il tavolo Grieta rappresenta un palcoscenico contemporaneo per la condivisione, una soluzione sofisticata che abita la zona dining con disinvoltura grazie al disegno pulito ed essenziale del piano d'appoggio.

EN A functional table with essential forms that reveals its poetics in the artistic intervention. A Spanish translation of the word 'cleft', Grieta makes interruptions in continuity an opportunity to embark on a new journey to discover the potential of ceramics, the material from which it is made. Characterised by a bell-shaped base with an irregular surface, available in glazed ceramic or Vicenza stone, the Grieta table represents a contemporary stage for sharing, a sophisticated solution that inhabits the dining area with ease thanks to the clean and essential design of the table top.

Grieta table
Sari chair

Stellantis suspension lamp
Fair light

Ottomana
Uffizio bookcase

Paul carpet



*KENYA TABLE, CONSOLE,
COFFEE TABLE*



IT Le venature del legno incontrano quelle del marmo disegnando nuovi percorsi. Si delinea sulle superfici una trama irregolare in grado di evocare paesaggi naturali ed incontaminati. Kenya è una famiglia di arredi dal forte carattere architettonico, una proposta completa per la zona living e dining composta da tavolo, console e coffee table. I volumi sottratti che caratterizzano la struttura di ciascun elemento si uniscono al piano d'appoggio rettangolare, conferendo alla collezione un aspetto inusuale che rende omaggio all'asimmetria. L'incontro materico tra le gambe in legno e il top in marmo caratterizzano ogni elemento, animando il profilo minimale con dettagli ricercati.

EN Wood grains meet marble veins, drawing new paths. An irregular texture is outlined on the surfaces, evoking natural, unspoiled landscapes. Kenya is a furniture family with a strong architectural character, a complete proposal for the living and dining area consisting of table, console and coffee table. The subtracted volumes that characterise the structure of each element combine with the rectangular table top, giving the collection an unusual appearance that pays homage to asymmetry. The material encounter between the wooden legs and the marble top characterises each element, animating the minimal profile with sophisticated details.







Kenya console
Kenya coffee table

Ama curved



Kenya coffee table
Manta suspension lamp

Sari lounge chair
Mark carpet



DIONE TABLE BISTROT



IT Un delicato equilibrio di composizioni materiche, una proposta in grado di dialogare con diversi stili di arredamento aggiungendo un tocco di eleganza agli ambienti. La collezione Dione si caratterizza per le forme scultoree del top disponibile in marmo Calacatta e White Silk opaco che dialogano con la base statuarica realizzata in ceramica. La famiglia Dione, composta da una serie di coffee table di diverse dimensioni, accoglie una nuova versione del tavolo dal top rotondo ancora più spazioso dal diametro di 100 cm.



EN A delicate balance of material compositions, a proposal capable of communicating with different furnishing styles, adding a touch of elegance to rooms. The Dione collection is characterised by the sculptural forms of the top available in Calacatta marble and matt White Silk that dialogues with the statuesque base made of ceramic. The Dione family, consisting of a series of coffee tables in different sizes, welcomes a new version of the table with an even more spacious round top with a diameter of 100 cm.



ALBA @NSOLE, TABLE BISTROT

IT Una scelta sofisticata per una zona giorno personalizzata in ogni dettaglio, una collezione che conduce il minimalismo verso il decoro. Disponibili con top rotondo e rettangolare, il tavolo e la console Alba nascono dall'incontro di finiture e forme diverse che conferiscono alla famiglia di arredi un'identità ben definita in cui la forza espressiva dei materiali esalta le singole lavorazioni. La collezione Alba trova infatti il suo segno distintivo nell'incontro tra il cerchio e il cilindro che costituiscono il punto di congiunzione tra la base e il top, un elegante dettaglio tecnico estetico che eleva l'intera figura.

EN A sophisticated choice for a living area personalised in every detail, a collection that leads minimalism towards decoration. Available with round and rectangular tops, the Alba table and console are the result of a combination of different finishes and shapes that give the furniture family a clearly defined identity in which the expressive power of the materials enhances the individual workmanship. In fact, the Alba collection finds its hallmark in the meeting of the circle and the cylinder that form the junction between the base and the top, an elegant technical aesthetic detail that elevates the entire figure.





INFINITY MIRROR



IT Una specchiera dai profili tondeggianti retroilluminata nata per creare uniche riflessioni di design. Infinity reinventa in chiave contemporanea il concetto di specchio trasformandolo da oggetto semplice e funzionale, ad arredo ornamentale. I profili in Nichel nero opaco si liberano dai vincoli perimetrali della cornice dando vita ad un gioco di prospettiva per cui lo specchio sembra protendersi all'infinito, illuminando e decorando il muro che la ospita.

EN A mirror with rounded contours backlit to create unique design reflections. Infinity reinvents the mirror concept in a contemporary key, transforming it from a simple and functional object to an ornamental piece of furniture. The matt black nickel profiles are freed from the perimeter constraints of the frame, creating a play on perspective whereby the mirror seems to stretch out into infinity, illuminating and decorating the wall that houses it.

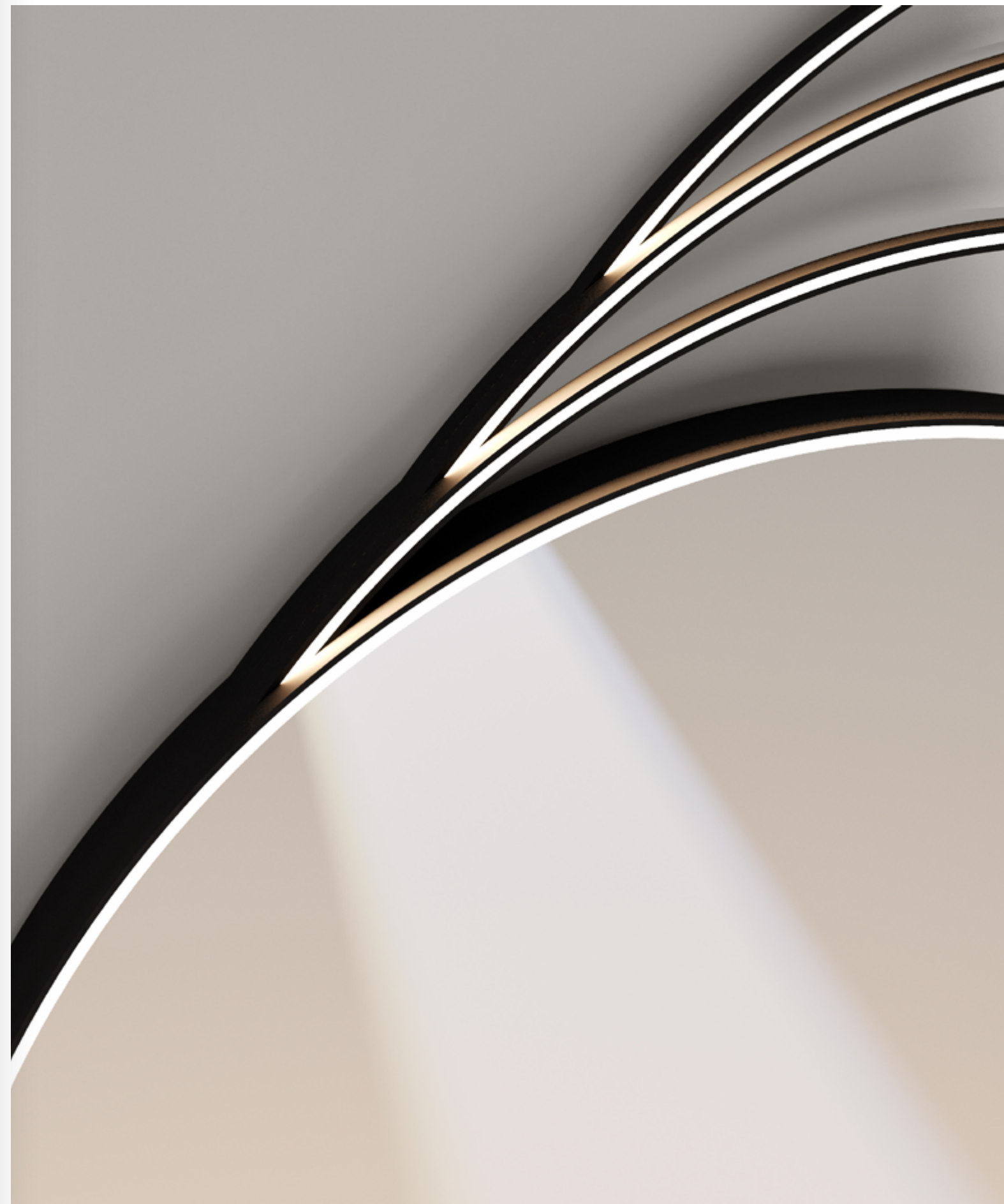

FANUS SUSPENSION LAMP, FLOOR LAMP, TABLE LAMP



IT Una lampada pensata per illuminare lo spazio e regalare l'intimità dell'ombra. Alimentata da una sorgente di luce a led, Fanus reinterpreta il concetto di lanterna, distinguendosi per il corpo centrale illuminante realizzato in vetro cannettato trasparente e per il paralume disponibile in tessuto o in vetro di Murano. Dettagli in cuoietto naturale impreziosiscono l'intera figura, rendendo Fanus un progetto fortemente contemporaneo, disponibile a sospensione, da terra e nella versione da tavolo con cavo e batteria.

EN A lamp designed to illuminate space and provide the intimacy of shade. Powered by a led light source, Fanus reinterprets the concept of the lantern, distinguished by a central illuminating body made of transparent canneted glass and a lampshade available in fabric or Murano glass. Natural cuoietto leather details embellish the entire figure, making Fanus a highly contemporary design, available in a pendant, floor and table version with cable and battery.



Kenya table
Fanus suspension lamp

Enso chair
Vasilij carpet



Ama bergere
Ama armchair

Fanus floor lamp
Imperfect coffee table

Abstract high cabinet
Murano vase

Piet carpet





*MANTA SUSPENSION LAMP,
FLOOR LAMP, TABLE LAMP*

IT Piegare la materia all'arte, una lampada che assume le sembianze di una foglia che volteggia leggera nell'ambiente. La famiglia di lampade Manta accoglie le versioni da terra e da tavolo, ampliando la proposta di sistemi di illuminazione caratterizzati da un'eterea leggerezza e sobria eleganza. La sorgente di luce a led, una raffinata foglia in vetro color Fume o ambra, forgiata a mano dai maestri vetrai di Murano, illumina l'ambiente con grande calore e naturalezza, dando vita ad un'atmosfera avvolgente e di assoluta armonia.

EN Bending matter to art, a lamp that takes on the appearance of a leaf that twirls lightly in the room. The Manta family of lamps welcomes floor and table versions, expanding the range of lighting systems characterised by ethereal lightness and understated elegance. The led light source, a refined Fume or amber coloured glass leaf, hand-forged by master glassmakers in Murano, illuminates the room with great warmth and naturalness, creating an enveloping atmosphere of absolute harmony.





ORIGAMI WALL LAMP

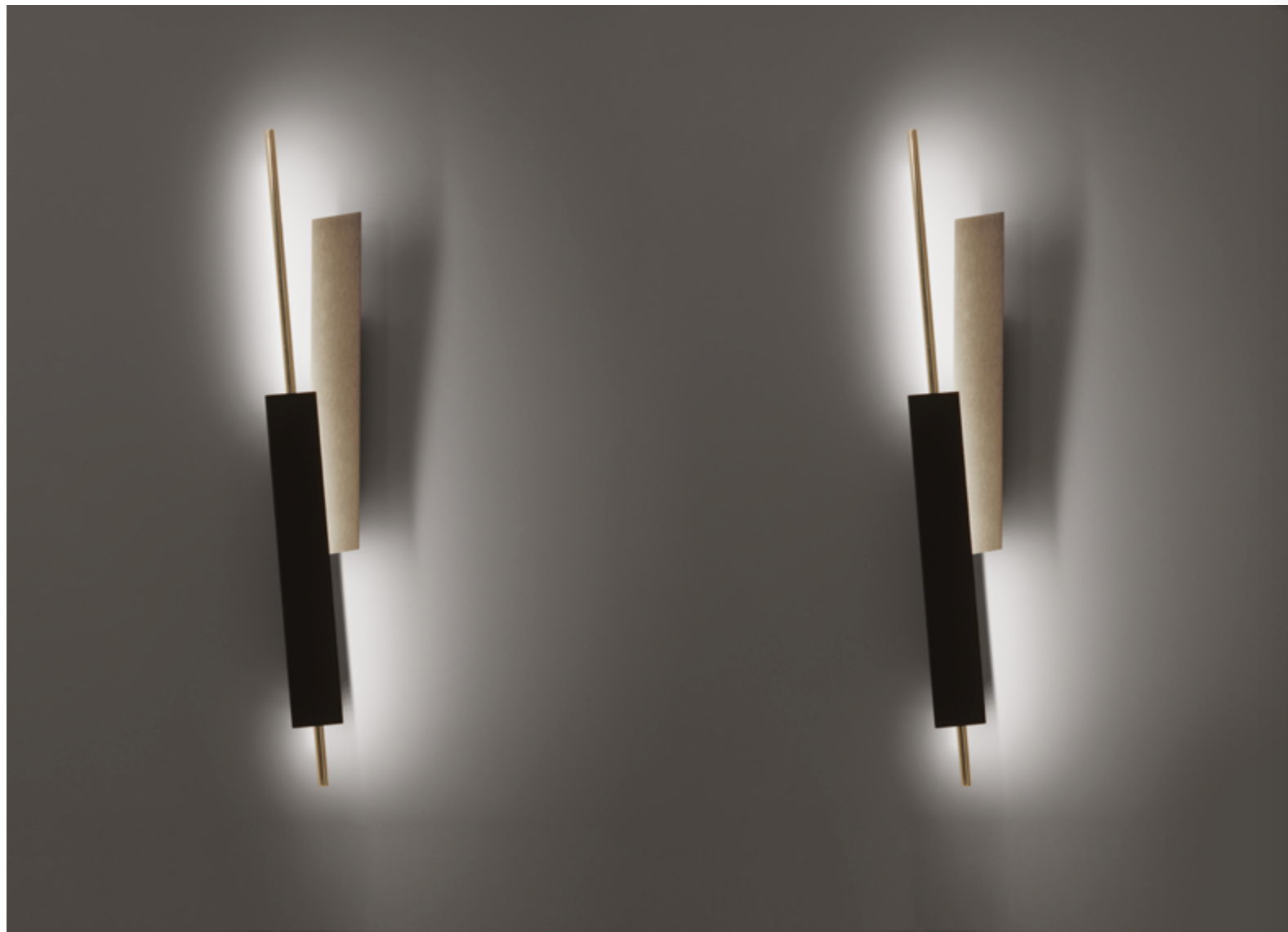

IT Una bellezza sottile, una luce piena e mai invadente che illumina l'ambiente evocando atmosfere lontane.

La lampada a parete Origami, si contraddistingue per il tratto contemporaneo e longilineo delle sue singole componenti formate ognuna da due elementi: la struttura in doppia finitura, oro opaco satinato e nero opaco, viene attraversata da un'asta in ottone contenente la sorgente di luce a led.

Combinati tra loro, i raggi formano un ventaglio di luce che anima lo spazio donando movimento alla parete. La particolarità del suo design, permette ad Origami di dare vita a molteplici composizioni grafiche, rivelando il suo carattere fortemente decorativo, anche a luci spente.

EN A subtle beauty, a full and never intrusive light that illuminates the room, evoking distant atmospheres.

The Origami wall lamp is characterised by the contemporary and long-linear design of its individual components, each consisting of two elements: the structure in a double finish, satin matt gold and matt black, is crossed by a brass rod containing the led light source.

Combined, the beams form a fan of light that animates the space, giving movement to the wall. The uniqueness of its design allows Origami to create multiple graphic compositions, revealing its highly decorative character, even when the lights are off.



Kenya table
Enso chair

Socrate bookcase
Fanus table lamp

Fanus suspension lamp
Origami wall lamp

Abstract low cabinet
Accra A cache-pot

Vasilij carpet





*ABSTRACT LOW @BINET,
HIGH @BINET*

IT Un'interazione contraddittoria tra design minimalista e dinamici decori astratti. I contenitori giorno Abstract in legno frassino tinto noce si distinguono per le ante rivestite con preziose lamiere in ottone decorate a mano. La particolarità risiede nelle due lavorazioni differenti del materiale che creano profondità attraverso i movimenti sinuosi delle forme, elemento ripreso anche per i dettagli dei piedini sottili e curvi che sostengono la base. Caratterizzato da un top in vetro restrolaccato, Abstract è disponibile in diverse versioni, rappresentando una soluzione dal design versatile e accattivante per ambiziosi progetti interior.

EN A contradictory interaction between minimalist design and dynamic abstract décors. Abstract day storage units in walnut-stained ash wood are distinguished by doors covered with precious hand-decorated brass plates. The distinctiveness lies in the two different workings of the material that create depth through the sinuous movements of the shapes, an element that is also echoed in the details of the slender, curved feet that support the base. Featuring a back-lacquered glass top, Abstract is available in several versions, representing a versatile and attractive design solution for ambitious interior projects.



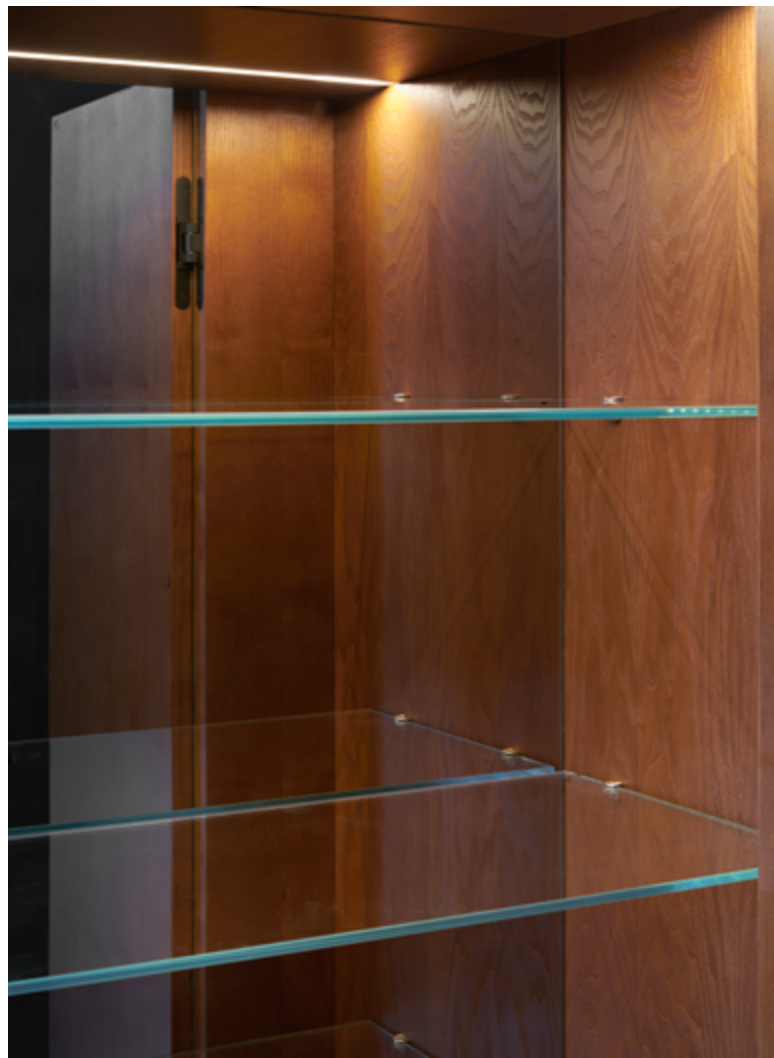

Abstract high cabinet
Kenya console

Ama bergere
Ama armchair

Fanus floor lamp
Fanus suspension lamp

Enso chair
Piet carpet



*TECHNICAL
DATA*



AMA CURVED

MATERIALS

Structure: wood
Upholstery: indoor fabrics

FINISHES

Upholstery: Fabrics Cat. Superior, Deluxe, Eco-friendly
Leather TOP, Bovine leather, Nubuck

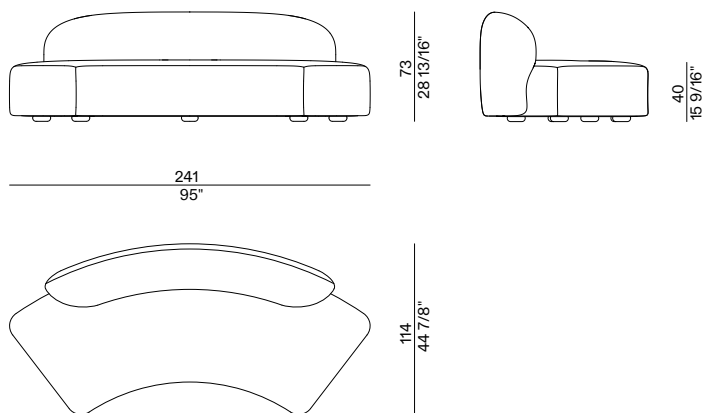

AMA SOFA

MATERIALS

Structure: wood
Upholstery: indoor fabrics

FINISHES

Upholstery: Fabrics Cat. Superior, Deluxe, Eco-friendly
Leather TOP, Bovine leather, Nubuck

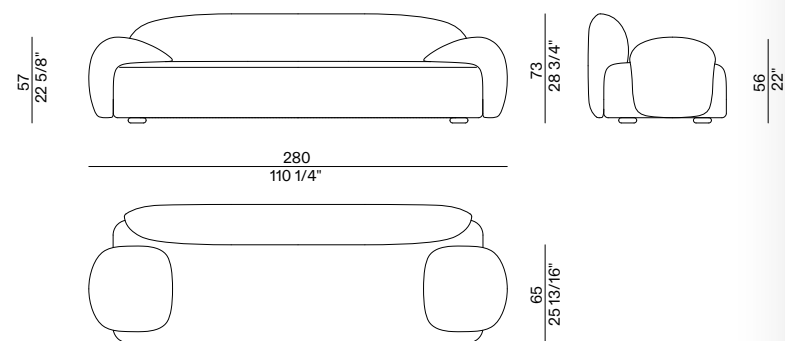

AMA ARMCHAIR

MATERIALS

Structure: wood
Upholstery: indoor fabrics

FINISHES

Upholstery: Fabrics Cat. Superior, Deluxe, Eco-friendly
Leather TOP, Bovine leather, Nubuck

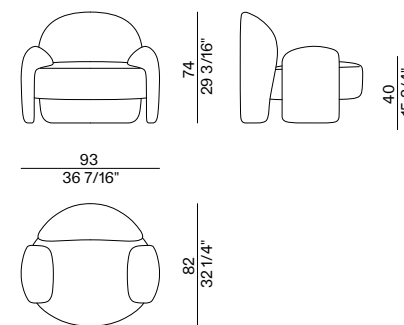

AMA BERGERE, OTTOMAN

MATERIALS

Structure: wood
Upholstery: indoor fabrics

FINISHES

Upholstery: Fabrics Cat. Superior, Deluxe, Eco-friendly
Leather TOP, Bovine leather, Nubuck

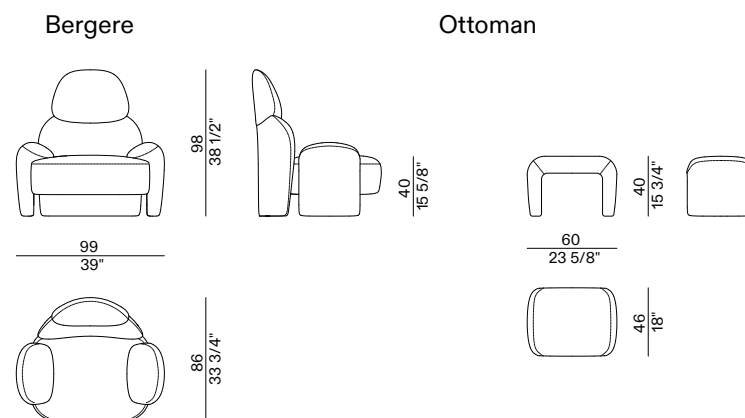



AMA GRAND POUF

MATERIALS

Structure: wood
Upholstery: indoor fabrics

FINISHES

Upholstery: Fabrics Cat. Superior, Deluxe, Eco-friendly
Leather TOP, Bovine leather, Nubuck

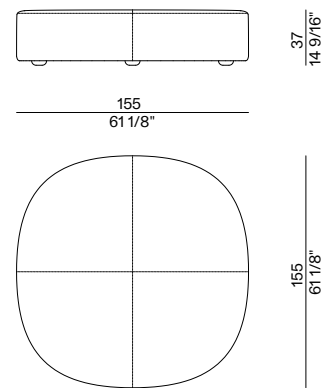

BABOU LOUNGE CHAIR

MATERIALS

Structure: stainless steel
Upholstery: fabrics cat. outdoor, indoor fabrics

FINISHES

Structure: painted and covered in outdoor leather
Upholstery: Fabrics cat. Outdoor, Superior, Deluxe,
Eco-Friendly leather TOP, Bovine leather, Nubuck

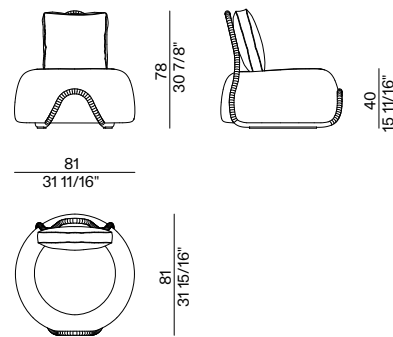

BABOU POUF

MATERIALS

Structure: stainless steel
Upholstery: fabrics cat. outdoor, indoor fabrics

FINISHES

Structure: painted and covered in outdoor leather
Upholstery: Fabrics cat. Outdoor, Superior, Deluxe,
Eco-Friendly leather TOP, Bovine leather, Nubuck

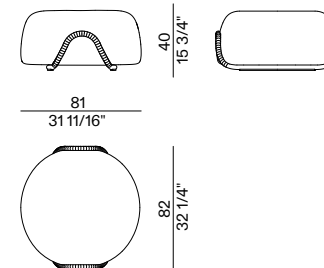

BABOU SYSTEM

MATERIALS

Structure: stainless steel
Upholstery: fabrics cat. outdoor, indoor fabrics

FINISHES

Structure: painted and covered in outdoor leather
Upholstery: Fabrics cat. Outdoor, Superior, Deluxe,
Eco-Friendly leather TOP, Bovine leather, Nubuck

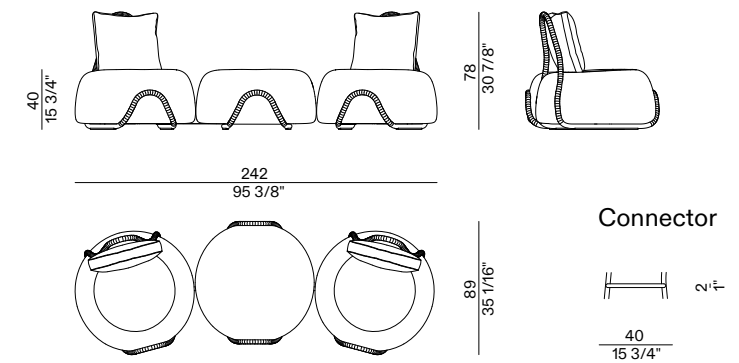



SARI CHAIR

MATERIALS

Structure: iron, wood
 Upholstery: indoor fabrics

FINISHES

Structure: walnut stained ash
 Upholstery: Fabrics cat. Superior, Deluxe, Eco-Friendly
 leather TOP, Bovine leather, Nubuck

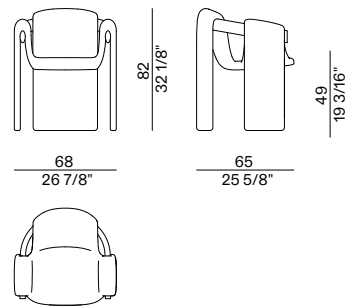

SARI LOUNGE

MATERIALS

Structure: iron, wood
 Upholstery: indoor fabrics

FINISHES

Structure: walnut stained ash
 Upholstery: Fabrics cat. Superior, Deluxe, Eco-Friendly
 leather TOP, Bovine leather, Nubuck

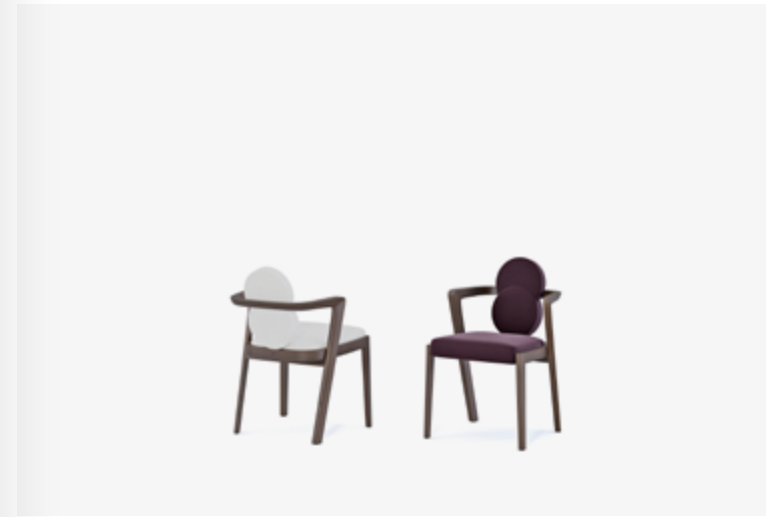
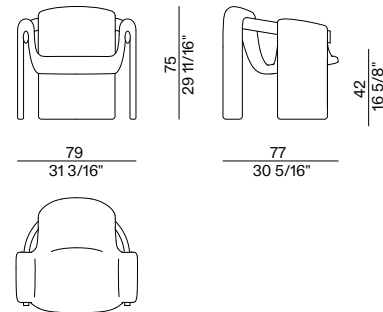

ENSO CHAIR

MATERIALS

Structure: wood
 Upholstery: indoor fabrics

FINISHES

Structure: walnut stained ash, bleached ash, dark stained ash
 Upholstery: Fabrics cat. Superior, Deluxe, Eco-Friendly
 leather TOP, Bovine leather, Nubuck

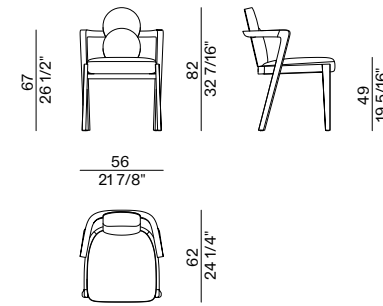

ECHO BARSTOOL

MATERIALS

Structure: wood
 Upholstery: indoor fabrics

FINISHES

Structure: walnut stained ash, bleached ash, dark stained ash
 Upholstery: Fabrics cat. Superior, Deluxe, Eco-friendly
 Leather TOP, Bovine leather, Nubuck

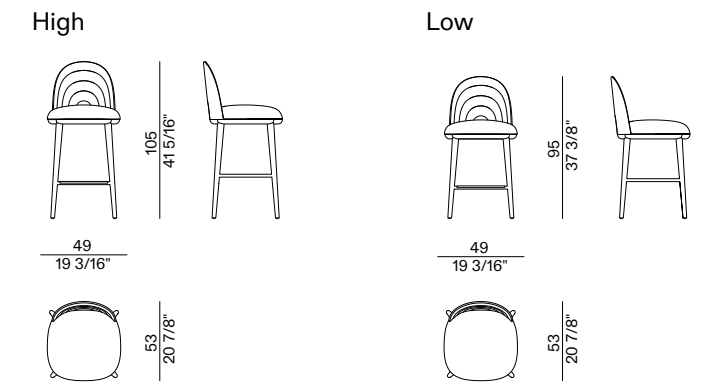



OTTOMANA

MATERIALS

Base: single-fired fine porcelain stoneware, monolite ipergres
 Seating: single-fired fine porcelain stoneware, monolite ipergres

FINISHES

Base and seating: col. Sage, Terracotta, Ocean, Platinum or Gold

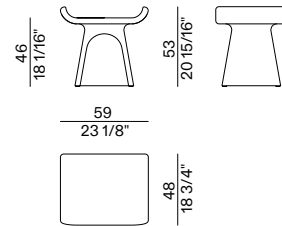

GRIETA TABLE

MATERIALS

Base: single-fired fine porcelain stoneware, monolite ipergres or stone
 Top: ceramic
 Under-top: MDF

FINISHES

Base: ceramic col. Sage, Terracotta, Ocean, Grey or Vicenza stone col. Ivory or col. Light grey
 Top: col. Sage, Terracotta, Ocean, Grey
 Under-top: glossy lacquered in matching colour

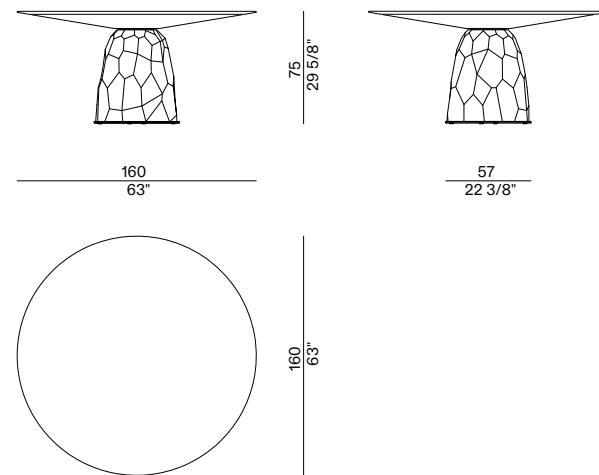

KENYA RECTANGULAR TABLE

MATERIALS

Base: wood
 Top: marble, wood

FINISHES

Base: walnut-painted ash, bleached ash, dark painted ash
 Top: marbles, natural stones, reconstituted stones

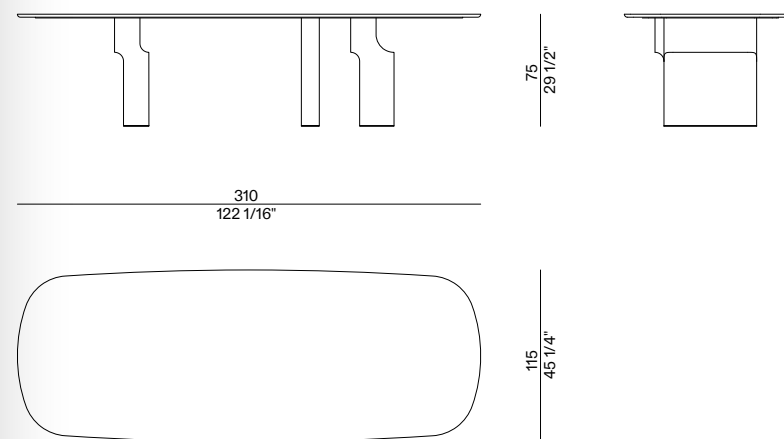

KENYA CONSOLE

MATERIALS

Base: wood
 Top: marble, wood

FINISHES

Base: walnut-painted ash, bleached ash, dark painted ash
 Top: marbles, natural stones, reconstituted stones

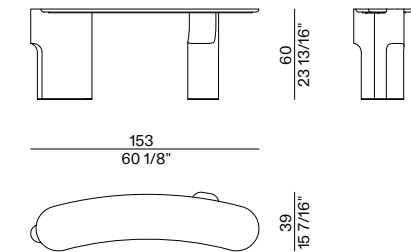



KENYA COFFEE TABLES

MATERIALS

Base: wood
Top: marble, wood

FINISHES

Base: walnut-painted ash, bleached ash, dark painted ash
Top: marbles, natural stones, reconstituted stones



DIONE TABLE BISTROT

MATERIALS

Structure: metal
Top: marble
Base: ceramic

FINISHES

Structure: Gold matt finish
Top: Calacatta, White Silk
Base: 3d ceramic



ALBA TABLE BISTROT

MATERIALS

Structure: metal
Top: stone
Base: stone

FINISHES

Structure: bronze shadow matt finish
Top: Vicenza stone honed col. Ivory
Base: Vicenza stone honed col. Ivory



ALBA CONSOLE

MATERIALS

Structure: metal
Top: stone
Base: stone

FINISHES

Structure: bronze shadow matt finish
Top: Vicenza stone honed col. Ivory
Base: Vicenza stone honed col. Ivory

CT 90

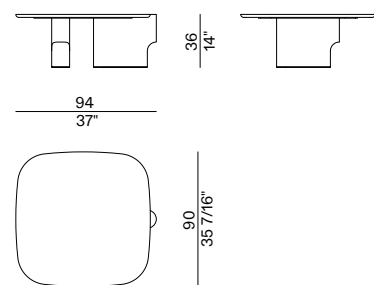

CT 45

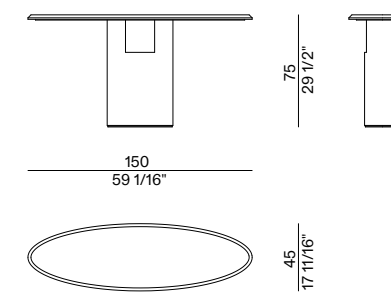
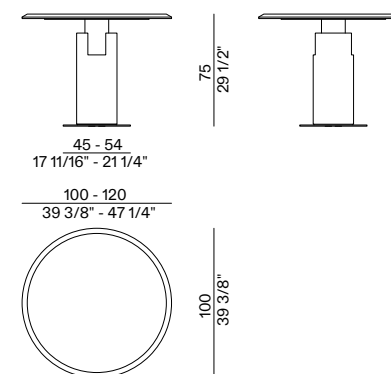
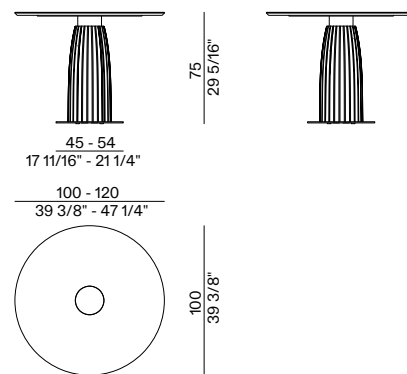
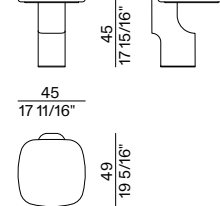

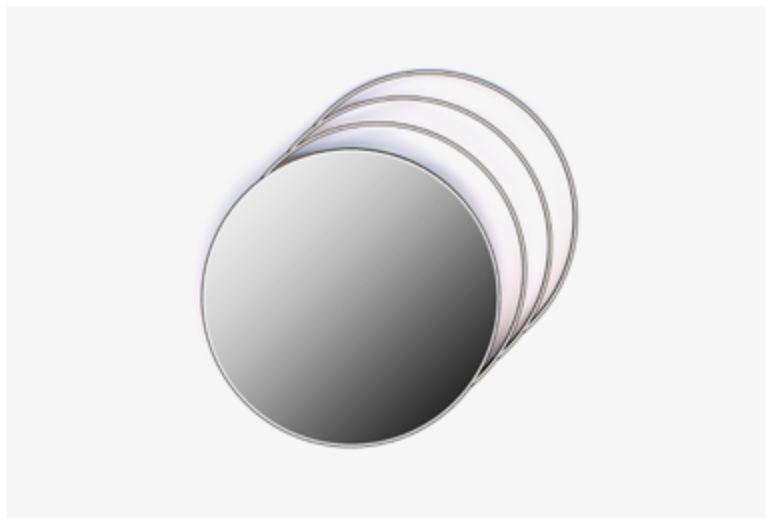

INFINITY MIRROR

MATERIALS

Structure: metal
Central body: mirror

FINISHES

Structure: black nickel

Light source: LED
Total power: 69W / Voltage: 220-240 V / Rated Luminous Flux: 2277 Lm / Colour temperature: 3000°K / Color Rendering Index: Standard CRI 90 / Dimmer function: Yes

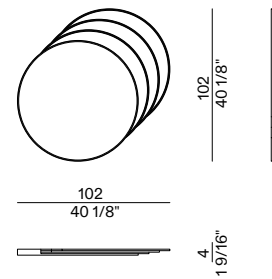

FANUS SUSPENSION

MATERIALS

Structure: metal
Lampshade: glass, fabric
Lighting body: glass

FINISHES

Structure: matt black painted finish
Lampshade: Murano glass col. Amber
Lighting body: transparent blown ribbed Murano glass

Light source: Illuminatore CC LED
Total power: 16,6W / Input Voltage (driver): 220-240V / Luminous Flux: 1800 lm / Colour temperature: 3000°K / Color Rendering Index: 80 / Dimmer function: NO

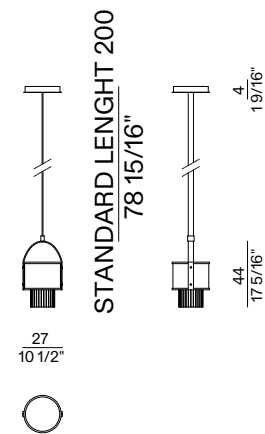

FANUS FLOOR

MATERIALS

Structure: metal
Lampshade: glass, fabric
Lighting body: glass

FINISHES

Structure: matt black painted finish
Lampshade: Murano glass col. Amber
Lighting body: transparent blown ribbed Murano glass

Light source: Illuminatore CC LED
Total power: 16,6W / Input Voltage (driver): 220-240V / Luminous Flux: 1800 lm / Colour temperature: 3000°K / Color Rendering Index: 80 / Dimmer function: NO

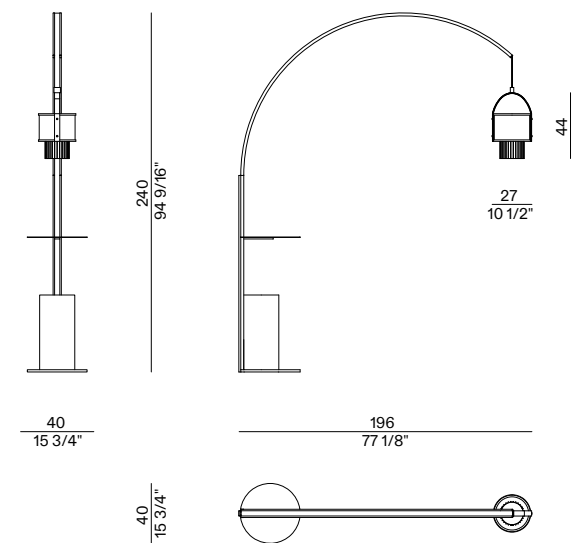

FANUS TABLE

MATERIALS

Structure: metal
Lampshade: glass, fabric
Lighting body: glass

FINISHES

Structure: matt black painted finish
Lampshade: Murano glass col. Amber
Lighting body: transparent blown ribbed Murano glass

Light source: Illuminatore CC LED
Total power: 2,1W / Voltage: Batteria 3,7V - 2600mAh / Luminous Flux: 300 lm / Colour temperature: 3000°K / Color Rendering Index: 84 / Dimmer function: Dimmerabile touch

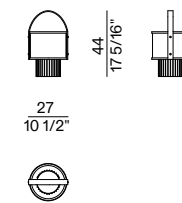



MANTA FLOOR

MATERIALS

Lighting body: glass
Structure: brass

FINISHES

Glass: col. Amber fumé
Brass: natural

Light source: LED
Total power: 10W / Voltage: 220-240 V / Rated Luminus Flux:
800 Lm / Colour temperature: 3000°K / Color Rendering
Index: Standard CRI>80 / Dimmer function: No

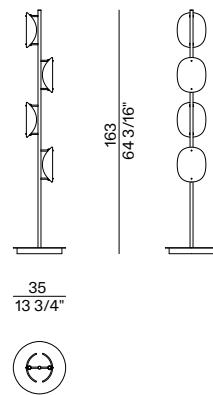

MANTA TABLE

MATERIALS

Lighting body: glass
Structure: brass

FINISHES

Glass: col. Amber fumé
Brass: natural

Light source: LED
Total power: 10W / Voltage: 220-240 V / Rated Luminus Flux:
800 Lm / Colour temperature: 3000°K / Color Rendering
Index: Standard CRI>80 / Dimmer function: No

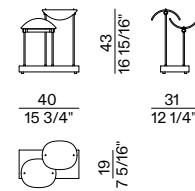

MANTA SUSPENSION

MATERIALS

Lighting body: glass
Structure: brass

FINISHES

Glass: col. Amber fumé
Brass: natural

Light source: LED
Total power: 10W / Voltage: 220-240 V / Rated Luminus Flux:
800 Lm / Colour temperature: 3000°K / Color Rendering
Index: Standard CRI>80 / Dimmer function: No

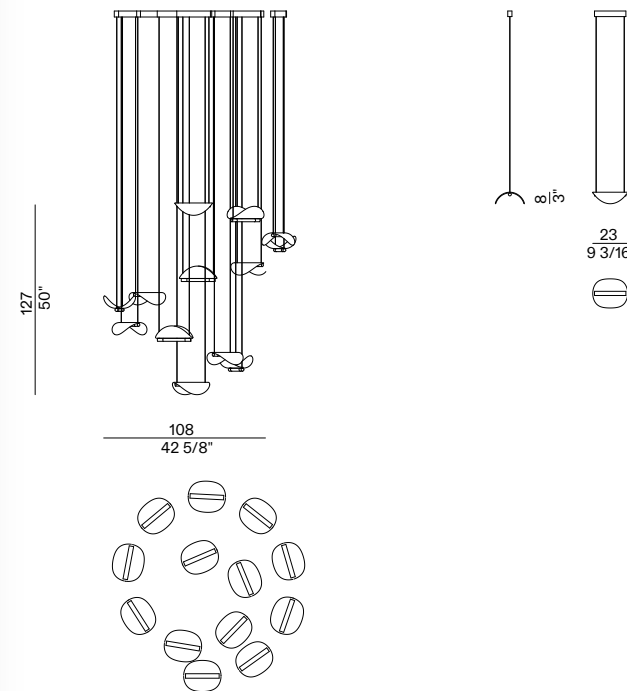

ORIGAMI WALL

MATERIALS

Structure: metal, brass

FINISHES

Structure: matt gold finish, matt and polished black

Light source: LED
Total power: 6W / Voltage: 24 V / Rated Luminus Flux: 600
Lm / Colour temperature: 3000°K / Color Rendering Index:
Standard CRI 90 / Dimmer function: No

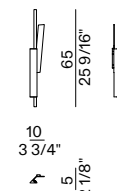



ABSTRACT LOW CABINET

MATERIALS

Structure: blockboard wood
 Covering: brass
 Base: metal

FINISHES

Structure: walnut stained ash
 Covering: antique brass
 Dimmer function: Yes

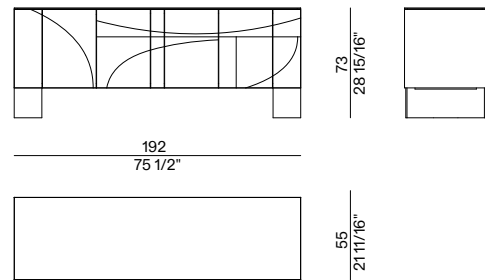

ABSTRACT HIGH CABINET

MATERIALS

Structure: blockboard wood
 Covering: brass
 Base: metal

FINISHES

Structure: walnut stained ash
 Covering: antique brass
 Dimmer function: Yes

Shelves

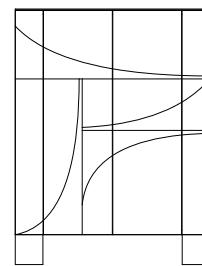

Drawers

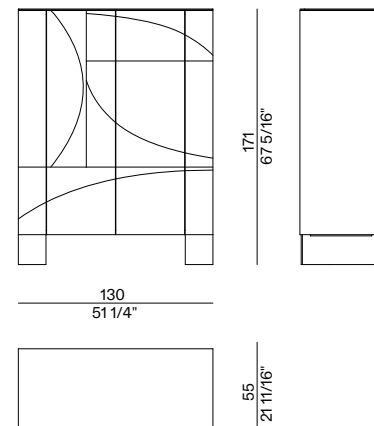

THE RUGS

IT Una rielaborazione geometrica delle forme da vita a motivi decorativi astratti e architettonici, rendendo il tappeto un interessante accessorio al passo con i tempi ma con radici nella memoria. Suggestioni provenienti dalle correnti artistiche del 900 animano i tappeti novità 2023, parte della collezione "Alla Sera". Ogni singolo tappeto è stato prodotto con la tecnica handtuft in India. Il blend di lana e viscosa utilizzato è una qualità di filato innovativa e altamente performante che permette ai tappeti di abitare ambienti privati ma anche spazi contract. Mark, Vasilij, Paul, Piet, Theo, Frank, Jackson, Bridget: ogni tappeto si distingue per un equilibrio di contrasti in linea con l'approfondita ricerca cromatica e materica condotta dall'azienda.

EN A geometric reworking of the shapes gives life to abstract and architectural decorative motifs, making the rug an interesting accessory in step with the times but rooted in memory. Suggestions from the artistic currents of the 20th century enliven the new 2023 rugs, part of the 'Alla Sera' collection. Every single rug has been produced in India using the hand tufted technique. The blend of wool and viscose used is an innovative, high-performance yarn quality that allows the rugs to inhabit both private and contract spaces. Mark, Vasilij, Paul, Piet, Theo, Frank, Jackson, Bridget: each rug is distinguished by a balance of contrasts in line with the in-depth colour and material research conducted by the company.

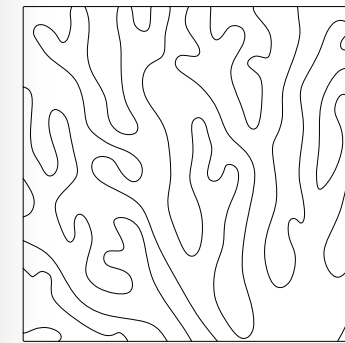

Jackson carpet
 400 x 400
 157 1/2" x 157 1/2"

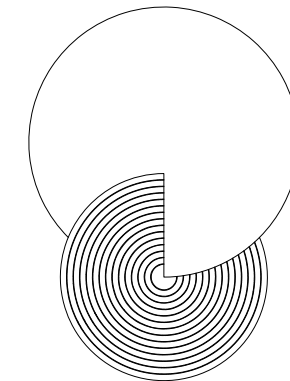

Mark Carpet
 300 x 415
 118 1/8" x 163 3/8"

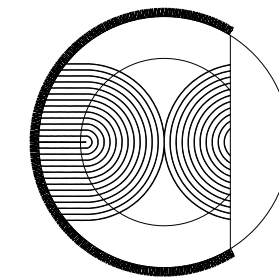

Paul Carpet
 300 x 300
 118 1/8" x 118 1/8"

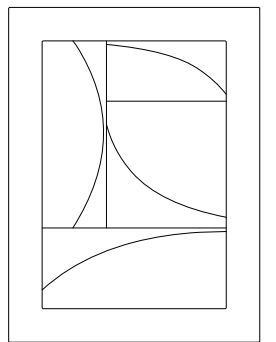

Vasilij Carpet
 300 x 400
 118 1/8" x 157 1/2"

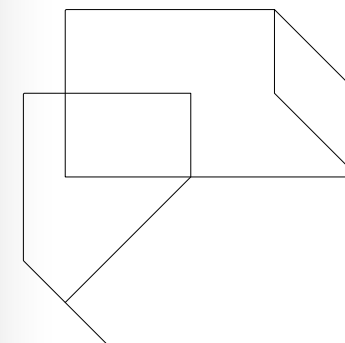

Piet Carpet
 400 x 400
 157 1/2" x 157 1/2"

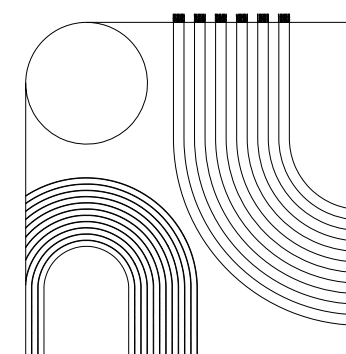

Theo Carpet
 400 x 400
 157 1/2" x 157 1/2"

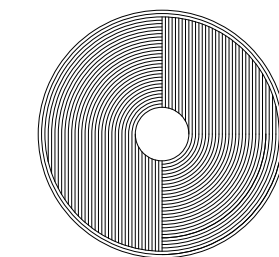

Frank Carpet
 296 x 296
 116 9/16" x 116 9/16"



Paolo Castelli
Alla Sera

Graphic design
LaTigre

Photo
Miro Zagnoli

Print
Moderna Industrie Grafiche
April 2023

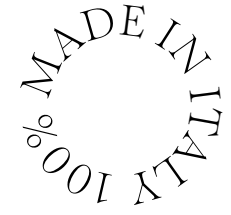

Headquarter:
Via I° Maggio, 93
40064, Ozzano dell'Emilia
Bologna - Italy

Contacts:
Tel. +39 051 4695511
Info@paolocastellipa.com
www.paolocastelli.com

Offices and Showrooms:
Milan, Contract Office & Showroom
Paris, Contract Office & Showroom
Carrara, Marine Division