

L I G H T I N G



PAOLO CASTELLI

C A T A L O G U E



PAOLO CASTELLI



Paolo Castelli S.p.A è azienda italiana leader nel settore del design e del global contracting a livello nazionale e internazionale. Nata da un'intuizione di Paolo Castelli, l'azienda ha saputo coniugare tradizione e innovazione dando vita a collezioni indoor e outdoor "total look" sempre attuali in grado di raccontare la contemporaneità, anticipando le tendenze e rispondendo alle esigenze del mercato. Paolo Castelli S.p.A è in grado di soddisfare le esigenze dei progettisti e le richieste del cliente finale offrendo soluzioni custom made sviluppate intorno ai concetti di eccellenza e alta qualità: una visione dinamica che ha condotto l'azienda italiana a diventare il partner ideale per ambiziosi progetti contract in tutto il mondo.

L'azienda Paolo Castelli nasce dalla storica tradizione della famiglia bolognese Castelli, la cui attività imprenditoriale nel campo dell'arredo inizia alla fine dell'800. Da un'ebanisteria artigianale aperta nel 1887 nel cuore di Bologna, all'azienda Domodinamica, specializzata in arredi per l'ufficio e di design: la famiglia Castelli ha messo a servizio di rinomati designer la sapiente maestria artigiana maturata negli anni. Per Domodinamica hanno infatti disegnato Michele De Lucchi, Karim Rashid, Pier Luigi Cerri, Alessandro Mendini, Stefano Giovannoni, Luca Scacchetti, Denis Santachiara, Angelo Micheli, Massimo Iosa Ghini. Dall'evoluzione dell'azienda, nasce il marchio Paolo Castelli che si occupa di product design e grandi progetti da general contractor. Queste due anime dell'azienda sono strettamente interconnesse, e rendono oggi Paolo Castelli sinonimo di eccellenza Made in Italy, innovazione, ricerca ed eleganza.

Dall'arredo all'illuminazione, Paolo Castelli ha saputo dare vita ad un ampio catalogo con diverse quanto uniche proposte di arredo indoor e outdoor in grado di esprimere una filosofia dell'abitare all'insegna di un'eleganza sofisticata, che viene svelata in ciascuna delle collezioni. Un unico racconto, plurimi linguaggi espressivi. Maestria artigiana e creatività si esaltano di collezione in collezione raccontando l'anima poliedrica del brand: suggestioni artistiche si fondono con reinterpretazioni in chiave moderna dei grandi stili che hanno caratterizzato le epoche del design. Sperimentazione, ricerca e sviluppo danno vita a collezioni sempre più sostenibili, che comunicano l'impegno di Paolo Castelli nell'offrire arredi e complementi di design in cui estetica e funzionalità si uniscono in un'ottica sostenibile. Ogni collezione dialoga con l'altra grazie all'altissima varietà e qualità delle finiture: materiali e cromie si esaltano in combinazioni sempre nuove, rendendo ogni arredo unico e altamente personalizzabile. Grazie ai continui investimenti in termini di ricerca e sviluppo, Paolo Castelli si distingue per una manodopera altamente specializzata al servizio delle anime di cui si compone.

Un racconto di innovazione e tradizione A tale of innovation and tradition

Paolo Castelli S.p.A is a leading Italian company in the design and global contracting sector at a national and international level. Born from an intuition of Paolo Castelli, the company has been able to combine tradition and innovation by creating ever-present "total look" indoor and outdoor collections able to describe the contemporaneity, anticipating trends and responding to market requests. Paolo Castelli S.p.A is able to satisfy the needs of designers and the wishes of the end customer by offering custom made solutions developed around the concepts of excellence and high quality: a dynamic vision that has led the Italian company to become the ideal partner for ambitious projects contract all over the world.

The Paolo Castelli company was born from the historic tradition of the Castelli family from Bologna, whose entrepreneurial activity in the field of furniture began at the end of the 19th century. From an artisan cabinet-making shop opened in 1887 in the heart of Bologna, to the Domodinamica company, specialized in office and design furniture: the Castelli family has put the skilful craftsmanship gained over the years at the service of renowned designers. In fact, Michele De Lucchi, Karim Rashid, Pier Luigi Cerri, Alessandro Mendini, Stefano Giovannoni, Luca Scacchetti, Denis Santachiara, Angelo Micheli, Massimo Iosa Ghini designed for Domodinamica. From the evolution of the company, Paolo Castelli brand was born, which deals with product design and large projects as a general contractor. These two souls of the company are closely interconnected, and today make Paolo Castelli synonymous with Made in Italy excellence, innovation, research and elegance.

From furnitures to lighting, Paolo Castelli has been able to create an extensive catalog with diverse and unique indoor and outdoor furniture proposals capable of expressing a philosophy of living the home space in the name of sophisticated elegance, which is revealed in each of the collections. A single story, multiple expressive languages. Craftsmanship and creativity are enhanced from collection to collection, narrating the multifaceted soul of the brand: artistic suggestions merge with modern reinterpretations of the great styles that have characterized the design eras. Experimentation, research and development give life to increasingly sustainable collections, which communicate Paolo Castelli's commitment to offering design furniture and accessories in which aesthetics and functionality come together in a sustainable perspective. Each collection dialogues with the other thanks to the very high variety and quality of the finishes: materials and colors are enhanced in ever new combinations, making each piece of furniture unique and highly customizable. Thanks to continuous investments in terms of research and development, Paolo Castelli stands out for a highly specialized workforce at the service of the souls of which the company is composed.

Index

Lampade a sospensione
Suspension Lamps

013

~

Lampade a muro & Applique
Wall & Ceiling Lamps

043

~

Lampade da terra
Floor Lamps

69

~

Lampade da tavolo
Table Lamps

85

Abacus

Lampade a sospensione
Suspension Lamps



MY LAMP SUSPENSION 14



MY LAMP ROUND SUSPENSION 16



LABILIS COMPOSITION SUSPENSION 18



LABILIS RINGS SUSPENSION 20



MANTA SUSPENSION 22



FANUS SUSPENSION 24



STELLANTIS SUSPENSION 26



KALÌ SUSPENSION 28



GOLDEN CLOUD SUSPENSION 30



GOLDEN DISC SUSPENSION 32



ALLURE SUSPENSION 34



ALLURE SIDE SUSPENSION 36



JOY SUSPENSION 38



TERMINAL SUSPENSION 40

Lampade da muro & Applique
Wall & Ceiling Lamps



MY LAMP WALL 44



KALÌ WALL 46



ANODINE WALL 48



ANODINE CIRCLE WALL 50

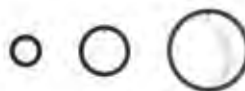

LABILIS WALL 52



ORIGAMI WALL 54



FAIR WALL

56



GOLDEN DISC WALL

58



GOLDEN CLOUD WALL

59



CIRCLE WALL

60



JOY WALL

62



GALAXY WALL

64



MY LAMP CEILING

66

Lampade da terra
Floor Lamps



SORELUNA FLOOR

70



MANTA FLOOR

72



MY LAMP FLOOR

74



FANUS FLOOR

76



ANODINE FLOOR

78



COMET FLOOR

80



ICONE LUMINOSE FLOOR

82

Lampade da tavolo
Table Lamps



FANUS TABLE

86



MANTA TABLE

88



MY LAMP TABLE

90



COMET TABLE

92



ANODINE TABLE

94



HUGO & COLETTE TABLE

96



AMBRA TABLE

98



NETTUNO TABLE

100



OSCAR TABLE

102



KAALA TABLE

104



ICONE LUMINOSE TABLE

106

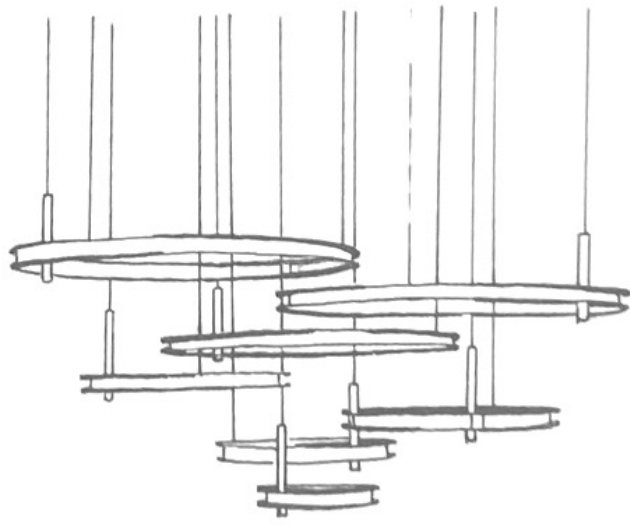



Lampade a sospensione
Suspension Lamps

My Lamp Suspension

DESIGN | PAOLO CASTELLI

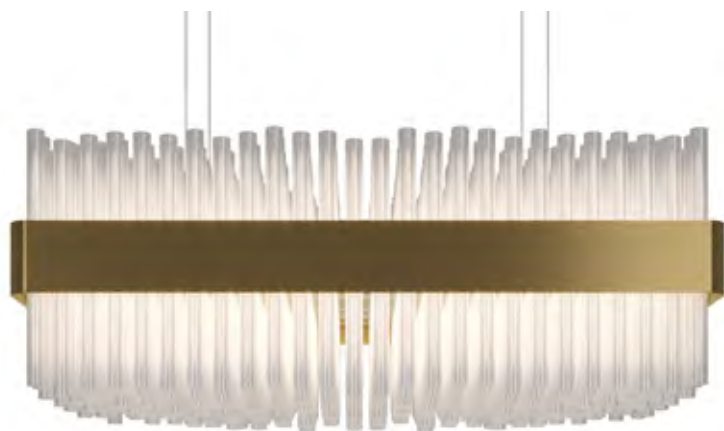

Finishes of the above picture



Alternative finishes



My Lamp crea un effetto dinamico e di forte impatto se disposto in più pezzi. Ideale per salotti e sale da pranzo raffinati dove si vuole creare un ambiente sofisticato ma non convenzionale. È composto da un importante “bouquet” di tubi realizzati in vetro borosilicato veneziano posti ad altezze sfasate e raccolti in una fascia metallica curvata, trattata con particolare finitura a più strati oro opaco o nichel nero opaco. Il telaio portante interno è realizzato in metallo nichelato. Contropiastra opalescente per diffondere la luce. Disponibile in versione rettangolare e quadrata.

My Lamp creates a dynamic and strong impact when several pieces are placed in a room. Ideal in elegant lounges and dining rooms that want to create a sophisticated but unconventional ambience. It comprises a considerable “bouquet” of venetian borosilicate glass tubes, fixed at different heights and bound together by a curved metal band with a unique matt gold finish or matt black nickel finish. The internal supporting frame is made of nickel-plated metal. Opalescent counterplate to diffuse the light. Available in both a rectangular and a square versions.

RECTANGULAR

TECHNICAL SHEET
MY LAMP RECTANGULAR
Light source: STRIP LED 12W/M
Total power: 132W
Voltage: 12V
Rated luminous flux: 7200 lm
Colour temperature: 2700°K
Colour rendering index: Ra80
Suspension cable lenght: 200 cm
Dimmer function: Yes
Weight: Kg 132
Standard cable length: 2m

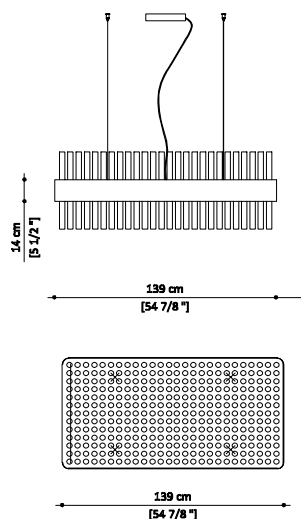

SQUARE

TECHNICAL SHEET
MY LAMP SQUARE
Light source: STRIP LED 8W/M
Total power: 115W
Voltage: 110-230V
Rated luminous flux: 9360 lm
Colour temperature: 2700°K
Colour rendering index: Ra80
Suspension cable lenght: 200 cm
Dimmer function: Yes
Weight: Kg 100
Standard cable length: 2m

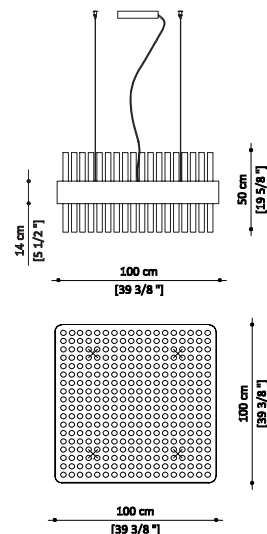

SUSPENSION RECTANGULAR | ILL.MYLA.220

Metal band in matt gold finish. Transparent borosilicate glass tubes

SUSPENSION RECTANGULAR BLACK NICKEL | ILL.MYLA.220.BN

Metal band in matt black nickel finish. Transparent borosilicate glass tubes

SUSPENSION SQUARE | ILL.MYLA.210

Metal band in matt gold finish. Transparent borosilicate glass tubes

SUSPENSION SQUARE BLACK NICKEL | ILL.MYLA.210.BN

Metal band in matt black nickel finish. Transparent borosilicate glass tubes



My Lamp Round Suspension

DESIGN | PAOLO CASTELLI



Finishes of the above picture



Metal Finish
Matt Gold

Alternative finishes



Metal Finish
Matt Black
Nickel

“My Lamp Round” sono eleganti lampadari circolari disponibili in diametri di 50 e 100 cm. Possono essere disposti in modo creativo per creare un effetto dinamico e suggestivo, particolarmente adatto a ambienti come salotti e sale da pranzo. Questi lampadari aggiungono un tocco di sofisticatezza e originalità agli spazi raffinati, offrendo un’atmosfera unica e non convenzionale. È composto da un importante “bouquet” di tubi realizzati in vetro borosilicato veneziano posti ad altezze sfasate e raccolti in una fascia metallica curvata, trattata con particolare finitura a più strati oro opaco. Il telaio portante interno è realizzato in metallo nichelato. Contropiastra opalescente per diffondere la luce.

“My Lamp Round” are elegant circular chandeliers available in diameters of 50 and 100 cm. They can be arranged in a creative way to create a dynamic and suggestive effect, particularly suitable for environments such as living rooms and dining rooms. These chandeliers add a touch of sophistication and originality to refined spaces, offering a unique and unconventional atmosphere. It is composed of a considerable “bouquet” of tubes made of Venetian borosilicate glass placed at different heights and collected in a curved metal band, which is treated with a particular matt gold finish or matt black nickel finish. The internal supporting frame is made of nickel-plated metal. Opalescent counterplate to diffuse the light.

Ø50

TECHNICAL SHEET

MY LAMP ROUND 50

Light source: STRIP LED 8W/M

Total power: 55W

Voltage: 110-240V

Rated luminous flux: 4420 lm

Colour temperature: 2700°K

Colour rendering index: Ra80

Suspension cable length: 150 cm

Dimmer function: Yes

Weight: Kg 40

Standard cable length: 2m

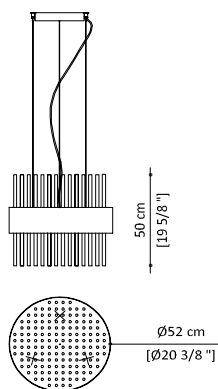

Ø100

TECHNICAL SHEET

MY LAMP ROUND 100

Light source: STRIP LED 8W/M

Total power: 128W

Voltage: 115-230V

Rated luminous flux: 9750 lm

Colour temperature: 2700°K

Colour rendering index: Ra80

Dimmer function: Yes

Weight: Kg 130

Standard cable length: 2m

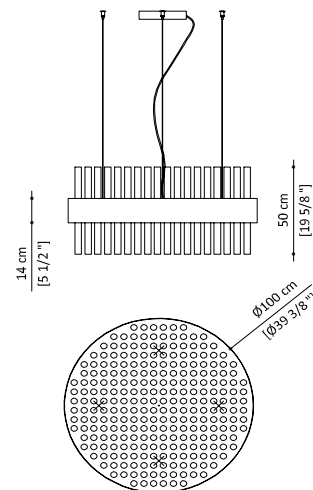

SUSPENSION ROUND 50 | ILL.MYLA.201

Metal band in matt gold finish. Transparent borosilicate glass tubes

SUSPENSION ROUND 50 BLACK NICKEL | ILL.MYLA.201.BN

Metal band in matt black nickel finish. Transparent borosilicate glass tubes

SUSPENSION ROUND 100 | ILL.MYLA.200

Metal band in matt gold finish. Transparent borosilicate glass tubes

SUSPENSION ROUND 100 BLACK NICKEL | ILL.MYLA.200.BN

Metal band in matt black nickel finish. Transparent borosilicate glass tubes



◀ Bouquet di tubi realizzati in vetro borosilicato veneziano.

Bouquet of glass tubes made of Venetian borosilicate glass.



Labilis Composition Suspension

DESIGN | PAOLO CASTELLI



Finishes of the above picture

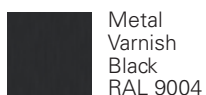

Metal Varnish
Black
RAL 9004



Metal Finish
Matt
Bronzed
Brass



Rosone cilindrico in metallo con alimentatore interno, adatto per installazione a soffitto (optional). Metal cylindrical rose holding local drivers, suitable for ceiling installation (optional). Dim. Ø9 x h 20cm

Un nuovo alfabeto grafico fatto di essenziali elementi geometrici che disegnano nello spazio contemporanee forme di luce. Tre anelli di diverso diametro installabili singolarmente o in composizione da 4, 7 e 10 anelli. L'anello in metallo è in finitura nero opaco con diffusore di luce LED in policarbonato opalino bianco perimetrale. Ogni anello monta uno spot in ottone finitura bronzo ottone opaco. Gli anelli presentano tre cavi di sospensione, di cui uno di alimentazione. Optional su richiesta: anelli dimmerabili e rosoni cilindrici in metallo con alimentatore interno, adatto per installazione a soffitto.

A new graphic alphabet consisting of essential geometric elements that create contemporary light forms in the space. Three rings in different diameters can be installed separately or as composition (4, 7, 10 rings). The metal ring is in satin black finish, with light diffuser in white opal polycarbonate along the perimeter. Each ring carries a LED spot in matt brass bronze finish. Each ring has three suspension cables, one of which is a power supply one. Optionals available on request: dimmable rings; metal cylindrical roses holding local drivers, suitable for ceiling installation.

4 RINGS

TECHNICAL SHEET

4 RINGS

Light source: Strip LED 140 LED/m + spot LED (4X)
Total power: 35W - Strip LED 14,4W/m; spot 4,2W (10X)
Voltage: 230V
Rated luminous flux spots: 1320 lm
Rated luminous flux strip LED: 6357 lm
Colour temperature: 2700°K
Colour rendering index: 90
Dimmer function: Yes - only for rings
Cables length: 2mt
Weight: 18 Kg
Standard cable length: 2m

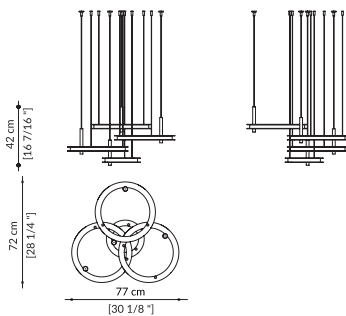

4 RINGS | ILL.LABI.230

1 ring Ø27 + 3 rings Ø43 in metal matt black varnished and LED spots in matt bronzed brass. Remote drivers

OPTIONAL * | OPT.ILL.LABI.CEIL

4 metal cylindrical roses holding local drivers, suitable for ceiling installation

7 RINGS

TECHNICAL SHEET

7 RINGS

Light source: Strip LED 140 LED/m + spot LED (7X)
Total power: 77W - Strip LED 14,4W/m; spot 4,2W (7X)
Voltage: 230V
Rated luminous flux spots: 2310 lm
Rated luminous flux strip LED: 14928 lm
Colour temperature: 2700°K
Colour rendering index: 90
Dimmer function: Yes - only for rings
Cables length: 2mt
Weight: 40 Kg
Standard cable length: 2m

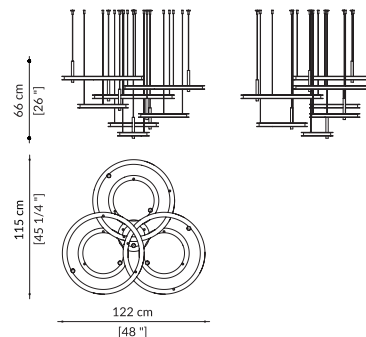

7 RINGS | ILL.LABI.220

1 ring Ø27 + 3 rings Ø43 + 3 rings Ø70 in metal matt black varnished and LED spots in matt bronzed brass. Remote drivers

OPTIONAL * | OPT.ILL.LABI.CEIL

N°7 metal cylindrical roses holding local drivers, suitable for ceiling installation



10 RINGS

TECHNICAL SHEET

10 RINGS

Light source: Strip LED 140 LED/m + spot LED (10X)
 Total power: 97W - Strip LED 14,4W/m; spot 4,2W (10X)
 Voltage: 230V
 Rated luminous flux spots: 3300 lm
 Rated luminous flux strip LED: 17541 lm
 Colour temperature: 2700°K
 Colour rendering index: 90
 Dimmer function: Yes - only for rings
 Cables length: 2mt
 Weight: 48 Kg
 Standard cable length: 2m

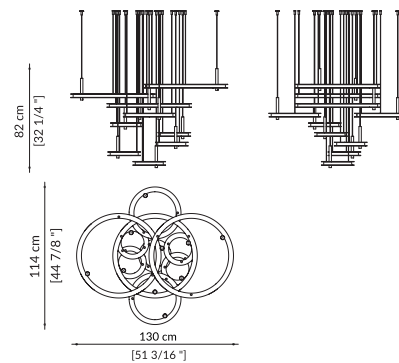

10 RINGS | ILL.LABI.210

N° 10 tubes spot LED I finish matt bronzed brass
 5 rings Ø27 + 2 rings Ø43 + 3 rings Ø70 in metal matt black varnished and LED spots in matt bronzed brass. Remote drivers

OPTIONAL* | OPT.ILL.LABI.CEIL

N°10 metal cylindrical roses holding local drivers, suitable for ceiling installation

Labilis Rings Suspension

DESIGN | PAOLO CASTELLI



Finishes of the above picture



Metal
Varnish
Black
RAL 9004



Metal Finish
Matt
Bronzed
Brass



Rosone cilindrico in metallo con alimentatore interno, adatto per installazione a soffitto (optional). Metal cylindrical rose holding local drivers, suitable for ceiling installation (optional).
Dim. Ø9 x h 20cm

Tre anelli di diverso diametro installabili singolarmente o in composizione da 4, 7 e 10 anelli. L'anello in metallo è finitura nero opaco con diffusore di luce LED in policarbonato opalino bianco perimetrale. Ogni anello monta uno spot in ottone finitura bronzo ottone opaco. Gli anelli presentano tre cavi di sospensione, di cui uno di alimentazione. Optionals su richiesta: anelli dimmerabili; rosone cilindrico in metallo con alimentatore interno, adatto per installazione a soffitto.

Three rings of different diameters can be installed separately or as composition (4, 7, 10 rings). The metal ring is in satin black finish, with light diffuser in white opal polycarbonate along the perimeter. Each ring carries a LED spot in matt brass bronze finish and has three suspension cables, one of which is a power supply one. Optionals available on request: dimmable rings; metal cylindrical rose holding local driver, suitable for ceiling installation.

Ø27

TECHNICAL SHEET

LABILIS Ø27

Light source: Strip LED 140 LED/m + spot LED
Total power: 7,3W - Strip LED 14,4W/m; spot 4,2W
Voltage: 230V
Rated luminous flux spot: 330 lm
Rated luminous flux strip LED: 1092 lm
Colour temperature: 2700°K
Colour rendering index: 90
Dimmer function: Yes - only for ring
Weight: 3 Kg
Standard cable length: 2m

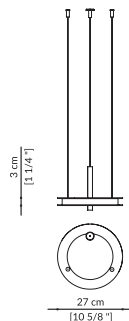

RING Ø27 | ILL.LABI.231

1 ring Ø27 in metal matt black varnished and LED spot in matt bronzed brass. Remote drivers
OPTIONAL * | OPT.ILL.LABI.CEIL
Metal cylindrical rose holding local driver, suitable for ceiling installation

Ø43

TECHNICAL SHEET

LABILIS Ø43

Light source: Strip LED 140 LED/m + spot LED
Total power: 9,7W - Strip LED 14,4W/m; spot 4,2W
Voltage: 230V
Rated luminous flux spots: 330 lm
Rated luminous flux strip LED: 1755 lm
Colour temperature: 2700°K
Colour rendering index: 90
Dimmer function: Yes - only for ring
Weight: 4,5 Kg
Standard cable length: 2m

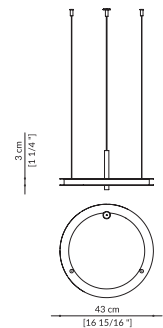

RING Ø43 | ILL.LABI.221

1 ring Ø43 in metal matt black varnished and LED spot in matt bronzed brass. Remote drivers
OPTIONAL * | OPT.ILL.LABI.CEIL
Metal cylindrical rose holding local driver, suitable for ceiling installation



Ø70

TECHNICAL SHEET

LABILIS Ø70

Light source: Strip LED 140 LED/m + spot LED

Total power: 13,6W - Strip LED 14,4W/m; spot 4,2W

Voltage: 230V

Rated luminous flux spots: 330 lm

Rated luminous flux strip LED: 2857 lm

Colour temperature: 2700°K

Colour rendering index: 90

Dimmer function: Yes - only for ring

Weight: 7,3 Kg

Standard cable length: 2m

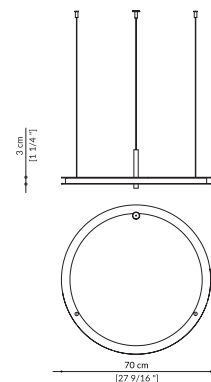

RING Ø70 | ILL.LABI.211

1 ring Ø70 in metal matt black varnished and LED spot in matt bronzed brass. Remote drivers

OPTIONAL* | OPT.ILL.LABI.CEIL

Metal cylindrical rose holding local driver, suitable for ceiling installation

Manta

Suspension

DESIGN | VITTORIO PARADISO



Finishes of the above picture



Murano Glass
Col. Amber
Hand-forged



Natural
Brass



Rosetta rettangolare in metallo finitura oro opaco con alimentatore interno, adatto per installazione a soffitto (optional)*. Rectangular metal rosette matt gold finish holding local drivers, suitable for ceiling installation (optional) *. Dim. 22x5x4 cm

Manta è una scenografica lampada a sospensione che per la sua eterea leggerezza ricorda gli iconici Mobile di Alexander Calder. Il corpo illuminante con sorgente a LED incapsulata in una struttura cilindrica in ottone satinato è una foglia in vetro color ambra, forgiata a mano dai maestri vetrai di Murano. Ha una forma delicata e sinuosa e il lampadario sembra volare, grazie alle piccole foglie che volteggiano nell'aria, legate a sottilissimi cavi di sospensione. Su richiesta ogni pendente viene fornito di una rosetta contenente il driver per il posizionamento a soffitto.

Manta is a scenographic suspension lamp whose ethereal lightness recalls the iconic Mobile sculpture by Alexander Calder. Amber coloured glass leave, hand-forged in Murano, encapsulated in a cylindrical satin brass structure which contains the LED light source. It has a delicate and sinuous shape and seems to be flying in the air, hanging from very thin electrified suspension cables. On request any pendant can be provided with metal rosette holding local driver suitable for ceiling installation.

TECHNICAL SHEET

MANTA SUSPENSION
Light source: LED
Total power: 5W
Voltage: 220-240V
Rated Luminous Flux: 400 lm
Colour temperature: 3000°K
Color Rendering Index: Standard CRI>80
Suspension cable length: 200 cm
Dimmer function: No
Weight: Kg 3
Standard cable length: 2m

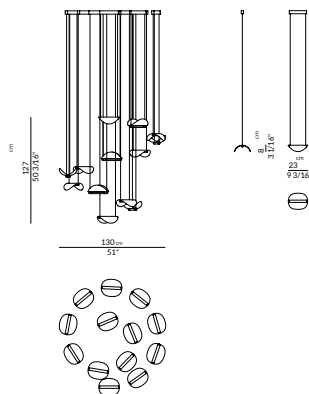

*OPTIONAL CEILING ROSETTE

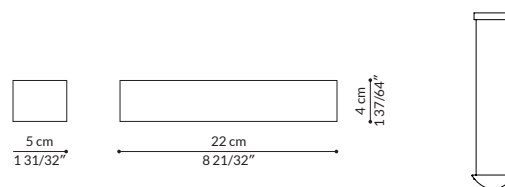

MANTA AMBER | ILL.MANT.200

Amber coloured glass leave, hand-forged in Murano, encapsulated in a cylindrical satin brass structure which contains the LED light source. Remote drivers

MANTA FUMÈ | ILL.MANT.201

Fumè coloured glass leave, hand-forged in Murano, encapsulated in a cylindrical satin brass structure which contains the LED light source. Remote drivers

MANTA ROSETTE | OPT.ILL.MANT.CEIL

Metal ceiling support in metal finish matt gold, which contains the driver, in case driver needs to be installed on the ceiling



Fanus Suspension

DESIGN | PAOLO CASTELLI



Finishes of the above picture



Metal
Varnish
Black
RAL 9004



Natural
Brass



Leather
Cuoio
Col. 26
Natural



Murano Glass
Transparent
Blown ribbed



Murano Glass
Col. Amber
Hand-forged



Fabric
Natural
Col. Ivory

Una lampada a sospensione pensata per illuminare lo spazio e regalare l'intimità dell'ombra. La famiglia Fanus reinterpreta il concetto di lanterna, distinguendosi per i dettagli in cuoio naturale che impreziosiscono l'intera figura. Fanus è disponibile anche in versione da terra e da tavolo. Lampada a sospensione con dettagli in cuoio naturale. Rosone in metallo di forma rotonda nero. Il corpo lampada un tubolare rivestito in cuoio dentro il quale passano i cavi di sospensione e alimentazione. Il corpo illuminante è in vetro cannettato trasparente con sorgente luminosa LED. Il paralume è disponibile in due versioni: in tessuto o in vetro di Murano curvato color ambra con parti metalliche verniciate di nero. Accensione tramite interruttore.

A pendant lamp designed to illuminate the space and provide the intimacy of shadows. The Fanus family reinterprets the concept of a lantern, distinguished by natural leather details that embellish the entire design. Fanus is also available in floor and table lamp versions. Pendant lamp with natural leather details. Round-shaped black metal canopy. The lamp body is a tubular structure covered in leather, through which the suspension and power cables pass. The lighting element is made of transparent ribbed glass with an LED light source. The lampshade is available in two versions: fabric or curved Murano glass in amber color with black painted metal parts. Switch-controlled activation.

TECHNICAL SHEET
FANUS SUSPENSION
Light source: CC LED
Total power: 16,6W
Input Voltage (driver): 220-240V
Rated luminous flux: 1800 lm
Colour temperature: 3000°K
Colour rendering index: 80
Dimmer function: No
Weight with glass: 11 Kg
Weight with lampshade: 9 Kg
Standard cable length: 2m

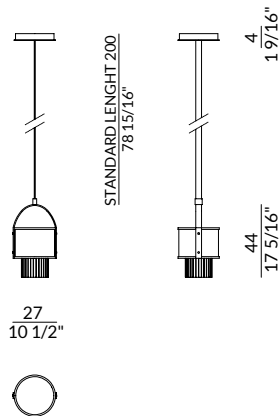

FANUS SUSPENSION LAMP GLASS | ILL.FANU.220
Structure in black metal with brass details, blown ribbed glass, lampshade in glass Col. Amber
FANUS SUSPENSION LAMP FABRIC | ILL.FANU.221
Structure in black metal with brass details, blown ribbed glass, lampshade in fabric Col. Ivory



Inspiration

Stellantis Suspension

DESIGN | PAOLO CASTELLI



Finishes of the above picture



Murano Glass
Col. Amber
Hand-forged



Metal Finish
Polished
Gold

Stellantis è una scultura luminosa sospesa, immaginata per diventare il centro focale dell'ambiente. Suggestiva e poetica, è composta da sei coni in vetro con sfumatura metallizzata bronzo - realizzati su misura dai maestri vetrai di Murano - fissati su un'asta verticale in ottone. Illuminati da sorgente a LED, gli elementi in vetro diffondono nell'ambiente riflessi cangianti con un effetto espressivo e scenografico. Anche dimmerabile.

Stellantis is a suspended light sculpture, designed to become the focal point of the environment. Suggestive and poetic, it is a composition of six glass cones with a metallic bronze shade - custom made by Murano glass masters - fixed on a vertical brass rod. Illuminated by a LED source, the glass elements diffuse iridescent reflections into the environment with an expressive and scenographic effect. Also dimmable.

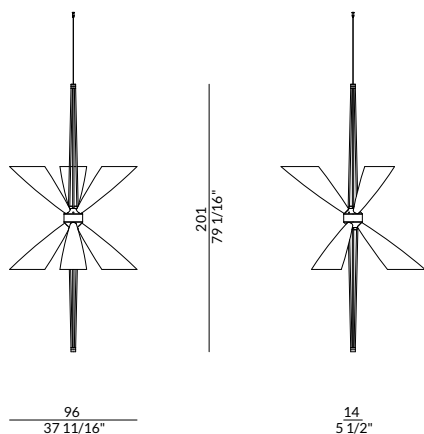

TECHNICAL SHEET

STELLANTIS

Light source: LED

Total power: 32W

Voltage: 220V

Rated Luminous Flux: 2180 lm

Colour Temperature: 3000°K

Color Rendering Index: Standard CRI>90

Suspension cable length: 200 cm

Dimmer function: Yes

Weight: 18 kg

Standard cable length: 2m

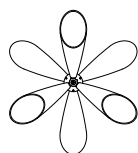

STELLANTIS | ILL.STEL.200

Composition of six glass cones with a metallic bronze shade, handmade in Murano glass, fixed on a vertical brass rod. Illuminated by a LED source

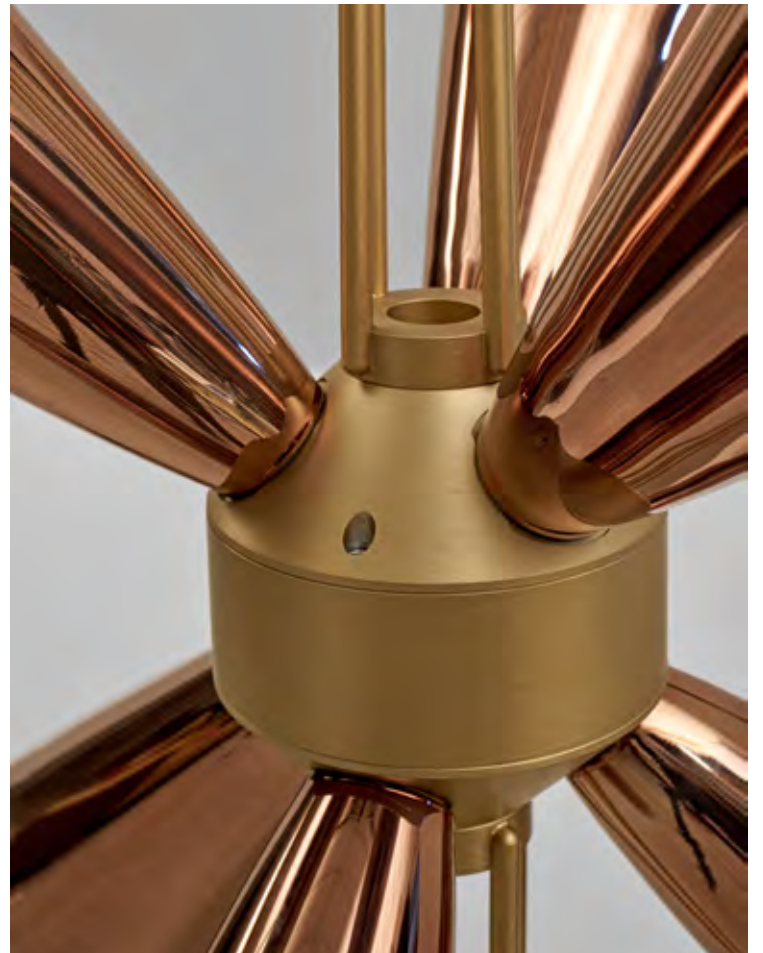

◀ Vetri realizzati su misura dai maestri vetrai di Murano.

Glass cones custom made by Murano glass masters.



Kali

Suspension

DESIGN | PAOLO CASTELLI



Finishes of the above picture



Metal Finish
Matt Gold



Murano glass with
24KT golden leaf
powder

Chandelier di imponenza scultorea che crea oniriche geometrie di luci tra bracci che sorreggono candele dorate. Kali chandelier vanta una lavorazione creata interamente sulla isola di Murano da storici artigiani. I bracci metallici hanno terminali a sezione esagonale che reggono elementi in vetro che racchiudono all'interno frammenti di foglia oro 24KT in dispersione. Sotto ai bracci inferiori sono inseriti degli spot light. La lampada è rifinita in finitura oro opaco. Nella versione a 3 anelli il lampadario king size è perfetto per impreziosire ambienti importanti dalle ampie volumetrie. Illuminazione a LED.

Statuesque imposing chandelier, creating dreamlike light geometries among its hands bearing golden candles. Kali chandelier is the result of an artisan handcraft totally made in Murano island. Made of brass, its metal hands - esagonal shaped - hold up glass elements enclosing 24KT gold leaf particles. Under the below ring there are spot lights. Final finish matt gold. 3-rings model is a king size chandelier perfect for embellishing important halls with large volumes. LED lighting.

2 RINGS

TECHNICAL SHEET

KALI 2 RINGS

Light source: Power LED COB

Total power: 30 LED spot x 1W + 6 LED spot x 3W

Voltage: 230V

Rated luminous flux: 6300 lm

Colour temperature: 3000°K

Colour rendering index: Ra>80

Dimmer function: Yes - only for spots

Weight: Kg 100

Standard cable length: 2m

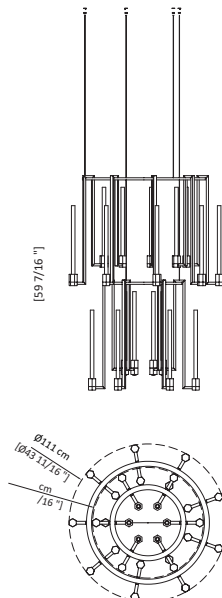

2 RINGS | ILL.KALI.210

Metal finish matt gold. Murano glass with 24KT golden leaf powder

3 RINGS

TECHNICAL SHEET

KALI 3 RINGS

Light source: Power LED COB

Total power: 58 LED spot x 1W + 6 LED spot x 3W

Voltage: 230V

Rated luminous flux: 10500 lm

Colour temperature: 3000°K

Colour rendering index: Ra>80

Dimmer function: Yes - only for spots

Weight: Kg 160

Standard cable length: 2m

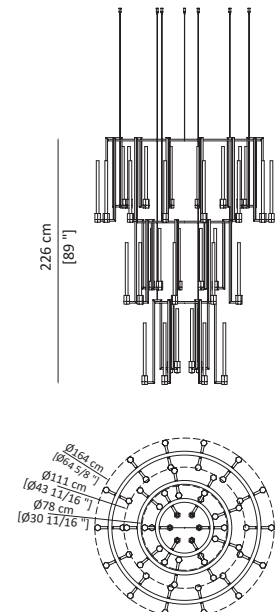

3 RINGS | ILL.KALI.220

Metal finish matt gold. Murano glass with 24KT golden leaf powder



Golden Cloud Suspension

DESIGN | PAOLO CASTELLI



Finishes of the above picture



Metal Finish
Matt Gold



Murano Glass with
24Kt golden leaf
powder

Prezioso lampadario interamente realizzato a mano secondo le più antiche tradizioni muranesi. Il corpo delle 22 “nuvole” (versione oval con 6 spot integrati) e 23 “nuvole” (versione round, con 5 spot integrati), disposte ad altezze sfalsate, è realizzato in vetro di Murano con un triplo passaggio di foglia d’oro e viene modellato a mano in stampo sagomato. La “nuvola” in vetro è agganciata a un corpo metallico in finitura oro satinato e alloggia al suo interno un moderno supporto a LED. Il corpo metallico è infine ancorato su una piastra in acciaio, verniciata opaca in bianco RAL 9016, nero RAL 9005, oro. È disponibile in due versioni: Oval e Round.

A refined chandelier made entirely by hand following the most ancient Murano traditions. The body of the 22 “clouds” (Oval version, with 6 built-in spotlights) and 23 “clouds” (Round version, with 5 built-in spotlights), arranged at staggered heights, is made of Murano glass with a triple pass of gold leaf and is formed by hand in a shaped mould. The glass “cloud” is attached to a metal body with a satin gold finish and houses a modern LED fitting. The metal body is anchored to a steel plate painted matt white RAL 9016, black RAL 9005, gold. Available in two versions: Oval and Round.

OVAL

TECHNICAL SHEET GOLDEN CLOUD OVAL

Light source: LED
Glass elements power: 3W x 22
Spots power: 18W (6 x 3W)
Voltage: 220-240V
Rated luminous flux: 5000 lm
Colour temperature: 2700°K
Colour rendering index: Ra>80
Dimmer function: Yes - only for spots
Weight: Kg 71
Standard cable length: 2m

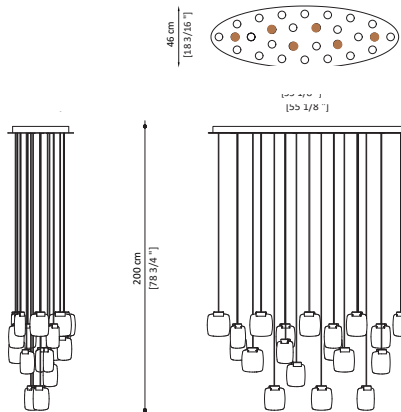

ROUND

TECHNICAL SHEET GOLDEN CLOUD ROUND

Light source: LED
Glass element power: 3W x 23
Spots power: 15W (5 x 3W)
Voltage: 220-240V
Rated luminous flux: 5000 lm
Colour temperature: 2700°K
Colour rendering index: Ra>80
Dimmer function: Yes - only for spots
Weight: Kg 59
Standard cable length: 2m

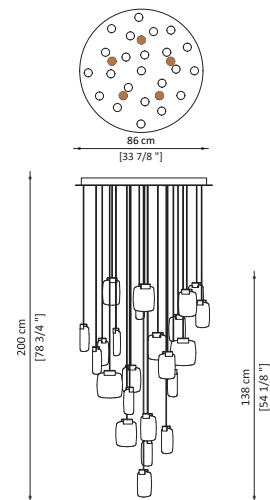

OVAL | ILL.GOLD.230

22 glass pendants and 6 built - in spotlights. Metal cap in matt gold finish
Murano glass with 24KT golden leaf powder

ROUND | ILL.GOLD.220

23 glass pendants and 5 built - in spotlights. Metal cap in matt gold finish
Murano glass with 24KT golden leaf powder



Golden Disc Suspension

DESIGN | PAOLO CASTELLI



Finishes of the above picture



Metal Finish
Matt Gold



Bovine
Leather
Col. 634
Oasi



Murano Glass with
24KT golden leaf
powder

Il disco di luce è un simbolo antico, universale e fonte infinita di ispirazione. La sua geometria perfetta e leggera, unita alla foglia oro 24KT, ne esalta la ricercata lavorazione artigianale. Golden Disc è una lampada a sospensione costituita da un elemento luminoso in vetro di Murano con un triplo passaggio di foglia d'oro, modellato a mano in stampo sagomato. Il vetro, che riflette la luce e la diffonde nell'ambiente, è incastonato in un disco di metallo finitura oro opaco satinato e sostenuto da un supporto metallico rivestito in pelle color oasi.

The disc of light is an ancient, universal symbol and never-ending source of inspiration. Its perfect, light geometry, combined with 24KT gold leaf, enhances its sophisticated craftsmanship. Golden Disc is a suspension lamp created with hand-moulded lighting element made of Murano glass, coated with three layers of gold leaf. The glass, which reflects the light and radiates it around the room, is set in a matt gold-finish metal disc and sustained by a metal support upholstered in oasi-coloured leather.

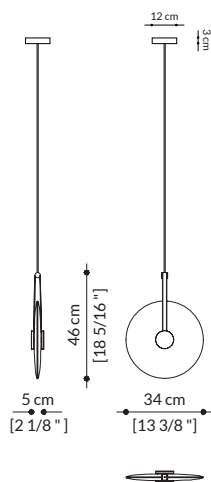

TECHNICAL SHEET
GOLDEN DISC
Light source: LED
Total power: 4W
Voltage: 220-240V
Rated luminous flux: 315 lm
Colour temperature: 3000°K
Colour rendering index: Ra>90
Dimmer function: No
Weight: Kg 10
Standard cable length: 2m

N.1 ELEMENT | ILL.DISC.200
Metal disc finished matt gold. Murano glass with 24KT golden leaf powder



Allure Suspension

DESIGN | PAOLO CASTELLI



Finishes of the above picture



Metal Finish
Matt Satin
Brass



Murano Glass with
24KT golden leaf
powder

La composizione Allure è un prezioso lampadario interamente realizzato a mano secondo le più antiche tradizioni muranesi. Il corpo delle 22 gocce (versione oval con 6 spot integrati) e 23 gocce (versione round, con 5 spot integrati), disposte ad altezze sfalsate, è realizzato in vetro di murano pieno, color cristallo veneziano, con incamiciata una preziosa foglia d'oro 24KT. La bossola superiore è in ottone, e alloggia un moderno supporto a LED. La bossola è infine ancorata su una piastra in acciaio, verniciata opaca in bianco RAL 9016, nero RAL 9005, oro. È disponibile nelle versioni Oval (6 spot LED), Round (5 spot LED) e Side.

The Allure is an exquisite lamp entirely handcrafted according to traditional murano techniques. The venetian crystal colour drops (n. 22 drops and 6 spots for oval version and n. 23 drops and 5 spots for round version), positioned at different heights, are made in solid murano glass enclosing precious 24KT gold leaf. In the gold finish, the top cap is made from brass and includes the modern LED light support. The top plate is anchored to a steel plate painted matt white RAL 9016, black RAL 9005, gold. It is available in versions: Oval with six integrated spots, Round with 5 integrated spots, and Side.

OVAL

TECHNICAL SHEET

ALLURE OVAL

Light source: Power LED
Glass elements power: 23,1W (22 x 1,05W)
Spots power: 18W (6 x 3W)
Voltage: 220-240V
Rated luminous flux: 5000 lm
Colour temperature: 3000°K
Colour rendering index: Ra83
Dimmer function: Yes - only for spots
Weight: Kg 90
Standard cable length: 2m

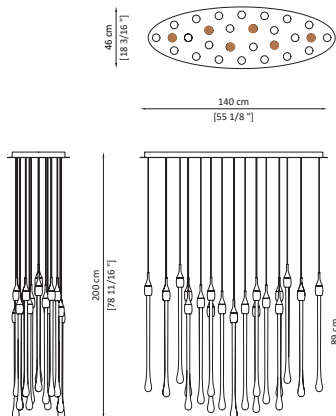

ALLURE OVAL | ILL.ALLU.230

22 glass pendants and 6 buit - in spotlights. Metal cap in satined brass
Murano glass with 24KT golden leaf powder

ROUND

TECHNICAL SHEET

ALLURE ROUND

Light source: Power LED
Glass elements power: 24,15W (23 x 1,05W)
Spots power: 15W (5 x 3W)
Voltage: 220-240V
Rated luminous flux: 2860 lm
Colour temperature: 3000°K
Colour rendering index: Ra83
Dimmer function: Yes - only for spots
Weight: Kg 90
Standard cable length: 2m

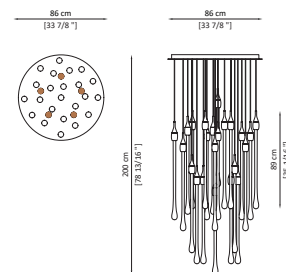

ALLURE ROUND | ILL.ALLU.220

23 glass pendants and 5 buit - in spotlights. Metal cap in satined brass
Murano glass with 24KT golden leaf powder



Vetro di Murano soffiato a mano, con polvee d'oro 24K totalmente realizzato a mano, ogni goccia è un pezzo unico.

Handblown Murano glass, 24K golden leaf powder. Any glass component is totally handmade so any item is unique.



Allure Side Suspension

DESIGN | PAOLO CASTELLI



Finishes of the above picture



Metal Finish
Matt Satin
Brass



Murano Glass with
24KT golden leaf
powder

La composizione Allure è un prezioso lampadario interamente realizzato a mano secondo le più antiche tradizioni muranesi. La versione Side ha 6 gocce realizzate in vetro di murano pieno, color cristallo veneziano, con incamiciata una preziosa foglia d'oro 24KT. La bossola superiore è in ottone e alloggia un moderno supporto a LED, ed è ancorata su una piastra in acciaio, verniciata opaca in bianco RAL 9016, nero RAL 9005, oro. La versione Side può avere su richiesta come optional Spot LED.

The Allure is an exquisite lamp entirely handcrafted according to traditional murano techniques. The Side version has 6 drops made in solid murano glass enclosing precious 24KT gold. The top cap is made from brass and includes the modern LED light support. The top plate is anchored to a steel plate painted matt white RAL 9016, black RAL 9005, gold. The Side version can have optional Spot Leds on request.

TECHNICAL SHEET

ALLURE SIDE

Light source: Power LED
Glass elements power: 6,30W (6 x 1,05W)
Voltage: 220-240V
Rated luminous flux: 2860 lm
Colour temperature: 3000°K
Colour rendering index: Ra83
Dimmer function: No
Weight: Kg 52
Standard cable length: 2m

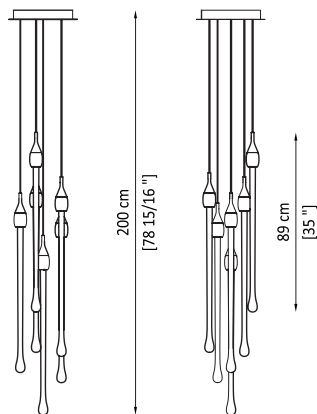
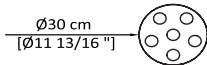

ALLURE SIDE | ILL.ALLU.200

6 glass pendants. Metal cap in satined brass. Murano glass with 24KT golden leaf powder



◀ Vetro di Murano soffiato a mano, con polvee d'oro 24K totalmente realizzato a mano, ogni goccia è un pezzo unico.

Handblown Murano glass, 24K golden leaf powder. Any glass component is totally handmade so any item is unique.



Joy Suspension

DESIGN | VITTORIO PARADISO



Finishes of the above picture



Metal Finish
Matt Satin
Brass



Murano Glass
Col. Amaranth

La composizione Joy nasce dal tema di dare corpo alla luce. La lampada è composta da tre anelli in ottone, ad altezza variabile, e sfere in vetro soffiato satinato bianco opaco (sfera grande) e rosso amaranth trasparente (sfera piccola) magicamente sospese all'interno della struttura metallica sottile. Un gioco di masse e di traiettorie circolari genera un disegno bilanciato di dinamiche gravitazionali. La luce emanata dalle sfere si diffonde sullo spazio circostante e irraggia il telaio. I riflessi dell'ottone contribuiscono a rendere l'atmosfera ancora più sofisticata e onirica. Disponibile la versione a un anello e a tre anelli.

Joy composition was born from the idea of giving form to light. The lamp is composed of three brass rings, with variable height, and spheres in hand-blown white satin glass (big sphere) and Amaranth see-through, (small sphere) magically suspended within a thin metal structure. The play of circular masses and trajectories generates a balanced design of gravitational dynamics. The light from the sphere is diffused into the surrounding space, illuminating the frame. The reflections of the brass render the luminous field visible by its aura. Available versions: one ring, three rings.

1 RING

TECHNICAL SHEET
JOY SUSPENSION 1 RING
Light source: LED
Total power: 1.9W
Voltage: 220-240V
Rated luminous flux: 204 lm
Colour temperature: 2700°K
Colour rendering index: Ra>80
Dimmer function: No
Weight: Kg 10
Standard cable length: 2m

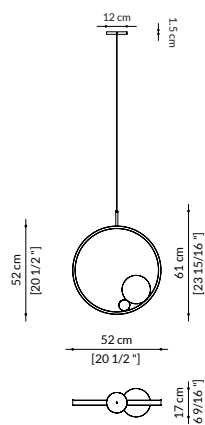

JOY 1 RING | ILL.JOYL.210

1 ceiling canopy. Matt brass ring. Lamp shades in hand-blown white satin glass
3 decorative glass spheres in Murano glass Col. Amaranth

3 RINGS

TECHNICAL SHEET
JOY SUSPENSION 3 RINGS
Light source: LED
Total power: 5.7W
Voltage: 220-240V
Rated luminous flux: 612 lm
Colour temperature: 2700°K
Colour rendering index: Ra>80
Dimmer function: No
Weight: Kg 15
Standard cable length: 2m

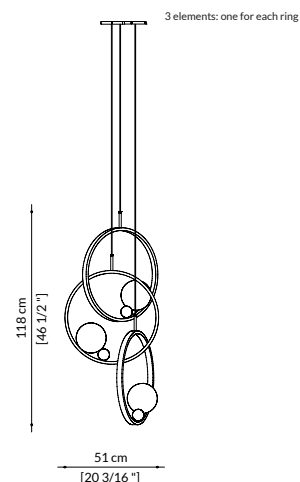

JOY 3 RINGS | ILL.JOYL.200

3 ceiling canopies. Matt brass rings. Lamp shades in in hand-blown white satin glass
Decorative glass sphere in Murano glass Col. Amaranth



Terminal Suspension

DESIGN | PAOLO CASTELLI



OUTDOOR COLLECTION



Finishes of the above picture



Metal Finish
Champagne



Ceramic
Sicilian
Col. White



Ceramic
Sicilian
Col. Blue

Alternative ceramic

Nuova lampada da esterno in versione sospesa e applique. Terminal ha una forma delicata e leggera che ricorda quella dei tradizionali isolatori. Il diffusore è composto da elementi sovrapposti in ceramica siciliana smaltata a mano. Al centro un corpo tubolare in acciaio traforato con finitura color champagne protegge la sorgente a LED IP67, resistente all'acqua e agli agenti esterni.

A new outdoor lamp in a suspended and applique version. Terminal lamp has a delicate and light shape reminding the one of the traditional insulators. The diffuser is made up of overlapping elements in hand-glazed Sicilian ceramic. In the center, a tubular body in perforated steel with a champagne-colored finish protects the IP67 LED source, is resistant to water and external agents.

TECHNICAL SHEET

TERMINAL

Light source: LED
Total power: 7W
Voltage: 220-240V
Rated luminous flux: 937 lm
Colour temperature: 3000°K
Colour rendering index: Standard CRI>80
Dimmer function: No
Weight: Kg 5
Standard cable length: 2m

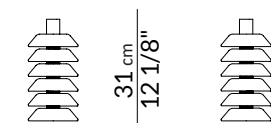

15 cm
5 15/16"



SUSPENSION OUTDOOR - CERAMIC | ILL.TERM.200

Overlapping hand-glazed Sicilian ceramic white or Blue. In the center, a tubular body in perforated steel with a champagne-colored finish protects the IP67 LED source

WALL

TECHNICAL SHEET

TERMINAL WALL

Light source: LED
Total power: 7W
Voltage: 220-240V
Rated luminous flux: 937 lm
Colour temperature: 3000°K
Colour rendering index: Standard CRI>80
Dimmer function: No
Weight: Kg 5

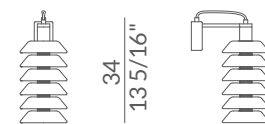

15
5 15/16"



34
13 5/16"

25
9 13/16"

WALL OUTDOOR - CERAMIC | ILL.TERM.500

Overlapping hand-glazed Sicilian ceramic white or Blue. In the center, a tubular body in perforated steel with a champagne-colored finish protects the IP67 LED source







Lampade a muro & Applique
Wall & Ceiling Lamps

My Lamp Wall

DESIGN | PAOLO CASTELLI

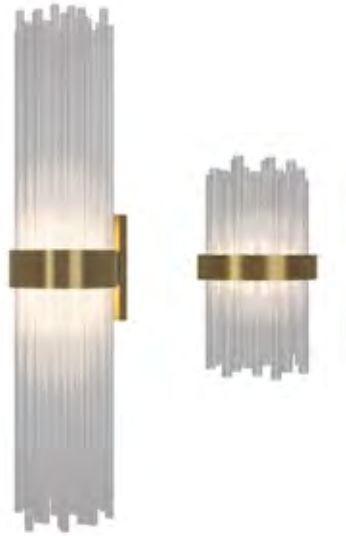

Finishes of the above picture



Metal Finish
Matt Gold

Alternative finishes



Metal Finish
Matt Black
Nickel

My Lamp Wall è una raffinata ed elegante lampada a parete che completa la collezione My Lamp. Si compone di un raffinato "bouquet" di tubi realizzati in vetro borosilicato veneziano e raccolti in una fascia metallica con finitura oro opaco o nichel nero opaco.

My Lamp Wall is a stylish and elegant wall lamp that completes the My Lamp collection. It composed of a considerable "bouquet" of tubes made of Venetian borosilicate glass placed at different heights and collected in a curved metal band, which is treated with a particular matt gold finish or matt black nickel finish.

SMALL

TECHNICAL SHEET
MY LAMP WALL
Light source: LED
Total power: 15W
Voltage: 100-240V
Rated luminous flux: 1300 lm
Colour temperature: 2700°K
Colour rendering index: Ra>80
Dimmer function: No
Weight: Kg 4

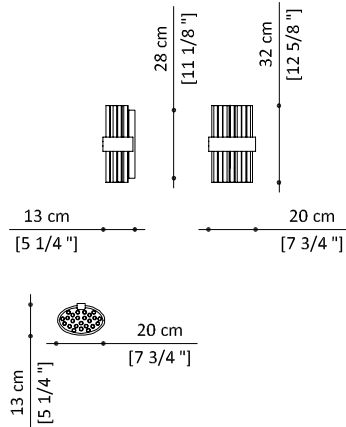

SMALL | ILL.MYLA.510

Metal band in matt gold finish. Transparent borosilicate glass tubes

SMALL BLACK NICKEL | ILL.MYLA.510.BN

Metal band in matt black nickel finish. Transparent borosilicate glass tubes

BIG

TECHNICAL SHEET
MY LAMP WALL BIG
Light source: Strip LED 15 W/M
Total power: 52W
Voltage: 220-240V
Rated luminous flux: 4760 lm
Colour temperature: 2700°K
Colour rendering index: Ra>80
Dimmer function: No
Weight: Kg 17

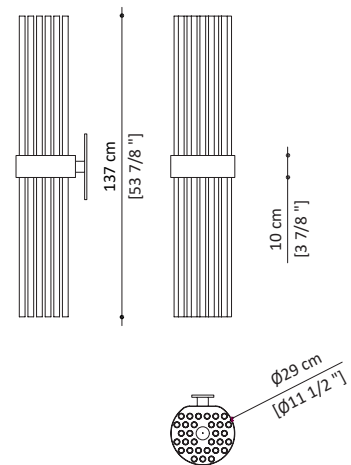

BIG | ILL.MYLA.520

Metal band in matt gold finish. Transparent borosilicate glass tubes

BIG BLACK NICKEL | ILL.MYLA.520.BN

Metal band in matt black nickel finish. Transparent borosilicate glass tubes



Kali Wall

DESIGN | PAOLO CASTELLI



Finishes of the above picture



Metal Finish
Matt Gold



Murano Glass with
24KT golden leaf
powder

Kali vanta una lavorazione creata interamente sulla isola di Murano da storici artigiani. Della collezione fa parte anche questa versione applique, realizzata con due bracci in metallo finitura oro opaco che sorreggono elementi in vetro di Murano con foglia d'oro 24KT all'interno, in dispersione.

Kali is the result of an artisal handcraft totally made on Murano island. The collection also includes this applique version, made with two metal arms in matt gold finish that support elements in Murano glass with 24KT gold leaf inside, in dispersion.

TECHNICAL SHEET

KALI WALL

Light source: 2 spot LED x 2W
Total power: 4W
Voltage: 230V
Rated luminous flux: 300 lm
Colour temperature: 3000°K
Colour rendering index: Ra80
Dimmer function: No
Weight: Kg 8

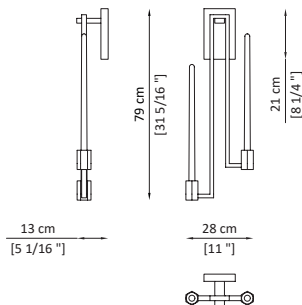

KALI WALL | ILL.KALI.500

Metal structure in matt gold. Murano glass with 24KT golden powder leaf

SINGLE

TECHNICAL SHEET

KALI WALL SINGLE

Light source: 2 spot LED
Total power: 2W
Voltage: 230V
Rated luminous flux: 150 lm
Colour temperature: 3000°K
Colour rendering index: Ra80
Dimmer function: No
Weight: Kg 4

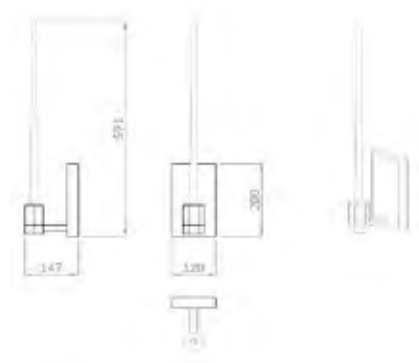

KALI WALL SINGLE | ILL.KALI.510

Metal structure in matt gold. Murano glass with 24KT golden powder leaf



Anodine Wall

DESIGN | PAOLO CASTELLI



Finishes of the above picture



Metal Finish
Matt Gold

Anodine Wall incarna l'eleganza di una lampada a parete che trasforma la luce in un'opera d'arte, richiamando il concetto di "forma non forma" attraverso una stilizzazione unica della luce. Con un tocco artistico d'eccellenza, arricchisce l'ambiente circostante, offrendo non solo illuminazione, ma anche un'esperienza estetica senza pari. La composizione consta di 11 elementi, ognuno dei quali è a forma di foglia in metallo, realizzato asimmetricamente a mano da esperti artigiani con finitura oro satinato. Nel modulo fisso a 8 elementi, 3 sono dotati di LED da 2W ognuno. La composizione è completata da 3 elementi singoli, da disporre a piacere per creare infinite combinazioni. La preziosità della lavorazione artigianale rende ogni pezzo della collezione unico nel suo genere.

Anodine Wall is a gracious wall lamp that transforms light into a work of art, recalling the concept of "shape does not form" through a unique stylization of light. With an artistic touch of excellence, it enriches the surrounding environment, offering not only lighting, but also an unparalleled aesthetic experience. The composition consists of 11 elements, each of which is shaped like a metal leaf, made asymmetrically by hand by expert craftsmen with a satin gold finish. In the fixed module with 8 elements, 3 are equipped with 2W LEDs each. The composition is completed by 3 individual elements, to be arranged at will to create infinite combinations. The preciousness of craftsmanship makes each piece of the collection unique.

TECHNICAL SHEET
ANODINE WALL
Light source: LED COB 1.1W x3
Total power: 3.3W
Voltage: 220-240V
Rated luminous flux: 1200 lm
Colour temperature: 3000 °K
Colour rendering index: Ra80
Dimmer function: No
Weight: Kg 0,197

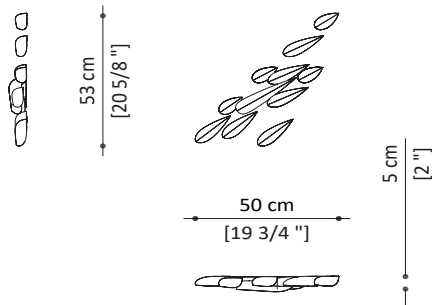

ANODINE WALL | ILL.ANOD.510
11 elements in matt gold finish

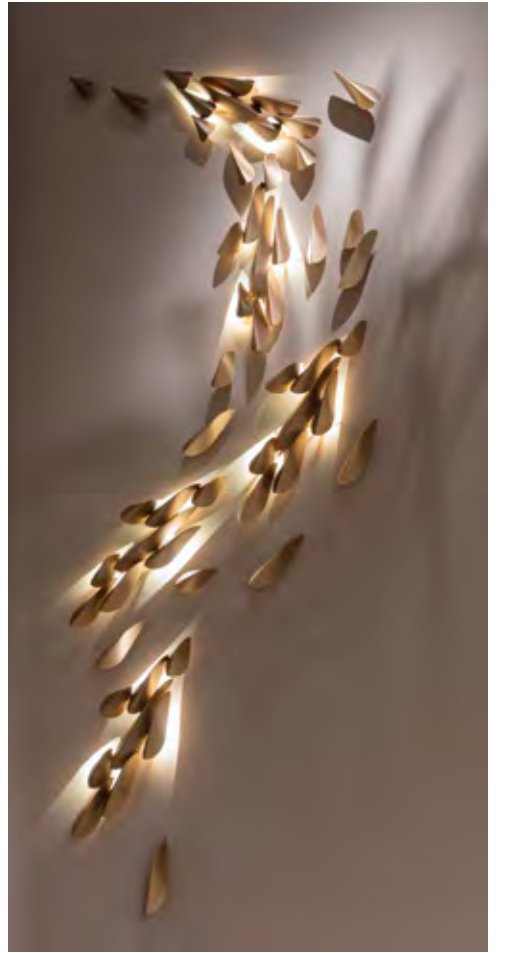

Anodine Circle Wall

DESIGN | PAOLO CASTELLI



Finishes of the above picture



Metal Finish
Matt Gold



Polished
brass



Metal
Varnish
Grey

Anodine Circle si presenta come una scultura che cattura e riflette le sottili sfumature della luce naturale durante il giorno. Questa lampada, con un marcato richiamo artistico, si integra perfettamente negli ambienti caratterizzati da una personalità ricercata. Composta da numerosi elementi luminosi in metallo dall'affascinante finitura oro opaco satinato, verniciati artigianalmente, è unita da un sottile filo d'acciaio che crea un effetto di fluttuazione attorno alla sua centrale lente riflettente, realizzata in metallo specchiato con finitura oro lucido.

Anodine Circle looks like a sculpture that captures and reflects the subtle nuances of natural light during the day. This lamp, with a marked artistic appeal, integrates perfectly in the environments characterized by a refined personality. Composed of numerous bright metal elements with a charming satin matt gold finish, hand painted, it is joined by a thin steel wire that creates a floating effect around its central reflective lens, made of mirrored metal with polished gold finish.

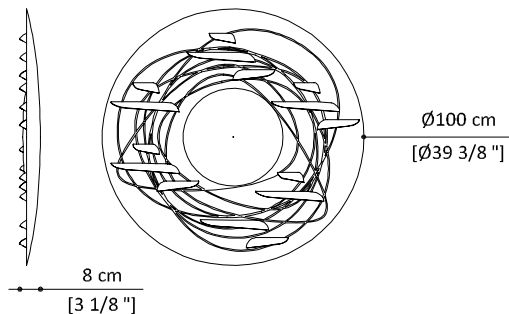

TECHNICAL SHEET
ANODINE CIRCLE WALL
Light source: Strip LED 8 W/M + LED COB 36W
Total power: 43,2W
Voltage: 115-230V
Rated luminous flux: 4785 lm
Colour temperature: 2700°K
Colour rendering index: Ra80/85
Dimmer function: No
Weight: Kg 17

ANODINE CIRCLE WALL | ILL.ANOD.500
Grey matt varnished plate with inner polished bronzed element
Details in matt gold finish



Labilis

Wall

DESIGN | PAOLO CASTELLI



Finishes of the above picture

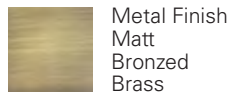

Tre anelli di diverso diametro installabili a parete singolarmente o in composizione libera. L'anello in metallo è finitura nero opaco con diffusore di luce LED in policarbonato opalino bianco perimetrale. Ogni anello è fissato a parete da un cilindro metallico in finitura bronzo ottone opaco e da due distanziatori in metallo finitura nero opaco. Alimentatore remoto. Optionals su richiesta: anelli dimmerabili.

Three rings of different diameters that can be installed on the wall individually or in a random composition. The metal ring has a matt black finish with a white opal polycarbonate LED light diffuser around the perimeter. Each ring is fixed to the wall by a metal cylinder in matt brass bronze finish and by two metal spacers in matt black finish. Remote power supply. Optionals on request: dimmable rings.

Ø27

TECHNICAL SHEET

LABILIS Ø27

Light source: Strip LED 140 LED/m
Total power: 7,3W - Strip LED 14,4W/m
Voltage: 230V
Rated luminous flux strip LED: 1092 lm
Colour temperature: 2700°K
Colour rendering index: 90
Dimmer function: Yes
Weight: Kg 3

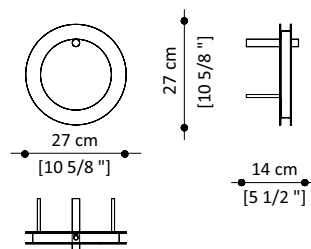

WALL RING Ø27 | ILL.LABI.530

1 ring Ø27 in metal matt black varnished. Metal cylinder in matt bronzed brass.
Remote drivers

Ø43

TECHNICAL SHEET

LABILIS Ø43

Light source: Strip LED 140 LED/m
Total power: 9,7W - Strip LED 14,4W/m
Voltage: 230V
Rated luminous flux strip LED: 1755 lm
Colour temperature: 2700°K
Colour rendering index: 90
Dimmer function: Yes
Weight: Kg 4

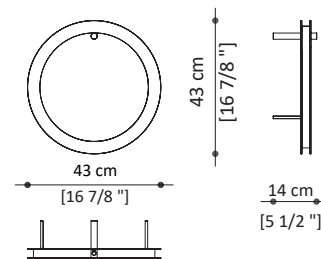

WALL RING Ø43 | ILL.LABI.520

1 ring Ø43 in metal matt black varnished. Metal cylinder in matt bronzed brass.
Remote drivers



Ø70

TECHNICAL SHEET

LABILIS Ø70

Light source: Strip LED 140 LED/m
 Total power: 13,6W - Strip LED 14,4W/m
 Voltage: 230 V
 Rated luminous flux strip LED: 2857 lm
 Colour temperature: 2700°K
 Colour rendering index: 90
 Dimmer function: Yes
 Weight: Kg 6

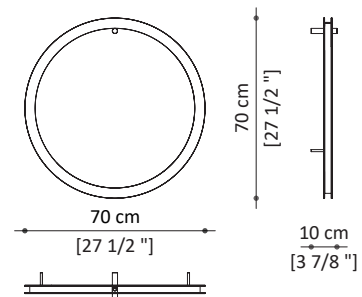

WALL RING Ø70 | ILL.LABI.510

1 ring Ø70 in metal matt black varnished. Metal cylinder in matt bronzed brass
 Remote drivers

Origami Wall

DESIGN | PAOLO CASTELLI



Finishes of the above picture



Metal
Varnish
Black
RAL 9004



Polished
brass



Metal Finish
Matt Satin
Brass

Una bellezza sottile, una luce piena e mai invadente che illumina l'ambiente evocando atmosfere lontane. La lampada a parete Origami, si contraddistingue per il tratto contemporaneo e longilineo delle sue singole componenti formate ognuna da due elementi: la struttura in doppia finitura, oro opaco satinato e nero opaco, viene attraversata da un'asta in ottone contenente la sorgente di luce a LED. Combinati tra loro, i raggi formano un ventaglio di luce che anima lo spazio donando movimento alla parete. La particolarità del suo design, permette ad Origami di dare vita a molteplici composizioni grafiche, rivelando il suo carattere fortemente decorativo, anche a luci spente.

A subtle beauty, a full and never intrusive light that illuminates the room, evoking distant atmospheres. The Origami wall lamp is characterised by the contemporary and long-linear design of its individual components, each consisting of two elements: the structure in a double finish, satin matt gold and matt black which is crossed by a brass rod containing the LED light source. Combined, the beams form a fan of light that animates the space, giving movement to the wall. The uniqueness of its design allows Origami to create multiple graphic compositions, revealing its highly decorative character, even when the lights are off.

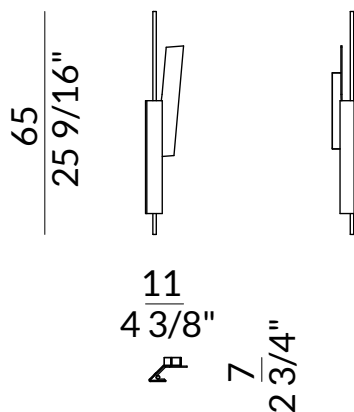

TECHNICAL SHEET

ORIGAMI WALL

Light source: LED

Total power: 6W

Voltage: 24V

Rated Luminous Flux: 600

Colour temperature: 3000°K

Rendering Index: Standard CRI 90

Dimmer function: No

ORIGAMI WALL LAMP | ILL.ORIG.510

Metal lamp finishes in matt black and matt gold and polished brass rod



◀ La struttura in doppia finitura, oro opaco satinato e nero opaco, viene attraversata da un'asta in ottone contenente la sorgente di luce a LED.

The structure in a double finish, satin matt gold and matt black, is crossed by a brass rod containing the LED light source.



Fair Wall

DESIGN | PAOLO CASTELLI



Finishes of the above picture



Metal
Varnish
Black
RAL 9004



Metal Finish
Matt
Bronzed
Brass

Fair è un corpo illuminante da parete costituito da un doppio binario di tubolari in metallo finitura nero opaco con diffusore in policarbonato opalino. La struttura di ancoraggio alla parete, che incorpora il driver, è in metallo finitura bronzo ottone opaco. L'apparecchio può essere montato sia in verticale che in orizzontale garantendo alla sorgente luminosa lineare un'ampia capacità di espressione, fornendo allo spazio energia e carattere.

Fair is a wall lamp consisting of a double tubular metal rail with opal polycarbonate diffuser. The anchor structure to the wall, which incorporates the driver, is in matte brass bronze finish metal. The luminaire can be mounted both vertically and horizontally, providing the linear light source with a wide expression capacity, providing energy and character to the space.

L60

TECHNICAL SHEET

FAIR WALL 60

Light source: Strip LED

Total power: 14,4W

Voltage: 24V

Rated luminous flux: 1760 lm

Colour temperature: 2700°K

Colour rendering index: Ra>80

Dimmer function: No

Weight: Kg 2

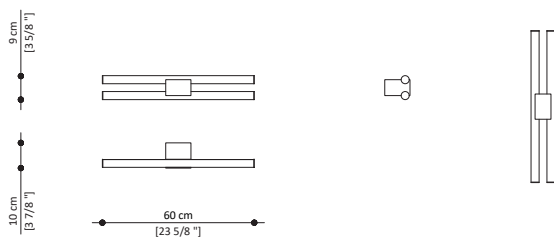

L60 | ILL.FAIR.510

Metal elements in black matt finish. Details in metal matt bronzed brass finish

L110

TECHNICAL SHEET

FAIR WALL 110

Light source: Strip LED

Total power: 28.8W

Voltage: 24V

Rated luminous flux: 1760 lm

Colour temperature: 2700°K

Colour rendering index: Ra>80

Dimmer function: No

Weight: Kg 3

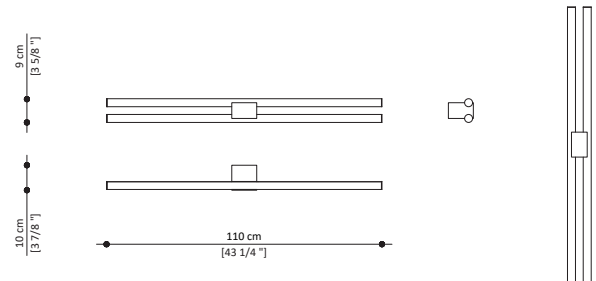

L110 | ILL.FAIR.520

Metal elements in black matt finish. Details in metal matt bronzed brass finish



Golden Disc Wall

DESIGN | PAOLO CASTELLI



Finishes of the above picture



Metal Finish
Matt Gold



Murano Glass with
24KT golden leaf
powder

Preziosa lampada a parete interamente realizzata a mano secondo le più antiche tradizioni muranesi. L'elemento, realizzato in vetro di Murano con un triplo passaggio di foglia d'oro 24KT, è agganciato a un corpo metallico in finitura oro opaco che alloggia al suo interno la sorgente LED e il proprio driver.

A precious wall lamp entirely handmade according to the most ancient Murano traditions. The element, made of Murano glass with a triple passage of 24KT gold leaf, is hanged on the wall thanks to a metal body in matt gold finish which hosts the LED source and its driver inside.

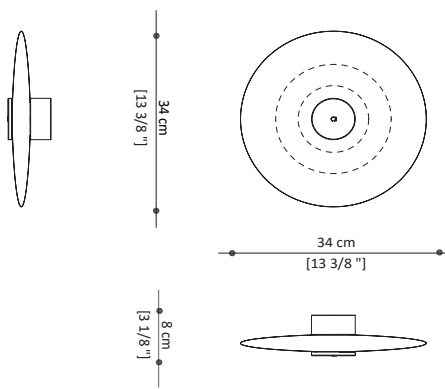

TECHNICAL SHEET
GOLDEN DISC WALL
Light source: LED
Total power: 4W
Voltage: 220-240V
Rated luminous flux: 315 lm
Colour temperature: 3000°K
Colour rendering index: Ra>90
Dimmer function: No
Weight: Kg 10

GOLDEN DISC WALL | ILL.DISC.500
Metal disc in matt gold finish. Murano glass with 24KT golden powder leaf

Golden Cloud Wall

DESIGN | PAOLO CASTELLI



Finishes of the above picture



Metal Finish
Matt Gold



Murano Glass with
24KTgolden leaf
powder

Preziosa lampada a parete interamente realizzata a mano secondo le più antiche tradizioni muranesi. L'elemento, realizzato in vetro di murano con un triplo passaggio di foglia d'oro 24KT, è agganciato a un corpo metallico in finitura oro opaco che alloggia al suo interno la sorgente LED e il proprio driver.

Precious wall lamp entirely handmade according to the most ancient Murano traditions. The element, made of Murano glass with a triple passage of 24KT gold leaf, is hanged to a metal body in matt gold finish which hosts the LED source and its driver inside.

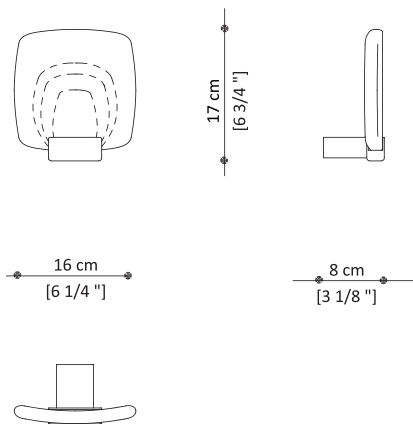

TECHNICAL SHEET
GOLDEN CLOUD WALL
Light source: LED
Total power: 3W
Voltage: 220-240 V
Rated luminous flux: 5000 lm
Colour temperature: 2700°K
Colour rendering index: Ra>80
Dimmer function: No
Weight: Kg 2
Package weight: Kg 8

GOLDEN CLOUD WALL | ILL.GOLD.500
Lampshade in Murano glass with 24KT golden powder leaf
Metal body in matt gold finish

Circle Wall

DESIGN | PAOLO CASTELLI



Finishes of the above picture



Metal Finish
Polished
Gold



Metal
Varnish
Bronze



Metal
Varnish
Ivory
RAL 9010

Circle è una lampada da parete decorativa di grandi dimensioni che si ispira alle forme morbide e sinuose degli anni '40. Realizzata con maestria, presenta un grande disco leggermente concavo in metallo martellato a mano e rifinito a specchio in vari colori. Al centro del disco, come una goccia, spicca una mezza sfera in metallo specchiato con una luminosa finitura oro lucido. Ogni pezzo della collezione è unico, grazie alla pregiata lavorazione artigianale che conferisce loro un carattere distintivo.

Circle is a large decorative wall lamp that is inspired by the soft and sinuous shapes of the 40s. Made with craftsmanship, it features a large disc slightly concave metal hammered by hand and mirror finished in various colors. In the center of the disc, like a drop, a half-sphere in mirrored metal stands out with a bright polished gold finish. Each piece of the collection is unique, thanks to the fine craftsmanship that gives them a distinctive character.

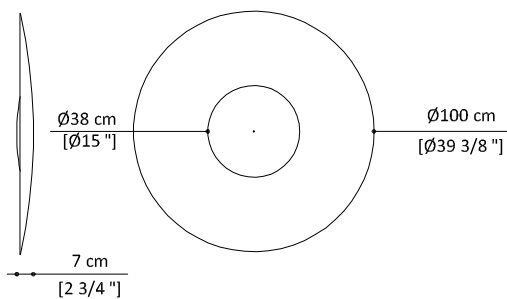

TECHNICAL SHEET
CIRCLE LAMP
Light source: Strip LED 8 W/M
Total power: 72W
Voltage: 230V
Rated luminous flux: 585 lm
Colour temperature: 2700°K
Colour rendering index: Ra85
Dimmer function: No
Weight: Kg 15

CIRCLE LAMP | ILL.CIRC.500
Matt varnished disc with polished gold diffuser



◀ Grande disco leggermente concavo in metallo battuto a mano.

Slightly concave large disc made of metal hammered by hand.



Joy Wall

DESIGN | VITTORIO PARADISO



Finishes of the above picture



Metal Finish
Matt Satin
Brass



Murano Glass
Col. Amaranth

Joy nasce dall'idea di incarnare la luce attraverso la materia. Questa lampada presenta un anello in ottone che accoglie sfere di vetro soffiato satinato: una grande in bianco opaco e una piccola in rosso amaranth. Queste sfere sono magicamente sospese all'interno di una struttura metallica sottile, creando un gioco di masse e traiettorie circolari che generano un disegno bilanciato di dinamiche gravitazionali. La luce che si sprigiona dalle sfere si diffonde nello spazio circostante, irradiando il telaio e creando un'atmosfera sofisticata e onirica, enfatizzata dai riflessi dorati dell'ottone.

Joy was born from the idea of embodying light through matter. This lamp has a brass ring that holds blown glass spheres: a large matt white and a small amaranth red. These spheres are magically suspended within a thin metal structure, creating a play of masses and circular trajectories that generate a balanced design of gravitational dynamics. The light that emanates from the spheres diffuses into the surrounding space, radiating the frame and creating a sophisticated and dreamlike atmosphere, emphasized by the golden reflections of brass.

TECHNICAL SHEET

JOY WALL

Light source: LED

Total power: 1.9W

Voltage: 220-240V

Rated luminous flux: 204 lm

Colour temperature: 2700°K

Colour rendering index: Ra>80

Dimmer function: No

Weight: Kg 10

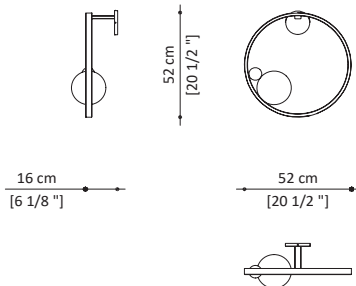

JOY WALL | ILL.JOYL.500

Matt brass ring. Lamp shade in hand-blown white satin glass.
Decorative glass sphere in Murano glass Col. Amaranth



◀ Sfera decorativa in vetro soffiato a bocca da artigiani muranesi.

Decorative sphere made of glass-blowing Murano technique.



Galaxy Wall

DESIGN | PAOLO CASTELLI



Finishes of the above picture



Metal Finish
Polished
Gold



Metal Finish
Matt Bronzed
Brass

Galaxy è lampada da parete che, con le sue forme e riflessi, si trasforma in una vera e propria scultura luminosa. È costituita da lenti convessi dall'elegante finitura oro lucido, accoppiate a dischi in metallo dal bronzo ottone opaco. Le superfici lisce e convessi conferiscono dinamicità allo spazio circostante, creando un effetto visivo affascinante e suggestivo.

Galaxy is a wall lamp that, with its shapes and reflections, is transformed into a real luminous sculpture. It consists of convex lenses with an elegant polished gold finish, coupled with metal discs with matt brass bronze. The smooth and convex surfaces give dynamism to the surrounding space, creating a fascinating and suggestive visual effect.

TECHNICAL SHEET

GALAXY WALL

Light source: N. 2 LED modules 22W - N. 4 LED modules 11W

Total power: 88W

Voltage: 230V

Rated luminous flux: 4880 lm

Colour temperature: 2700°K

Colour rendering index: Ra85

Dimmer function: No

Weight: Kg 22

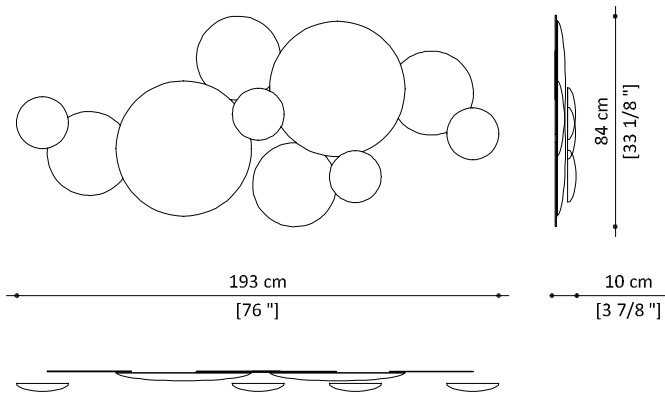

GALAXY | ILL. GALA.500

Lens in matt polished gold finish. Discs in matt bronzed brass finish



◀ Galvanica: prezioso processo di trattamento dell'ottone in grado di conferire allo stesso un'inaspettata tridimensionalità.

Galvanic: precious treatment of the brass able to give it an unexpected three-dimensionality.



My Lamp Ceiling

DESIGN | PAOLO CASTELLI



Finishes of the above picture



Metal Finish
Matt Gold

Alternative finishes



Metal Finish
Matt Black
Nickel

My Lamp Ceiling è una plafoniera circolare fortemente scenografica, che attraverso le diverse altezze dei vetri illuminati crea un decoro dinamico e raffinato. È composta da un importante "bouquet" di tubi realizzati in vetro borosilicato veneziano e raccolti in una fascia metallica curvata, trattata con particolare finitura oro opaco o nichel nero opaco. Il telaio portante interno è realizzato in metallo nichelato. Disponibile in due misure.

My Lamp Ceiling is a round lamp with a great visual impact, which gives the room a dynamic and elegant touch thanks to the different heights of the lit glass elements. It comprises a considerable "bouquet" of venetian borosilicate glass tubes bound together by a curved metal band in matt gold finish or matt black nickel finish. The internal supporting frame is made of nickel-plated metal. Available in two sizes.

Ø100

TECHNICAL SHEET
MY LAMP CEILING Ø100
Light source: STRIP LED 8W/M
Total power: 60,5W
Voltage: 115-230V
Rated luminous flux: 4615 lm
Colour temperature: 2700°K
Colour rendering index: Ra80
Dimmer function: Yes
Weight: Kg 120

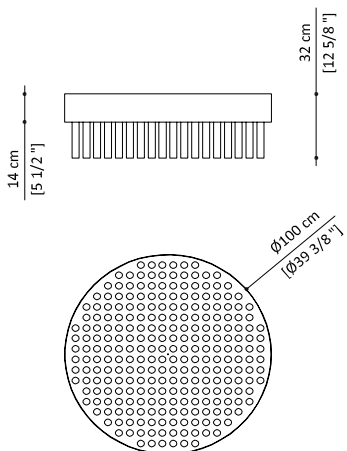

CEILING ROUND 100 | ILL.MYLA.300
Metal band in matt gold finish. Transparent borosilicate glasses

CEILING ROUND 100 BLACK NICKEL | ILL.MYLA.300.BN
Metal band in matt black nickel finish. Transparent borosilicate glasses

Ø140

TECHNICAL SHEET
MY LAMP CEILING Ø140
Light source: STRIP LED 11W/M
Total power: 108W
Voltage: 110-230V
Rated luminous flux: 11.500 lm
Colour temperature: 2700°K
Colour rendering index: Ra80
Dimmer function: Yes
Weight: Kg 180

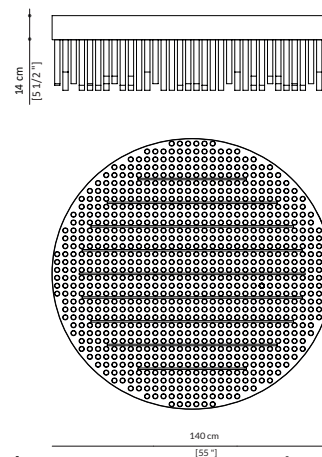

CEILING ROUND 140 | ILL.MYLA.302
Metal band in matt gold finish. Transparent borosilicate glasses

CEILING ROUND 140 BLACK NICKEL | ILL.MYLA.302.BN
Metal band in matt black nickel finish. Transparent borosilicate glasses



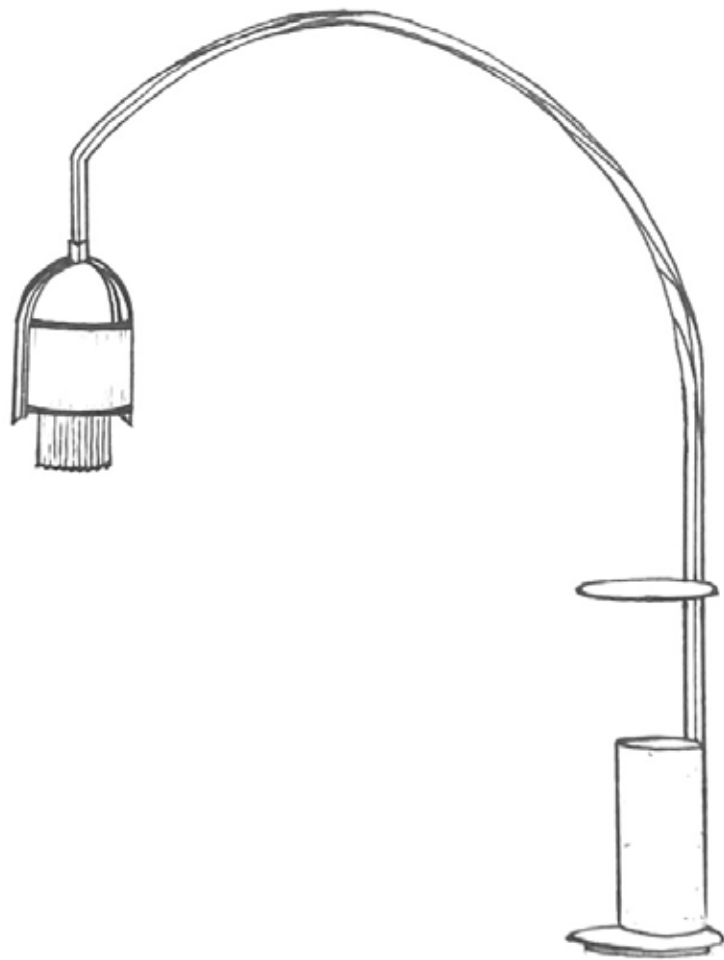



Lampade da terra
Floor Lamps

Inspiration

Soreluna Floor

DESIGN | PAOLO CASTELLI



Finishes of the above picture



Metal Finish
Matt Gold



Metal Painting
Black Matt

Lampada ancorata a soffitto composta da un cavo tirante centrale e contrappeso a terra realizzato in metallo verniciato nero opaco. Il cavo tirante centrale monta tre lampade coniche realizzate in metallo, con finitura oro opaco ed emissione luminosa con piastrine LED circolari. Il rosone a soffitto è sempre di forma conica, in metallo finitura oro opaco. Su richiesta disponibile anche il fissaggio a parete.

Lamp anchored to the ceiling, consisting of a central tie-rod cable and a ground counterweight made of metal in varnished matt black finish. The central pull cable mounts three conical lamps made of metal, with a matt gold finish and the light is emitted thanks to circular LED plates. The ceiling rose is always conical in shape, in metal with a matt gold finish. On request it's available with optional wall bracket.

optional
WALL BRACKET



11 cm
4 3/16"



19 cm
7 5/16"

3 cm
1 3/16"

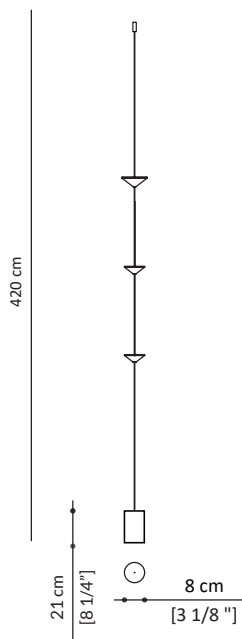

TECHNICAL SHEET
SORELUNA FLOOR
Light source: Board LED Ø80 (3X)
Total power: 15,6W - Board 5,2W (3X)
Voltage: 220-240V
Rated luminous flux: 2538 lm - (846Lm X3)
Colour temperature: 3000°K
Colour rendering index: >80
Dimmer function: No
Plug Cables Lenght: 2,5 mt
Light source cables lenght: 4mt
Weight: 3,5 Kg

SORELUNA | ILL.SORE.100

3 caps in matt gold finish - metal cable. Metal basement in varnished matt black finish



Manta Floor

DESIGN | VITTORIO PARADISO



Finishes of the above picture



Murano Glass
Col. Fumè
Hand-forged



Natural
Brass

Alternative finish



Murano Glass
Col. Amber
Hand-forged

Piegare la materia all'arte, una lampada da terra che assume le sembianze di una foglia che volteggia leggera nell'ambiente. La famiglia di lampade Manta accoglie le versioni da sospensione e da tavolo, ampliando la proposta di sistemi di illuminazione caratterizzati da un'eterea leggerezza e sobria eleganza. La sorgente di luce a LED, una raffinata foglia in vetro color fumè o ambra, forgiata a mano dai maestri vetrai di Murano, illumina l'ambiente con grande calore e naturalezza, dando vita ad un'atmosfera avvolgente e di assoluta armonia.

Bending the matter to make art, a floor lamp that takes on the appearance of a leaf that twirls lightly in the ambience. The Manta family of lamps welcomes the floor and the table versions, expanding the range of lighting systems characterised by ethereal lightness and understated elegance. The LED light source, a refined fumè or amber coloured glass leaf, hand-forged by master glassmakers in Murano, illuminates the room with great warmth and naturalness, creating an enveloping atmosphere of absolute harmony.

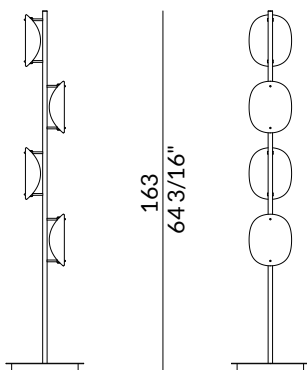

35
13 3/4"



TECHNICAL SHEET

MANTA FLOOR

Light source: LED
Total power: 10W
Voltage: 220-240V
Rated Luminous Flux: 800 lm
Colour temperature: 3000°K
Color Rendering Index: Standard CRI>80
Dimmer function: No

MANTA FLOOR LAMP AMBRA | ILL.MANT.100

Ambra colored glass leaf, hand-forged in Murano, encapsulated in a cylindrical satin brass structure which contains the LED light source.

MANTA FLOOR LAMP FUMÈ | ILL.MANT.101

Fumè colored glass leaf, hand-forged in Murano, encapsulated in a cylindrical satin brass structure which contains the LED light source



◀ Una raffinata foglia in vetro color Fume o ambra, forgiata a mano dai maestri vetrai di Murano.

A refined Fume or amber coloured glass leaf, hand-forged by master glassmakers in Murano.



My Lamp Floor

DESIGN | PAOLO CASTELLI



Finishes of the above picture



Metal Finish
Matt Gold

Alternative finishes



Metal Finish
Matt Black
Nickel

My Lamp Floor è un'elegante aggiunta agli spazi domestici, caratterizzata da forme raffinate e una luce che contribuisce a creare un'atmosfera accogliente. Grazie alla sua versatilità, può essere posizionata singolarmente o in coppia per ottenere una simmetria perfetta, arricchendo e definendo l'ambiente circostante. È realizzato con una base e struttura in metallo, in finitura oro opaco o nichel nero opaco e tubi cilindrici aperti realizzati in vetro borosilicato veneziano.

My Lamp Floor is an elegant addition to domestic spaces, characterized by refined shapes and a light that contributes to creating a cozy atmosphere. Thanks to its versatility, it can be placed individually or in pairs to obtain a perfect symmetry, enriching and defining the surrounding environment. It is made with a metal base and structure, in matt gold or matt black nickel finish and open cylindrical tubes made of Venetian borosilicate glass.

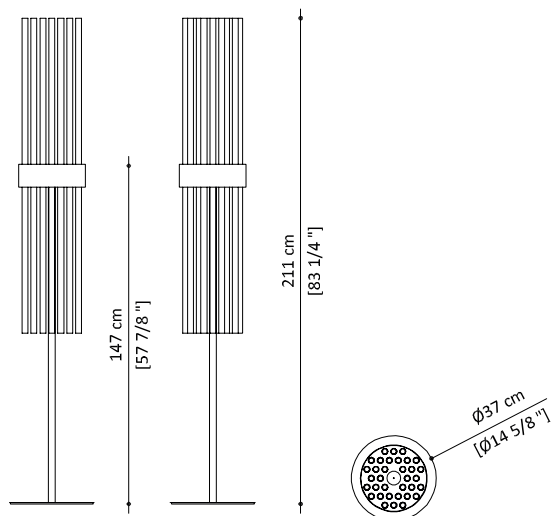

TECHNICAL SHEET

MY LAMP FLOOR

Light source: 4 LED modules

Total power: 35W

Voltage: 240V

Rated luminous flux: 2600 lm

Colour temperature: 2700°K

Colour rendering index: Ra80

Dimmer function: No

Weight: Kg 39

MY LAMP FLOOR | ILL.MYLA.100

Metal band in matt gold finish. Transparent borosilicate glass tubes

MY LAMP FLOOR BLACK NICKEL | ILL.MYLA.100.BN

Metal band in matt black nickel finish. Transparent borosilicate glass tubes



Fanus Floor

DESIGN | PAOLO CASTELLI



Finishes of the above picture

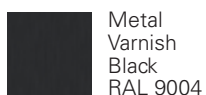

Metal
Varnish
Black
RAL 9004



Natural
Brass



Leather
Cuio
Col. 26
Natural



Murano Glass
Transparent
Blown ribbed



Murano Glass
Col. Amber
Hand-forged



Fabric
Natural
Col. Ivory

Alternative lampshade

Una lampada a terra dalla struttura ad arco pensata per illuminare lo spazio e regalare l'intimità dell'ombra. La famiglia Fanus reinterpreta il concetto di lanterna, distinguendosi per i dettagli in cuoio naturale che impreziosiscono l'intera figura. Fanus è disponibile anche in versione a sospensione e da tavolo. Lampada da terra con dettagli in cuoio naturale con cavo e interruttore a pedale. Base in travertino. Il corpo lampada è in metallo verniciato di nero. Il corpo illuminante è in vetro cannettato trasparente con sorgente luminosa LED. Il paralume è disponibile in due versioni: in tessuto o in vetro di Murano curvato color ambra con parti metalliche verniciate di nero.

A floor lamp with an arched structure designed to illuminate the space and provide the intimacy of shadows. The Fanus family reinterprets the concept of a lantern, distinguished by natural leather details that embellish the entire design. Fanus is also available in pendant and table lamp versions. Floor lamp with natural leather details, equipped with a cable and foot switch. Travertine base. The lamp body is made of black painted metal. The lighting element is made of transparent ribbed glass with LED light source. The lampshade is available in two versions: fabric or curved Murano glass in amber color with black painted metal parts.

TECHNICAL SHEET

FANUS FLOOR

Light source: CC LED

Total power: 16,6W

Input Voltage(driver): 220-240V

Rated luminous flux: 1800 lm

Colour temperature: 3000°K

Colour rendering index: 80

Dimmer function: No

Weight with glass (excluding marble): 41 Kg

Weight with lampshade (excluding marble): 39 Kg

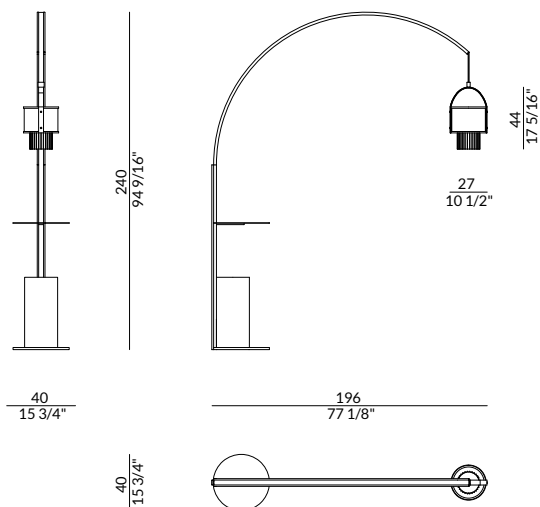

FANUS FLOOR LAMP GLASS | ILL.FANU.100

Structure in black metal with brass details, blown ribbed glass, lampshade in glass Col. Amber

FANUS FLOOR LAMP FABRIC | ILL.FANU.101

Structure in black metal with brass details, blown ribbed glass, lampshade in fabric Col. Ivory



Anodine Floor

DESIGN | PAOLO CASTELLI



Finishes of the above picture



Metal Finish
Matt Gold



Polished
brass

Anodine Floor è una lampada che trasforma la luce in una vera scultura, richiamando il concetto di "forma non forma" stilizzata della luce e donando un tocco artistico di eccellenza all'ambiente. È composta da 13 lunghi steli in ottone lucido, saldamente ancorati a una base metallica quadrata. Alcuni di questi steli sono abbelliti da foglie asimmetriche in metallo, realizzate a mano da abili artigiani e decorate con una finitura oro opaco satinato. La base stessa è rifinita con un'elegante finitura oro opaco satinato. La lampada si presta perfettamente a essere posizionata in coppia, creando una simmetria armoniosa nello spazio circostante. Ogni pezzo di questa collezione è unico nel suo genere grazie alla preziosa lavorazione artigianale impiegata nella sua creazione.

Anodine Floor is a lamp that transforms light into a real sculpture, recalling the concept of "shape not shape" stylized light and giving an artistic touch of excellence to the environment. Consists of 13 long stems in polished brass, firmly anchored to a square metal base. Some of these stems are embellished with asymmetrical metal leaves, handmade by skilled craftsmen and decorated with a satin matt gold finish. The base itself is finished with an elegant satin matt gold finish. The lamp lends itself perfectly to being placed in pairs, creating a harmonious symmetry in the surrounding space. Each piece of this collection is unique thanks to the precious craftsmanship used in its creation.

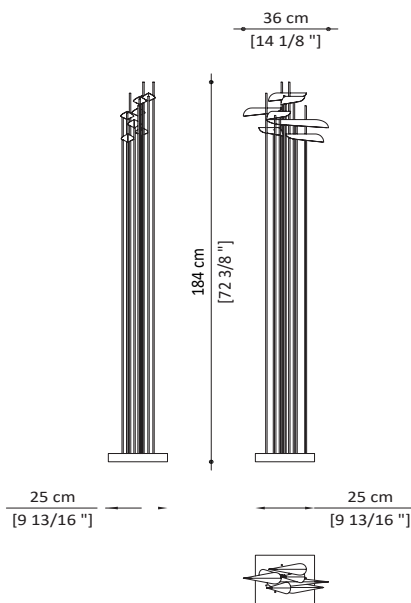

TECHNICAL SHEET
ANODINE FLOOR
Light source: Power LED COB
Total power: 24,5W
Voltage: 54V
Rated luminous flux: 2765 lm
Colour temperature: 3000°K
Colour rendering index: Ra85
Dimmer function: No
Weight: Kg 10

ANODINE FLOOR | ILL.ANOD.100

13 lighting elements
Lamp shades and base in matt gold finish - Polished brass stems



◀ Foglie realizzate
asimmetricamente a mano da
esperti artigiani.

Handcrafted asymmetrical
metal leaves.



Comet Floor

DESIGN | PAOLO CASTELLI



Finishes of the above picture



Fabric
Natural
Col. Ivory



Metal Finish
Matt Satin
Brass



Wood
Oiled
Canaletto
walnut

Alternative finishes



Wood
Metallized
acidetched
zinc

Lampada totemica realizzata con basamento in noce Canaletto oliato o in legno metallizzato con finitura zinco acidato, impreziosito da un inserto in ottone satinato opaco. Paralume a forma di anello realizzato in tessuto naturale col. avorio.

Totemic lamp made with base in oiled Canaletto walnut or in metallized wood with acidetched zinc finish, embellished with an insert in matt satin brass. Ring-shaped lampshade made of natural fabric col. ivory.

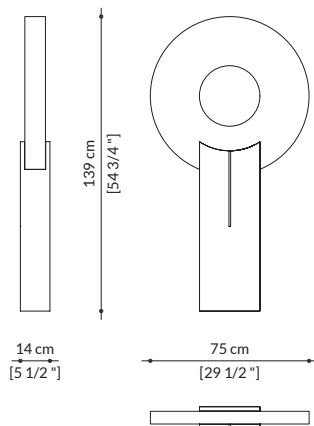

TECHNICAL SHEET

COMET FLOOR

Light source: LED
Total power: 40W
Voltage: 100-240V
Rated luminous flux: 1050 lm/mt
Colour temperature: 3000°K
Colour rendering index: Ra>90
Dimmer function: Si
Weight: 10 Kg

FLOOR LAMP | ILL.COME.100

Base in oiled Canaletto walnut. Lampshade in natural fabric Col. Ivory

FLOOR LAMP | ILL.COME.101

Base in metallized wood with acidetched zinc finish. Lampshade in natural fabric Col. Ivory



Icone Luminose Floor

DESIGN | PAOLO CASTELLI



01 02 03 04

Finishes of the above picture



Metal Finish
Matt Gold



Murano
Glass
Col. Blue
Grey



Murano
Glass
Col. Petrol
Green



Murano
glass
Col. Medium
Amber



Murano
glass
Col. Brown
Fumè



Murano
Glass
Col.
Amethyst

Lampade da terra dal carattere totemico, oggetti unici realizzati artigianalmente grazie alla tradizionale tecnica del vetro soffiato di Murano. Icone Luminose si compone di quattro modelli in grado di risplendere di una luce propria, ognuno definito da una struttura in metallo finitura oro opaco, vestita da una combinazione di quattro elementi di vetro posti uno sopra l'altro e distinti da diverse geometrie e colori. Una proposta vivace, intensa e luminosa, in grado di portare un'inaspettata energia cromatica negli ambienti indoor.

Totem-like floor lamps, uniquely crafted using the traditional Murano blown glass technique. Icone Luminose comprise four models capable of radiating their own light, each defined by a metal structure with a matte gold finish, adorned by a combination of four glass elements stacked one above the other, distinguished by various geometries and colours. A lively, intense, and luminous proposition, capable of bringing an unexpected chromatic energy to indoor spaces.

01

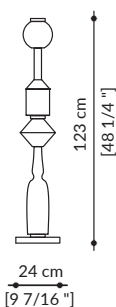

02

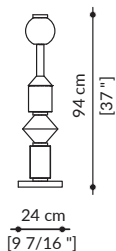

03

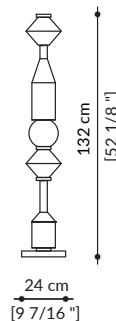

04

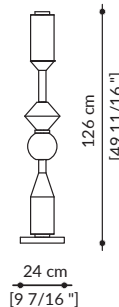

TECHNICAL SHEET

LAMP 01 AND 04
Light Source: 3 x 250mA 2,5W
Total Power: 6,5W
Colour temperature: 3000°K
Power supply: 230V 50/60 Hz
Luminous flux: 1000 lm
Dimmer function: No
Apparatus in CL1

TECHNICAL SHEET

LAMP 02 AND 03
Light Source: 4 x 250mA 2,5W
Total Power: 8W
Colour temperature: 3000°K
Power supply: 230V 50/60 Hz
Luminous flux: 1000 lm
Dimmer function: No
Apparatus in CL1

LAMP 01 | ILL.MORA.001

Structure in metal in matt gold finish
Handmade Murano glass. Colour: Petrol Green, Amethyst, Brown Fumè, Medium Amber

LAMP 02 | ILL.MORA.002

Structure in metal in matt gold finish
Handmade Murano glass. Colour: Amethyst, Brown Fumè, Medium Amber

LAMP 03 | ILL.MORA.003

Structure in metal in matt gold finish
Handmade Murano glass. Colour: Amethyst, Brown Fumè, Medium Amber

LAMP 04 | ILL.MORA.004

Structure in metal in matt gold finish
Handmade Murano glass. Colour: Amethyst, Brown Fumè, Medium Amber, Blue grey



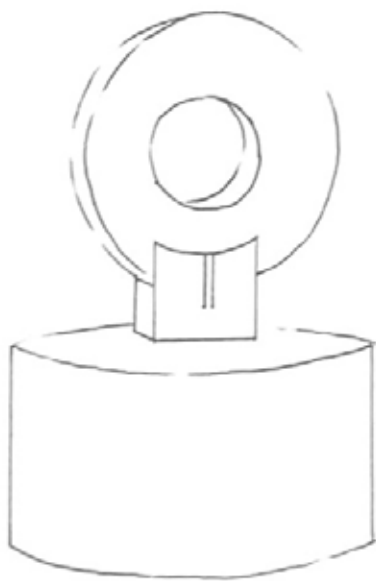



Lampade da Tavolo
Table Lamp

Fanus Table

DESIGN | PAOLO CASTELLI



Finishes of the above picture

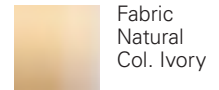

Alternative lampshade

Una lampada da tavolo compatta e portatile pensata per illuminare lo spazio e regalare l'intimità dell'ombra. La famiglia Fanus reinterpreta il concetto di lanterna, distinguendosi per i dettagli in cuoietto naturale che impreziosiscono l'intera figura. Fanus è disponibile anche in versione a sospensione e da tavolo. Lampada da tavolo con dettagli in cuoietto naturale a batteria e interruttore touch. Il corpo illuminante è in vetro cannettato trasparente con sorgente luminosa LED. Il paralume è disponibile in due versioni: in tessuto o in vetro di Murano curvato color ambra con parti metalliche verniciate di nero.

A compact and portable table lamp designed to illuminate the space and provide the intimacy of shadows. The Fanus family reinterprets the concept of a lantern, distinguished by natural cuoio leather details that embellish the entire design. Fanus is also available in pendant and table lamp versions. Battery-operated table lamp with natural cuoio leather details and touch switch. The lighting element is made of transparent ribbed glass and has a LED light source. The lampshade is available in two versions: fabric or curved Murano glass in amber color with black painted metal parts.

TECHNICAL SHEET

FANUS TABLE

Light source: CC LED

Total power: 2,1W

Voltage: Battery 3,7 V-2600mAh

Rated luminous flux: 300 lm

Colour temperature: 3000°K

Colour rendering index: 84

Dimmer function: Dimmable touch

Weight with glass: 7 Kg

Weight with lampshade: 5 Kg

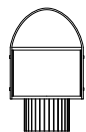

44
17 5/16"

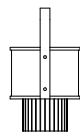

27
10 1/2"



FANUS TABLE LAMP GLASS | ILL.FANU.410

Structure in black metal with brass details, blown ribbed glass, lampshade in glass Col. Amber

FANUS TABLE LAMP FABRIC | ILL.FANU.411

Structure in black metal with brass details, blown ribbed glass, lampshade in fabric Col. Ivory



◀ Dettagli in cuoietto naturale. Paralume disponibile in tessuto o in vetro di Murano curvato color ambra con parti metalliche verniciate di nero.

Natural cuoio leather details. Lampshade available in fabric or amber curved Murano glass with painted black metal parts.



Manta Table

DESIGN | VITTORIO PARADISO



Finishes of the above picture



Murano Glass
Col. Fumè
Hand-forged



Natural
Brass



Murano Glass
Col. Amber
Hand-forged

Alternative finish

Piegare la materia all'arte, una lampada da tavolo che assume le sembianze di una foglia che volteggia leggera nell'ambiente. La famiglia di lampade Manta accoglie le versioni da terra e da tavolo, ampliando la proposta di sistemi di illuminazione caratterizzati da un'eterea leggerezza e sobria eleganza. La sorgente di luce a LED, una raffinata foglia in vetro color fumè o ambra, forgiata a mano dai maestri vetrai di Murano, illumina l'ambiente con grande calore e naturalezza, dando vita ad un'atmosfera avvolgente e di assoluta armonia.

Bending matter to art, a table lamp that takes on the appearance of a leaf that twirls lightly in the room. The Manta family of lamps welcomes floor and table versions, expanding the range of lighting systems characterised by ethereal lightness and understated elegance. The LED light source, a refined fumè or amber coloured glass leaf, hand-forged by master glassmakers in Murano, illuminates the room with great warmth and naturalness, creating an enveloping atmosphere of absolute harmony.

TECHNICAL SHEET

MANTA TABLE

Light source: LED

Total power: 10W

Voltage: 220-240V

Rated Luminous Flux: 800 lm

Colour temperature: 3000°K

Color Rendering Index: Standard CRI>80

Dimmer function: No

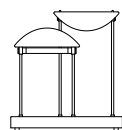

43
16 15/16"

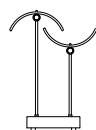

40
15 3/4"

31
12 1/4"

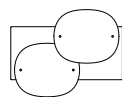

19
7 5/16"

MANTA FLOOR LAMP AMBRA | ILL.MANT.400

Ambra colored glass leave, hand-forged in Murano, encapsulated in a cylindrical satin brass structure which contains the LED light source

MANTA FLOOR LAMP FUMÈ | ILL.MANT.401

FUMÈ colored glass leave, hand-forged in Murano, encapsulated in a cylindrical satin brass structure which contains the LED light source



My Lamp Table

DESIGN | PAOLO CASTELLI



Finishes of the above picture



Metal Finish
Matt Gold

Alternative finishes



Metal Finish
Matt Black
Nickel

My Lamp Table è una graziosa ed elegante lampada da tavolo, ideale per studi, salotti e zona notte, composta da una struttura metallica trattata in finitura oro opaco che regge un piccolo "bouquet" di tubi realizzati in vetro borosilicato veneziano.

My Lamp Table is a visually pleasing and elegant table lamp, ideal for studios, lounges and bedrooms. It comprises a metal structure with a matt gold finish that supports a "bouquet" of tubes made of venetian borosilicate glass.

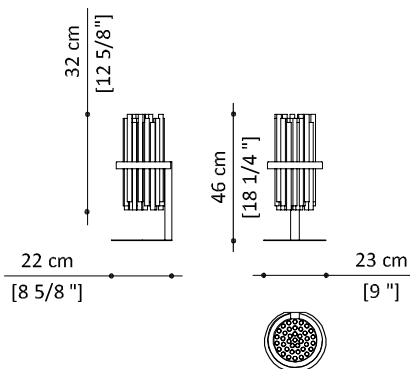

TECHNICAL SHEET
MY LAMP TABLE
Light source: Strip LED
Total power: 13W
Voltage: 240V
Rated luminous flux: 860 lm
Colour temperature: 2700°K
Colour rendering index: Ra80
Dimmer function: No
Weight: Kg 4

MY LAMP TABLE | ILL.MYLA.400

Matt gold finish metal band and transparent borosilicate glasses

MY LAMP TABLE BLACK NICKEL | ILL.MYLA.400.BN

Matt black nickel finish metal band and transparent borosilicate glasses



Comet Table

DESIGN | PAOLO CASTELLI



Finishes of the above picture



Fabric
Natural
Col. Ivory



Metal Finish
Matt Satin
Brass



Wood
Oiled
Canaletto
walnut



Wood
Metallized
acidetched
zinc

Alternative finishes

Lampada totemica realizzata con basamento in noce Canaletto oliato o in legno metallizzato con finitura zinco acidato, impreziosito da un inserto in ottone satinato opaco. Paralume a forma di anello realizzato in tessuto naturale col. avorio.

Totemic lamp made with base in oiled Canaletto walnut or in metallized wood with acidetched zinc finish, embellished with an insert in matt satin brass. Ring-shaped lampshade made of natural fabric col. ivory.

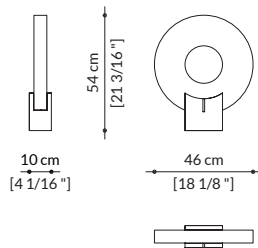

TECHNICAL SHEET

COMET TABLE

Light source: LED

Total power: 24W

Voltage: 240V

Rated luminous flux: 1050 lm/mt

Colour temperature: 3000°K

Colour rendering index: Standard Ra>90

Dimmer function: Si

Weight: Kg 5

TABLE LAMP | ILL.COME.400

Base in oiled Canaletto walnut. Lampshade in natural fabric Col. Ivory

TABLE LAMP | ILL.COME.401

Base in metallized wood with acidetched zinc finish. Lampshade in natural fabric Col. Ivory



Anodine Table

DESIGN | PAOLO CASTELLI

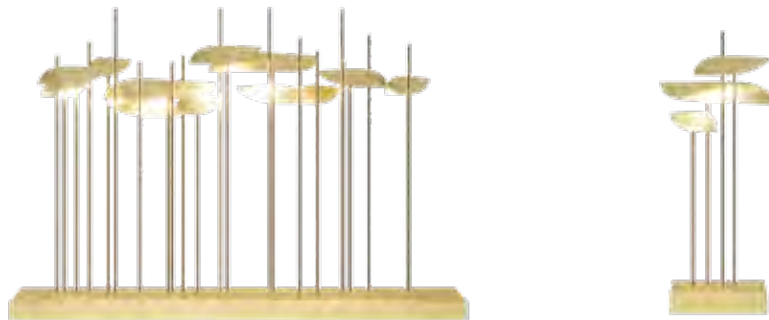

Finishes of the above picture



Metal Finish
Matt Gold



Polished
brass

Anodine Table è una graziosa lampada da tavolo. La preziosità della lavorazione artigianale rende ogni pezzo della collezione unico nel suo genere. È composta da 26 steli in ottone lucido ancorati ad una base metallica con finitura oro opaco satinato verniciata artigianalmente, che vengono decorati da foglie in metallo, realizzate asimmetricamente a mano da esperti artigiani e finite con finitura oro satinato. Disponibile anche in versione Mini, composta da 3 steli in ottone lucido ancorati ad una base metallica con finitura oro opaco satinato che vengono decorati da foglie in metallo realizzate asimmetricamente a mano da esperti artigiani.

Anodine Table is a pretty table lamp. The preciousness of the craftsmanship makes each piece of the collection unique. It consists of 26 polished brass stems anchored to a metal base with a satin matt gold finish painted by hand, which are decorated with metal leaves, made asymmetrically by hand by expert craftsmen and finished with satin gold finish. Also available in the Mini version, consisting of 3 polished brass stems anchored to a metal base with a satin matt gold finish that are decorated with metal leaves made asymmetrically by hand by expert craftsmen.

TECHNICAL SHEET ANODINE TABLE

Light source: Power LED COB
Total power: 13 x 3,15W (41 W)
Voltage: 110-295V
Rated luminous flux: 5135 lm
Colour temperature: 3000°K
Colour rendering index: Ra85
Dimmer function: No
Weight: Kg 10

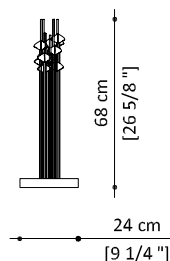
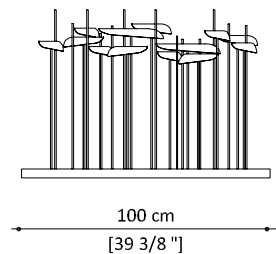

ANODINE TABLE | ILL.ANOD.410

13 lighting elements
Lamp shades and base in matt gold finish - Polished brass stems

MINI

TECHNICAL SHEET ANODINE MINI

Light source: Power LED COB
Total power: 10,5W
Voltage: 120V
Rated luminous flux: 1185 lm
Colour temperature: 3000°K
Colour rendering index: Ra85
Dimmer function: No
Weight: Kg 3

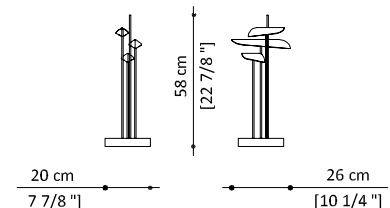

ANODINE MINI | ILL.ANOD.430

3 lighting elements
Lamp shades and base in matt gold finish - Polished brass stems



Colette & Hugo Table

DESIGN | PAOLO CASTELLI



Finishes of the above picture



Fabric
Percalle



Murano Glass with
24KT golden leaf
powder

Dalla maestria degli artigiani vetrai di Murano nasce questa amabile coppia di lampade da tavolo. Ne viene proposto un ensemble per enfatizzare la perfetta armonia di forma e stile, amabili tuttavia anche singolarmente per conferire un tocco sofisticato a qualsiasi tipo di ambientazione. La base è a forma di goccia, realizzata in vetro di Murano con all'interno polvere d'oro 24KT in sospensione, e paralume in tessuto percale realizzato artigianalmente, Hugo, più compatta, ha una forma piena e morbida ed un cappello cilindrico, mentre Colette è slanciata e leggermente più alta, con un paralume rastremato.

Thanks to the Murano glass hand craftsmanship virtuosity, a lovely couple of table lamps has appeared. This ensemble emphasizes the perfect shape and style harmony that can be appreciated also in their singularity in order to give a sophisticated touch to every kind of set. The drop-shape base is made of Murano glass enclosing a 24KT golden leaf, the lampshade is in a hand made percale fabric. Hugo, more compact, has a full and soft shape and a cylindrical lampshade; otherwise, Colette is slim and a bit higher with a tapered lampshade.

COLETTE

TECHNICAL SHEET COLETTE

Light source: E27 light bulb
Lamp socket: E27
Total power: 8W
Voltage: 230V
Rated luminous flux: 1055 lm
Colour temperature: 2700°K
Colour rendering index: Ra>80
Dimmer function: No
Weight: Kg 8

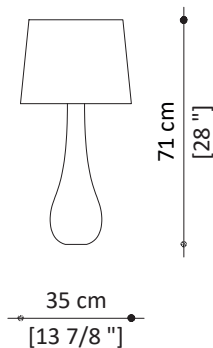

HUGO

TECHNICAL SHEET HUGO

Light source: E27 light bulb
Lamp socket: E27
Total power: 8W
Voltage: 230V
Rated luminous flux: 1055 lm
Colour temperature: 2700°K
Colour rendering index: Ra>80
Dimmer function: No
Weight: Kg 8

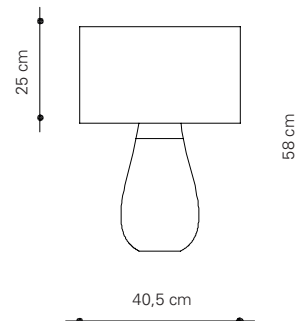

COLETTE | ILL.ALLU.410

Murano glass with 24KT golden leaf powder. Percalle fabric lampshade

HUGO | ILL.ALLU.420

Murano glass with 24KT golden leaf powder. Percalle fabric lampshade



Ambra Table

DESIGN | ILARIA BALDUINO SARTORI



Finishes of the above picture



Metal Finish
Matt Bronzed
Brass



Fabric
Blended
viscose



Plexyglass
lucite

Ambra è l' abat-jour ideale per creare dei caldi ed eleganti punti luce in salotti, camere padronali e raffinate suite. Questa lampada è composta da un'asta in ottone con finitura bronzo ottone opaco nella quale sono inseriti e ruotano dischi in lucite alternati a metallo che creano un sofisticato gioco di trasparenze e riflessi di luci. Ambra è completata nella parte superiore da un prezioso cappello in tessuto misto viscosa col. crema, impreziosito ai bordi da un'elegante passamaneria in tinta.

Ambra is the ideal table lamp to create warm and elegant lighting points in lounges, master bedrooms and elegant suites. It comprises a brass rod with a matt bronzed brass finish on which lucite rotating discs alternate with metal ones, creating a sophisticated transparency and light reflection. Ambra is finished with an exquisite lampshade in viscose blended fabric col. cream, enriched at the edges with precious matching braid.

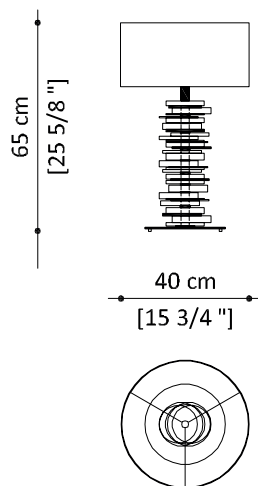

TECHNICAL SHEET

AMBRA

Light source: E27 light bulb

Lamp socket: 1 x E27

Total power: 9W

Voltage: 230V

Rated luminous flux: 1055 lm

Colour temperature: 2700°K

Colour rendering index: Ra>80

Dimmer function: No

Weight: Kg 16

AMBRA TABLE LAMP | ILL.AMBR.410

Metal and plexyglass with blended viscose fabric lampshade



◀ Lucite: materiale molto diffuso nella realizzazione di gioielli e bijoux negli anni '30 e '40.

Lucite: widespread material used for jewellery and bijoux in the '30s and '40s.



Nettuno Table

DESIGN | VITTORIO PARADISO



Finishes of the above picture



Metal Finish
Matt Gold



Murano
Glass
Col. Pink



Murano
Glass
Col. Straw



Fabric
Percale

Coppia di lampade da tavolo che completa la collezione Nettuno (tavolo, desk e coffee table). Il corpo in vetro scanalato a mano ha forma di parallelepipedo e viene presentato di colore e altezze diverse. Il corpo più slanciato è di colore rosa antico, mentre quello più compatto è di color pagliesco, entrambi reggono un portalampada con due lampadine E27. Il paralume in tessuto percale color avorio, l'accensione a catenella e il cavo di alimentazione in tessuto color oro contribuiscono a creare una silhouette calda e sofisticata. È disponibile in due dimensioni.

Pair of table lamps that complete the Nettuno collection (table, desk and coffee table). The body in hand-grooved glass in the shape of a parallelepiped is presented in different colours and heights. The more slender body is in antique pink, while the more compact body is straw-coloured; both are fitted with a lamp holder for two E27 bulbs. The ivory-coloured percale fabric lampshade, the chain-style pull-cord and the gold-coloured fabric power supply cable contribute to creating a warm and sophisticated silhouette. It is available in two sizes.

SMALL

TECHNICAL SHEET
NETTUNO TABLE LAMP SMALL
Light source: E27 LED 2X
Total power: 5.5W x 2
Voltage: 220-240V
Rated luminous flux: 470 lm
Colour temperature: 2700°K
Colour rendering index: Ra>80
Dimmer function: No
Weight: Kg 6

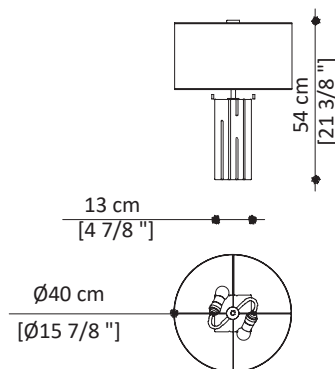

SMALL | ILL.NETT.420
Structure in hand-grooved glass Col. Straw. Lampshade in Percale fabric

BIG

TECHNICAL SHEET
NETTUNO TABLE LAMP BIG
Light source: E27 LED 2X
Total power: 5.5W x 2
Voltage: 220-240V
Rated luminous flux: 470 lm
Colour temperature: 2700°K
Colour rendering index: Ra>80
Dimmer function: No
Weight: Kg 6

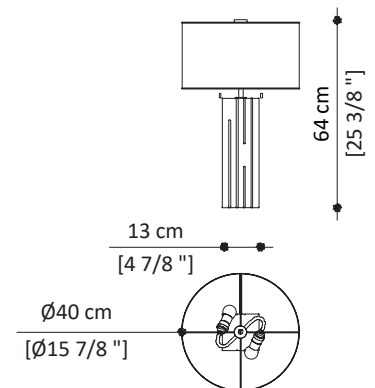

BIG | ILL.NETT.410
Structure in hand-grooved glass Col. Pink. Lampshade in Percale fabric



◀ Corpo parallelepipedo in vetro di Murano lavorato e scanalato a mano.

A glass parallelepiped fluted by hand by Murano artisans.



Oscar Table

DESIGN | PAOLO CASTELLI, THIERRY LEMAIRE & HUBERT DE MALHERBE



Finishes of the above picture



Faenza
Ceramic
Raw finish
Col. Optical
White



Fabric Hemp fiber
Col. Beige
100% organic

Lampada con base realizzata in ceramica artigianale di Faenza color bianco opaco. Il paralume 100% naturale è realizzato in fibra di canapa nepalese. Sorgente luminosa E27.

Lamp with base made of white matt handmade Faenza ceramic. The 100% natural lampshade is made of Nepalese hemp fibre. Lighting source E27 bulb.

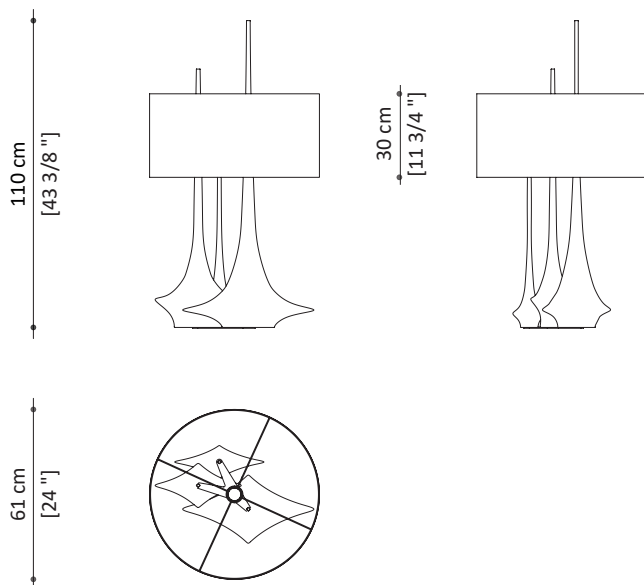

TECHNICAL SHEET
OSCAR LAMP
Light source: E27 bulb
Total power: 8W
Voltage: 220-240V
Rated luminous flux: 1055 lm
Colour temperature: 2700°K
Colour rendering index: Ra>80
Dimmer function: No
Weight: 6 Kg

OSCAR LAMP | ILL.OSCA.100
Base in Faenza ceramic. Lampshade in Nepalese hemp fibre



Kaala Table

DESIGN | PAOLO CASTELLI, THIERRY LEMAIRE & HUBERT DE MALHERBE



Finishes of the above picture



Vietri Ceramic
Glossy finish
Col. Optical
White



Metal Finish
Champagne
Matt



Fabric Hemp
fiber
Col. Beige
100% organic

Alternative base option



Vietri Ceramic
Glossy finish
Col. Yellow



Fabric Hemp fiber
Col. Turquoise
100% organic

Lampada con base in metallo color champagne opaco, ricoperto da lastre realizzate in ceramica artigianale di Vietri smaltata bianca o gialla. L'accostamento dei due materiali crea un elegante inserto metallico. Il paralume 100% naturale è realizzato in fibra di canapa nepalese color turchese o beige. Sorgente luminosa E27.

A lamp made of matt champagne-coloured metal structure, covered by handmade white or yellow-glazed Vietri ceramic. The combination of two materials creates an elegant metal trim. The 100% natural lampshade is made of Nepalese, turquoise or beige, hemp fibre. Lighting source E27 bulb.

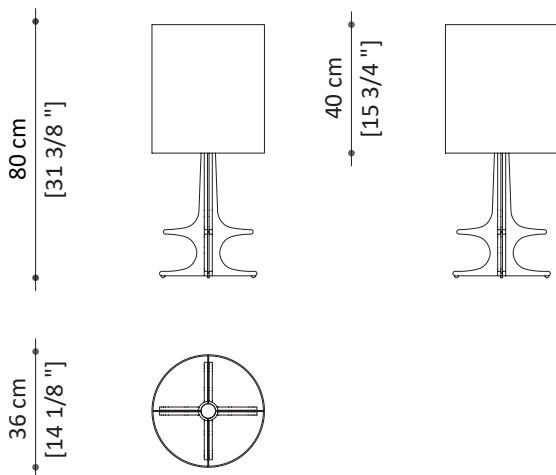

TECHNICAL SHEET

KAALA LAMP

Light source: E27 bulb
Total power: 8,5W
Voltage: 220-240V
Rated luminous flux: 1055 lm
Colour temperature: 2700°K
Colour rendering index: Ra>80
Dimmer function: No
Weight: 6,5 Kg

KAALA LAMP | ILL.KAAL.100

Base in Vietri ceramic Col. yellow or white. Lampshade in Nepalese hemp fibre



Icone Luminose Table

DESIGN | PAOLO CASTELLI



MOD 01



MOD 02

Finishes of the above picture



Fabric
Percalé



Murano
Glass
Col. Medium
Amber



Murano
Glass
Col. Brown
Fumè

La serie di lampade della collezione Morandi si arricchisce di modelli in due versioni da tavolo, oggetti che illuminano l'ambiente con una delicata presenza. Il corpo è composto da un vaso a forma di bottiglia realizzato in vetro soffiato da maestri vetrai di Murano, disponibile in due diverse dimensioni e colori, Fumé e Ambra. Il paralume dalla forma rastremata è realizzato in tela naturale, meticolosamente cucita a mano.

The Morandi collection's series of lamps is enriched with two models in table version, objects that illuminate the environment with a delicate presence. The body consists of a bottle-shaped vase crafted from blown glass by Murano glassmasters, available in two different sizes and colours, Fumé and Ambra. The tapered lampshade is made of natural canvas, meticulously hand-sewn.

MOD 01

TECHNICAL SHEET

ICONE LUMINOSE TABLE LAMP

Light source: E27 light bulb

Lamp socket: E27

Total power: 8W

Voltage: 230V

Rated luminous flux: 1055 lm

Colour temperature: 2700°K

Colour rendering index: Ra>80

Dimmer function: No

Weight: Kg 8

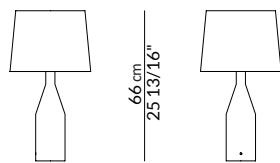

35 cm
13 13/16"

66 cm
25 13/16"

13 cm
4 15/16"



LAMP AMBER | ILL.MORA.410

Table lamp in blown Murano glass Col. Medium Amber

MOD 02

TECHNICAL SHEET

ICONE LUMINOSE TABLE LAMP

Light source: E27 light bulb

Lamp socket: E27

Total power: 8W

Voltage: 230V

Rated luminous flux: 1055 lm

Colour temperature: 2700°K

Colour rendering index: Ra>80

Dimmer function: No

Weight: Kg 8

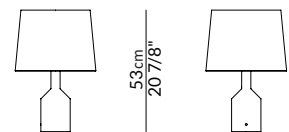

35 cm
13 13/16"

53 cm
20 7/8"

13 cm
5"



LAMP FUMÈ | ILL.MORA.420

Table lamp in blown Murano glass Col. Brown Fumè



STANDARD SALES TERMS AND CONDITIONS

General Provisions

A) The Standard Sales Terms and Conditions (hereinafter referred to as the "Standard Terms and Conditions") form an integral part of the agreements entered into between Paolo Castelli S.p.A. (hereinafter referred to as "Paolo Castelli") and the Purchaser for the supply of products supplied and/or distributed by the above mentioned company (hereinafter the "Products").

B) The Standard Terms and Conditions apply to all transactions entered into between Paolo Castelli and the Purchaser whether or not expressly referenced therein. Any terms or conditions different from those provided herein shall only take effect if confirmed in writing by Paolo Castelli. Paolo Castelli reserves the right to modify, supplement or amend the Standard Terms and Conditions, by attaching such changes to quotations or any written correspondence.

Quotations and orders

Customer's acceptance of the quotations submitted by Paolo Castelli - upon receipt of 50% deposit - is binding on the Customer and irrevocable. Upon receipt of such acceptance, Paolo Castelli will send the Customer an order confirmation expressly stating delivery method and the technical information necessary to deliver the goods (e.g. delivery addresses, delivery to the floor, time, contact persons and telephone number). Any quotations submitted by agents shall only be deemed to be valid and effective after they are confirmed in writing by Paolo Castelli. Any changes to or requests and integrations to quotations by agents or Customers shall be made in writing, and shall require a written confirmation by Paolo Castelli. Paolo Castelli disclaims any and all liabilities for possible errors or misunderstandings arising in connection with changes to orders placed verbally or over the telephone.

Prices and Payment Terms

Product Prices do not include VAT, which must be paid according to specific indications provided in the invoice. Taxes, duties, shipping, insurance, installation and after-sales service are not included in the prices, unless quoted separately. In addition to the other remedies allowed by applicable law or these General Terms and Conditions, Paolo Castelli reserves the right to charge late payment interests at the official interest rate set by the European Central Bank plus seven (7) points as of the day payment was due. Payments shall be made as follows: 50% down payment when quotation is signed; 50% balance shall be paid before Products are shipped. Any other conditions agreed upon shall require the written form. In the event of default or late payment after the term indicated by Paolo Castelli, even in part or limited to one price instalment, Paolo Castelli shall be entitled to terminate the agreement without further notice. All amounts paid up to that time shall be withheld by way of damage compensation.

Changes to orders

Any requests of changes deviating from the content of order confirmation may only be accepted if compatible with the production process and/or the process under way. If accepted, they may give rise to extra charges incurred in making such changes.

Orders - Customer's default

It is hereby expressly agreed that the Customer may not unilaterally terminate the order and/or the agreement. In the event after confirming an order Paolo Castelli becomes aware of detrimental events affecting the Purchaser such as protests, seizures, attachment, or it becomes known that the Purchaser is in financial difficulties, Paolo Castelli may, at its discretion, suspend order fulfilment and demand special guarantees, or terminate the agreement on grounds of Purchaser default under art. 1456 of the Italian Civil Code by written notice via registered mail with advice of receipt, fax or CEM.

Combinations of fabrics

If the requested covering is to be made with coordinated fabrics of different categories, the price applied will be that of the higher category.

Delivery and Delivery Terms

Unless otherwise agreed, delivery is ex works at Customer's risk. Notwithstanding the above, Paolo Castelli may charge an additional shipping fee to Customer on invoice. Partial deliveries are only allowed when agreed upon between the parties and any extra costs shall be borne by Customer. The delivery times indicated by Paolo Castelli are not binding and are computed in working days starting from receipt of the first down payment. In the event delivery is postponed through fault of the Customer and the Product needs to be kept in stock for more than 5 days after the agreed delivery date, any relating costs shall be charged to Customer and Paolo Castelli shall not be liable for any damage to and/or deterioration of the Product. Unless otherwise agreed, downloading and delivery to floor are at the Customer's expense. For any events outside the control of Paolo Castelli, such as orders of authorities, shortage of raw materials, riots of any kind and other force majeure events, Paolo Castelli shall deem itself to not be bound to any terms or commitments for the duration of the adverse event.

Installation

At Customer's request, installation may be performed by personnel appointed by Paolo Castelli, and any costs incurred for installers and the assistance of skilled personnel shall be at Customer's charge. Installation does not include any masonry work, plant installation, or any other work not expressly specified on order or anyway outside the scope of the supply. Customer shall make available a suitable storage room for products and equipment. Paolo Castelli shall not be liable for faults or breakdown occurring during installation.

Responsibility

Paolo Castelli does not respond to any damage to person or property caused by the incorrect installation of its lighting fixtures and furniture.

Warranty

It is the Customer's responsibility to check product compliance at the time of receipt and anyway before commissioning. Unless Customer claims a defect and informs the seller within eight days from discovering such defect, Customer's rights under applicable law shall become null and void. Failure to comply with payment terms and conditions on the part of the Purchaser shall make the warranty null and void.

Retention of title

Pursuant to articles 1523 and 1524 of the Italian Civil Code, the parties agree that the sales transaction is subject to retention of title in favour of the seller. The parties agree that the ownership of the Product is transferred to the Customer at the time the full price is settled, whereas possession and the associated risk to the Purchaser is transferred at the time the product is shipped to Customer.

Court of jurisdiction

The agreement is governed by Italian law. Any dispute concerning the construction or performance of agreements between the parties shall be submitted to the Court of Bologna, that shall have sole jurisdiction.

I prodotti Paolo Castelli privilegiano materiali biologici e sono frutto di una particolare ricerca nel campo dell'ecosostenibilità.

A giugno 2019 Paolo Castelli S.p.A. ha ottenuto la certificazione FSC® Forest Stewardship Council®. La scelta di certificarsi è stata un impulso dato dal mercato, certo, ma anche la naturale prosecuzione di un percorso già avviato dall'Azienda, che concepisce la filiera del legno come un circolo virtuoso. L'azienda definisce così il proprio percorso: l'idea di confermarsi autrice di prodotti di assoluta qualità si unisce ad un impegno, rigoroso e responsabile, nei confronti dell'ambiente, che i legni utilizzati provengono da tagli legali e filiere certificate, per dimostrare il proprio impegno per il raggiungimento dell'obiettivo globale di guidare il mercato verso una gestione responsabile del patrimonio forestale.

For our products we prefer organic materials and they are the result of particular research in the environmental sustainability field.

In June 2019 Paolo Castelli S.p.A. has obtained the FSC® Forest Stewardship Council® certification. The decision to certify itself was an impulse given by the market, certainly, but also the natural continuation of a path already started by the Company, which conceives the wood supply chain as a virtuous circle. The company thus defines its own route: the idea of confirming itself as the author of products of absolute quality is combined with a commitment, rigorous and responsible, towards the environment, guaranteeing that the woods used come from legal cuts and certified supply chains, to demonstrate its commitment to achieving the global objective of guiding the market towards a responsible management of forest heritage.



CERTIFICATIONS:
ISO 9001, ISO 14001, FSC

La descrizione e le immagini dei prodotti del presente catalogo sono puramente indicative e non possono essere considerate vincolanti ai fini del loro utilizzo. Paolo Castelli S.p.A. si riserva di apportare ai prodotti le modifiche che ritiene più opportune, in qualsiasi momento e senza preavviso. I prodotti, di natura artigianale, possono presentare artefatti materici o irregolarità di lavorazione. Tali irregolarità sono da considerarsi parte integrante della struttura del prodotto stesso e garanzia della lavorazione interamente artigianale. Per ulteriori informazioni sulle caratteristiche tecniche dei prodotti, invitiamo a consultare il sito www.paolocastelli.com dove troverete l'elenco dei contatti a cui rivolgervi.

Descriptions and pictures of the products included in the present catalogue are purely indicative and cannot be considered binding for their final use. Paolo Castelli S.p.A. reserves itself the right to modify its own products without any prior notification. The handmade artisan production can present irregularities due to the manufacturing. These irregularities must be considered essential part of the product itself and guarantee of entirely handcrafted manufacturing. For any further technical information on the products, please visit www.paolocastelli.com where you can find all the contacts you can address to.

DOCUMENT DATED: MARCH 2024

BOLOGNA
Headquarter

MILAN
Showroom

PARIS
Showroom

HEADQUARTER VIA I° MAGGIO, 93 | 40064 OZZANO DELL'EMILIA | BOLOGNA - ITALY
TEL. +39 051 4695511 | info@paolocastellipa.com | www.paolocastelli.com