

The 2024 Imagine Collection

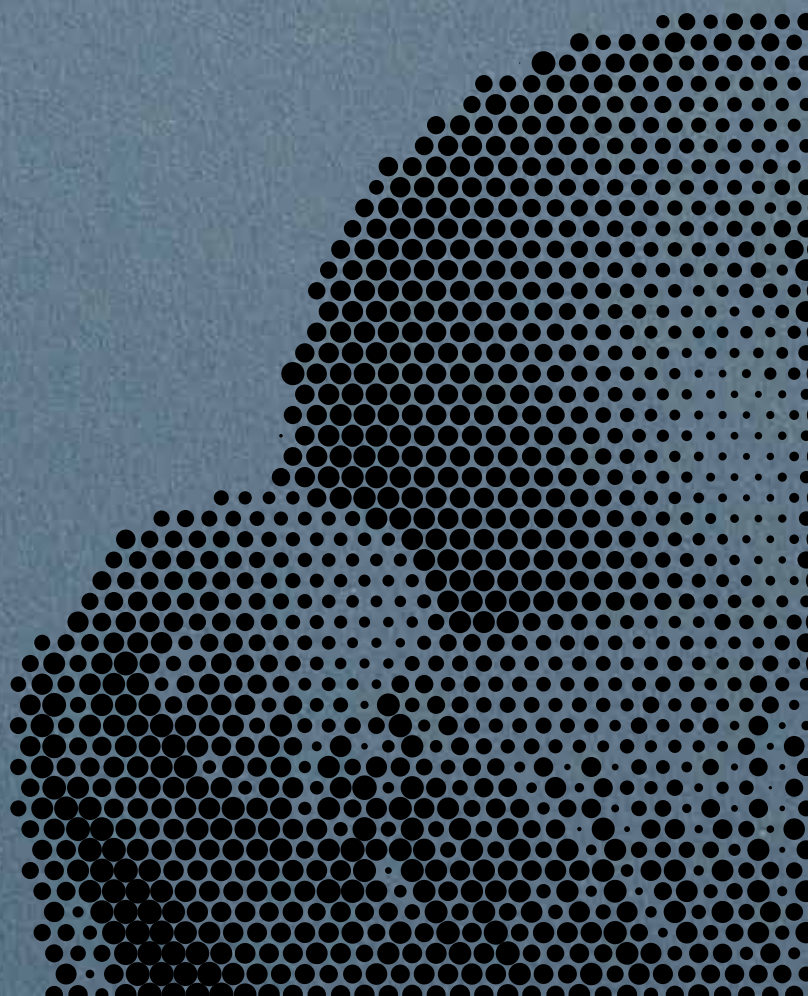

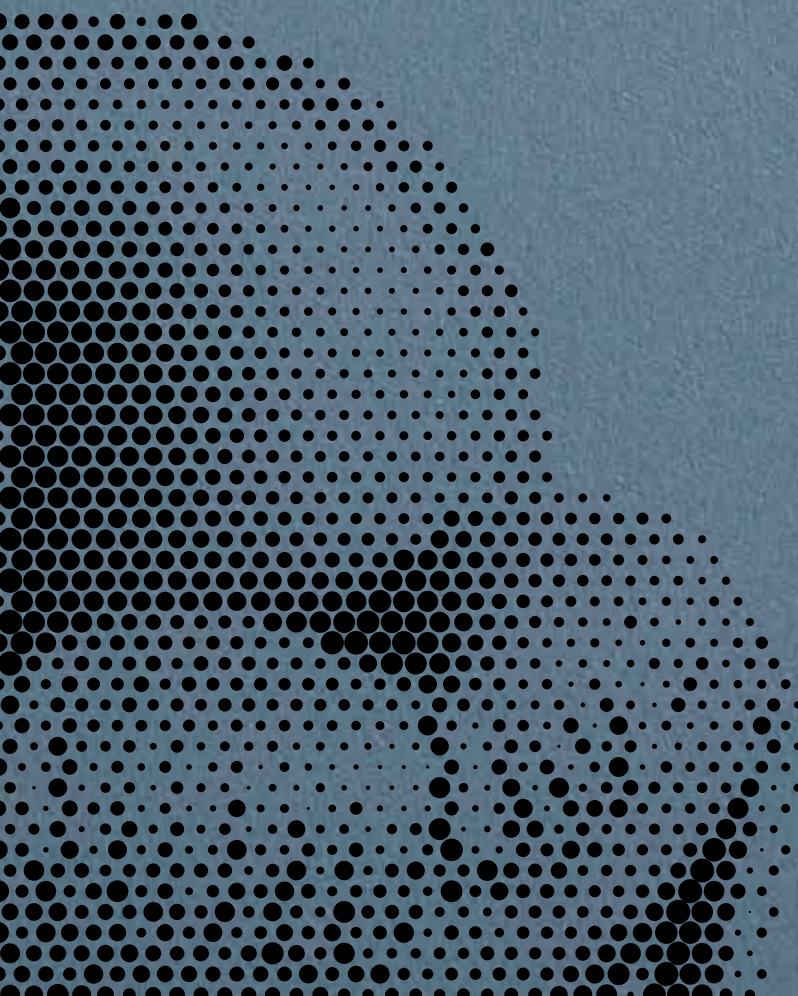

2024
Imagine Collection
Main Index

6	The 2024 Imagine Collection		
88	Indoor Living	164	Beautilities
	Armchairs and Sofas		Accessories
88	Bretagne Gran Comfort	164	Nymph
92	Happy Jack	168	Office Collection
102	Martha Ozwald Boateng x Poltrona Frau	178	Pet Collection
106	Parka	116	Squash Rug
110	Squash	120	Squash Mirror
126	Vanity Fair XC Imagine Edition	188	Tableau
	Chairs, Small Armchairs and Stools	190	Tableware Collection
130	Archibald Dining chair Large	198	Water Illusion
134	Duo Chair		
138	Ginger Ozwald Boateng x Poltrona Frau		
142	Nice	202	Work-Lab
	Tables, Small tables and Desks	202	Archibald Task Chair
146	Peek-a-Book Large	210	Pillow Cinema
	Benches and Ottomans	220	2024 New Upholsteries
150	Brera 90th Anniversary Edition		
	Beds	225	Translations and Technical Drawings
154	Archibald Bed		
	Drawer and Complementary Night Units		
160	Stock'n Roll		

Indoor Living

Armchairs and Sofas



88 Bretagne Gran Comfort



92 Happy Jack



102 Martha (Oswald Boateng x Poltrona Frau)



106 Parka



110 Squash



126 Vanity Fair XC Imagine Edition

Chairs, Small Armchairs, Stools



130 Archibald Large Dining Chair



134 DUO Chair/Small armchair



138 Ginger Oswald Boateng x Poltrona Frau



142 Nice

Tables, Small tables and Desks



146 Peek-a-book Large

Beds



154 Archibald Bed

Large accessories, benches and ottomans

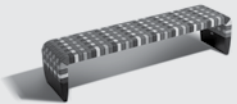

150 Brera 90th Anniversary Edition

Drawer and complementary night units



160 Stock'n Roll

Beautilities

Accessories



164 Nymph



168 Office Collection



178 Pet Collection

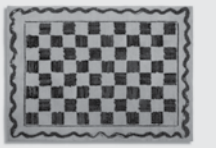

116 Squash Rug



120 Squash Mirror



188 Tableau N'est season



190 Tableware Collection



198 Water Illusion

Work-Lab



202 Archibald Task Chair



210 Pillow Cinema

2024 Poltrona Frau Imagine Collection

Imagination - a powerful tool to visualise our desires and shape our reality. The theme of the new Poltrona Frau collection is a profound inner contemplation on the vital role of creative freedom; an approach that enables us to appraise the past, to interpret the present, and to launch ourselves into the future.

How much space do we actually dedicate to the Imagination in our daily lives? Poltrona Frau invites us to contemplate this in its new Imagine collection, which will be presented in Milan on the occasion of the Salone del Mobile 2024.

In art, in literature and in music (John Lennon's profound lyrics immediately spring to mind), the Imagination has always played a vital and familiar role which, nevertheless, risks remaining constrained within the, albeit vast, confines of individual artistic expression. The Imagine Collection challenges this concept by enticing the Imagination to enter into, and to become part of, our daily lives. If you can imagine it, you can also achieve it... thus it becomes a tool for transforming our reality, based on our needs and desires.

The word 'Imagination' translates from the Greek word 'eikasias', meaning the ability to think outside of logical processes. This manner of thinking laterally has been part of Poltrona Frau's DNA since it was founded by Renzo Frau, renowned for his superior technical intellect and commercial intuition. And it has continued to evolve in ever-changing ways throughout the brand's history, in its catalogue and in the various lines of the collection which, this year, calls upon many new designers to collaborate on the various creative projects.



↖ Squash armchair and ottoman, Sage version - Pelle Frau®
ColorSphere® SC 176 Darsena / SC 173 Glauco
Squash small table, Sage version
(Pelle Frau® ColorSphere® SC 173 Glauco)



↑ Squash armchair and ottoman, Sage version - Pelle Frau®
ColorSphere® SC 176 Darsena / SC 173 Glauco
↗ Squash small table, Sage version
(Pelle Frau® ColorSphere® SC 173 Glauco)





↑ Squash armchair and ottoman, Sage version - Pelle Frau® ColorSphere® SC 176 Darsena / SC 173 Glauco
↙ Squash small table, Sage version (Pelle Frau® ColorSphere® SC 173 Glauco)



↖ Parka modular sofa, Fabric Haruka Whity / Pelle Frau® Nest Madreperla
Parka 3-seater sofa, Pelle Frau® Nest Pietra di Sole
Chado carpet, Pearl grey
Bob Ø45 h 52 small table, Pelle Frau® Nest Pietra di Sole
Pierre 150×60 small table, Marquinia marble with natural finish
Spakler large and medium lanterns





- ↖ ↑ Parka modular sofa, Fabric Haruka Whity / Pelle Frau® Nest Madreperla
- ↑ Parka 3-seater sofa, Pelle Frau® Nest Pietra di Sole
- Chado carpet, Pearl grey
- Pierre 150×60 small table, Marquinia marble with natural finish



↗ Parka 3-seater sofa, Pelle Frau® Nest Pietra di Sole
Chado carpet, Pearl grey
Bob 045 h 52 small table, Pelle Frau® Nest Pietra di Sole
Pierre 150×60 small table, Marquinia marble with natural finish
Spakler large and medium lanterns



↗ Nice chair, Pelle Frau® ColorSphere® SC 146 Coccio Pesto with natural ash legs; Mesa Due Dining table 180 cm, Calacatta marble top with moka ash Lazy Susan and leg in Rosso Bulgaro saddle leather

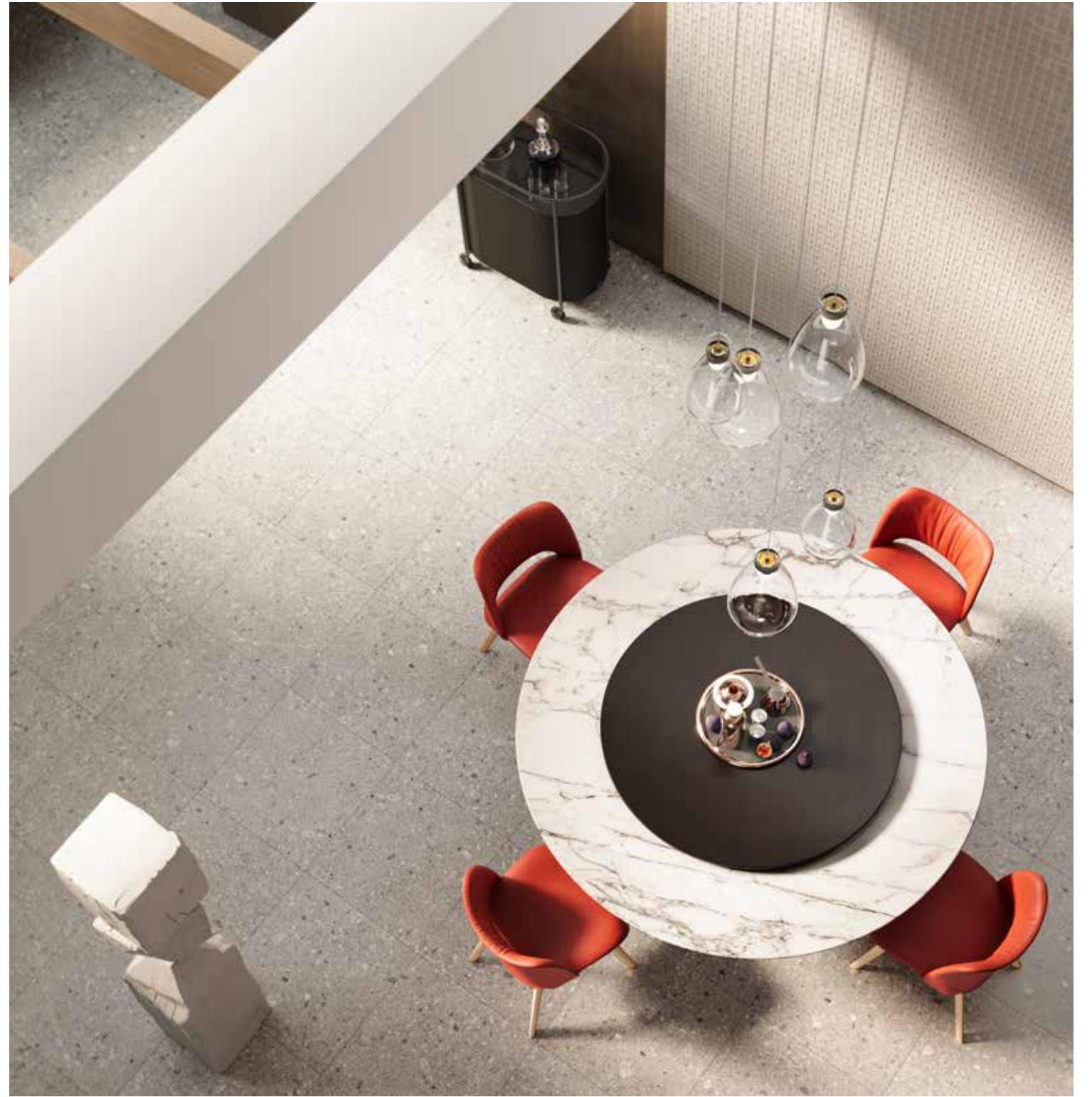





➤ Bretagne Gran Comfort, Pelle Frau® Motif Knits Grey Salt with cushions in Pelle Frau® Velvety Grey Salt Ilary small table, Calacatta marble top with natural ash base Dezza 24 armchair, Redeavance fabric



➤ Bretagne Gran Comfort, Pelle Frau® Motif Knits Grey Salt with cushions in Pelle Frau® Velvety Grey Salt





➤ Archibald Bed, Pelle Frau® ColorSphere® SC 92 Garnet
Stock'n Roll bedside table, Pelle Frau® ColorSphere® SC 92 Garnet
Nymph medium table lamp, Pelle Frau® ColorSphere® SC 68 Sahara /
smoked lampshade



↑ Archibald Bed, Pelle Frau® ColorSphere® SC 92 Garnet



↑ Squash Mirror, freestanding long version, Pelle Frau® ColorSphere® SC 92 Garnet
Brera bench, Pelle Frau® ColorSphere® SC 29 Ardesia



➤ Archibald Bed, Pelle Frau® ColorSphere® SC 92 Garnet
Stock'n Roll bedside table, Pelle Frau® ColorSphere® SC 92 Garnet
Nymph medium table lamp, Pelle Frau® ColorSphere® SC 68 Sahara /
smoked lampshade
Ming's Heart, Saddle Extra Carbone



↑ Squash Mirror, freestanding long version, Pelle Frau® ColorSphere® SC 92 Garnet
ColorSphere® SC 92 Garnet
Brera bench, Pelle Frau® ColorSphere® SC 29 Ardesia



↑ Archibald Bed, Pelle Frau® ColorSphere® SC 92 Garnet
Stock'n Roll bedside table, Pelle Frau® ColorSphere® SC 92 Garnet
Nymph medium table lamp, Pelle Frau® ColorSphere® SC 68 Sahara /
smoked lampshade







↑ Happy Jack sofa with recliner chaise longue, Saddle Cognac / Pelle Frau® Nest Arenaria



↑ Archibald armchairs, Pelle Frau® ColorSphere® SC 136 Ginger Bread



➤ Happy Jack sofa with recliner chaise longue, Saddle Cognac /
Pelle Frau® Nest Arenaria
Happy Jack 45° curved sofa, Saddle Cognac /
fabric Kalahari Greige color
Archibald armchair, Pelle Frau® ColorSphere®
SC 136 Ginger Bread



↖ **Infinite** table 340×120 cm, White Levigliani marble with Marquinia marble bases
Archibald Large Dining chair, Pelle Frau® ColorSphere® SC 66 India with titanium painted steel legs



➤ Archibald Large Dining chair, Pelle Frau® ColorSphere® SC 66 India with titanium painted steel legs



↖ **Infinite** table 340×120 cm, White Levigliani marble with Marquinia marble bases
Archibald Large Dining chair, Pelle Frau® ColorSphere® SC 66 India with titanium painted steel legs



➤ Squash armchair and ottoman, Blue version - Pelle Frau® ColorSphere® SC 276 Mineral Blue / SC 254 Steel Blue
Squash small table, Cream version (Pelle Frau® ColorSphere® SC 33 Travertino)
Squash Mirror, medium size, Pelle Frau® ColorSphere® SC 254 Steel Blue
Squash Rug, Blue color



➤ Squash armchair and ottoman, Blue version -
Pelle Frau® ColorSphere® SC 276 Mineral Blue / SC 254 Steel Blue
Squash small table, Cream version (Pelle Frau® ColorSphere®
SC 33 Travertino)
Squash Mirror, medium size, Pelle Frau® ColorSphere® SC 254
Steel Blue
Squash Rug, Blue color



↗ Peek-a-Book Large, Pelle Frau® ColorSphere® SC 187 Selva with moka ash base
Archibald Task Chair, Executive and Managerial versions, Pelle Frau® ColorSphere® SC 173 Glauco
Nymph medium table lamp, Pelle Frau® SC 68 Sahara / smoked lampshade



↑ Archibald Task Chair, Executive version, Pelle Frau® ColorSphere® SC 173 Glauco



↑ Peek-a-Book Large, Pelle Frau® ColorSphere® SC 187 Selva with moka ash base
Archibald Task Chair, Executive and Managerial versions, Pelle Frau® ColorSphere® SC 173 Glauco



↗ Peek-a-Book desk, Pelle Frau® Kenté Green color with moka ash base
Ginger small armchairs, Pelle Frau® Kenté Black color with moka ash base
Ren Bookcase, Pelle Frau® Kenté Green color with moka ash base



Peek-a-Book desk, Pelle Frau® Kenté Green color with moka ash base
Ginger small armchairs, Pelle Frau® Kenté Black color with moka ash base
Martha armchair, Tribal Velvet Green color with moka ash base
Ren Bookcase, Pelle Frau® Kenté Green color with moka ash base



↑ Martha armchair, Tribal velvet Green color with moka ash base



↑ Brera 90th Anniversary, Pelle Frau® ColorSphere® multicolor version

➤ Brera 90th Anniversary, Pelle Frau® ColorSphere® multicolor version
Squash Mirror, freestanding long version, Pelle Frau® ColorSphere®
SC 254 Steel Blue





↑ Brera 90th Anniversary, Pelle Frau® ColorSphere® multicolor version



↑ Archibald Bed, Pelle Frau® ColorSphere® SC 274 Fresco Blue
Stock'n Roll bedside table, Pelle Frau® ColorSphere® SC 68 Sahara
Nymph medium table lamp, Pelle Frau® ColorSphere® SC 68 Sahara /
smoked lampshade



↗ Archibald Bed, Pelle Frau® ColorSphere® SC 274 Fresco Blue
Stock'n Roll bedside table, Pelle Frau® ColorSphere® SC 68 Sahara
Nymph medium table lamp, Pelle Frau® ColorSphere® SC 68 Sahara /
smoked lampshade
Squash Mirror, freestanding long version, Pelle Frau® ColorSphere®
SC 254 Steel Blue



↑ ↗ Archibald Bed, Pelle Frau® ColorSphere® SC 274 Fresco Blue
 Stock'n Roll bedside table, Pelle Frau® ColorSphere® SC 68 Sahara
 Nymph medium table lamp, Pelle Frau® ColorSphere® SC 68 Sahara /
 smoked lampshade

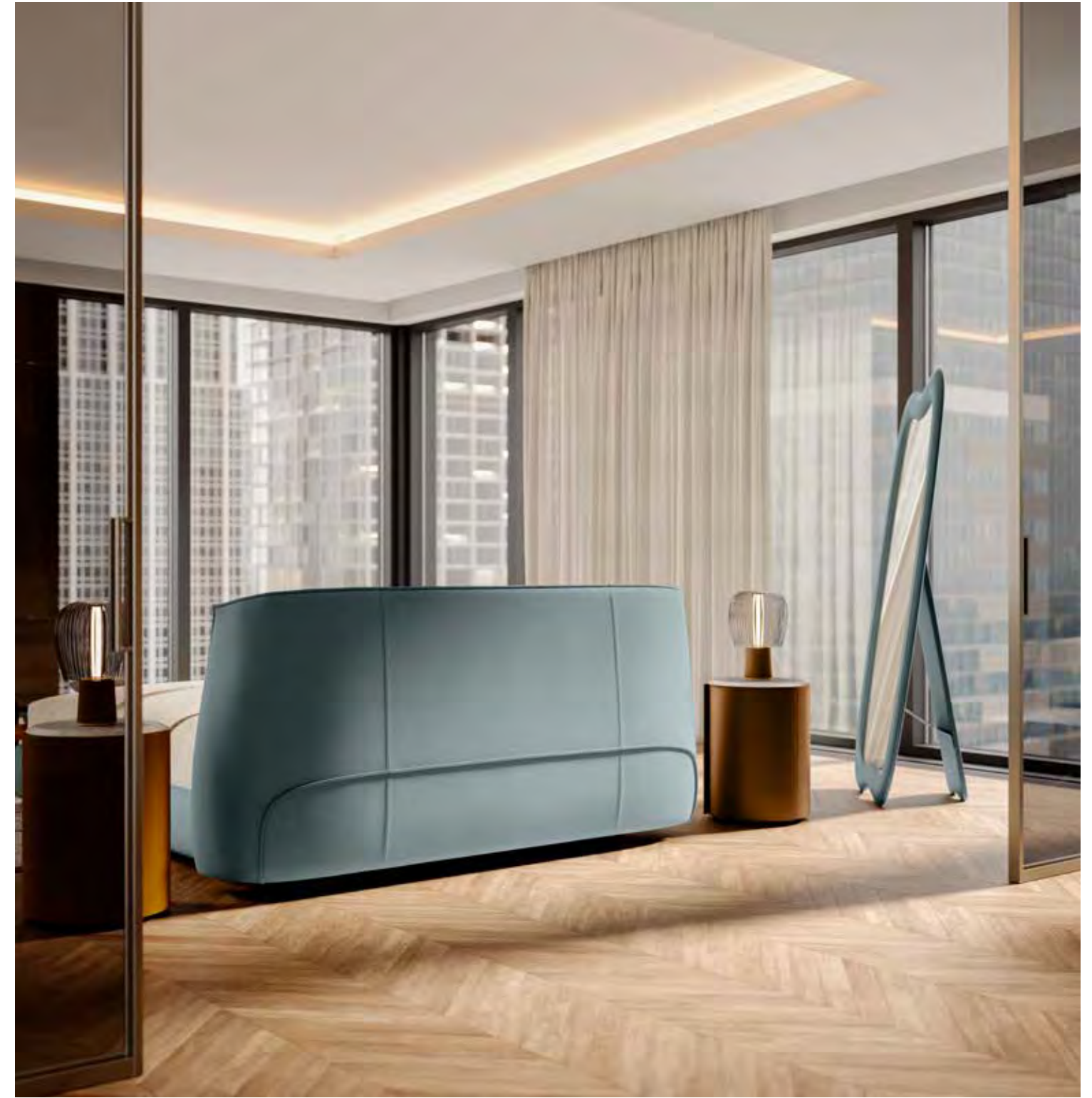

↗ Squash Mirror, freestanding long version, Pelle Frau® ColorSphere® SC
 254 Steel Blue



↗ Archibald Bed, Pelle Frau® ColorSphere® SC 274 Fresco Blue
Stock'n Roll bedside table, Pelle Frau® ColorSphere® SC 68 Sahara
Nymph medium table lamp, Pelle Frau® ColorSphere® SC 68 Sahara /
smoked lampshade
Squash Mirror, freestanding long version, Pelle Frau® ColorSphere®
SC 254 Steel Blue









Bretagne, one of Poltrona Frau's most-coveted sofas, now revealed in its latest version: Bretagne Gran Comfort, revamped in the three specifics of ergonomics, proportions and upholstery.



This oh-so-generous restyling literally means more of everything: abundant and more-structured cushions, horizontal seamed cushioning with enveloping shapes that are high enough to provide a headrest making the sofa even more comfortable (and utterly irresistible) for 24/7 chill-out time.

The sofa's iconic tub structure and legs remain unchanged. However, the inner cushioning has been plumped up to be much more generous and inviting: the backrest cushions have also been increased in size and padding to provide lumbar support and depth for a head rest. The seat cushioning is also more robust, with an elegant seam accentuated by top stitching which, in addition being easy-on-the-eye, also helps to retain the sofa's shape.



Poltrona Frau Style & Design Centre Bretagne Gran Comfort

The innovative design is enhanced by the new upholstery which, on the structural parts (base, sides and backrest) can also be selected in the brand-new Pelle Frau® Motif Knits in four different colours: Deep Lavender, Sesame, Gray Salt, Paprika. This nubuck leather is heat-embossed to replicate a twill weave pattern, and the striking three-dimensional tactile and visual effect creates a beautiful play of contrasts with the cushions in smooth glossy leather or fabric.



This is Happy Jack, designed by creative duo Ludovica Serafini + Roberto Palomba, which owes its name to the characteristic armrest with a smile-shaped curvature.

The Happy Jack family rightly claims its place in Imagine Versatility, one of Poltrona's Frau's key themes for 2024 that showcases utmost versatility and customisation. The newly-extended collection evolves with a series of elements which, whilst maintaining the same formal characteristics, stand out with a curvier and more enveloping line, generating an idea of playful ease and more intimate conviviality.

Ludovica Serafini
+ Roberto Palomba
Happy Jack





↑ Happy Jack sofa, fabric Mollis col. Slate / Pelle Frau® ColorSphere®
SC 279 Alchemy



↑ Happy Jack sofa, fabric Mollis col. Slate / Pelle Frau® ColorSphere®
SC 279 Alchemy

Taking a closer look at the new features: the 45° Corner Sofa, available with right/left armrest or without end panels, the Pouf designed with feet that match the sofa (also available in a Large version), plus of course, the super-comfortable reclining Chaise Longue with optional right-left armrest, or without armrest altogether.



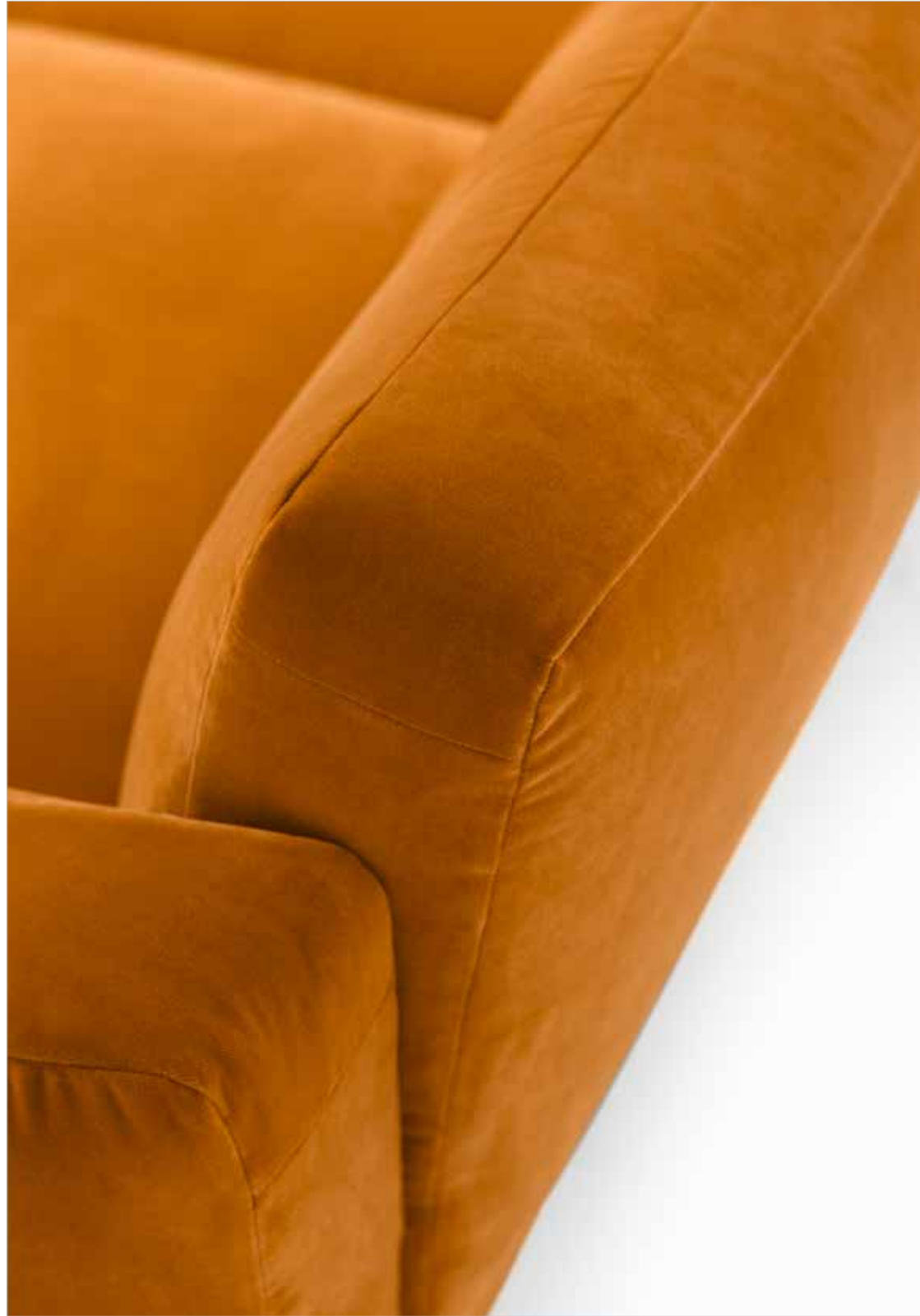



These new modules facilitate multiple novel configurations, making the range even more adaptable to different spaces and needs. Thanks to the sheer variety of exquisite details, formal elegance and versatile solutions Happy Jack becomes the epitome of Image Versatility, basking in the limelight of the Poltrona Frau living room.

The collection can be upholstered entirely in Pelle Frau® leather, in Pelle Frau® leather combined with fabric, or in Cuoio Saddle Extra for the structure and Pelle Frau® leather or fabric for the cushions. The reclining seat features an in-built motor within the seat cushion which enables it to be gently raised into different positions to suit the user, from reclining to fully risen. The movement is easily adjusted via wireless remote control. In the reclining seats, the padding and stitching differ from the static modules and sofas as they are specifically designed to be functional for movement.



The upholstery used for the Martha armchair is Velvet Fabric Tribal. The black Tribal pattern is digitally printed onto a piece-dyed monochromatic background in four vivid colours (Red, Green, Purple and Yellow). The special finishing gives the velvet a soft dense handle.

Poltrona Frau



Roberto Lazzeroni
Martha
Oswald Boateng x Poltrona Frau

The coveted Martha armchair - one of the most popular chairs in the Poltrona Frau catalogue - is now also presented in this new guise, which adds a touch of urbanity. The new version now flaunts a velvet interior, available in Red, Purple, Green or Yellow, with the external covering of the shell in Cuoio Saddle Extra, available in the shades currently on the price list.



↖ ↑ Martha armchair, Tribal velvet Green color with moka ash base

Poltrona Frau presents its new Parka modular seating system. A collection that inaugurates an exciting collaboration with the creative duo Draga & Aurel.

Parka pays homage to the iconic jacket. From pop stars to streetwear: in the '90s the Oasis frontman (who was highly influenced by Mod's '60s fashion) managed to take an everyday garment and make it cool.

The Parka jacket became the epitome of street style, a versatile, protective garment but soft and comfortable at the same time. Much like the iconic jacket, the Parka sofa coordinates effortlessly with all types of interiors and is extremely versatile, despite (or even because of) its strong personality. The soft lines and generously padded upholstery that skims the floor hint at comfort and relaxation. The unusual elliptical shape of the backrest, which inclines to become an armrest and then a seamless seat, creates a concave or convex space that is both audacious and welcoming, seamlessly coordinating with different styles of interiors.



Draga & Aurel
Parka

The Parka collection comprises modular elements: a concave or convex armchair without armrests or with a terminal armrest, the latter also in a maxi version, either right-side or left-side. It can be upholstered either entirely in Pelle Frau®, in the various types of leather present in the catalogue, or in a leather + fabric combination. In this case the leather is applied to the external structure, while the fabric is applied to the seat, backrest and armrest. Tone-on-tone top stitching completes the aesthetic.

Poltroña Frau



Softness, boldness and fun all in the one collection: Squash, designed by British artist Faye Toogood, captivates with its flippant nonchalance, starting with its playful and sensual name, reflecting a soft and sculptural approach to design.

The collection is comfortable and cozy right from the first glance. Exuberant and bold, yet gentle and reassuring forms interact with a mix of soft and rigid materials. The flowing contours and soft padding disrupt the static essence of formal furniture. Traditional English folk elements are reworked and combined with 1970s influences. Squash suggests a notion of simple, contemporary elegance based on unique objects that work well alone, together, or combined with other furnishings.



Faye Toogood Squash



The Squash armchair, with its generous and snug contours, is made with a rigid trestle frame made of polimex®, which supports the large, soft cushioning upholstered in Pelle Frau® or a combination of leather-fabric, with removable covering. The frame and legs are lightly padded, making them pleasant to the touch. The legs of the base are upholstered in leather. The seat and armrest cushioning

are made of polyester wadding and differentiated-density polyurethane foam for greater comfort. The seat base is made of birch plywood. The color combinations recommended by the designer for the Squash armchair are Cream, Sage, Blue and Brown.





The Squash occasional table showcases a bold and original design, with two lacquered wood blocks separated by a central cushion, upholstered in Pelle Frau® ColorSphere leather to match the color of the blocks. The occasional table is available strictly in four color combinations: Cream, Sage, Blue and Brown. A support mat in Pelle Frau® ColorSphere leather is available as an optional, matching the color of the table's central cushion.

The cozy Squash ottoman, perfectly paired with the armchair in the same collection, features a birch plywood frame and leather covering. The legs are lightly padded in polyurethane foam, making them pleasant to the touch. The ottoman cushion, with padding in polyurethane foam and polyester wadding, is removable and can be fully upholstered in Pelle Frau® leather or fabric. Just like the armchair, the color combinations recommended by the designer are Cream, Sage, Blue and Brown.





The Squash Rug in the similarly named collection features a checkerboard motif inspired by old English patchwork chairs.

Each square is hand-painted and the artwork translated into fabric using the traditional Berber knotting technique.

Faye Toogood Squash Rug



The Squash Rug is handmade and is available in different sizes and a range of colors. The dyeing process and use of natural fibers replicate the hand-painted design as faithfully as possible, while the plush fleece and subtly blended threads evoke the nuanced look of brushstrokes. All in accordance with the highest standards of sustainability.



The Squash wall ,mirror is upholstered in leather and replicates the curvy and flowing contours of its namesake collection.

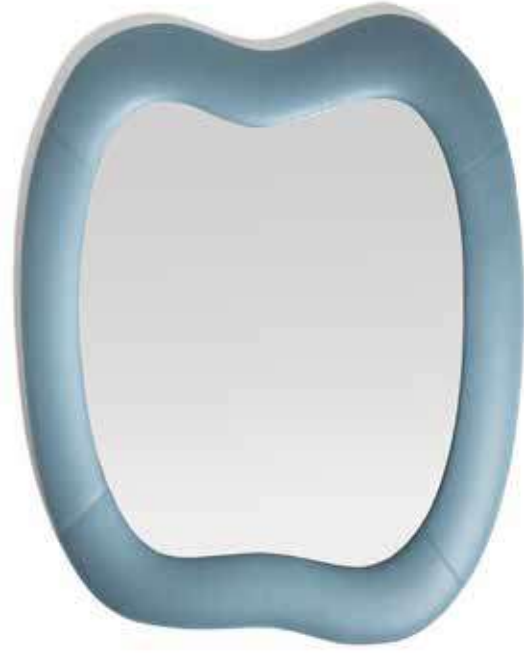

It is characterized by a contrasting rigid material (glass) and the soft, tactile, rounded frames covered in Pelle Frau ColorSphere® leather. The mirror, measuring 1000x800 cm, is available in the colors SC 92 Garnet, SC 67 Chiodi di Garofano and SC 254 Steel Blue.



Faye Toogood Squash Mirror



The Squash full-length mirror is upholstered in leather and replicates the curvy and flowing contours of its namesake collection. It is characterized by a contrasting rigid material (glass) and the soft, tactile, rounded frames covered in Pelle Frau ColorSphere® leather.

The full-length mirror can be wall-mounted or freestanding on an adjustable tripod, purchased separately. The mirror is available in the colors SC 92 Garnet, SC 67 Chiodi di Garofano and SC 254 Steel Blue.

↑ ↗ Squash long mirror with freestanding stand, Pelle Frau® ColorSphere® SC 254 Steel Blue



The Squash pocket mirror is upholstered in leather and replicates the curvy and flowing contours of its namesake collection. It is characterized by a contrasting rigid material (glass) and the soft, tactile, rounded frames covered in Pelle Frau ColorSphere® leather.

Convenient travel or pocket mirror. The double mirror is housed in a folding leather cover. It measures 8.5 x 8.5 cm (closed) and 17.9 x 8.5 cm (open). Available in the colors SC 92 Garnet, SC 67 Chiodi di Garofano and SC 254 Steel Blue.



Numbered individually and upholstered with Pelle Frau® printed with Fornasetti's Sole e Nuvole patterns, the Vanity Fair XC Imagine Edition armchair is available in a limited edition of 50 pieces



The frame is made of seasoned beech solid wood. It is padded using both hand-modelled vegetable horsehair and rubberized horsehair while the cushion of the seat is made of goose feather, with an expanded polyurethane insert to ensure it maintains its shape over time.

The seat, backrest and armrests come with springing made of biconical hand-tied steel springs fastened to jute belts. The rear and sides of the armchair are refined by a row of leather-covered nails. The lining comes with a Pelle Frau® Impact Less leather, that is printed digitally with slightly relief effect. The rear of the backrest features a gun barrel grey finish plate bearing the Fornasetti x Poltrona Frau® logo and serial number.



Renzo Frau Vanity Fair XC Imagine Edition



A larger version of the Dining chair, now available with extra-comfortable proportions. The wider seat and higher backrest hug and support the body to create a sensation of extreme comfort.

The new Archibald chair is available upholstered in leather or fabric. The Pelle Frau® version is enhanced with contrasting top-stitching that highlights its contours. The Archibald Large Dining Chair is available with a burnished or titanium powder-coated metal base.



Jean-Marie Massaud
Archibald Large
Dining Chair



Teamwork makes the dream work...
and the collaboration between Ceccotti
Collezioni and Poltrona Frau, created
in 2023 with the launch of the DUO
collection, continues with an extended
range of products.

This year, the focus is on the home
dining area with new proposals, as
always, designed by Roberto Lazzeroni.
Kudos, firstly, to the gorgeous padded
chair as one of the new features
for this season, available with and
without armrests, combined with the
dining table in four variants created
by Ceccotti Collezioni. The DUO
range is completed by the Bench, in
more comfortable dimensions, and
the Cabinet with a new finish for the
external covering.

Roberto Lazzeroni
DUO
Chair/Small armchair

Poltrona Frau



- ↑ DUO Small armchair, Fabric Wool Satin Light Marengo with ash in a wenge stain structure
- ↑ DUO Chair, Pelle Frau® SC 66 India with ash in a wenge stain structure

134

The 2024 Imagine Collection

DUO Chair/Small armchair

135



The Duo Chair, created by Poltrona Frau, has a padded seat with sinuous and enveloping lines. Everything about this chair exudes softness juxtaposed with charming playfulness: the inclined rear legs give momentum to the high-back chair or to the armchair which extends obliquely with two endearing 'ears'.

The convex seat plays with the slight concavity of the backrest, shifting the volumes. The plush padding, available completely covered in Pelle Frau® or in woven fabric, adds indulgent comfort as an invite to laid-back conversation. The legs in solid ash wood are available in a Wengé or Moka stained finish, dyed to sample shade or lacquered to match a RAL colour chart sample.



↑ DUO Chair, Pelle Frau® SC 66 India with ash in a wenge stain structure

↗ DUO Small armchair, Fabric Wool Satin Light Marengo with ash in a wenge stain structure

Ginger and Ginger Ale, the two compact armchairs upholstered in the new Boateng version, have an external shell in Pelle Frau® Kenté leather in the six available colours.

The interior of the body is in Pelle Frau® SC. The colour of the stitching matches the colour of the leather that it contours. Both armchairs are available in all the variations on the price list, i.e. fixed or swivel armchair for Ginger, while Ginger Ale can be ordered with a four-legged wooden or metal base, a four-spoke armchair with metal column, or five-spoke armchair with metal castors.

Poltrona Frau



Roberto Lazzeroni
Ginger & Ginger Ale
Oswald Boateng x Poltrona Frau



↑ Ginger Ale armchair, Pelle Frau® Kenté Purple color



The success of the compact Nice chair is due to its striking curved ergonomic shape. With comfort and support in mind, the backrest and seat are designed as two flexed shapes that overlap in two folded layers, creating a void in the lower part of the backrest which becomes a distinctive feature.

The softly draped upholstery, either in Pelle Frau® or woven fabric, accentuates the armchair's relaxed and inviting curves which can also be covered in leather on the external part of the backrest. The extension of the collection with a new base in solid ash wood was created with versatility in mind to facilitate coordination with a wider choice of wooden tables in the catalogue.

The base and legs in solid ash wood are available in Natural finish, Wengé/ Moka stained, dyed to sample shade or lacquered to match a RAL colour chart sample.



GamFratesi Nice



Peek-a-Book, the intriguingly-named desk designed in 2021 by Roberto Lazzeroni, makes an impressive return and flaunts a larger version for the 2024 Imagine Collection, with a desktop generously extended by approx. 30 cm compared to the current version.



Peek-a-Book is constructed of poplar plywood panels counter-plated in MDF. The curved anterior edge, made of moulded polyurethane foam, folds forwards to form the edge of the desk, and conceals the drawers and interior accessory compartments just like a closed book.



↑ ↗ Peek-a-Book desk, Pelle Frau® ColorSphere® SC 254 Steel Blue with wenge ash base
Archibald Task Chair, Executive version, Pelle Frau® ColorSphere® SC 254 Steel Blue

Roberto Lazzeroni Peek-a-book Large

Peek-a-Book base structure consists of an easel made from a triangular-section of Wengé-stained or Moka-stained solid ash wood. The drawer fronts are made of MDF dressed in Pelle Frau® leather to match the covering of the shaped top made of poplar plywood panels counter-plated in MDF. The desk top, drawer fronts, sides and access doors to the rear compartments are covered with Pelle Frau® ColorSphere®.

The two drawer fronts conceal compartments designed for a cable raceway that is accessible via side panels. The desk is available with the same options as the standard version currently on the price list. This new version is, however, equipped with a different sized pen storage tray to fit the new dimensions of the drawer: Large Pen Holder, covered in Pelle Frau® ColorSphere® leather.



↑ Peek-a-Book desk, Pelle Frau® ColorSphere® SC 254 Steel Blue with wenge ash base. Detail of the drawer

To celebrate its 90th anniversary, the iconic Brera bench, designed by Guglielmo Ulrich and reissued by Poltrona Frau, marks the special occasion with a superb multi-coloured edition.

The chromatic choices from the Pelle Frau® ColorSphere® form an attractive multi-coloured effect that further enhances the artisanal mastery of the weaving. Robust leather strips - in SC 66 India tan shade - form the vertical weft of the seat, and flow coherently across the entire length of the bench to create a streamlined profile, and maintain the practical utility of the bench, respecting the balance between the formal rigor and the chromatic eclecticism so typical of Guglielmo Ulrich's work.

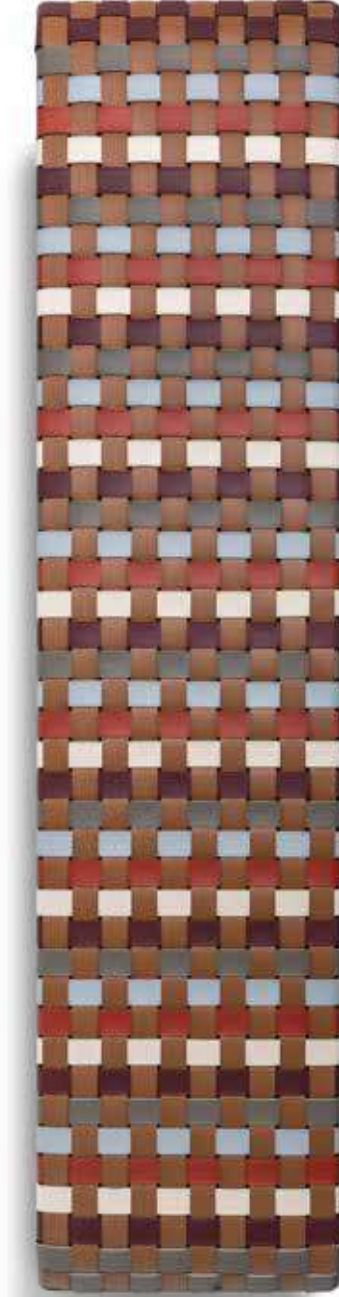
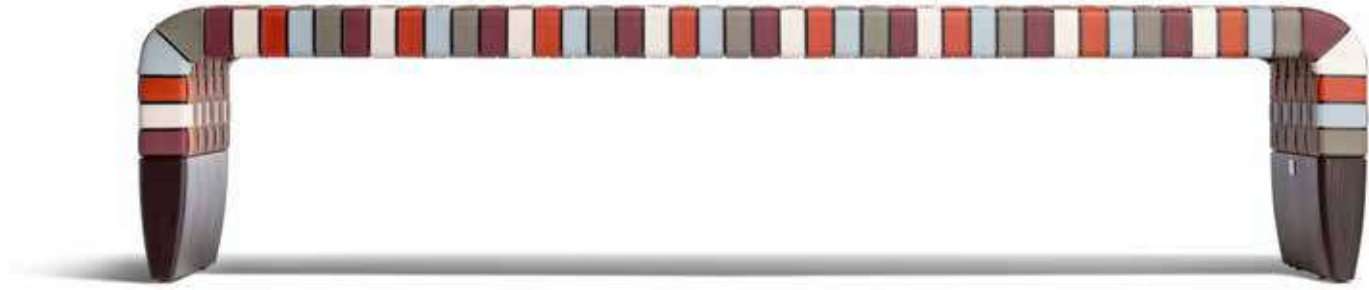

Guglielmo Ulrich
Brera
90th Anniversary Edition

Whilst the horizontal warp strips, woven into the weft, form a melodic sequence of warm and cool shades - Darsena, Bardiglio, Cocciopesto, Avorio and Garnet - sourced from the Pelle Frau® ColorSphere®. The two natural shades and the three mid-hues complement and contrast each other, to show off the regularity and precision of the weaving, creating an extremely modern geometric texture. The two tapered and lightweight side supports are in solid ash wood with a Wengé finish, also available, upon request, in Moka.

Brera 90th Anniversary is a special edition; orders will be taken from the inauguration of the Salone del Mobile up until December 31st 2024. The bench is authenticated by an unobtrusively-placed metal plaque. Alongside the 90th Anniversary edition, a new plain-colour version in Pelle Frau® SC also makes its debut, which joins the style in Cuoio Saddle Extra already present in the catalogue.



Archibald now makes its stylish arrival in the night zone with a bed that flirts with the spirit of the collection...Imagine refined elegance. A soft seductive bedframe is embraced by a high curved leather headboard that slopes subtly downwards to hug the two corners.

The vertical ripples of the plush leather, together with the tone-on-tone stitching that trims the headboard, hit the sweet spot of sophisticated luxury for a bed that, despite its confident contours, conveys intimacy and warmth. The Archibald bed is available in five sizes, two different height measurements from the ground, and a practical version with retractable storage drawer is also an option.



Jean-Marie Massaud Archibald Bed

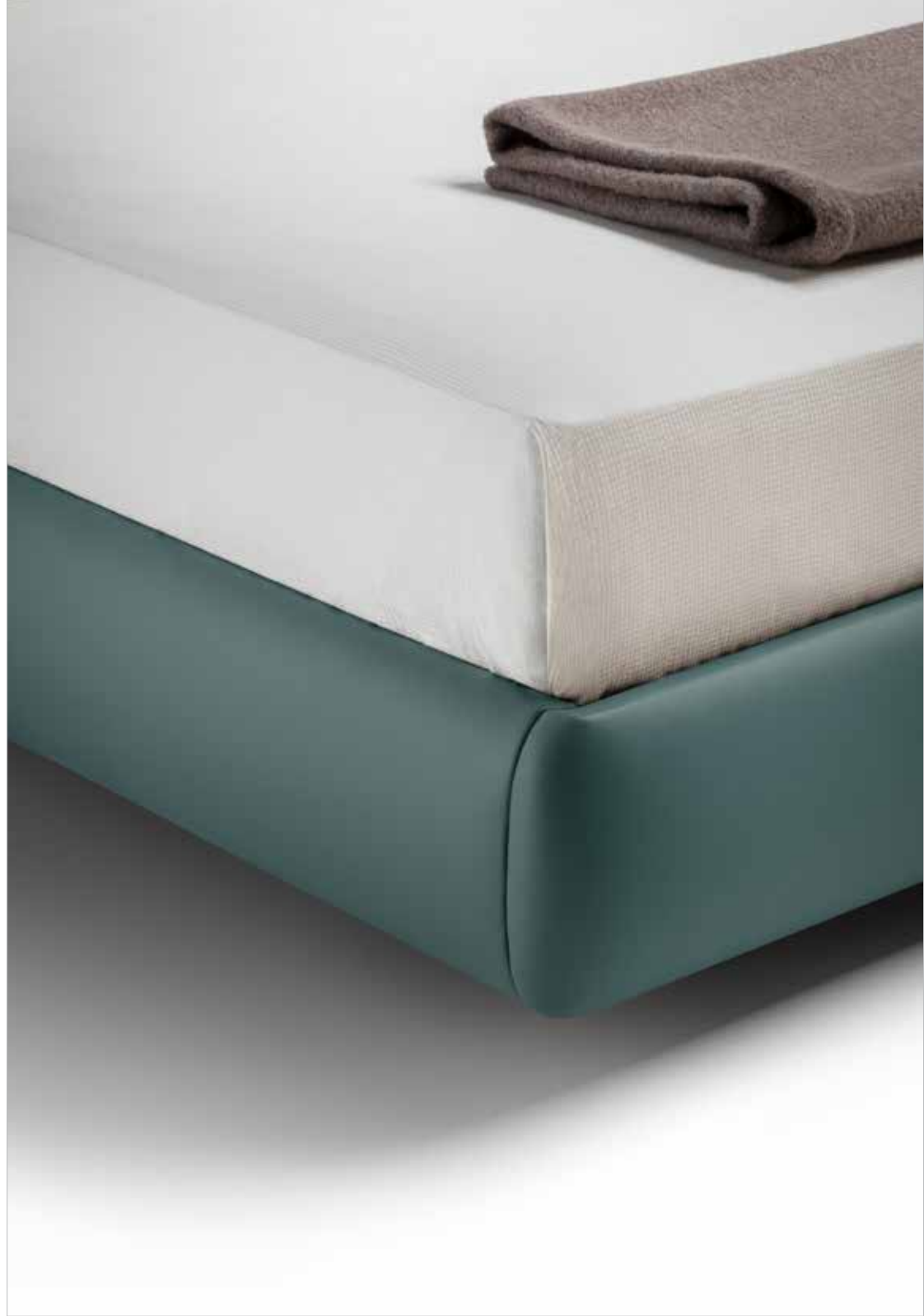

It is entirely upholstered in Pelle Frau® ColorSphere® or Nest, with the rear of the bed also available in the Poltrona Frau Jacquard fabric version which is more practical if placed adjacent to a wall. The model with storage drawer is only available in the version suitable for a 170 cm mattress.

The drawer can be accessed by lifting the bed base by means of two leather handles which activate a gas spring feature which has the option of a single or double opening movement.



Designed by Sebastian Herkner, Stock'n Roll comprises a collection of storage units inspired by jewelry boxes, characterized by a sleek but exclusive design featuring intricate details and luxury materials.

Stock'n Roll can be placed next to an armchair or used as a bedside table on either side of the bed. It is cylindrically shaped with the edge of the cover deviating slightly from the body, forming a handle inviting it to be opened.

Sebastian Herkner Stock'n Roll



The supporting frame and door of the Stock'n Roll bedside table are made of curved beech plywood and solid beech wood. The upholstery is in Pelle Frau® leather, with tone-on-tone stitching. The storage unit is available with left or right opening. With a single gesture, the door featuring a small inner tray opens to reveal an equipped compartment complete with organizer shelf. The shelf and tray are made of birch plywood and finished to match the outer surface. The top can be upholstered in Pelle Frau® leather to match the inner and outer surface, or in precious semi-gloss marble.



Nymph is inspired by the eponymous female deities from ancient Greek mythology, benevolent personifications of nature at the service of human beings.

Inspired by the concept of a gentle presence that accompanies our daily life, this blown glass lamp with a delicately-pleated lampshade floats weightlessly on its leather-covered base. As a tribute to the classic leather tufted button on Poltrona Frau upholstery, the on/off and dimmer switch is designed as a brass button embedded in the lampshade base. When switched on, the illumination transforms the design object into a graceful incandescent sculpture, reminiscent of gentle ethereal maiden.



↑ **Nymph** small table lamp, Pelle Frau® SC 66 India / smoked lampshade

↗ **Nymph** small table lamp, Pelle Frau® SC 66 India / smoked lampshade
Nymph medium table lamp, Pelle Frau® SC 66 India / satin Milk White lampshade

Sebastian Herkner Nymph



Available in Pearl and Fumé finishes, the blown glass lampshade is a single cylinder shape with vertical bevelled ribbing that creates a unique visual illumination effect. The lamp frame is a cylindrical tube in polymethyl methacrylate (PMMA) with a LED module encapsulated in a base shaped like a truncated cone.

This is covered in Pelle Frau® ColorSphere® available in a choice of colours - Seppia, Maggese, Sahara, Ginger Bread, Fresco Blue - offset with contrasting stitching and metallic brass details. The lamp has an on/off touch button dimmer switch. LED 18W 3000K. 25W.





↑ Desk Blotter, Pelle Frau® ColorSphere® SC 31 Quarzo Fumé and SC 66 India

↑ Single Pen Holder, Pelle Frau® ColorSphere® SC 66 India
 A4 Paper Tray, Pelle Frau® ColorSphere® SC 31 Quarzo Fumé
 Leather Mouse pad, Pelle Frau® ColorSphere® SC 31 Quarzo Fumé
 Flat Pen Holder, Pelle Frau® ColorSphere® SC 66 India
 Desk Blotter, Pelle Frau® ColorSphere® SC 31 Quarzo Fumé and SC 66 India



Giobagnara x Poltrona Frau Office Collection

The Office Collection, also created in cobranding with Giobagnara, are accessories designed to upgrade the office or workstation environment.

From the pen holder to A4 folder, mouse pad, desk mat, waste paper basket, letter holder and laptop stands... all covered in Pelle Frau® leather in shades of India or Quartz Smoky, and carefully curated with top stitching in every minute detail.





↑ Laptop Tray, Pelle Frau® ColorSphere® SC 31 Quarzo Fumé and SC 66 India



↑ Flat Pen Holder, Pelle Frau® ColorSphere® SC 31 Quarzo Fumé and SC 66 India



↑ Envelope Holder, Pelle Frau® ColorSphere® SC 31 Quarzo Fumé



↑ Mouse pad, Pelle Frau® ColorSphere® SC 31 Quarzo Fumé and SC 66 India



↑ A4 Paper Tray, Pelle Frau® ColorSphere® SC 31 Quarzo Fumé



↑ Single Wastepaper Bin, Pelle Frau® ColorSphere® SC 31 Quarzo Fumé and SC 66 India

Range extension also for the *Pet Collection*, designed by Poltrona Frau Style & Design Centre.



↑ Harness jacquard, Camel version



↗ Harness jacquard, Burgundy version
Leash jacquard, Burgundy version

Poltrona Frau Style & Design Centre Pet Collection

The collar is a jacquard fabric strap with Pelle Frau® loops in the 3 colours - Ume, Cypress and India - in the same fabric combinations as the leash. It has a fixed loop + sliding loop with lock, and a D-ring to enable the leash to be attached. It is available in four different sizes to suit all pets, from Extra Small to Large.

The harness, with adjustable straps on the back and chest is also available in four sizes, and is made with the same materials and finishes as the collar and leash. The hardware is made of brass polished with galvanized nickel.



↑ Collar jacquard, Green, Camel and Burgundy versions



↑ Harness jacquard, Burgundy and Camel versions

The adjustable leash, in woven leather with a tear-resistant reinforcement, has a Pelle Frau® handle available in the following combinations: Ume combined with the burgundy and yellow strap; Cypress, combined with the green and camel strap, and India, combined with the camel and green strap. The finishes are in galvanized brass, the carabiner is in polished nickel and the logo medal is in die-cast zamak with polished nickel finishes. The leash is available in two sizes: Small and Medium.



↖ ↑ Leash jacquard, Burgundy version



The cushion is available in two versions - Medium and Large - in Beige Beady fabric (67% viscose, 33% cotton). The cover is easily removable and can be used both with or without the Dog Bed.



The pet bowl is in lead-free glazed ceramic, made with the three-phase firing technique. Available in a cream shade, it can be coordinated with the printed decorative non-slip mat, in eco-leather and polyester.



The new version of Tableau, the decorative wall panel designed by Simona Cremascoli, is presented in the new Pelle Frau® Nest colours for this year. Intense and bright hues compose a geometric collage of colours evoking the Bauhaus chromatic palettes.



Simona Cremascoli Tableau N'est Season

A beautifully-laid table is as much a part of the guest experience as the food being served, and expressing care and attention to your guests is further enhanced with the Tableware line accessories in cobranding with *Giobagnara*.

Sets of rounded or rectangular trays, coasters, placemats, napkin holders, bottle coolers, placemats and champagne buckets with stands all add refinement to even the simplest dinner. The upholstery details are in soft Pelle Frau®, in India or Quarzo Fumé shades.



Giobagnara x Poltrona Frau
Tableware Collection

↑ Tableware Collection: Bottle Cooler, Underplate, Napkin Ring, Bed Tray, Pelle Frau® ColorSphere® SC 31 Quarzo Fumé

↗ Tableware Collection: Champagne Bucket, Wallet Champagne Bucket, Pelle Frau® ColorSphere® SC 31 Quarzo Fumé







↑ Napkin Ring, Pelle Frau® ColorSphere® SC 66 India
Underplate, Pelle Frau® ColorSphere® SC 31 Quarzo Fumé



Water Illusion, the vase collection by Assia Karaguiozova, captivates with a new variant in tones of green, *Emerald Whispers*.



Assia Karaguiozova
Water Illusion

Entirely handmade by Italian master glassmakers with the complex Pâte de verre technique, the Bulgarian designer's vases, artisan-made in Venetian glassworks, have unique shapes making each piece a limited-edition.

The thick and transparent irregular wavy glass 'petals' whisper the language of the waves. In contact with light, the interior double texture evokes the ripple effect of water on a surface. The four sculptural models push the boundary between art and design, and the two vase and two bowl styles are available in two different formats.



Archibald Managerial and Archibald Executive also introduce a tad of contemporary elegance to the home office sector.

Based on meticulous ergonomic research, the new Archibald armchairs are designed to accompany the body's full range of movements, and support correct posture for the desk user. Archibald Managerial and Archibald Executive have a base in die-cast aluminium equipped with a swivel mechanism that enables the armchair to be rotated 360° with complete height adjustment.

Poltroa Frau



Jean-Marie Massaud Archibald Task Chair

The 2024 Imagine Collection

Archibald Task Chair

The base is available in the following finishes: polished aluminium and black painted aluminium, and can always be supplied with different types of wheels or swivel rollers. Both home-office versions of the Archibald are equipped with: gas spring seat height adjustment; tilt tension feature for backrest and seat which can be adjusted to increase or decrease the force needed to tilt, and enables the armchair to easily follow the movement of the body; 360° rotation around its vertical axis.

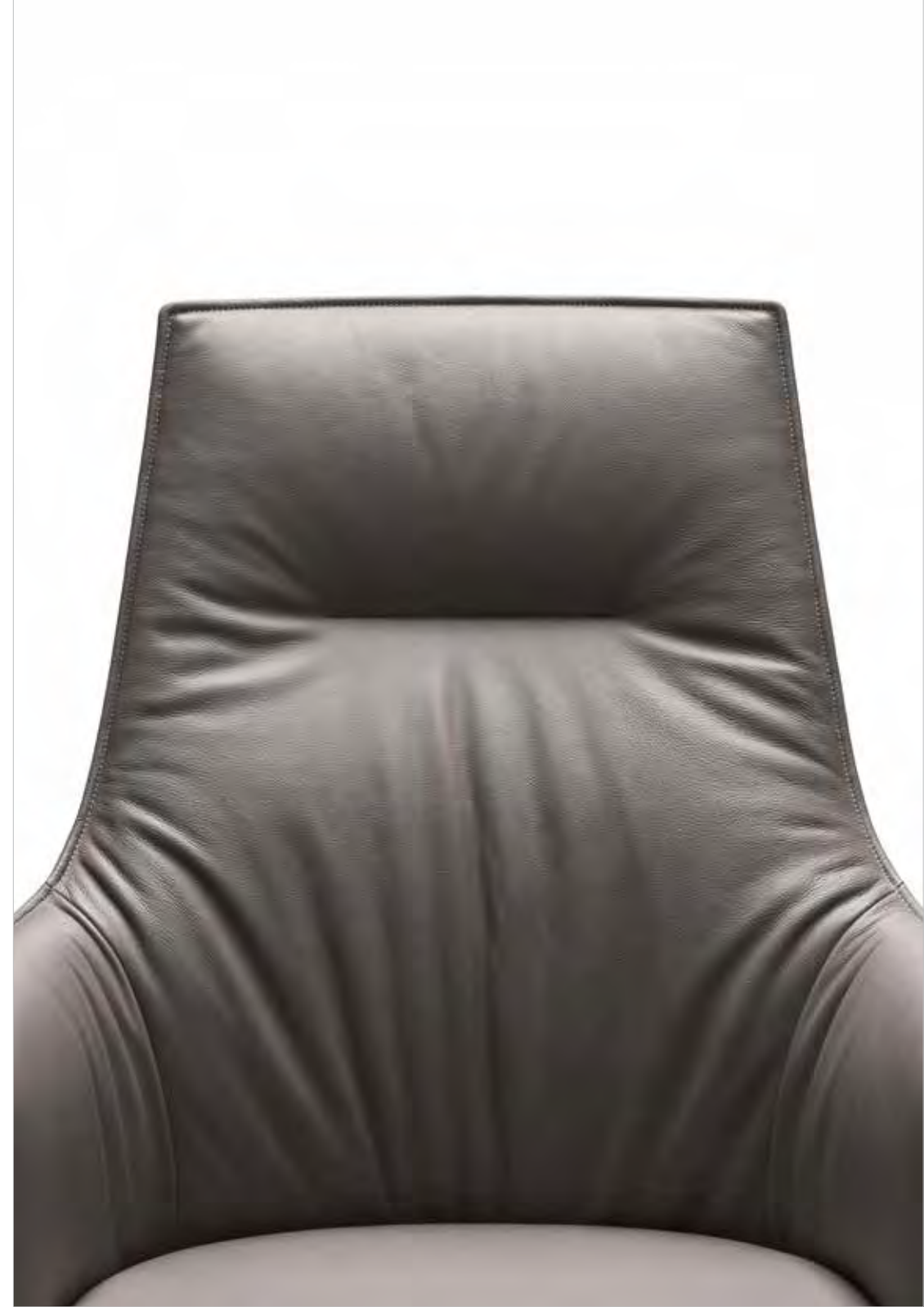



Jean-Marie Massaud Archibald Task Chair



Leisure time goes big time with the Pillow armchair by Poltrona Frau in its new improved version specifically designed for home Cinemas.



Pillow Cinema armchair is meticulously studied to incorporate the latest in design and technology offering an authentic high-level home theatre experience.



Poltrona Frau Style & Design Centre Pillow Cinema

Thanks to three separate mechanisms that enable optimal adjustment of the back, foot and headrest, Pillow is fully reclining. The push-button panel, placed internally on the armrest facilitates control of the various commands and, as the name suggests, the Home button simultaneously returns all the elements to the starting position.

Pillow can also be customized with accessories such as a Cinema absolute- must-have drink holder cooler/heater with wireless charging, an armrest lamp with a USB-A charging station, and a practical leather over-armrest that serves as a side table for small items.





Pillow Cinema is available with various seating options. In addition to the single armchair for solo viewing and the cosy Love Seat (two adjoined seats without a central armrest), it can be compiled in numerous ways by placing several armchairs side by side or combining them with the Love Seat version.

The controls for head, back and footrest can be mains or battery-powered and, depending on the version chosen, the appropriate transformer or battery charger must be purchased apart. Armchairs equipped with electrical accessories can only be powered by the mains (battery power is excluded), and the chair can be upholstered in either Pelle Frau® or a choice of fabric. Pillow can be freestanding or permanently fixed to the ground.





↑ ↗ Pillow Cinema, Pelle Frau® ColorSphere® SC 28 Seppia.
Detail of the back of the armchair

Poltrona Frau 2024 New Upholsteries

**Pelle Frau®
Kenté leather**

Black
Blue
Green
Purple
Red
Yellow

**Pelle Frau®
Motif Knits leather**

Deep Lavender
Grey Salt
Paprika
Sesame

**Pelle Frau®
Nest leather**

Adularia
Alamandino
Azzurrite
Cinabro
Giada Imperiale
Pietra Sole
Quarzo Rosa
Zircone

2024 Indoor Fabrics

Haruka

Pollen
Whity
Peach Brown
Dusty Blue

Kalahari

Cocoa
Coral
Forest
Gold
Greige
Ivory
Melange Grey
Pistachio
Royal Blue
Salmon

Suri

Mahogany
Beige
Azul

Wool Satin

Cayenna
Dark Marengo
Honey
Light Marengo
Nougat
Peacock
Taupe
Tobacco

PELLE FRAU® LEATHER - 2024 NEW LEATHERS

PELLE FRAU® KENTÉ

Last, but by no means least, the new Pelle Frau® Kenté uses digital printing to recreate the abstract motifs and bright or dark colours of the traditional African Kenté fabric on leather. The patterns have a strong symbolic meaning in Ghanan cultural heritage, and are worn on certain ceremonial occasions. A variant that we find in the six skin tones: Black, Red, Yellow, Purple, Blue and Green. Ozwald Boateng has reinterpreted the textile pattern specifically for this leather upholstery, which acquires a particularly captivating intensity thanks to the innovative printing process and use of vibrant colours. The elegant Ren bookcase, the Peek-a-Book desk and the Ginger and Ginger Ale armchairs all make their entry into the Boateng collection with this new upholstery.

PELLE FRAU® NEST IMPACT LESS

Rich, strong, solid, yet incredibly soft and silky to the touch, Pelle Frau® Nest Impact Less becomes Impact Less, meaning tanned without chromium and through an innovative process that reduces water and chemical usage and uses 100% renewable energy sources. A process that, besides being more environmentally friendly, enhances the intrinsic qualities of leather. Pelle Frau® Nest feels softer to the touch, thanks to a fuller and rounder hand. The greater three-dimensionality and silkiness of the surface are enhanced by the shiny and homogeneous finish. The color palette also renews, adding to twelve existing shades, eight new, intense, and luminous colors.

PELLE FRAU® MOTIF KNITS

A particularly interesting tactile and visual effect characterizes Pelle Frau® Motif Knits, a covering created through an innovative 3D printing process that simulates a relief woven pattern ("twill"), also used in fabric printing, evoking the world of wicker and basketry. Pelle Frau® Motif Knits, obtained from a hot digital printing process, draws inspiration from the fashion world to reproduce a pattern similar to weaving, with a three-dimensional effect that is extremely contemporary on its own or combined with smooth leather.

POLTRONA FRAU FABRICS - 2024 NEW FABRICS

HARUKA

Haruka is the bouclé fabric made through a broad, discontinuous spinning on a plain, unbleached linen canvas. The result is a textured and three-dimensional-looking material. Irregular in its craftsmanship and rich in texture, the Haruka fabric is designed to dress the products with rich, layered visual and tactile sensations reminiscent of the world of fashion and haute couture.

KALAHARI

The characteristic irregularity of the fibers gives Kalahari a particular textured and flame-like appearance. The weave of warp and weft creates a small relief, similar to a rice grain, which enlivens the appearance of this faux fil-à-fil fabric and gives the surface a three-dimensional aspect, further enhanced by a slight sheen. Kalahari is available in a chromatic range of ten colors.

SURI

As soft and tender as a teddy bear, the Suri fabric is composed of yarns of various kinds, with the protagonist being a substantial and precious Alpaca bouclette. This precious material, originating from Peru and spun in Italy, gives life to a soft, textured, and refined Bouclé. Ideal when paired with leathers, Suri is available in the classic Natural Beige as well as the new shades of Sky Blue and Mahogany.

WOOL SATIN

Wool Satin has an extremely pleasant, soft, and cool hand feel. It is obtained from densely woven fine Merino wool satin, for an optimal, soft, and firm drape. Thanks to its elasticity and abrasion resistance, Wool Satin is ideal for covering any type of upholstery. The color range includes eight intense colors, from neutral shades with mélange yarns to brighter solid hues.

PELLE FRAU® LEATHER - 2024 NEW LEATHERS

PELLE FRAU® KENTÉ

La nuova Pelle Frau® Kenté, infine, utilizza la stampa digitale per ricreare su pelle la grafica del tradizionale tessuto Kenté africano, caratterizzato da motivi astratti e da colori intensi, chiari o scuri, dal forte significato simbolico, tipicamente indossati nelle occasioni formali. Una varietà che ritroviamo nelle sei tonalità della pelle: Black, Red, Yellow, Purple, Blue e Green. Ozwald Boateng ha reinterpretrato il motivo tessile appositamente per questo rivestimento in pelle, che grazie al processo di stampa innovativo e alle cromie vivaci acquista una particolare intensità. La libreria Ren, la scrivania Peek-a-Book e le poltroncine Ginger e Ginger Ale entrano nella collezione Boateng con questo nuovo rivestimento.

PELLE FRAU® NEST IMPACT LESS

Ricca, forte, solida, eppure incredibilmente morbida e setosa al tatto, Pelle Frau® Nest Impact Less diventa Impact Less, ovvero concziata senza cromo e attraverso un procedimento innovativo che riduce l'uso di acqua e sostanze chimiche e utilizza fonti di energia rinnovabile al 100%. Una lavorazione che, oltre ad essere più rispettosa dell’ambiente, esalta le qualità intrinseche del pellame. La Pelle Frau® Nest sembra infatti più soffice al tatto, grazie a una mano più piena e rotonda. La maggiore tridimensionalità e la setosità della superficie è esaltata dalla finitura lucente e omogenea. Anche la palette cromatica si rinnova aggiungendo a dodici tonalità già esistenti, otto nuovi colori, intensi e luminosi.

PELLE FRAU® MOTIF KNITS

Un effetto tattile e visivo particolarmente interessante caratterizza la Pelle Frau® Motif Knits, rivestimento realizzato grazie a un’innovativa stampa 3D che simula un motivo di intreccio a rilievo (“twill”) utilizzato anche nella stampa dei tessuti e che evoca il mondo del vimine e delle cesterie è Pelle Frau® Motif Knits, ottenuta da un procedimento di stampa digitale a caldo, trae ispirazione dal mondo della moda per riprodurre un motivo simile all’intreccio, con un effetto tridimensionale che risulta estremamente contemporaneo da solo o abbinato alla pelle liscia.

POLTRONA FRAU FABRICS - 2024 NEW FABRICS

HARUKA

Haruka è il tessuto bouclè realizzato attraverso una filatura ampia e discontinua su una tela in puro lino greggio. Il risultato è un materiale dall’aspetto materico e tridimensionale. Irregolare nella sua artigianalità e ricco di texture, il tessuto Haruka è destinato a vestire i prodotti regalando sensazioni visive e tattili ricche e stratificate, riconducibili al mondo della moda e dell’haute couture.

KALAHARI

La caratteristica irregolarità delle fibre dona a Kalahari una particolare texture materica e fiammata. L’intreccio di trama e ordito crea un piccolo rilievo, simile a un chicco di riso, che movimenta l’aspetto di questa tela fil-à-fil finto unita e conferisce alla superficie un aspetto tridimensionale, ulteriormente esaltato da una leggera brillantezza. Kalahari è disponibile in una gamma cromatica di dieci colori.

SURI

Morbidissimo e tenero come un orsetto, il tessuto Suri è composto da filati di varia natura, in cui protagonista è una consistente e preziosa bouclette di Alpaca. Materiale prezioso proveniente dal Perù e filata in Italia, dà vita a un soffice Bouclé, materico e raffinato. Ideale in abbinamento alle pelli, Suri viene proposto nel classico Beige naturale e negli inediti Azzurro e Mogano.

WOOL SATIN

Wool Satin ha una mano estremamente piacevole, morbida e fresca al tatto. È ottenuto da raso di finissima lana Merinos densamente ordita, per una caduta ottimale, morbida e rigorosa. Grazie alla sua elasticità e resistenza all’abrasione, Wool Satin è ideale per rivestire qualunque tipo di imbottito. La gamma cromatica comprende otto colori intensi, dai neutri con filati mélange alle tinte unite più brillanti.

PELLE FRAU® LEATHER - 2024 NEW LEATHERS

PELLE FRAU® KENTÉ

Le nouveau cuir Pelle Frau® Kenté, utilise l'impression numérique pour recréer sur le cuir le graphisme du tissu traditionnel africain Kenté, caractérisé par des motifs abstraits et des couleurs intenses, claires ou foncées, à forte signification symbolique, typiquement porté lors d'occasions formelles. Une variété que l'on retrouve dans les six nuances de cuir : Black, Red, Yellow, Purple, Blue et Green. Ozwald Boateng a réinterprété le motif textile spécifiquement pour ce revêtement en cuir, qui acquiert une intensité particulière grâce au processus d'impression innovant et aux couleurs vives. La bibliothèque Ren, le bureau Peek-a-Book et les fauteuils Ginger et Ginger Ale entrent dans la collection Boateng avec ce nouveau revêtement.

PELLE FRAU® NEST IMPACT LESS

Riche, solide, solide, mais incroyablement doux et soyeux au toucher, Pelle Frau® Nest Impact Less devient Impact Less, ce qui signifie tanné sans chrome et grâce à un processus innovant qui réduit l'utilisation de l'eau et des produits chimiques et utilise des sources d'énergie 100% renouvelables. Un processus qui, en plus d'être plus respectueux de l'environnement, améliore les qualités intrinsèques du cuir. Pelle Frau® Nest semble en effet plus doux au toucher, grâce à une main plus pleine et plus ronde. La plus grande tridimensionnalité et la soie de la surface sont rehaussées par la finition brillante et homogène. La palette de couleurs se renouvelle également, ajoutant à douze nuances existantes, huit nouvelles couleurs intenses et lumineuses.

PELLE FRAU® MOTIF KNITS

Un effet tactile et visuel particulièrement intéressant caractérise Pelle Frau® Motif Knits, un revêtement créé grâce à un processus d'impression 3D innovant qui simule un motif de tissage en relief ("twill"), également utilisé dans l'impression sur tissu, évoquant le monde de l'osier et de la vannerie. Pelle Frau® Motif Knits, obtenu à partir d'un processus d'impression numérique à chaud, s'inspire du monde de la mode pour reproduire un motif similaire au tissage, avec un effet tridimensionnel extrêmement contemporain seul ou combiné avec du cuir lisse.

POLTRONA FRAU FABRICS - 2024 NEW FABRICS

HARUKA

Haruka est le tissu bouclé réalisé grâce à un filage large et discontinu sur une toile de lin naturelle non blanchie. Le résultat est un matériau texturé et tridimensionnel. Irrégulière dans son artisanat et riche en texture, la toile Haruka est conçue pour habiller les produits avec des sensations visuelles et tactiles riches et superposées, rappelant le monde de la mode et de la haute couture.

KALAHARI

L'irrégularité caractéristique des fibres confère à Kalahari une texture particulière et une apparence flamboyante. L'entrelacement de la trame et de la chaîne crée un léger relief, semblable à un grain de riz, qui anime l'aspect de ce tissu faux fil-à-fil uni et donne à la surface un aspect tridimensionnel, rehaussé par une légère brillance. Kalahari est disponible dans une gamme chromatique de dix couleurs.

SURI

Aussi doux et tendre qu'un ourson, le tissu Suri est composé de fils de diverses natures, dont la vedette est une bouclette d'alpaga substantielle et précieuse. Ce matériau précieux, originaire du Pérou et filé en Italie, donne naissance à un bouclé doux, texturé et raffiné. Idéal en association avec des cuirs, le Suri est proposé dans le classique Beige naturel ainsi que dans les nouvelles nuances de Bleu Ciel et de Mogano.

WOOL SATIN

Le Wool Satin a une main extrêmement agréable, douce et fraîche au toucher. Il est obtenu à partir de satin de laine mérinos finement tissé, pour une chute optimale, douce et rigoureuse. Grâce à son élasticité et à sa résistance à l'abrasion, le Wool Satin est idéal pour recouvrir tout type de rembourrage. La gamme de couleurs comprend huit couleurs intenses, des tons neutres avec des fils mélangés aux teintes unies plus vives.

PELLE FRAU® LEATHER - 2024 NEW LEATHERS

PELLE FRAU® KENTÉ

最后是新款 Pelle Frau® Kenté，采用了数字印花技术，在皮革上重现了非洲传统 Kenté 织物的图案，这种织物的特点是图案抽象、色彩浓烈、明暗交错，具有强烈的象征意义，通常在正式场合穿着。多种变化存在于皮革的六种色调中：黑色、红色、黄色、紫色、蓝色和绿色。Ozwald Boateng 专门在这款皮革套面上重新诠释了织物图案，创新的印花工艺和鲜艳的色彩使该产品更具张力。Ren 书柜、Peek-a-Book 书桌以及 Ginger 和 Ginger Ale 扶手椅都采用了这种新的套面材料，从而加入了 Boateng 系列。

PELLE FRAU® NEST IMPACT LESS

丰富，坚固，结实，但触感柔软丝滑，Pelle Frau® Nest Impact Less成为Impact Less，意味着不含铬的鞣制，通过创新工艺减少水和化学品的使用，并使用100%可再生资源。这一工艺不仅更环保，还提升了皮革的内在品质。Pelle Frau® Nest触感更软，手感更饱满圆润。表面的立体感和丝滑感通过闪亮均匀的光泽得到增强。配色板也得到更新，增加了十二种现有色彩，以及八种新的鲜艳色彩。

PELLE FRAU® MOTIF KNITS

Pelle Frau® Motif Knits具有特别引人注目的触觉和视觉效果， 这是通过一种创新的3D打印工艺制成的覆盖物，模拟了一种凸起的编织图案（“twill”）， 也用于面料印花，唤起了柳条和篮织品的世界。

Pelle Frau® Motif Knits采用热数字打印工艺制成，灵感来自时尚界，以再现类似编织的图案，具有极具当代感的三维效果，无论是单独使用还是与光滑的皮革结合使用。

POLTRONA FRAU FABRICS - 2024 NEW FABRICS

HARUKA

Haruka是通过在简单、未漂白的亚麻画布上进行广泛而不连续的纺织而制成的布克雷织物。结果是一种有纹理、立体外观的材料。Haruka织物在工艺上不规则，质地丰富，旨在用丰富、层次分明的视觉和触觉感觉来装饰产品，让人联想到时尚和高级定制的世界。

KALAHARI

纤维的特征不规则性赋予了Kalahari一种独特的质感和火焰般的外观。经纬线的编织形成了类似米粒般的小凸起，为这种仿真纱线织物增添了活力，并赋予表面立体感，进一步由轻微光泽提升。Kalahari有十种颜色可供选择。

SURI

Suri织物柔软而温柔，就像一个泰迪熊，由各种各样的纱线组成，其中主演是厚实而珍贵的秘鲁羊驼卷曲毛线。这种珍贵的材料源自秘鲁，在意大利纺制，赋予了织物柔软、有质感和精致的卷曲效果。与皮革搭配时最理想，Suri提供经典的自然米色以及新推出的天蓝色和红木色。

WOOL SATIN

Wool Satin手感极为舒适，柔软且凉爽。它由密织的精细美利奴羊毛织制成，提供最佳的柔软且坚固的下垂效果。由于其弹性和耐磨性，Wool Satin非常适合用于覆盖任何类型的填充物。色彩范围包括八种浓郁的颜色，从混纺纱线的中性色调到更明亮的纯色。

Kenté leather

Kenté — Black

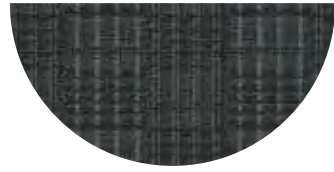

Kenté — Blue



Kenté — Green



Kenté — Purple

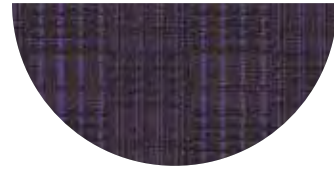

Kenté — Red



Kenté — Yellow

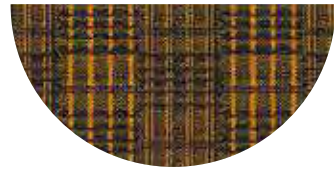

Motif Knits leather

Motif Knits —
Deep Lavender



Motif Knits — Sesame



Motif Knits — Paprika



Motif Knits — Grey Salt



Nest leather

Nest — Quarzo Rosa



Nest — Pietra Sole

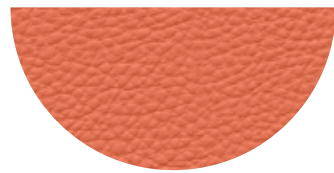

Nest — Cinabro

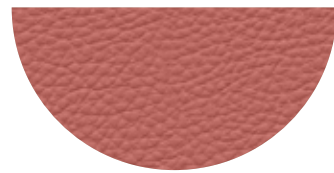

Nest — Alamandino



Nest — Adularia



Nest — Giada Imperiale

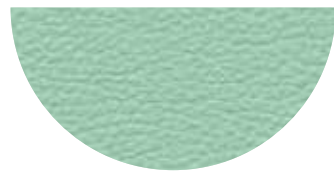

Nest — Zircone

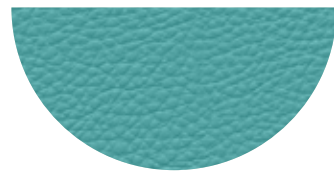

Nest — Azzurrite



Haruka

Haruka — Pollen



Haruka — Whity



Haruka — Peach Brown



Haruka — Dusty Blue



Kalahari

Kalahari — Cocoa

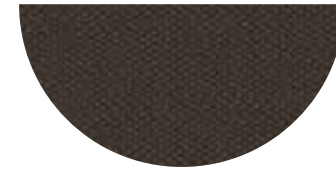

Kalahari — Coral



Kalahari — Forest



Kalahari — Gold



Kalahari — Greige

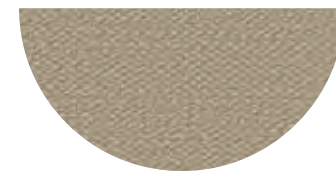

Kalahari — Ivory



Kalahari — Melange Grey



Kalahari — Pistachio

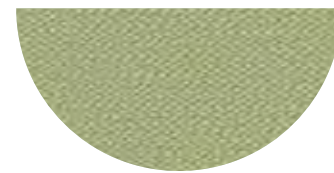

Kalahari — Royal Blue



Kalahari — Salmon

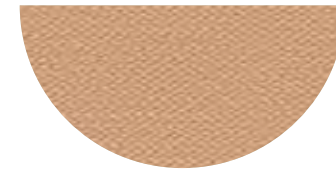

Suri

Suri — Mahogany



Suri — Beige

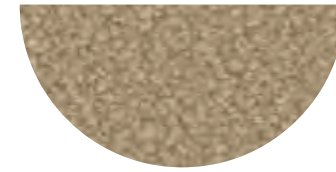

Suri — Azul



Wool Satin

Wool Satin — Cayenna



Wool Satin — Dark Marengo



Wool Satin — Honey



Wool Satin — Light Marengo



Wool Satin — Nougat



Wool Satin — Peacock



Wool Satin — Taupe



Wool Satin — Tobacco



Translations

- 226 [Italian Translation](#)
- 228 [French Translation](#)
- 230 [Chinese Translation](#)

Tecnical Drawings

- 232 [Archibald Bed](#)
- 233 [Archibald Dining Chair Large](#)
- 233 [Archibald Task Chair](#)
- 234 [Brera 90th Anniversary Edition](#)
- 235 [Bretagne Gran Comfort](#)
- 237 [DUO Chair/Small armchair](#)
- 238 [Ginger & Ginger Ale | Oswald Boateng x Poltrona Frau](#)
- 242 [Happy Jack](#)
- 246 [Martha | Oswald Boateng x Poltrona Frau](#)
- 246 [Nice](#)
- 247 [Nymph](#)
- 246 [Office Collection](#)
- 249 [Parka](#)
- 251 [Peek-a-Book | Oswald Boateng x Poltrona Frau](#)
- 251 [Peek-a-Book Large](#)
- 252 [Pet Collection](#)
- 253 [Pillow Cinema](#)
- 255 [Ren Bookcase | Oswald Boateng x Poltrona Frau](#)
- 256 [Squash](#)
- 257 [Squash Mirror](#)
- 258 [Squash Rug](#)
- 258 [Stock'n Roll](#)
- 259 [Tableau](#)
- 259 [Vanity Fair XC Imagine Edition](#)
- 260 [Tableware](#)
- 262 [Water illusion](#)

Il cuscino è in due versioni, Medium e Large. È disponibile in colore Beige: Tessuto Beady (67% viscosa, 33% cotone). Il cuscino è facilmente sfoderabile e utilizzabile sia con la cuccia Dog Bed che da solo.

TABLEAU <p>Simona Cremascoli</p> <p>La nuova versione di Tableau, il pannello decorativo da parete ideato da Simona Cremascoli, è nei colori della Pelle Frau® Nest presentati quest'anno. Tinte intense e luminose compongono un quadro dalla grafica geometrica ed elementare, che evoca gli esercizi cromatici del Bauhaus.</p>
--

FR
Imagine est la capacité de penser au nouveau et de donner forme aux désirs. Imagine, le thème de la nouvelle collection Poltrona Frau, est une réflexion profonde sur le pouvoir de la liberté créative ; une attitude qui permet de renouveler le passé, d’interpréter le présent et de se projeter dans l’avenir.
Quelle place laissons-nous à l’imagination dans le monde d’aujourd’hui ? Poltrona Frau, à travers sa nouvelle collection Imagine, répond à cette question en explorant et en nous impliquant tous dans l’expérience de sa présentation à Milan, à l’occasion du Salon du meuble 2024 (« Salone Internazionale del Mobile »). Dans la peinture, dans la littérature, dans la musique (la merveilleuse chanson de John Lennon vient immédiatement à l’esprit), l’imagination a toujours joué un rôle central et reconnu. Mais celle-ci risque de rester confinée dans l’enceinte, pourtant vaste, de l’expression artistique individuelle. Au contraire, le défi de la Collection Imagine est précisément de transporter l’imagination dans notre contexte quotidien, de l’utiliser comme un outil pour transformer la réalité en fonction de nos besoins et de nos désirs.

Le mot « imagination » traduit le grec « eikasia », c’est-à-dire la capacité de penser en dehors des processus logiques. Une capacité que Poltrona Frau possède dans son ADN depuis l’époque de Renzo Frau et de ses intuitions techniques, esthétiques et commerciales. Et qu’elle continue de décliner de manière toujours nouvelle à travers son histoire, son catalogue et dans les différents volets de la collection qui, cette année, voit de nombreux nouveaux designers appelés à collaborer aux différents projets.

BRETAGNE GRAN COMFORT
Poltrona Frau Style & Design Centre

Bretagne, l’un des canapés les plus connus de Poltrona Frau, est maintenant rejoint par une nouvelle version : Bretagne Gran Comfort, dont l’ergonomie, les proportions et le revêtement ont été repensés. Le restyling se caractérise par un rembourrage plus abondant et plus structuré, avec des lignes horizontales et enveloppantes qui remontent jusqu’à la tête, pour rendre le canapé encore plus confortable et favoriser une convivialité détendue et spontanée. Les pieds et la structure caractéristique de la cuve qui distingue le modèle Bretagne restent inchangés. Ce qui a changé, en revanche, c’est le rembourrage interne, aux dimensions plus généreuses et plus accueillantes : les coussins du dossier ont été augmentés en taille et en rembourrage, pour servir de soutien lombaire et se relever pour accueillir la tête, tandis que les coussins de l’assise sont plus structurés, avec une ligne élégante accentuée par des coutures qui, en plus de leur fonction esthétique, contribuent à maintenir leur forme dans le temps.Le design innovant de Bretagne Gran Comfort est souligné par le revêtement qui, sur les parties structurelles (base, côtés

et dossier), peut également être réalisé dans le tout nouveau cuir Pelle Frau® Motif Knits en quatre couleurs différentes : Deep Lavender, Sesame, Grey Salt et Paprika. Ce cuir nubuck est imprimé à chaud, recréant l’effet similaire de fils entrecroisés (« twill ») également utilisée dans la fabrication de tissus. L’effet tactile et visuel, très tridimensionnel, crée un beau jeu de contrastes avec le cuir lisse ou le tissu d’ameublement.

HAPPY JACK
Ludovica Serafini + Roberto Palomba

Conçue par le duo Ludovica Serafini + Roberto Palomba, Happy Jack doit son nom à son accoudoir incurvé caractéristique en forme de sourire. La collection évolue avec un ensemble d’éléments qui, tout en conservant les mêmes caractéristiques formelles, se distinguent par une ligne plus incurvée et enveloppante, porteuse d’un concept de convivialité plus facile et intime. Parmi les nouveautés, citons le Canapé d’angle à 45°, disponible avec accoudoir droit ou gauche ou sans extrémité, le Pouf monté sur les mêmes pieds que le canapé, aussi en version Large, et la Chaise Longue inclinable avec accoudoir droit ou gauche ou même sans accoudoirs. Avec les nouveaux modules, les configurations possibles se multiplient, s’adaptant à des espaces et des exigences différents. Happy Jack devient ainsi un meuble jouant un rôle encore plus prépondérant dans le living de Poltrona Frau, grâce à la variété des solutions, à la richesse des détails et à son élégance formelle. Les caractéristiques techniques d’Happy Jack se rattachent à celles des produits de la collection déjà en catalogue. Le revêtement peut être entièrement en cuir Pelle Frau®, en cuir Pelle Frau® assorti au tissu, en Cuir Saddle Extra pour la structure et en cuir Pelle Frau® ou tissu pour les coussins. Le siège inclinable est muni d’un mécanisme électrique à l’intérieur du coussin d’assise, qui permet de le soulever avec différents angles d’ouverture, afin de modifier l’inclinaison du dos et des jambes de la personne allongée. Le mouvement est facile à régler via télécommande sans fil. Sur les sièges inclinables, le rembourrage et les coutures diffèrent des modules et des canapés sans mécanisme car ceux-ci sont conçus afin d’être fonctionnels au mouvement.

OZWALD BOATENG X POLTRONA FRAU

Martha
Roberto Lazzeroni
Le revêtement utilisé pour le fauteuil Martha est Velvet Fabric Tribal. Sur un fond monochrome teint en quatre couleurs vives (Red, Green, Purple et Yellow), le motif Tribal noir est imprimé numériquement. La finition spéciale confère au velours un toucher doux et une agréable sensation dans la main. Le fauteuil Martha est également présenté aujourd’hui sous cette nouvelle forme, qui ajoute une touche dandy et sophistiquée à l’unes des chaises les plus appréciées du catalogue Poltrona Frau. La nouvelle version présente donc un intérieur en velours, disponible en Red, Purple, Green ou Yellow, et un revêtement extérieur en Cuio Saddle Extra, dans les couleurs figurant actuellement sur la liste des prix.

Ren Bookcase
Neri&Hu
L’édition spéciale de la bibliothèque Ren, dans les versions Low, High et Freestanding Bookcase, a des étagères revêtues de cuir Pelle Frau® Kenté. Les coutures sont de la même couleur.

Peek-a-book
Roberto Lazzeroni
Même coloris que le cuir Pelle Frau® Kenté

pour le plateau en cuir du bureau Peek-a-Book, qui peut être équipé de divers accessoires, tels qu’un porte-stylo, une prise électrique et un cache-câble conique.

Ginger Ale
Roberto Lazzeroni
Les deux petits fauteuils Ginger et Ginger Ale, dans la nouvelle version Boateng, ont une structure extérieure en cuir Pelle Frau® Kenté en six couleurs. L’intérieur de la structure est en cuir Pelle Frau® SC. La couleur du fil de couture est assortie au cuir sur lequel il est appliqué. Les deux petits fauteuils sont disponibles dans toutes les variantes de la liste de prix, c’est-à-dire fauteuil fixe ou pivotant pour Ginger, tandis que Ginger Ale peut être doté d’un piètement à quatre pieds en bois ou en métal, fauteuil à quatre branches, avec colonne en métal, fauteuil à cinq branches avec roulettes, également en métal.

PARKA
Draga & Aurel
Poltrona Frau présente sa nouvelle série de canapés modulaires Parka. Une collection qui marque le début d’une collaboration avec le duo créatif Draga & Aurel. Parka rend hommage à un vêtement désormais classique du streetwear des années 1990, typique de la culture grunge américaine et devenu par la suite le symbole de toute une génération. Tout comme ce vêtement légendaire, Parka est un canapé passe-partout, facile à combiner et extrêmement polyvalent, malgré sa forte personnalité. Les lignes douces et les volumes généreux rembourrés jusqu’au sol promettent confort et détente. La forme elliptique particulière du dossier, qui s’incline pour devenir un accoudoir puis un siège sans rupture, crée un espace concave ou convexe à la fois audacieux et accueillant, capable de s’adapter facilement à différents styles. La collection Parka comprend des éléments modulaires : un fauteuil concave ou convexe sans accoudoirs ou avec un accoudoir terminal, ce dernier également dans une version maxi, toujours à gauche ou à droite. Le revêtement peut être entièrement en cuir Pelle Frau®, dans les différents types présents dans le catalogue, ou dans la combinaison cuir + tissu. Dans ce cas, le premier revêtement est appliqué à la structure extérieure, tandis que le second est appliqué à l’assise, au dossier et à l’accoudoir. Les coutures sont de la même couleur.

SQUASH
Faye Toogood
Douceur, audace et plaisir en une seule collection : Squash, créée par l’artiste britannique Faye Toogood, séduit par sa nonchalance irrévérencieuse, dès son nom, ludique et sensuelle, reflétant une approche douce et sculpturale du design. La collection est confortable et accueillante dès le premier coup d’œil. Des formes exubérantes et audacieuses, mais douces et chaleureuses, dialoguent avec différents matériaux, souples ou rigides. Les lignes organiques et les rembourrages renversent la nature statique du mobilier formel. Des éléments typiques du folklore anglais sont réinterprétés et mélangés à des suggestions des années 1970. Squash propose une idée de l’élégance facile et moderne, composée d’objets uniques qui se présentent bien seuls, ensemble ou combinés avec d’autres meubles.

Poltrona Squash
Le fauteuil Squash, aux formes généreuses et chaleureuses, est constitué d’une structure rigide en Polimex® sur laquelle est posé le coussin large et douillet, recouvert de cuir Pelle Frau® ou de la combinaison cuir-tis-

su, entièrement déhoussable. La structure et les pieds sont légèrement rembourrés, ce qui les rend agréables au toucher. Les pieds de la base sont recouverts de cuir. Le coussin d’assise et les accoudoirs sont en ouate de polyester et en mousse de polyuréthane à densité différenciée pour plus de confort. Le pied du siège est en contreplaqué de bouleau. Les combinaisons de couleurs recommandées par le designer pour le fauteuil Squash sont Cream, Sage, Blue et Brown.

Ottoman Squash
Complément idéal du fauteuil de la même collection, le confortable pouf Squash a une structure en contreplaqué de bouleau et est revêtu de cuir. Les pieds sont légèrement rembourrés de mousse de polyuréthane, ce qui les rend agréables au toucher. Le coussin du pouf est déhoussable, rembourré de mousse de polyuréthane et d’ouate de polyester, et peut être entièrement revêtu de tissu ou de cuir Pelle Frau®. Comme pour le fauteuil, les combinaisons recommandées par le designer sont Cream, Sage, Blue et Brown.

Squash Table
La table basse Squash présente un design audacieux et original, caractérisé par deux blocs de bois laqués espacés d’un coussin central revêtu de cuir Pelle Frau® ColorSphere dans une couleur assortie à celle des blocs. La table basse est disponible en quatre combinaisons de couleurs seulement : Cream, Sage, Blue et Brown. En option, un petit tapis de protection en cuir Pelle Frau® ColorSphere est disponible, assorti au coussin central de la table basse.

Squash Rug
Le tapis Squash, qui fait partie de la collection du même nom, présente un motif en damier inspiré des anciennes chaises anglaises en patchwork. Chaque carré a été peint à la main et l’œuvre d’art a été traduite en tissu en utilisant la technique traditionnelle du nouage berbère. Le tapis Squash est fabriqué à la main et est disponible en plusieurs tailles et couleurs. Les teintures et les fibres naturelles reproduisent le plus fidèlement possible la peinture à la main, tandis que le velours profond et les fils flous évoquent l’aspect nuancé des coupes de pinceau. Tout en respectant des normes élevées en matière de développement durable.

Squash Long Mirror
Le miroir pleine longueur Squash est revêtu de cuir et reprend les lignes sinueuses et organiques de la collection dont il fait partie. Il se caractérise par le contraste entre un matériau rigide, le verre et les cadres courbes, doux et tactiles, recouverts de cuir Pelle Frau® ColorSphere. Le miroir longitudinal peut être fixé au mur ou rester debout grâce à un trépied qui peut être acheté séparément. Le miroir est disponible dans les couleurs SC 92 Garnet, SC 67 Clove et SC 254 Steel Blue.

Squash Long Mirror
Le miroir pleine longueur Squash est revêtu de cuir et reprend les lignes sinueuses et organiques de la collection dont il fait partie. Il se caractérise par le contraste entre un matériau rigide, le verre et les cadres courbes, doux et tactiles, recouverts de cuir Pelle Frau® ColorSphere. Le miroir mesure 1000×800 cm et est disponible dans les couleurs SC 92 Garnet, SC 67 Clove et SC 254 Steel Blue.

Squash Mirror
Le miroir mural Squash est revêtu de cuir et reprend les lignes sinueuses et organiques de la collection à laquelle il appartient. Il se caractérise par le contraste entre un matériau rigide, le verre et les cadres courbes, doux et tactiles, recouverts de cuir Pelle Frau® ColorSphere. Le miroir mesure 1000×800 cm et est disponible dans les couleurs SC 92 Garnet, SC 67 Clove et SC 254 Steel Blue.

Squash Pocket Mirror
Le miroir de poche Squash est revêtu de cuir et reprend les lignes sinueuses et organiques de la collection dont il fait partie. Il se caractérise par le contraste entre un matériau rigide, le

verre et les cadres courbes, doux et tactiles, recouverts de cuir Pelle Frau® ColorSphere. Miroir de voyage ou de poche. Le double miroir est enfermé dans un étui en cuir pliable. Ses dimensions sont de 8,5 × 8,5 cm (fermé) et de 17,9 × 8,5 cm (ouvert). Disponible dans les couleurs SC 92 Garnet, SC 67 Clove et SC 254 Steel Blue.

VANITY FAIR XC IMAGINE EDITION
Renzo Frau
Fornasetti x Poltrona Frau
Le fauteuil Vanity Fair XC Édition Imagine est proposé en édition limitée de 50 exemplaires, numérotés un par un et habillé de cuir Pelle Frau® embossé avec le motif Soleils et Nuages de Fornasetti. Chaque fauteuil est livré avec une pochette en cuir exclusive, un certificat d’authenticité signé et un porte-clés spécial en cuir Vanity Fair XC. La structure porteuse est réalisée en bois de hêtre massif vieilli. Le rembourrage est composé à la fois de crin végétal modelé à la main et de crin gommé, tandis que le coussin d’assise est en plumes d’oie, avec un insert en mousse de polyuréthane pour en maîtriser la forme dans le temps. L’assise, le dossier et les accoudoirs possèdent une suspension réalisée à partir de ressorts biconiques en acier attachés à la main et fixés sur des sangles en jute. Le dos et les joues du fauteuil sont agrémentés d’une rangée de petits clous habillés de cuir. Le revêtement est en cuir Pelle Frau® Impact Less, orné d’une impression numérique caractérisée par un effet légèrement gaufré. Une plaquette de couleur canon de fusil griffée du logo Fornasetti x Poltrona Frau® et portant le numéro de série est appliquée sur l’arrière du dossier.

ARCHIBALD
Jean-Marie Massaud
Archibald Large Dining Chair
Le petit fauteuil Large dining chair est déclinée dans une version aux proportions encore plus généreuses. L’assise large et le dossier plus haut enveloppent et soutiennent, donnant ainsi une sensation de confort extrême. La nouvelle chaise Archibald peut être revêtue de cuir ou de tissu. La version en cuir Pelle Frau® est enrichie de précieuses coutures contrastées qui rehaussent sa forme. Archibald Large Dining Chair est disponible avec le pied en métal peint par poudrage ou en titane.

Archibald Task Chair
Archibald Managerial et Archibald Executive apportent également une note d’élégance contemporaine à l’univers du home-office. Fruit d’une importante étude ergonomique, les nouveaux petits fauteuils Archibald sont conçus pour accompagner le corps dans tous ses mouvements et le soutenir correctement devant le bureau ou l’ordinateur. Les finitions métalliques vous permettent de personnaliser encore plus Archibald, en l’associant à tout type de mobilier. Archibald Managerial et Archibald Executive ont le pied en aluminium moulé sous pression avec un mécanisme pivotant qui permet de tourner le fauteuil à 360° et de le régler en hauteur. Le pied est disponible dans les finitions suivantes : aluminium poli et aluminium peint en noir, qui peut également être équipé de différents types de roulettes ou de glissières pivotantes. Les deux versions home-office de l’Archibald sont équipées des éléments suivants : réglage de la hauteur de l’assise au moyen d’un vérin à gaz ; réglage de l’inclinaison et de l’oscillation du dossier et de l’assise, avec possibilité de réglage partiel de la force d’oscillation au moyen d’un mécanisme qui permet au fauteuil de suivre le parcours du corps avec une extrême facilité ; rotation de 360° autour de l’axe vertical.

Archibald Bed
Pour la première fois, Archibald aborde l’argument couchage avec un lit qui réinterprète l’esprit de la collection dans une touche d’élégance raffinée. Une structure au profil doux et accueillant, enveloppée par une haute tête de lit en cuir qui l’englobe en s’inclinant vers le bas pour couvrir ses deux coins. Le jeu de plis verticaux du cuir et les surpiqûres de la même couleur sur le bord extérieur de la tête de lit ajoutent une touche luxueuse et sophistiquée à un lit en mesure de donner une sensation d’intimité et de chaleur malgré ses lignes importantes. Le lit Archibald est disponible en cinq tailles, en deux hauteurs à partir du sol et dans une version pratique avec rangement dissimulé. Le revêtement est entièrement en cuir Pelle Frau® ColorSphere® ou Nest, et le dossier est également disponible en version toile Jacquard Poltrona Frau, ce qui est utile lorsqu’il doit être placé contre le mur. Le modèle avec unité de rangement n’est disponible que dans la version pouvant accueillir un matelas de 170 cm. L’accès au meuble de rangement s’effectue en soulevant le plan de repos à l’aide de deux poignées en cuir qui actionnent un dispositif à vérins à gaz, à simple ou double ouverture.

DUO CHAIR/SMALL ARMCHAIR
Roberto Lazzeroni
La collaboration entre Ceccotti Collezioni et Poltrona Frau, qui a débuté en 2023 avec le lancement de la collection DUO, se poursuit aujourd’hui avec l’élargissement de l’offre. Cette année, l’accent est mis sur la salle à manger de la maison, avec de nouvelles propositions signées à nouveau par le designer Roberto Lazzeroni. Parmi les nouveautés, voici la nouvelle chaise rembourrée, avec ou sans accoudoirs, associée à la table en quatre variantes créées par Ceccotti Collezioni. La gamme DUO est complétée par la banquette, dans une variante dimensionnelle, et par le buffet, dans une nouvelle finition pour le revêtement extérieur. La chaise Duo, fabriquée par Poltrona Frau, est un siège rembourré aux lignes sinueuses et chaleureuses. Tout dans ce fauteuil communique une sensation de douceur et en même temps de dynamisme : les pieds arrière inclinés donnent de l’élan à la chaise à haut dossier ou au petit fauteuil qui s’élargit latéralement en deux chaleureuses « oreilles ». L’assise convexe joue avec la légère concavité du dossier, en déplaçant les volumes. Le riche rembourrage, entièrement recouvert de tissu ou de cuir Pelle Frau®, ajoute un confort supplémentaire et invite à la détente et à la conversation. Les pieds en frêne massif peuvent être teintés Wengé ou Moka, teintés ou laqués RAL de la couleur de l’échantillon fourni par le client.

NICE
Poltrona Frau Style & Design Centre
La chaise Nice doit son succès à son design ergonomique et enveloppant. Les deux coques du dossier et de la structure se plient et se superposent comme deux feuilles de papier pliées, créant un espace dans le dos du dossier qui devient un signe distinctif et reconnaissable. Le revêtement souple en tissu ou en cuir Pelle Frau® souligne les formes confortables et accueillantes du fauteuil, qui peut également être revêtu de cuir sur l’extérieur du dossier. L’extension de la collection avec un nouveau pied en frêne massif a été créée pour offrir un choix plus large et pour faciliter l’association avec d’autres tables en bois du catalogue. La base et les pieds en frêne massif peuvent être en finition Naturale (naturel) ou teintés Wengé, Moka, ou encore teintés ou laqués RAL de la couleur de l’échantillon fourni par le client.

PEEK-A-BOOK LARGE
Roberto Lazzeroni
Peek-a-Book, le bureau conçu en 2021 par Roberto Lazzeroni pour la Collection Imagine 2024, revient dans une version plus grande, avec un plateau plus large d’environ 30 cm par rapport à la version actuelle. Le bureau Peek-a-Book se caractérise par un plateau façonné en panneaux de contreplaqué de peuplier contrecollés avec du MDF. La façade incurvée, en mousse de polyuréthane moulée, se replie pour former le fond du bureau et dissimuler à l’intérieur des tiroirs et des compartiments à accessoires. L’effet visuel est celui d’un livre précieux relié en cuir Pelle Frau®, symbolisant la fonction même de l’objet : le bureau est en effet le lieu où sont produites et rassemblées les idées, les pensées, les souvenirs ; la partie la plus intime et la plus personnelle de ceux qui y étudient ou y travaillent. Le bureau Peek-a-Book se compose d’un piètement en frêne massif teinté Wengé ou teinté Moka avec un profil de section triangulaire. La façade des tiroirs est en MDF recouvert de cuir Pelle Frau® assorti au revêtement du plateau façonné en panneaux de contreplaqué de peuplier contrecollés en MDF. Le revêtement du plateau, de la façade des tiroirs, des parois latérales et des portes d’accès aux compartiments arrière est en cuir Pelle Frau® ColorSphere®.

Derrière les deux tiroirs frontaux se trouvent des compartiments conçus pour le passage de câbles, accessibles par des portes latérales. Le bureau est disponible avec les mêmes options que la version actuellement dans la liste de prix. Seul le porte-stylo est fourni avec une taille différente, adaptée à la nouvelle largeur des tiroirs : Porte-stylos version Large, revêtu de cuir Pelle Frau® ColorSphere®.

BRERA
Pour célébrer son 90e anniversaire, le légendaire banc conçu par Guglielmo Ulrich et réédité par Poltrona Frau fait son grand retour dans une édition multicolore spéciale pensée pour cette occasion.Le tissage de l’assise est constitué uniquement de bandes de couleur cuir, confectionnées en SC 66 India, qui se dénouent sur le côté long du banc pour ne pas interrompre son profil et maintenir le côté épuré des formes du design, en respectant l’équilibre entre la rigueur formelle et l’éclectisme chromatique typique de l’œuvre de Guglielmo Ulrich. La chaîne, en revanche, se caractérise par une succession raffinée de tons chauds et froids, toujours issus de l’univers de Pelle Frau® ColorSphere® : Darsena, Bardiglio, Cocciopesto, Avorio et Garnet, qui instaurent un dialogue harmonieux entre eux, dessinant un motif géométrique et texturé extrêmement actuel. La structure et les deux supports, effilés et légers, sont en frêne massif avec une finition Wengé, également disponible en Moka à la demande. L’édition spéciale Brera 90th Anniversary peut être commandée de l’ouverture du Salon du Meuble au 31 décembre 2024. Elle s’agrémente d’une plaquette en métal apposée sur la partie intérieure. Une nouvelle version unie, toujours en cuir Pelle Frau® SC, est lancée aux côtés de l’édition 90th Anniversary, venant s’ajouter à celle en Cuir Saddle Extra déjà disponible en catalogue.

OFFICE COLLECTION
Giobagnara x Poltrona Frau
Toujours en co-branding avec Giobagnara, la Collection Office : des accessoires conçus pour rendre le bureau ou le poste de travail plus agréable. Porte-stylos ou classeur pour feuilles A4, tapis de souris, sous-main, corbeille à papier, porte-lettres, porte-ordinateur portable… tous revêtus de cuir Pelle Frau®, toujours dans les coloris India ou Quarzo Fumé et soigneusement finis avec des surpiqûres et les plus petits détails.

WATER ILLUSION
Assia Karagiozova
Water Illusion, la collection de vases d’Assia Karagiozova, s’enrichit d’une nouvelle teinte dans les tons de vert, Emerald Whispers. Créés par des maîtres verriers italiens selon la technique du verre coulé à la main, les vases de la créatrice bulgare, fabriqués dans des verreries vénitiennees, ont des formes non reproductibles, ce qui rend chaque pièce unique. Les « pétales » de verre, irréguliers et ondulés, parlent le langage des vagues et ont une épaisseur matérielle importante. La double texture à l’intérieur rappelle, au contact de la lumière, l’effet de l’eau sur une surface. Les quatre modèles sculpturaux, deux vases et deux bols de deux tailles différentes, se développent à la frontière entre l’art et le design.

qui invite à l’ouvrir. La table de chevet Stock’n Roll est dotée d’une structure portante et d’une porte en multiplis cintré de hêtre et en hêtre massif. Le revêtement est en cuir Pelle Frau®, avec des surpiqûres ton sur ton. Le meuble de rangement est disponible avec une ouverture à gauche ou à droite. D’un geste, la porte, équipée d’un petit plateau interne, s’ouvre pour révéler un compartiment doté d’une étagère pour ranger des objets. La tablette et le plateau sont en multiplis de bouleau et recouverts d’un revêtement assorti à la surface extérieure. Le plateau peut être revêtu de cuir Pelle Frau® assorti aux surfaces intérieures et extérieures, ou de marbre précieux semi-brillant.

BEAUTILITIES
L’extraordinaire au quotidien.

Les nouveaux Beautilities de Poltrona Frau : de petits objets et accessoires pour embellir notre vie quotidienne. Le volet Imagine Well-Being regroupe toutes les collections Beautilities, c’est-à-dire les nombreux objets et compléments à usage quotidien créés pour embellir et rendre plus agréables les différents moments de notre vie dans tous les environnements et toutes les situations : la table, le bureau, les espaces extérieurs ou la relation avec les animaux de compagnie. Des petits luxes finis dans les moindres détails qui contribuent à nous faire sentir bien, à nous donner des sensations positives chaque fois que nous les regardons, que nous les touchons ou que nous les traversons.

TABLEWARE COLLECTION
Giobagnara x Poltrona Frau
Le plaisir de recevoir autour d’une table bien dressée est multiplié par les accessoires de la ligne Tableware en co-branding avec Giobagnara : des ensembles de plateaux ronds ou rectangulaires, sous-verres, assiettes, ronds de serviette, rafraîchisseur de bouteilles, panier à champagne avec son support et sets de table ajoutent une touche raffinée et précieuse aux dîners les plus simples. Le revêtement est en cuir souple Pelle Frau®, dans les couleurs India ou Quarzo Fumé.

OFFICE COLLECTION
Giobagnara x Poltrona Frau
Toujours en co-branding avec Giobagnara, la Collection Office : des accessoires conçus pour rendre le bureau ou le poste de travail plus agréable. Porte-stylos ou classeur pour feuilles A4, tapis de souris, sous-main, corbeille à papier, porte-lettres, porte-ordinateur portable… tous revêtus de cuir Pelle Frau®, toujours dans les coloris India ou Quarzo Fumé et soigneusement finis avec des surpiqûres et les plus petits détails.

WATER ILLUSION
Assia Karagiozova
Water Illusion, la collection de vases d’Assia Karagiozova, s’enrichit d’une nouvelle teinte dans les tons de vert, Emerald Whispers. Créés par des maîtres verriers italiens selon la technique du verre coulé à la main, les vases de la créatrice bulgare, fabriqués dans des verreries vénitiennees, ont des formes non reproductibles, ce qui rend chaque pièce unique. Les « pétales » de verre, irréguliers et ondulés, parlent le langage des vagues et ont une épaisseur matérielle importante. La double texture à l’intérieur rappelle, au contact de la lumière, l’effet de l’eau sur une surface. Les quatre modèles sculpturaux, deux vases et deux bols de deux tailles différentes, se développent à la frontière entre l’art et le design.

PET COLLECTION

Poltrona Frau Style & Design Centre

La gamme s'enrichit également de la Col­lection Pet, conçue par le Poltrona Frau Style & Design Centre. La laisse réglable, réalisée en ruban de tissu avec renfort anti-déchirure, est dotée d'une poignée en cuir Pelle Frau® disponible dans les couleurs Ume, associée à un ruban bordeaux et jaune ; Cypress, associée à un ruban vert et camel ; et India, associée à un ruban camel et vert. Les accessoires de finition sont en laiton galvanisé, le mousqueton est en nickel poli et le médaillon du logo est en zamak moulé sous pression avec une finition en nickel poli. Deux tailles disponibles : Small et Medium. Le collier est composé d'un ruban tissé en jacquard avec des boucles en cuir Pelle Frau® dans les couleurs Ume, Cypress et India, dans les mêmes combinaisons de tissus que la laisse. Il est doté d'une boucle fixe et d'une boucle mobile avec serrure, ainsi que d'un anneau en forme de D pour attacher la laisse. Il est disponible en quatre tailles différentes, de Extra Small à Large. Le harnais, avec sangles de poitrine et de poitrail réglables, est également disponible en quatre tailles et est fabriqué dans les mêmes matériaux et avec les mêmes finitions que le collier et la laisse. Les parties métalliques sont en laiton galvanisé au nickel poli. La gabelle est fabriquée en céramique émaillée sans plomb de couleur crème selon la technique des trois flammes. Elle peut être complétée par le tapis antidérapant, en similicuir et polyester, avec un motif décoratif imprimé. Le coussin existe en deux versions, Medium et Large. Il est disponible en beige : Tissu Beady (67 % viscose, 33 % coton). Le coussin est facilement déhoussable et peut être utilisé aussi bien avec le Dog Bed que seul.

TABLEAU

Simona Cremascoli

La nouvelle version de Tableau, le panneau mural décoratif conçu par Simona Cremascoli, est déclinée dans les couleurs de cuir Pelle Frau® Nest présentées cette année. Des couleurs intenses et lumineuses composent un tableau au graphisme géométrique et élémentaire, évoquant les exercices de couleurs du Bauhaus.

ZH

想象力是思考新生事物和塑造愿望的能力。想象,是Poltrona Frau新品系列的主题,也是对创作自由力量的深刻反思;是一种使我们能够更新过往、诠释当下并将自己投射到未来的态度。当今世界中,我们能为想象留下多少空间呢? Poltrona Frau以其全新系列Imagine在2024米兰国际家具展之际通过探索回答了这个问题,并让我们所有人都参与到了它在米兰的展示体验之中。在绘画、文学、音乐(约翰·列侬的美妙歌曲立即涌入脑海)中,想象力始终发挥着核心且公认的作用。然而,尽管范围很广,但仍有可能仅仅局限于个人艺术表达的挑战恰恰在于将想象力带入我们的日常环境,将其用作根据我们的需求和愿望来改变现实的工具。“想象力”一词译自希腊语“eikasias”，即超越逻辑过程的思考能力。自Renzo Frau时代以来,Poltrona Frau的DNA中就蕴藏着这种能力,同时它也具备技术、美学和商业方面的直觉。在其历史进程、产品目录和系列的不同集合中,公司都持续在向新的方式靠近,今年召集了许多新设计师进行多个项目的合作。

BRETAGNE GRAN COMFORT

Poltrona Frau Style & Design Centre

Bretagne是Poltrona Frau最为著名的沙发之一,现已推出一款全新版本: Bret-agne Gran Comfort,在人体工程学、比例和覆面方面都经过了重新考量。重新设计的特点在于它那丰满饱满且更具结构性的坐垫,具有迎合头部的水平包络线条,使沙发更加舒适且有助于轻松自然的社交。让Bretagne款型与众不同的支脚和特有浴缸式结构保持不变。有所改变的则是内部坐垫,尺寸更加宽敞且更加绵软:靠背垫的尺寸和填充物都有所增加,以充当腰垫并在上方支撑头部,而座垫则更具结构化,带有凸显优雅的缝线,具备美观功能的同时还有助于保持形状日久不变。Bretagne Gran Comfort的创新设计在结构部件(底座、侧面和靠背)覆面上得到了强调,覆面也可采用全新Pelle Frau® Motif Knits的四种不同颜色:深薰衣草色、芝麻色、灰蓝色、红椒粉色。这种牛巴戈皮经过热印花再有了类似于布艺制作中也使用的浮雕编织(“斜织法”)效果。触觉和视觉效果非常三维,与光面皮革或布料制成的坐垫部分形成鲜明对比。

HAPPY JACK

Ludovica Serafini + Roberto Palomba

由Ludovica Serafini + Roberto Palomba两人联袂设计,Happy Jack因其独具特色的微笑形弧度扶手而得名。该系列融合了一系列元素,在保持相同形状特征的同时以更加弯曲包络的线条独具一格,以此倡导一种更为轻松亲密的欢乐理念。新品包括:45°转角沙发,可配备右扶手或左扶手或是不带末端件;与沙发支脚设计相同的坐墩,大号版本也有提供;带右扶手或左扶手或是不带扶手的斜倚躺椅。全新模块允许您增加可能的配置,使其适应不同空间与需求。凭借解决方案的多样化、细节的丰富及其正式优雅,Happy Jack成为Poltrona Frau客厅中一款更加核心的家具产品。覆面完全采用Pelle Frau®皮革或是Pel-le Frau®皮革搭配布料,结构采用Cuoio Saddle Extra皮革,坐垫部分的材质为Pelle Frau® 皮革或布料。斜倚式座椅的坐垫内部装有一部电动机,使您能够以不同的打开角度将其升高,以改变躺卧者背部和腿部的倾斜度。座椅活动可通过无线遥控器轻松调整。在斜倚式座椅中,垫充填料和缝线不带电动机制的模块和沙发有所不同,因为这些垫充填料和缝线的设计旨在助力座椅的活动。

OZWALD BOATENG X POLTRONA FRAU

Martha Roberto Lazzeroni 标志性扶手椅 Poltrona Frau Martha使用的套面是天鹅绒面料 Velvet Fab-ric Wool Tribal。在四种鲜艳色彩(红、绿、紫、黄)的单色片染背景上,用数字技术印制了黑色的部落图案。经过特殊表面处理的天鹅绒质地柔软,手感舒适。Martha 小扶手椅如今也以这种全新的面貌呈现,为 Poltrona Frau 产品目录中最受欢迎的椅子之一增添了一丝俏丽而精致的气息。其新版本内侧采用红、紫、绿或黄色的天鹅绒,外壳采用 Cuoio Saddle Extra 皮革套面, 目前可提供产品目录中所示的颜色。

Ren Bookcase

Neri&Hu

特别版 Ren 书柜有矮款、高款和独立式书柜三种款式, 书架的隔层板采用 Pelle Frau® Kenté 皮革装饰。缝线为同色系的颜色。

Peek-a-book Roberto Lazzeroni Peek-a-Book 书桌的皮质桌面采用同色 Pelle Frau® Kenté 皮革, 可搭配各种配件, 如笔筒、电源插座和电缆盖。

Ginger Ale

Roberto Lazzeroni

两把小扶手椅 Ginger 和 Ginger Ale 在 Boateng 的新版中, 外壳的外侧采用了六种颜色的 Pelle Frau® Kenté 皮革套面。外壳内侧则采用 Pelle Frau® SC 皮革。缝线的颜色与皮革的颜色相匹配。这两款小扶手椅均有价目表中的所有款式可供选择, 即 Ginger 系列扶手椅有固定式和旋转式两种, 而 Ginger Ale 系列扶手椅则有木制或金属四脚底座、带金属柱的四辐扶手椅、带脚轮的五辐扶手椅(也是金属)可供选择。

PARKA Draga & Aurel

Poltrona Frau推出全新Parka组合模块沙发系列。该系列标志着与创意二人组 Draga & Aurel合作的开始。这个模块化座椅系统礼赞90年代街头服饰的经典服装,美国垃圾摇滚文化的典型后来成为整整一代人的象征。正如这款传奇服饰一样,Parka虽然个性鲜明,却是一款易于搭配且极其百搭的经典沙发。柔软的线条和宽大的及地填充体积保证了舒适度和休闲度。靠背独特的椭圆形取向向下倾斜为扶手,无缝连续的座椅创造出一个凹凸的空间,大胆温馨的同时能够轻松适应不同风格。Parka系列包含组合模块化元素:不带扶手或带末端扶手的凹形或凸形扶手椅,后者还有大号版本且扶手始终位于右侧或左侧。覆面可完全采用目录中提供的各种类型的Pelle Frau®皮革或是用皮革搭配布艺。这种情况下,第一种覆面应用于外部结构,而第二种覆面则应用于座椅、靠背和扶手。缝线全是同色系的。

SQUASH Faye Toogood Squash 集柔和、大胆和娱乐于一体的系列: Squash 由英国艺术家 Faye Toogood 设计, 其名字就以不羁的气质吸引眼球, 俏皮而感性, 体现了柔和而富有雕塑感的设计手法。该系列看一眼就让人感到舒适惬意。大胆奔放而又温和安心的造型与不同的软硬材料进行对话。有机的线条和柔软的填充颠覆了正式家具的静态特性。典型的英国民间元素被重新诠释, 并与 70 年代的迷人魅力相融合。Squash 提出了一种 轻松、现代的优雅理念, 其构成物件既可以单独或组合摆放, 也可以搭配其他家具一起摆放。

Poltrona Squash Squash 扶手椅外形大方舒适, 采用 Polimex® 制成的坚固支架结构, 上面铺有宽大柔软的坐垫, 套面可选择 Pel-le Frau® 真皮或可拆卸的真皮-布艺组

合。外壳和腿部包有轻薄的衬垫, 触感舒适。底座的腿部用皮革包裹。座垫和扶手填有聚酯絮棉和差异密度聚氨酯泡沫, 入座极为舒适。座椅底座采用桦木胶合板。设计师为 Squash 扶手椅推荐的颜色组合是乳白色、鼠尾草绿色、蓝色和棕色。

Ottoman Squash 舒适的 Squash 沙发凳是同系列扶手椅的理想补充, 其采用桦木胶合板框架和真皮套面装饰。腿部包有轻薄的聚氨酯泡沫衬垫, 触感舒适。沙发凳的软垫套面可拆卸, 里面填充有聚氨酯泡沫和聚酯絮棉, 可以全部用 Pelle Frau® 真皮或布艺装饰。与扶手椅一样, 设计师推荐的组合是乳白色、鼠尾草绿色、蓝色和棕色。

Squash Table Squash 茶几的设计大胆新颖, 在两块涂漆木中间穿插一个软垫, 软垫采用 Pelle Frau® ColorSphere 真皮套面, 颜色与木块相匹配。这款茶几只有四种颜色可供选择: 乳白色、鼠尾草绿色、蓝色和棕色。还可选配与茶几中央软垫相匹配的 Pelle Frau® ColorSphere 真皮桌垫。

Squash Rug Squash 地毯来自同名系列, 其棋盘格图案灵感来源于古老的英式拼花椅子。每个方块都是手绘设计, 然后用传统的柏柏尔编结技术将艺术画作转化成织物。Squash 地毯为手工制作, 有多种尺寸和颜色可供选择。天然染料和纤维尽可能忠实地再现了手绘作品, 而深绒和模糊的纱线则唤起了笔触的渐变外观。该产品完全遵守可持续发展的高标准。

Squash Mirror 全身镜: Squash 全身镜采用皮革装饰, 与其所属系列蜿蜒而有机的线条相呼应。其特点是硬质材料(玻璃)与柔软、触感好的Pelle Frau ColorSphere®真皮装饰弧形框架形成鲜明对比。镜子尺寸为 1000x800 cm, 有 SC 92 石榴红、SC 67 丁香色和 SC 254 钢蓝色可供选择。

镜子: Squash 壁挂镜采用皮革装饰, 与其所属系列蜿蜒而有机的线条相呼应。其特点是硬质材料(玻璃)与柔软、触感好的Pelle Frau ColorSphere®真皮装饰弧形框架形成鲜明对比。镜子尺寸为 1000x800 cm, 有 SC 92 石榴红、SC 67 丁香色和 SC 254 钢蓝色可供选择。袖珍镜子: Squash 袖珍镜采用皮革装饰, 与其所属系列蜿蜒而有机的线条相呼应。其特点是硬质材料(玻璃)与柔软、触感好的Pelle Frau ColorSphere®真皮装饰弧形框架形成鲜明对比。方便携带的旅行镜或袖珍镜。这款双面镜装在一个可折叠的皮革护套中。尺寸为 8.5 x 8.5 cm (闭合) 和 17.9 x 8.5 cm (打开)。有 SC 92 石榴红、SC 67 丁香色和 SC 254 钢蓝色可供选择。

VANITY FAIR XC IMAGINE EDITION

Renzo Frau

Fornasetti x Poltrona Frau

Vanity Fair XC Imagine Edition以限量发行50件的形式出品,每件作品单独编号并采用Pelle Frau®皮革包覆,同时印有Fornasetti的太阳和云朵图案。每把扶手椅在交付时都配有一个专属皮革手袋、一份由品牌签名的真品证书和一只特别的Vanity Fair XC皮革钥匙圈。支撑结构采用实心风干山毛榉制成。填充物采用手工成形植物毛和涂胶马鬃两种材料,座垫为鹅绒制成并带有发泡聚氨酯嵌件,以便在时间推移中保持不变。座椅、靠背和扶手均带有双锥形压缩钢弹簧,手工绑扎并固定在黄麻条带上。一排皮革包覆的小钉子点缀了扶手椅的背面和侧面。覆面材质为Pelle Frau® Im-pact Less,采用数字印刷并具有轻微凸起效果。靠背背面贴着带有Fornasetti x Poltrona Frau®徽标和序列号的青铜饰牌。

ARCHIBALD Jean-Marie Massaud

Archibald Large Dining Chair 这种效果便是引导三款全新座椅的相同原则:大号扶手餐椅倾向于一个比例更受欢迎的版本。宽大的座椅和更高的靠背能够起到拥抱和支撑的作用,给人一种极致舒适的感觉。新款Archibald座椅可采用皮革或布料进行包覆。采用Pelle Frau®皮革的版本饰有丰富的珍贵对比色缝线,这些缝线使其形状得以彰显。Archibald大号餐椅配有抛光粉末或钛粉末涂层的金属底座。

Archibald Task Chair Archibald Managerial和Archibald Executive也为家庭办公世界带来了具有当代感的优雅气息。全新Archibald小扶手椅是一项重要的人体工程学研究成果,其设计能够伴随身体的所有运动并在您坐在写字台前或电脑前时为您提供正确支撑作用。金属饰面能够更加个性化您的Archibald,并将其与任何类型的家具相组合。Archibald Managerial和Archibald Executive都有一个由压铸铝制成且配有旋转机制的底座,使小扶手椅可360°旋转并调节高度。底座提供两种可选饰面:亮光铝和黑色喷漆铝,可始终配备不同类型的轮子或旋转滑轨。Archibald的两种家庭办公版本均配备:气弹簧座椅高度调节装置;靠背和座椅的倾斜度与振动调节装置,可通过一种机制来偏化振动力,使扶手椅能够非常轻松地跟随身体的形状;绕其垂直轴的360°旋转装置。

Archibald Task Bed

Archibald首次出现在睡眠区,添入了一款以精致优雅的方式重释该系列之精神的床。床的结构具有柔软温馨的轮廓,包裹在高的皮革床头板中,同时床头板向下倾斜以覆盖两个角落。皮革的垂直褶皱和床头板外缘的同色系缝线之间那丰富的搭配为这款床凭添一丝奢华与精致,尽管这款床的线条非常鲜明,但这份奢华与精致仍能为人赋予一种亲密温暖的感觉。Archibald床提供五种尺寸、两种离地高度以及一款带有伸缩储物箱的实用型版本。覆面完全采用Pelle Frau® ColorSphe-re®或Nest材质,背面也采用Poltrona

Frau Jacquard帆布版本,靠墙置放时很有用。这款床的设计使其能够放置不同尺寸的床板架(固定型、手动型或电动型)和床垫。带储物箱的型号仅提供适合放置170厘米床垫的版本。使用两只皮革手柄提起床板架便可打开储物箱,手柄带有气弹簧激活装置,您可选择单开或双开运动。

DUO CHAIR/SMALL ARMCHAIR Roberto Lazzeroni Ceccotti Collezioni与Poltrona Frau之间的合作以DUO系列的推出而始于2023年,这项合作如今随着产品范围的扩展而延续。今年的聚焦点是住所的用餐区,全新提案依然由设计师Roberto Lazzeroni设计。新品中脱颖而出的是带有扶手或不带扶手的新款软包椅子,可搭配Ceccotti Collezioni设计的四个不同款式的桌子。完善了DUO系列的还有尺寸各异的长凳以及外部覆面采用全新饰面的储物箱。

由Poltrona Frau设计的Duo Chair,是一款带有软垫且线条蜿蜒包络的座椅。这款小扶手椅中的一切都传达出一种柔软感,同时又充满活力:倾斜的后支腿为高靠背的椅子或横向扩展为两只欢迎“耳朵”的小扶手椅赋予了生气。凸形座椅与靠背的轻微凹形相辅相成,使其体积更具动感。饱满的垫充填料完全由Pelle Frau®皮革或布料覆面,增加额外舒适度同时带来休闲互动的感觉。实心白蜡木支腿可采用鸡翅木色或摩卡色、原色或RAL漆面原色。

由Poltrona Frau设计的Duo Chair,是一款带有软垫且线条蜿蜒包络的座椅。这款小扶手椅中的一切都传达出一种柔软感,同时又充满活力:倾斜的后支腿为高靠背的椅子或横向扩展为两只欢迎“耳朵”的小扶手椅赋予了生气。凸形座椅与靠背的轻微凹形相辅相成,使其体积更具动感。饱满的垫充填料完全由Pelle Frau®皮革或布料覆面,增加额外舒适度同时带来休闲互动的感觉。实心白蜡木支腿可采用鸡翅木色或摩卡色、原色或RAL漆面原色。

NICE

Poltrona Frau Style & Design CentreNice 座椅的成功归功于其符合人体工程学的包络设计。靠背和主结构的两个外壳像两张折叠的床单一样弯曲并重叠,在靠背后部形成一个空隙,成为一个独具一格且具有高度辨识度的标志。采用Pelle Frau®皮革或布料制成的定制化柔软覆面彰显了扶手椅那舒适温馨的形状,靠背外部也可用皮革进行覆面。该系列以一款全新白蜡木实木底座而得以延展,旨在提供更为广泛的选择并方便搭配目录中的其他木桌。实心白蜡木底座和支腿可采用天然饰面或鸡翅木色、摩卡色、原色或RAL漆面原色。

PEEK-A-BOOK LARGE Roberto Lazzeroni Peek-a-Book,一款由Roberto Lazze-roni于2021年设计的写字台,它在2024 Imagine Collection系列中以一个较大版本重新回归,桌面比当前旧版本扩大了约30厘米。

Peek-a-Book写字台的特点在于它那采用杨木胶合板制成的桌面,桌面带有中密度纤维板制成的底面。弯曲的前板由模压聚氨酯泡沫制成,向下折叠后形成写字台的底板并将抽屉和配件隔层隐藏在内部。其视觉效果就像一本用Pelle Frau®装订而成的珍贵书籍,象征着这件物品的功能:写字台实际上是一个会让人产生并收集创意、思想和记忆的地方;也是能让学习或工作的人感到最为私密且个人的部分。

Peek-a-Book写字台的底座由鸡翅木色或摩卡色实心白蜡木制成,截面轮廓为三角形。抽屜前板由覆盖着Pelle Frau®

皮革包面的中密度纤维板制成,与异形桌面的覆面相搭配,异形桌面由杨木胶合板制成并带有中密度纤维板制成的底面。桌面、抽屜前板、側壁和后隔层小门的覆面均采用 Pelle Frau®ColorSphere®皮革。两个前抽屜后面设有专为电缆通道预留的隔层,可通过侧面触达。这款写字台提供与当前价目表上的版本相同的可选项。只有笔架提供专用于抽屜新宽度的不同尺寸: 大号笔架,覆盖Pelle Frau®ColorSphere®皮革包面。

BRERA 为了庆祝其诞生90周年,这款由Guglielmo Ulrich设计并由Poltrona Frau重色的历史悠久的长凳以一款特殊的彩色版本重新回归。

座椅的纹理仅由SC 66 India皮革制成的皮革色条带组成,条带沿着长凳的长边延伸,以免打破其轮廓并保持产品的形状整洁度,同时尊重Guglielmo Ulrich的作品中体现的典型的形状严谨与色彩折衷主义之间的平衡。而经线的特点则是冷暖色调的精致序列,始终取自Pelle Frau® ColorSphere®的宇宙: Darse-na、Bardiglio、Cocciopesto、Avorio和Garnet之间相互和谐对话,描绘出一幅具有高度当代感的几何与材料图案。其结构由两个锥形支撑件均采用鸡翅木饰面的实心白蜡木制成,也可根据要求提供摩卡色饰面。

Brera 90周年纪念版是一款特别版,可从米兰国际家具展之际开始订购,截止日期为2024年12月31日。其标志是一块放置在内部的金属牌。除了90周年纪念日版之外,同样以Pelle Frau® SC皮革制成的全新单色版本也首次亮相,它被添加至已存在于目录中的由Cuoio Saddle Extra皮革制成的版本中。

STOCK’N ROLL Sebastian Herkner Stock’n Roll 系列柜子由 Sebastian Herkner 设计,灵感来自珠宝盒,设计简洁,但细节精致、材质奢华。Stoc-k’n Roll 可以放在扶手椅旁,也可以用作床头柜。它呈圆柱形,饰面边缘略微凸出主体,形成一个把手,便于打开。实心白蜡木底座和支腿可采用天然饰面或鸡翅木色、摩卡色、原色或RAL漆面原色。

Peek-a-Book写字台的特点在于它那采用杨木胶合板制成的桌面,桌面带有中密度纤维板制成的底面。弯曲的前板由模压聚氨酯泡沫制成,向下折叠后形成写字台的底板并将抽屉和配件隔层隐藏在内部。其视觉效果就像一本用Pelle Frau®装订而成的珍贵书籍,象征着这件物品的功能:写字台实际上是一个会让人产生并收集创意、思想和记忆的地方;也是能让学习或工作的人感到最为私密且个人的部分。

Peek-a-Book写字台的底座由鸡翅木色或摩卡色实心白蜡木制成,截面轮廓为三角形。抽屜前板由覆盖着Pelle Frau®

TABLEWARE COLLECTION

Giobagnara x Poltrona Frau

与Giobagnara 联合出品的餐具系列配件,让您在摆放齐全的餐桌上用餐倍感愉悦,如圆形或矩形托盘、杯垫、盘垫、餐巾架、酒瓶冰桶、带支架的香槟篮和餐垫,即使在最宁静的晚餐中也能增添精致而珍贵的气息。饰面采用 India 色或 Quarzo Fumé 色的柔软 Pelle Frau® 真皮。

OFFICE COLLECTION

Giobagnara x Poltrona Frau

此外,与Giobagnara 还联合出品了办公系列——专为令办公室或工作地点更加舒适而设计的配件。笔筒或 A4 纸活页夹、鼠标垫、桌垫、废纸篓、信件架、笔记本电脑架等等,全部采用Pel-le Frau® 皮革装饰,颜色始终为 India 色或 Quarzo Fumé 色,精美加工无不体现在每一针缝线和最微小的细节上。

WATER ILLUSION Assia Karaguiozova

保加利亚设计师 Assia Karaguiozova 的花瓶系列 Water Illusion 新增了一款绿色调的新产品——Emerald Whi-spers。该作品由意大利玻璃大师采用烧注玻璃浆技术手工打造,在威尼斯琉璃厂完成,其不可复制的外形使每件作品都独一无二。其不规则的玻璃“瓣叶”呈流动状,是波浪的语言,材质厚度相当大。内侧的双重纹理在光线的照射下,仿佛水在桌面流动一般。四款雕塑般的作品(两个花瓶和两个碗,形态各异)展示了艺术与设计的融合之美。

PET COLLECTION

Poltrona Frau Style & Design Centre

设计的宠物系列也扩大了产品范围。可调节的宠物牵引绳由防撕加固编织带制成,具备 Pelle Frau® 皮革手柄,颜色有 Ume (搭配酒红色和黄色的带子)、Cypress (搭配绿色和驼色带子)和 India (搭配驼色和绿色带子)。装饰配件由镀锌黄铜制成,安全扣由抛光镍制成,带有徽标的金属牌由压铸Zama制成,抛光镍表面处理。提供有两个尺寸:小型和中型。项圈由提花织带制成,带有 Pelle Frau® 皮革环,颜色有 Ume、Cypress 和 India,与牵引绳的面料组合一致。项圈上有一个固定环和一个带扣的活动环,还有一个用于系扣牵引绳的 D 形环。提供有从小号到大号不等的四种尺码。背带也有四种尺码,可调节脖颈和胸口处的带长,采用与项圈和牵引绳相同的材料和表面处理。金属部件由抛光镍镀锌铜制成。碗是无铅奶油色釉面陶瓷材质,采用三烧技术制成。它可以与防滑垫搭配使用,垫子采用仿皮和聚酯纤维制成,上面印有装饰图案。软垫有中号、大号两个版本。该产品为米色: Beady面料 (67% 粘胶, 33% 棉)。软垫套面拆卸方便,既可与狗床一起使用,也可单独使用。

TABLEAU Simona Cremascoli 由 Simona Cremascoli 设计的新款装饰墙板 Tableau 采用了今年推出的 Pelle Frau® Nest 颜色。浓烈、明亮的色彩构成了一幅几何基本图形的画面,仿佛包豪斯的色彩练习。

Archibald — Bed

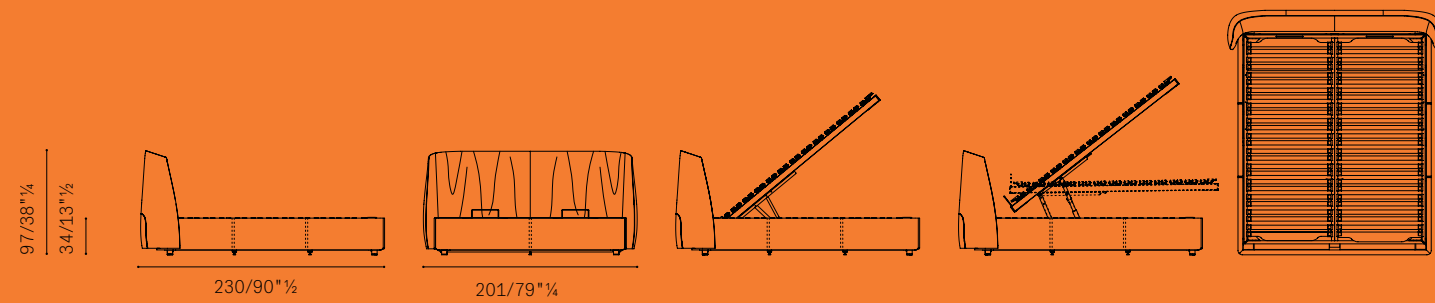

Archibald — Bed with storage unit

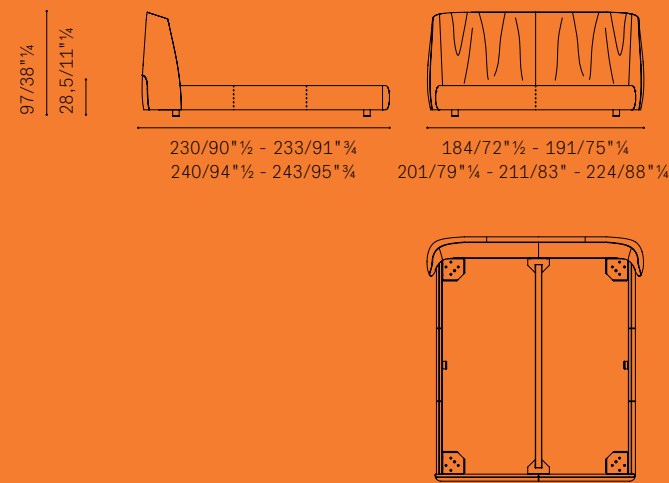

Archibald Bed - Finishes

BED

Feet. Cylindrical aluminum with a diameter of Ø60mm, available in two heights:

- h14 (standard)
- h17 (optional)

The feet come with floor protection caps made of plastic.

Feet finishes.

- Black painted
- Covered in leather (matching the bed covering).

Upholstery. Available in:

- Pelle Frau® ColorSphere® (SC) leather
- Pelle Frau® Nest leather

Aesthetic details. The Poltrona Frau logo is embossed in the center of the headboard's back.

Back of headboard. Available with covering in:

- Fabric (Poltrona Frau Jacquard fabric)
- Leather (matching the covering)

Mattress Length (except for "Queen-size" and "King-size" versions).

- 200 cm
- 210 cm

BED WITH STORAGE UNIT

Upholstery. Available in:

- Pelle Frau® ColorSphere® (SC) leather
- Pelle Frau® Nest leather

Back of headboard. Available with covering in:

- Fabric (Poltrona Frau Jacquard fabric)
- Leather (matching the covering)

Lifting mechanism. The access device to the storage compartment has two different types of opening mechanisms to choose from:

- With single movement: lifts the surface in an inclined position
- With double movement: lifts the surface in an inclined or horizontal position in one movement.



Please note:
this catalogue shows only some technical drawings, in order
to know all the availabilities please refer to the current price list.

Archibald Task Chair — Managerial chair

Pelle Frau® upholstery

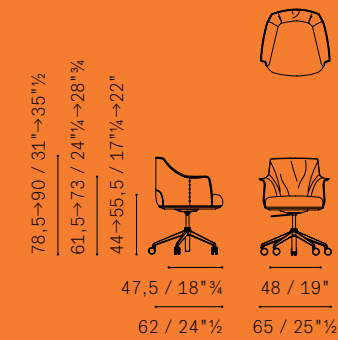

Archibald Task Chair — Managerial chair

Fabric upholstery

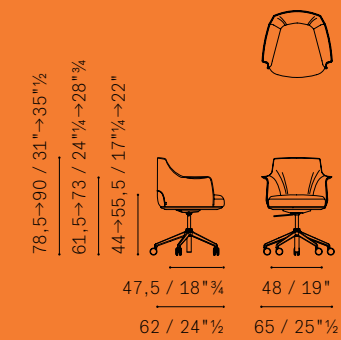

Archibald Task Chair — Executive Chair

Pelle Frau® upholstery



Archibald Task Chair — Executive Chair

Fabric upholstery

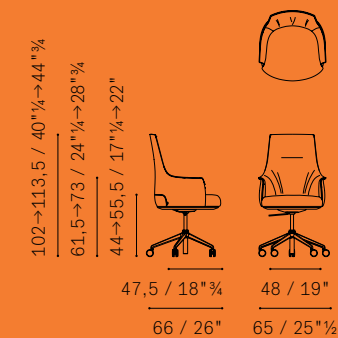

Archibald Task Chair - Finishes

Underseat protection casing. Made of thermoformed ABS and available finishes:

- embossed black
- upholstered in Pelle Frau® leather matching the shell

Base. Five-star base, made of die-cast aluminum, equipped with a mechanism allowing 360° rotation of the armchair and height adjustment.

Base finishes.

- Polished aluminum
- Black painted aluminum

Undershell cover. Made of heat-moulded ABS plastic with choice of upholstery solutions:

- leather matching the shell upholstery
- finely embossed ABS plastic

Supports.

- Soft self-braking swivel "W" wheels (recommended for floors such as granite, ceramic, marble, wood, and linoleum)
- Hard self-braking swivel "H" wheels (recommended for textile fiber surfaces)
- Swivel glides made of thermoplastic material with Teflon protection pads (suitable for all surfaces)

Wheel finishes.

- Chrome
- Black

Upholstery. Available in:

- Pelle Frau® ColorSphere® (SC)
- Pelle Frau® Nest
- Pelle Frau® Soul
- Fabric A
- Fabric B
- Fabric C
- C.O.M.

Functions.

- > 360° rotation
- > Seat height adjustment via gas spring
- > Adjustment of backrest and seat tilt and oscillation with the possibility of partialization and adjustment of oscillation force through an oscillating mechanism with lock. This mechanism allows the armchair to easily follow the body's movements.



Archibald — Dining Chair - Large Chair

Pelle Frau® upholstery
metal legs

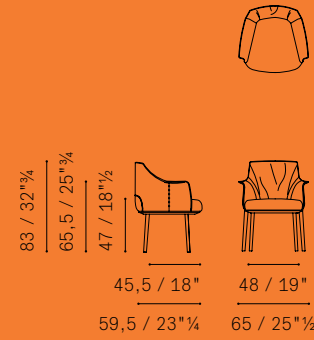

Archibald Large Dining Chair - Finishes

Base version. Fixed, in metal.

Metal base. The base under the seat is supported by 4 conical legs with an oval section, made of powder-coated steel and available in two finishes:
- burnished painted steel
- titanium painted steel

Upholstery.
- ColorSphere® (SC)
- Nest
- Soul
- Fabric A
- Fabric B
- Fabric C
- C.O.M.

Archibald — Dining Chair - Large Chair

Fabric upholstery
metal legs

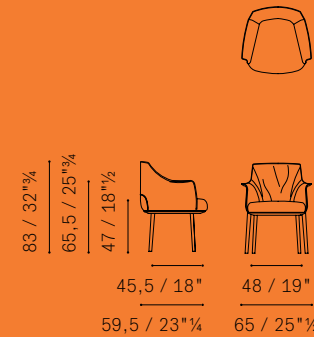

Brera 90th Anniversary Edition — 5-spokes swivel armchair with castors

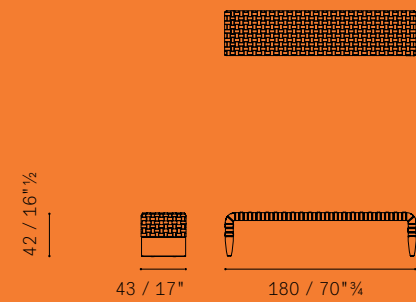

Brera 90th Anniversary Edition — Finishes

Structure and supports. Solid ash wood in two finishes:
- Ash in a moka stain (61)
- Ash in a wenge stain (32)

Upholstery. Achieved through the weaving of multicolored straps made of Pelle Frau® ColorSphere® (SC) leather, arranged according to a predefined chromatic sequence. On the weft (parallel to the long side of the bench), the straps are made in SC 66 India. In the warp, instead, the leather bands alternate in the following colors:
- SC 176 Darsena
- SC 233 Bardiglio
- SC 146 Coccio Pesto
- SC 01 Avorio
- SC 92 Garnet

Aesthetic details. The upholstery features tone-on-tone stitching and a clean-cut edge with matching color. The bench features a metal plaque in gunmetal finish, commemorating the 90th anniversary, positioned on the inner side of the leg



Please note:
this catalogue shows only some technical drawings, in order
to know all the availabilities please refer to the current price list.

Bretagne Gran Comfort — 2 Seater Sofa | Pelle Frau® structure

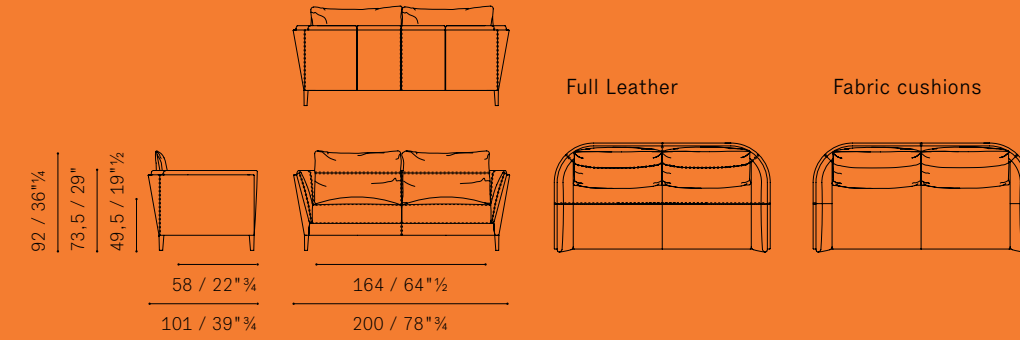

Bretagne Gran Comfort — Knits 2 Seater Sofa | Pelle Frau® Motif Knits structure

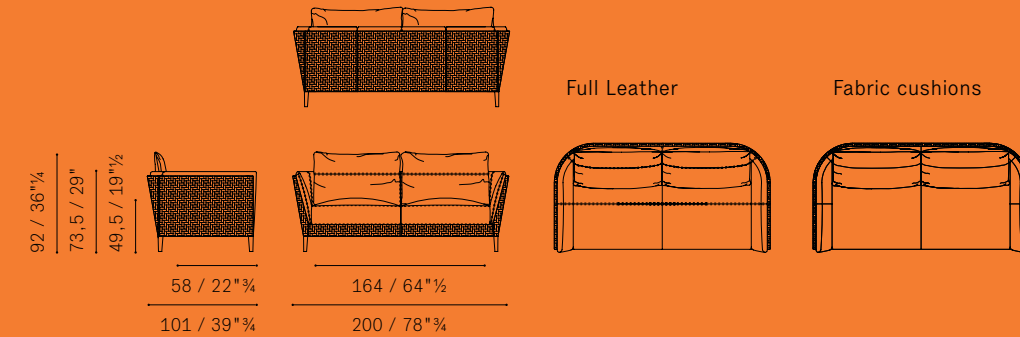

Bretagne Gran Comfort — 2 Seater Large Sofa | Pelle Frau® structure

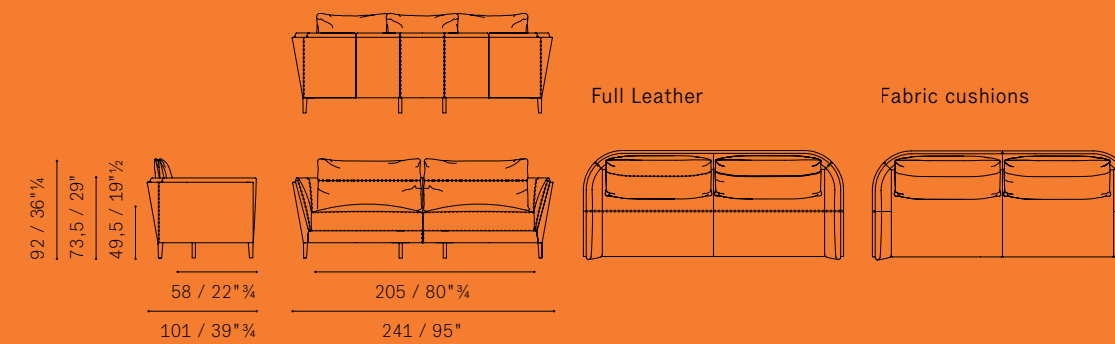

Bretagne Gran Comfort — Knits 2 Seater Large Sofa | Pelle Frau® Motif Knits structure

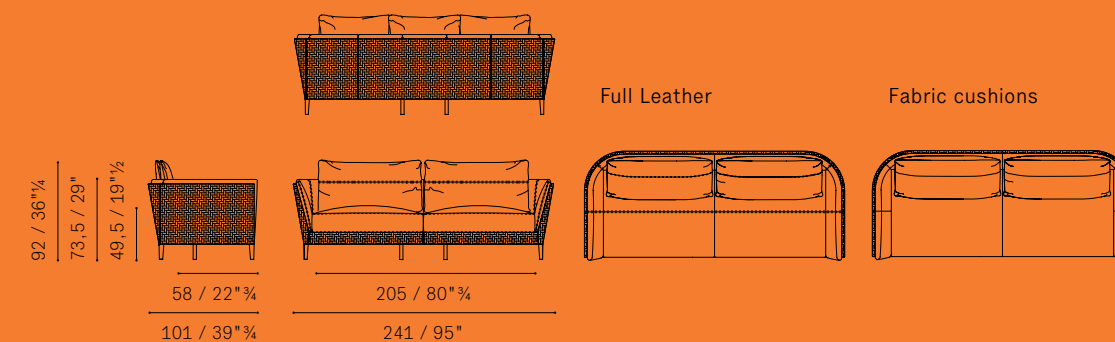

Bretagne Gran Comfort — 3 Seater Sofa | Pelle Frau® structure

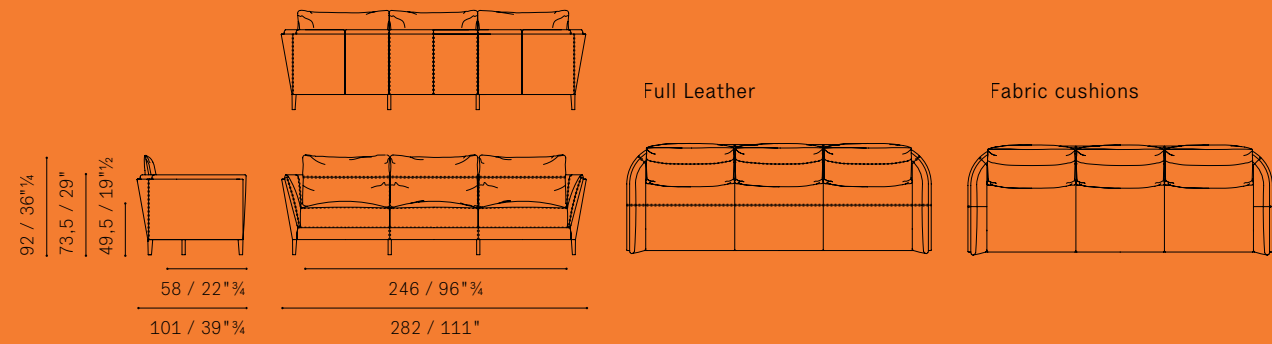

Bretagne Gran Comfort — Knits 3 Seater Sofa | Pelle Frau® Motif Knits structure

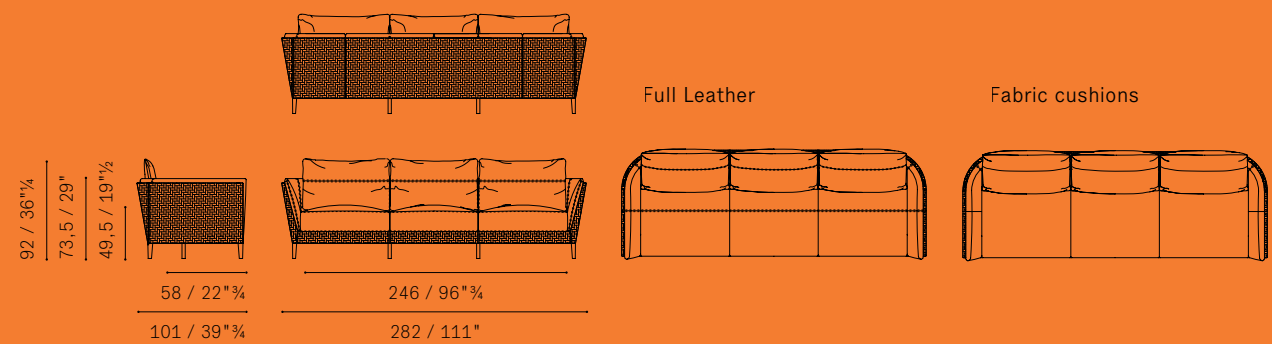

Bretagne Gran Comfort — Pouf | Pelle Frau® Motif Knits structure

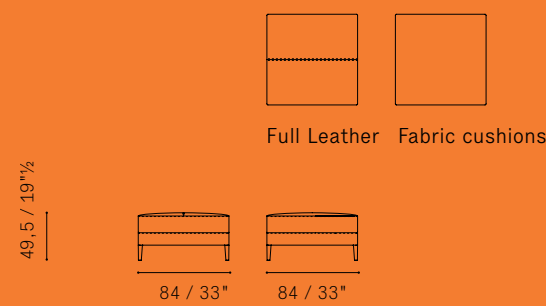

Bretagne Gran Comfort — Knits Pouf | Pelle Frau® Motif Knits structure

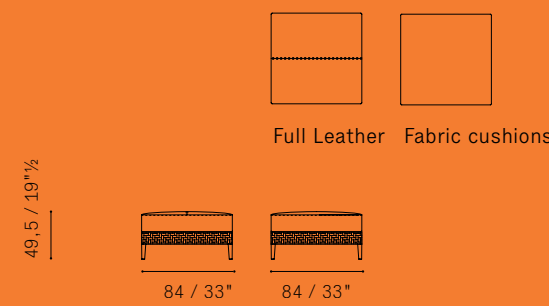

Please note:
this catalogue shows only some technical drawings, in order
to know all the availabilities please refer to the current price list.

Bretagne Gran Comfort — Finishes

Seat cushion.

- "Soft comfort" version, padded with feathers, polyester staple and a stabilising polyurethane foam insert.
- "Firm comfort" version, padded with polyurethane foam and polyester wadding.

Back cushions.

- 1 - The first, connected to the shell via a zipper, is padded with polyurethane foam and polyester wadding.
- 2 - The second consists of movable cushions resting on the backrest, padded with goose feathers.

Movable backrest cushions.

- "Soft comfort" version, padded with feathers, with a stabilising polyurethane foam insert on the lumbar zone.
- "Firm comfort" version, padded with polyester wadding and a polyurethane foam insert.

Feet.

Aluminum with gunmetal finish.

Upholstery. Entirely in Pelle Frau® (SC and Nest also available in two-tone**) or in options that combine multiple materials. The first upholstery is applied to the structure and base, while the second is applied to the backrest, armrests, and seat cushions.

- ColorSphere® (SC)
- ColorSphere® (SC) two-tone**
- Nest
- Nest two-tone**
- Soul
- Velvety
- ColorSphere® (SC) / Fabric A
- ColorSphere® (SC) / Fabric B
- ColorSphere® (SC) / Fabric C
- ColorSphere® (SC) / C.O.M.
- Nest / Fabric A
- Nest / Fabric B
- Nest / Fabric C
- Nest / C.O.M.
- Soul / Fabric A
- Soul / Fabric B
- Soul / Fabric C
- Soul / C.O.M.
- Motif Knits / ColorSphere® (SC)*
- Motif Knits / Nest*
- Motif Knits / Velvety*
- Motif Knits / Fabric A*
- Motif Knits / Fabric B*
- Motif Knits / Fabric C*
- Motif Knits / C.O.M.*

To check available fabrics, please refer to the dedicated "Combination models-fabrics pattern".

Please note. The Botè and Ziggy fabrics are not applicable.

*Attention. To avoid color transfers over time, it is recommended to pair Pelle Frau® Motif Knits with coverings in leather or fabric of the most similar color.

**N.B. The two-tone option includes a 5% surcharge compared to the price of the leather category.

N.B. The C.O.M. fabric must have a minimum height of 140 cm.

DUO — Chair

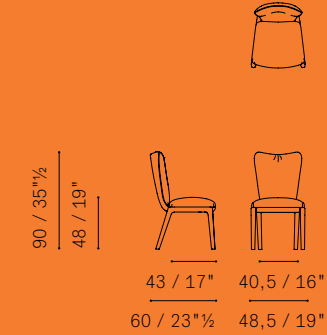

DUO — Small armchair

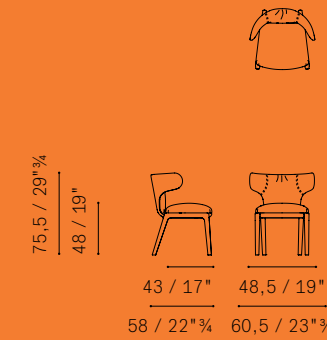

DUO — Finishes

Base. Consists of four legs made of solid ash wood with triangular section.

Leg finishes.

- Wengé stained ash (32)
- Mocha stained ash (61)

Additional special finishes with surcharge:

- Custom stained ash
- RAL lacquered ash to sample.

In these cases, a surcharge is applied with minimum delivery times of 60 days from the order and receipt of the sample.

NOTE: Special finishes stained to sample with light colors or with a "natural" effect may reveal the intrinsic variability of grain and tone of solid ash. The product may present slight differences in finish that should be considered normal and testify to the absolute authenticity of the wood and the uniqueness of the product.

Upholstery.

- ColorSphere® (SC)
- Nest
- Soul
- Fabric A
- Fabric B
- Fabric C
- C.O.M.

To check available fabrics, please refer to the dedicated "Combination models-fabrics pattern" table.

Removability. Not provided.



Ginger — Chair Saddle Extra external shell Fixed

5542101

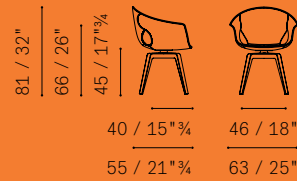
**Ginger** — Finishes

Edition. Ozwald Boateng x Poltrona Frau

Models

- fixed chair
- swivel chair

Base. Four solid ash wood legs with triangular profile available in the following finishes:

- Ash in a wenge stain (32)
- Ash in a moka stain (61)
- Natural Ash

Felt pads protect the floor.

Additional special finishes available for a surcharge:

- Ash stained according to sample
- Ash lacquered with RAL colours according to sample.

In these cases a surcharge is applied with minimum delivery times of 60 days from the order and receipt of the sample.

Upholstery. The shell is externally covered in Pelle Frau® Kenté and internally in Pelle Frau® ColorSphere® (SC).

The Pelle Frau® Kenté upholstery is available in the following colors:

- Red
- Purple
- Green
- Yellow
- Blue
- Black

Removability. Not possible.

**Ginger** — Chair Full upholstery shell Fixed

5542101

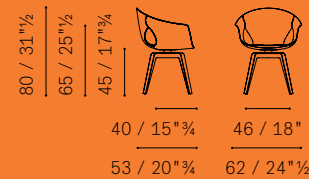
**Ginger** — Chair Saddle Extra external shell Swivel

5542101

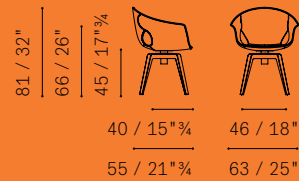
**Ginger** — Chair Full upholstery shell Swivel

5542101

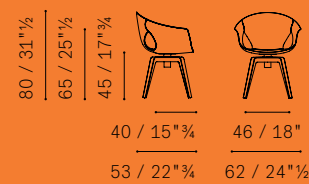

Please note:

this catalogue shows only some technical drawings, in order to know all the availabilities please refer to the current price list.

Ginger Ale — Armchair wood legs base / Totally upholstered shell fixed chair

5542017

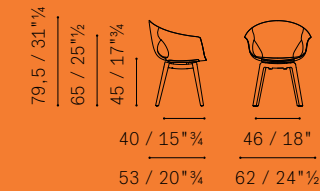
**Ginger Ale** — Armchair 4-legs base / Totally upholstered shell fixed chair

5542017

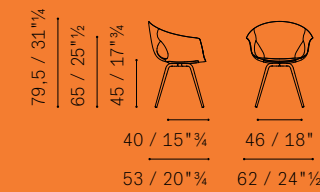
**Ginger Ale** — Full upholstery shell swivel chair

5542101

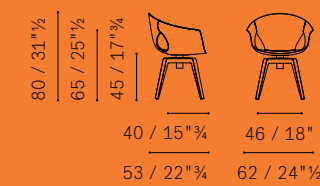
**Ginger Ale** — Armchair 4-spokes base / Totally upholstered shell

5542018

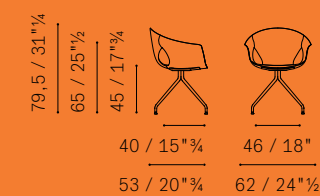
**Ginger Ale** — Armchair 4-legs base / External varnished shell fixed chair

5542017

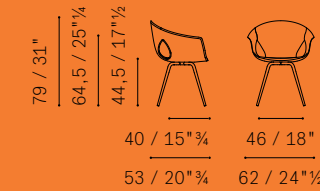
**Ginger Ale** — Full upholstery shell Fixed chair swivel chair

5542101

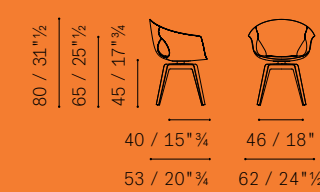
**Ginger Ale** — Armchair 4-spokes base / External varnished shell fixed chair

5542018

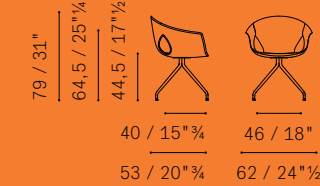
**Ginger Ale** — Armchair column base / External varnished shell

5542016

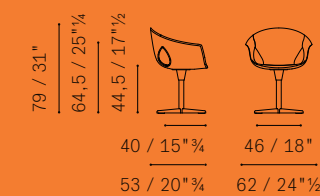

Ginger Ale — Armchair column base / Totally upholstered shell

5542016

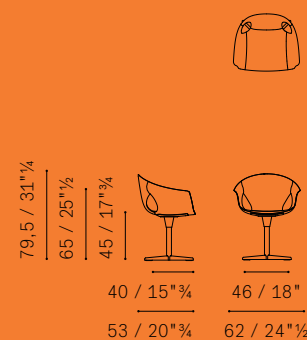
**Ginger Ale** — Armchair 5-spokes base with castors / External varnished shell

5542017

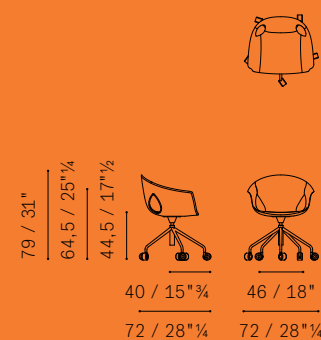
**Ginger Ale** — Armchair 5-spokes base with castors / Totally upholstered shell

5542017

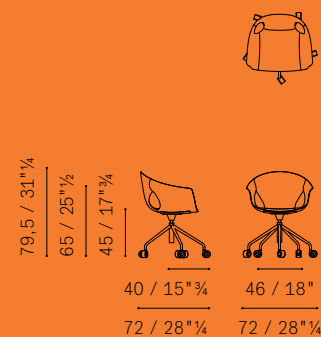
**Ginger Ale** — Armchair 5-spokes base with castors and adjustable height / External varnished shell

5542017

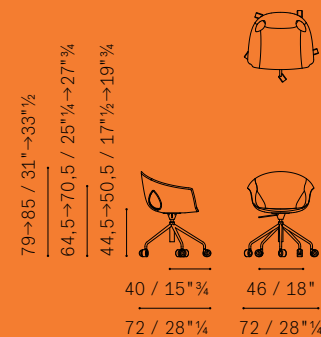
**Ginger Ale** — Armchair 5-spokes base with castors and adjustable height / Totally upholstered shell

5542017

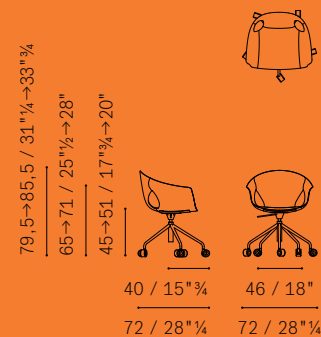

Please note:
this catalogue shows only some technical drawings, in order
to know all the availabilities please refer to the current price list.

Ginger Ale — Finishes**Edition. Oswald Boateng x Poltrona Frau**

Models. Ginger Ale can be configured to create numerous variants by combining one of the available bases with a painted shell or mixing a base with a shell upholstered entirely in leather or fabric.

Base.

In wood:

- 4-leg wooden base.

In painted steel:

- 4-leg base

- 4-spoke base

- Column base (fixed or swivel)

- 5-spoke base with castors (fixed or adjustable height).

Upholstery. The shell is externally covered in Pelle Frau® Kenté and internally in Pelle Frau® ColorSphere® (SC).

The Pelle Frau® Kenté upholstery is available in the following colors:

Red

Purple

Green

Yellow

Blue

Black

Removability. Not possible.

4-LEG WOODEN BASE

Made from triangular-section solid ash wood and available in the following finishes:

- Ash with a wenge stain (32)

- Ash with a moka stain (61)

- Natural Ash

Felt pads protect the floor.

Additional special finishes available for a surcharge:

- Ash stained according to sample

- Ash lacquered with RAL colours according to sample.

In these cases a surcharge is applied with minimum delivery times of 60 days from the order and receipt of the sample.

Please Note: the wooden base cannot be configured with the painted shell but only with the fully upholstered shell.

BASE IN PAINTED STEEL

Available in the following finishes:

- Cemento (44)

- Antracite (45)

Please note: when the chosen shell is painted, the base will be painted in the same finish.

4-leg base. Metal base with 4 conical legs fitted with:

- Plastic protective caps

- Adjustable black plastic caps with felt pads (in this case the height of the armchair rises by 1 cm)

4-spoke base. Steel base with adjustable black plastic caps with felt pads.

Column base. Steel base with black plastic caps, in two versions:

- Fixed

- Swivel version with shock-absorbing device and automatic return to starting position.

5-spoke 360° base. Steel swivel base available in two variants:

- Fixed-height version

- Adjustable-height version with gas spring system.

The painted versions are equipped with soft W type self-blocking swivel castors (suitable for all types of floor) with black plastic support.



Happy Jack — 2-Seater sofa

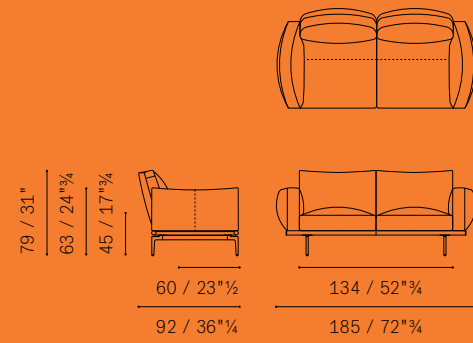

Happy Jack — Large 2-Seater Sofa

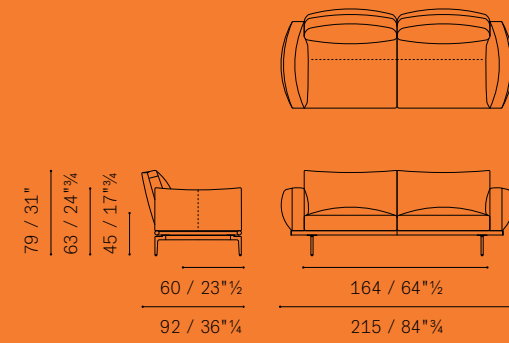

Happy Jack — Sectional 2-Seater Sofa

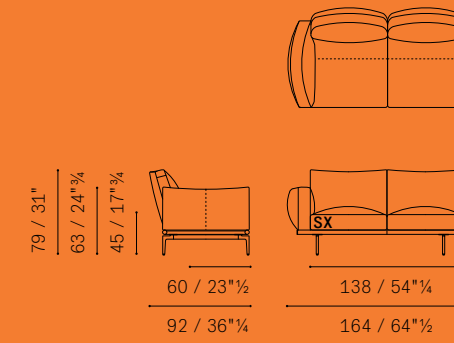

Happy Jack — Sectional Large 2-Seater Sofa

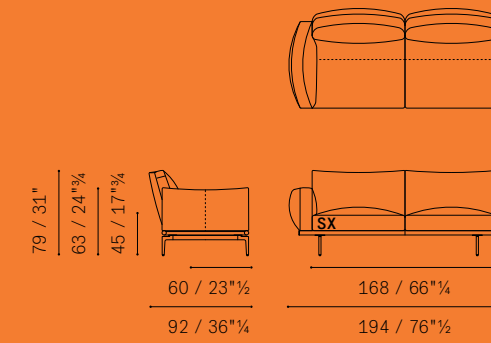

Happy Jack — 3-Seater Sofa

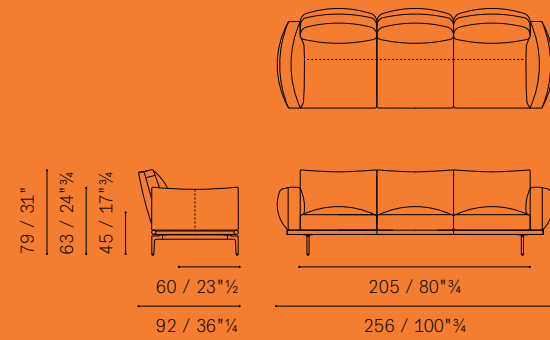

Happy Jack — Large 3 Seater Sofa

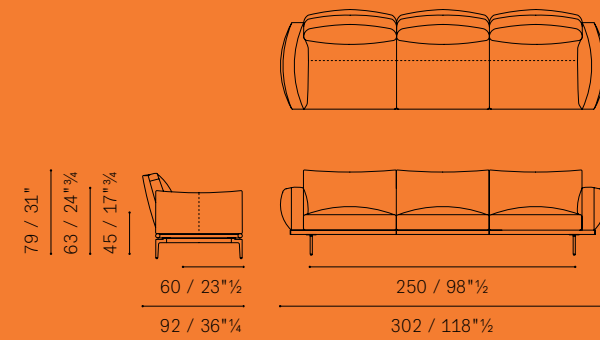

Happy Jack — Sectional 3 Seater Sofa

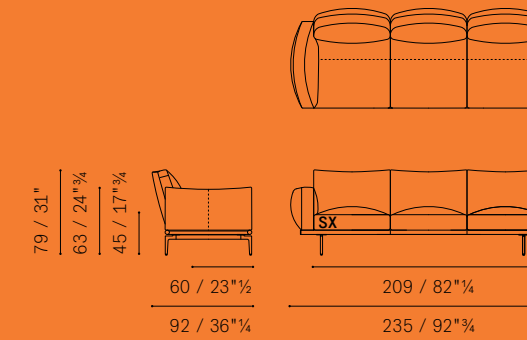

Happy Jack — Sectional Large 3 Seater Sofa

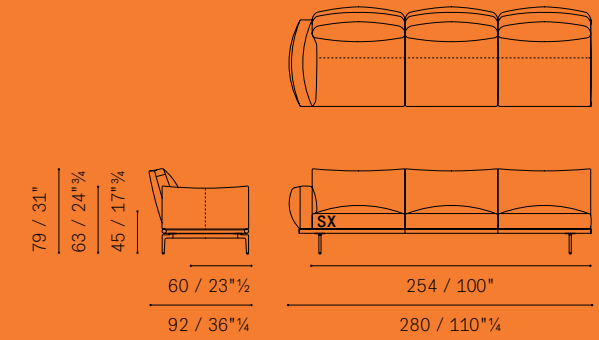

Happy Jack — Ottoman

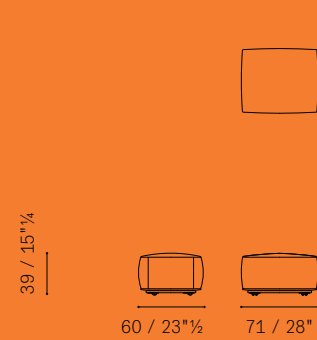

Happy Jack — Large Ottoman

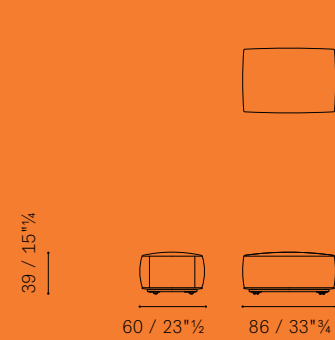

Happy Jack — Sectional Chaise Longue

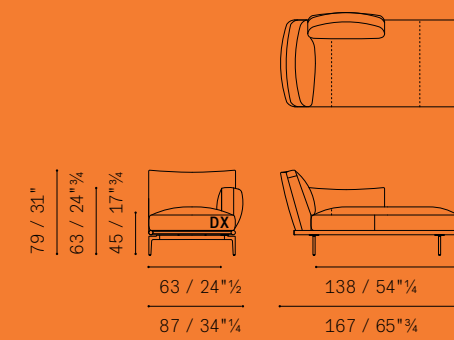

Happy Jack — Recliner Bench

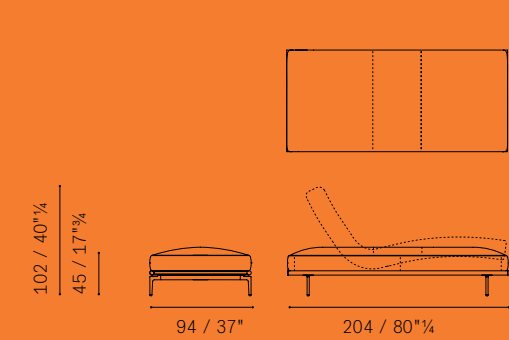

Happy Jack — Ottoman

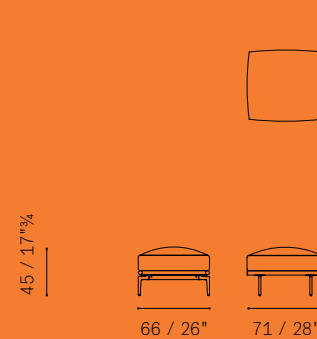

Happy Jack — Large Ottoman

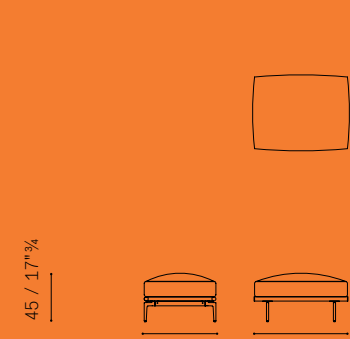

Happy Jack — Recliner Chaise Longue without armrest

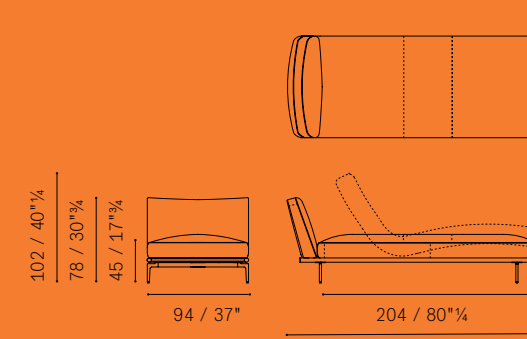

Happy Jack — Recliner Chaise Longue with armrest dx/sx

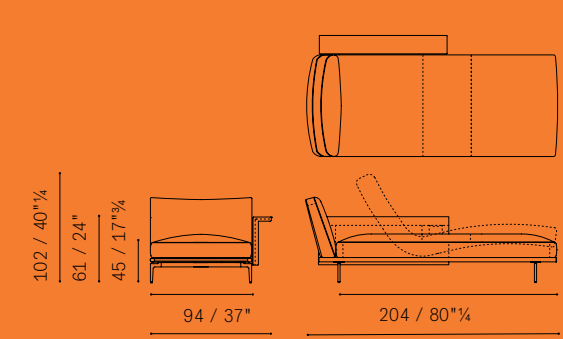

Please note:
this catalogue shows only some technical drawings, in order
to know all the availabilities please refer to the current price list.

Happy Jack — 45° Curved Sectional 2-Seater Sofa

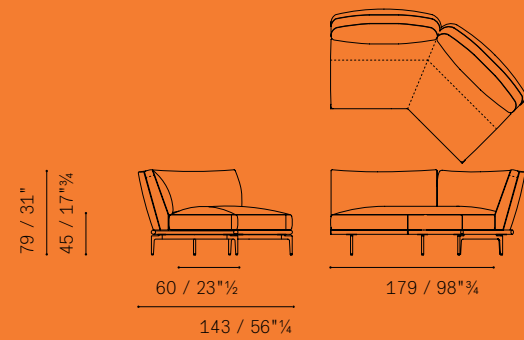

Happy Jack — 45° Curved 2-Seater Sofa 1 Left Arm

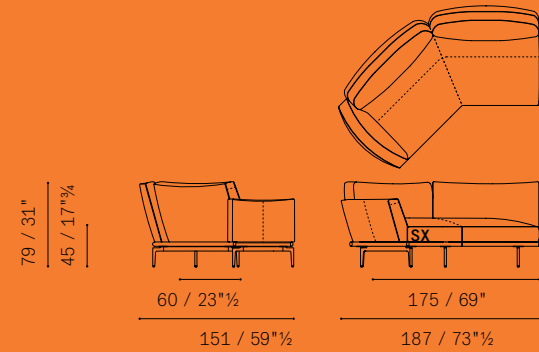

Happy Jack — Corner 2-Seater Sofa

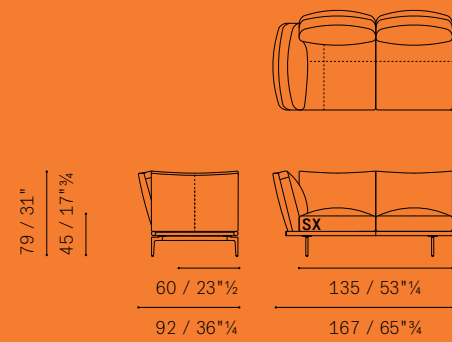

Happy Jack — Corner 2-Seater Sofa

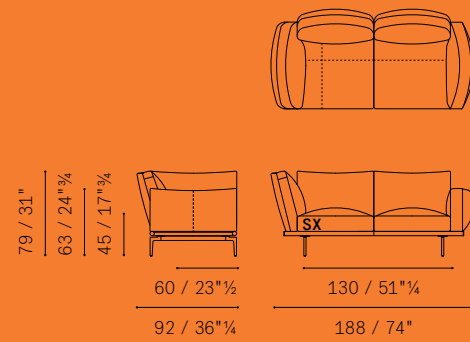

Happy Jack — Corner Large 2-Seater Sofa

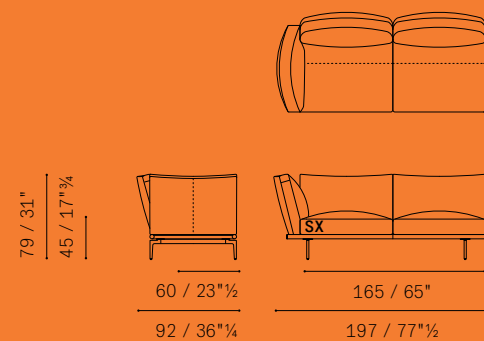

Happy Jack — Corner Large 2-Seater Sofa

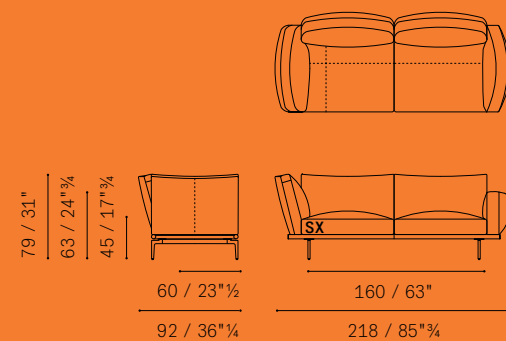

Happy Jack — Corner Large 3-Seater Sofa

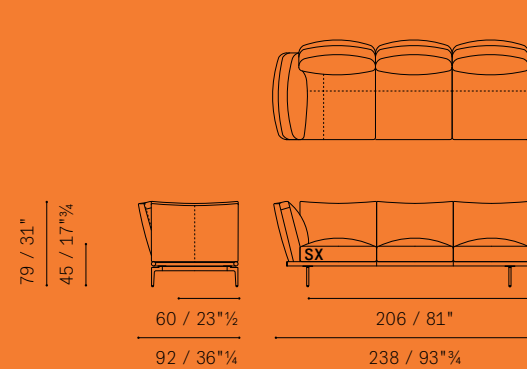

Happy Jack — Corner Large 3-Seater Sofa

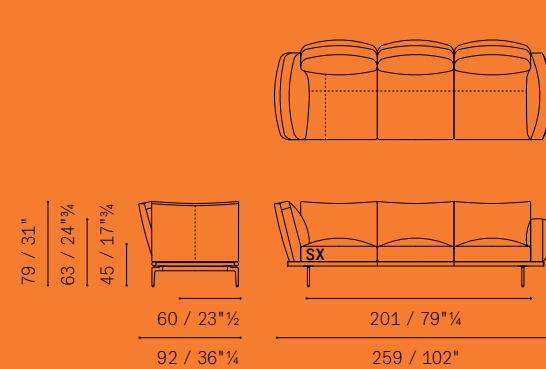

Please note:
this catalogue shows only some technical drawings, in order
to know all the availabilities please refer to the current price list.

Happy Jack — Corner Large 3-Seater Sofa

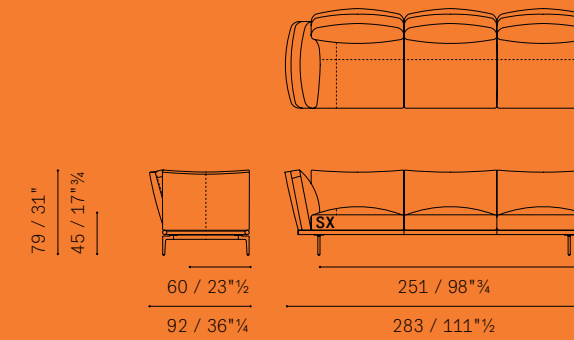

Happy Jack — Corner Large 3-Seater Sofa

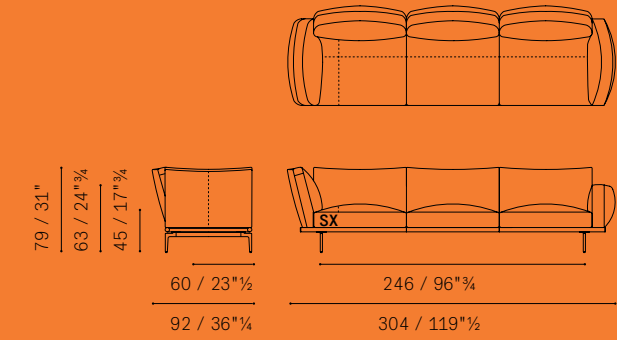

Happy Jack — Finishes

Base. Frame made of aluminium die. The end caps are made from zamak, with these finishes:

- ruthenium
- burnished

Upholstery. Fully upholstered in Pelle Frau® leather or in a combination of more materials. The former is applied to the base, while the latter is used for the seating, backrest and armrests.

- ColorSphere®
- ColorSphere® / Fabric A
- ColorSphere® / Fabric B
- ColorSphere® / Fabric C
- ColorSphere® / C.O.M.
- Nest
- Nest / Fabric A
- Nest / Fabric B
- Nest / Fabric C
- Nest / C.O.M.
- Soul
- Soul / Fabric A
- Soul / Fabric B
- Soul / Fabric C
- Soul / C.O.M.
- Velvety
- Saddle / ColorSphere®
- Saddle / Nest
- Saddle / Soul
- Saddle / Velvety
- Saddle / Fabric A
- Saddle / Fabric B
- Saddle / Fabric C
- Saddle / C.O.M
- Saddle Extra / ColorSphere®
- Saddle Extra / Nest
- Saddle Extra / Soul
- Saddle Extra / Velvety
- Saddle Extra / Fabric A
- Saddle Extra / Fabric B
- Saddle Extra / Fabric C
- Saddle Extra / C.O.M

Chaise Longue Recliner with armrest. In case an upholstery is chosen that combines the Saddle or Saddle Extra leather of the base with the fabric of the cushions, it is necessary to choose a color from the Pelle Frau® ColorSphere® range for the armrest upholstery. (Please see Upholstery application rules)

Removability. The fabric upholstery is removable for the seat cushions, backrests and armrests. The leather upholstery is removable only for the seat cushion.

Aesthetic details. The stitching is tone-on-tone for Pelle Frau® upholstery and in contrast for fabric upholstery.

Feet. In moulded aluminium available in two finishes to match the ends of the base:

- ruthenium
- burnished

Black nylon caps protect the floor. Central foot in black painted steel. For greater protection of delicate surfaces, the nylon tips can be replaced with felt pads or plastic tips.

Ottoman. Supports. Available in two versions:

- Four 360° swiveling wheels, concealed under the frame. They lower the pouf's height by 6 cm compared to the sofa seat height.
- Aluminium feet, in the same version and finishes as the sofa feet. They give the ottoman the same height as the sofa seating.



Martha/Ozwald Boateng x Poltrona Frau — Armchair

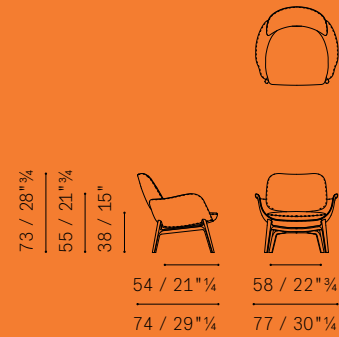

Martha/Ozwald Boateng x Poltrona Frau — Rocking armchair

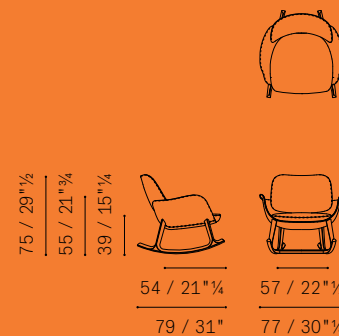

Martha — Finishes

Edition. Ozwald Boateng x Poltrona Frau

Base.

- formed by four legs
- rocking

Base finish.

- In solid wood:
- Ash in a wenge stain (32)
- Ash in a moka stain (61)
- Natural ash

Upholstery. The shell is externally upholstered in Saddle Extra leather and internally in Velvet Tribal fabric. The Velvet Tribal fabric is available in the following colors:

- Red
- Purple
- Green
- Yellow



Nice — Chair

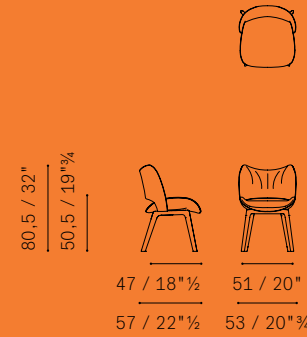

Nice — Finishes

Base. Comprising 4 single trestle legs, available in:

- Aluminum die-casting, with tips featuring interchangeable ends depending on the floor hardness
- Solid ash wood (Note: the wooden base reduces the seat height by 25mm).

Leg Finishes.

- Burnished painted aluminum
- Titanium painted aluminum
- Natural ash
- Wengé-stained ash (32)
- Mocha-stained ash (61)

Additional special finishes with surcharge:

- Custom-stained ash
- RAL lacquered ash.

Upholstery. Made entirely in Pelle Frau® leather or in Fabric, or in the options that combine several materials, leather or fabric for the inside of the seat (back and seat) and Saddle Extra saddle-leather for the external seat shell.

- ColorSphere® (SC) (also two-tone**)
- Nest (also two-tone**)
- Soul
- Fabric A
- Fabric B
- Fabric C
- C.O.M.
- Motif Weavers / ColorSphere® (SC)
- Saddle Extra / ColorSphere® (SC)
- Saddle Extra / Nest
- Saddle Extra / Soul
- Saddle Extra / Fabric A
- Saddle Extra / Fabric B
- Saddle Extra / Fabric C



Please note:

this catalogue shows only some technical drawings, in order to know all the availabilities please refer to the current price list.

Nymph — Small Table lamp

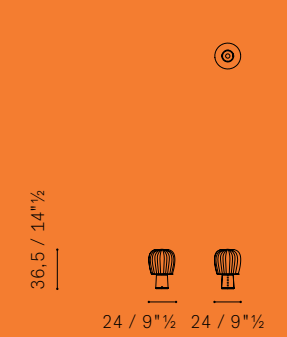

Nymph — Medium Table lamp



Nymph - Finishes

Certifications.

- CE
- Product compliant for sale in:
- Europe
- United Kingdom
- China
- USA
- Australia/New Zealand

Base. Shaped like a cone trunk, in natural brass finish and covered in leather.

Upholstery. Available in Pelle Frau® ColorSphere® leather in the following colors:

- SC 28 Seppia
- SC 34 Maggese
- SC 68 Sahara Marrone
- SC 136 Ginger Bread
- SC 274 Fresco Blue

Stitching. Contrast stitching.

Lampshade. Blown glass lampshade with ribbed processing, available in finishes:

- Satin Milk White
- Smoked

Lighting body. Consists of a cylindrical tube made of polymethyl methacrylate (PMMA), housing an LED module at the base. The surface texture of the cylinder provides a unique visual light effect.

LED Group Features.

- > LED Board 18W 3000K
- > Touch on/off switch
- > Dimmer functionality for light modulation up/down

Power Supply Group Features.

- > External transformer: 100-240V/out 24Vdc with interchangeable plugs (type A, C, G, and I)
- > Frequency 50-60 Hz
- > IP20 protection degree (dry location)
- > Power 25W
- > Electrical lighting appliance in class III

Electric cable. Length of 2.5 m, covered in black fabric, to be connected to an external transformer equipped with a plug.

Note. The light source can only be replaced by the manufacturer or its authorized service center.



Office Collection — Paper tray

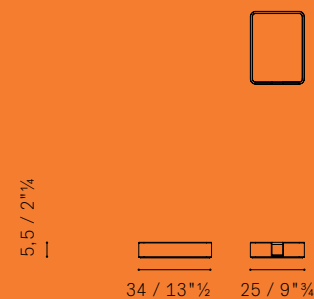

Office Collection — Desk blotter

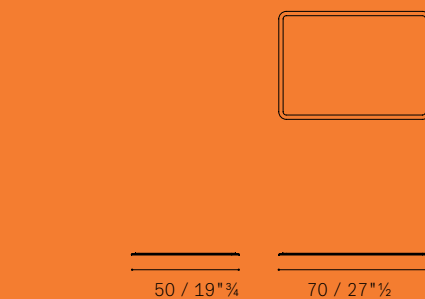

Office Collection — Envelope holder

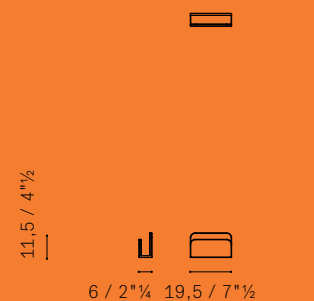

Office Collection — Pen holder

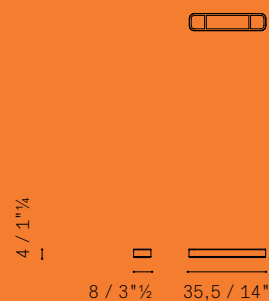

Office Collection — Laptop tray

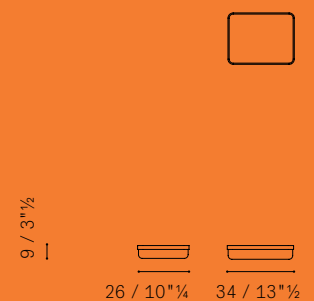

Office Collection — Mouse pad



Office Collection — Single wastepaper bin

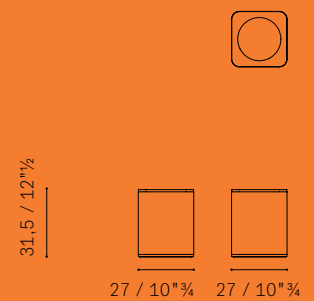

Office Collection — Single pen holder

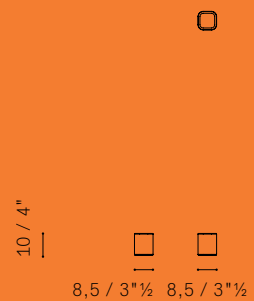

Please note:
this catalogue shows only some technical drawings, in order
to know all the availabilities please refer to the current price list.

Office Collection — Finishes

Rivestimento. In Pelle Frau® ColorSphere®, nelle varianti cromatiche:
- SC 31 Quarzo Fumé
- SC 66 India



Parka — Concave Armchair Without Armrests

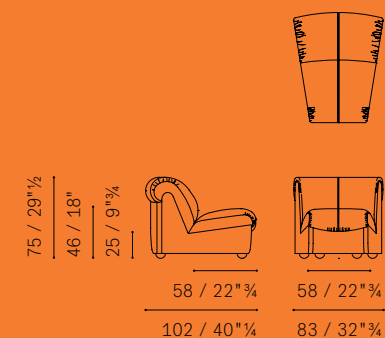

Parka — Concave Armchair With Armrest

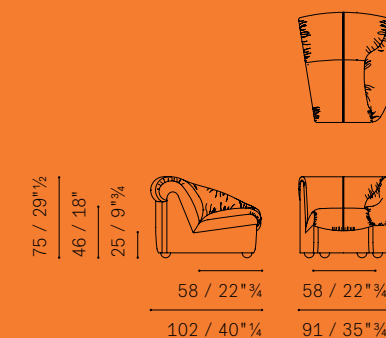

Parka — Convex Armchair With Maxi Armrest

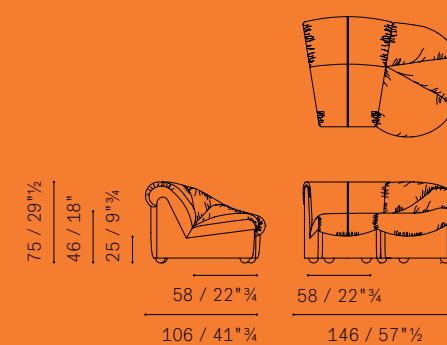

Parka — Convex Armchair Without Armrests

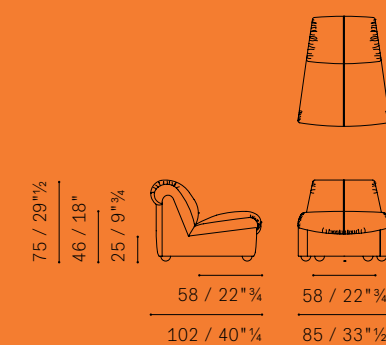

Parka — Convex Armchair With Armrest

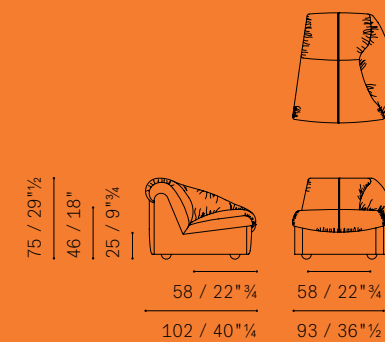

Parka — Concave Armchair With Maxi Armrest

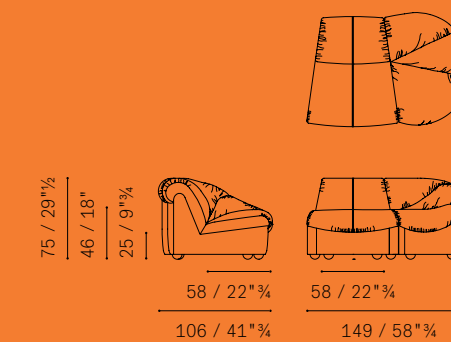

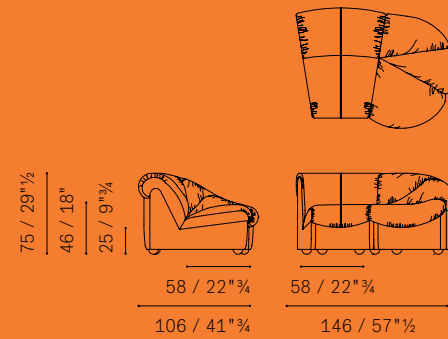
Parka — Concave Armchair With Maxi Armrest**Parka** — Finishes

Upholstery. Entirely in Pelle Frau® (also two-tone**) or in options that combine multiple materials. The first upholstery is applied to the base and structure, while the second is applied to the cushion block.

- ColorSphere® (SC)
- ColorSphere® (SC) two-tone**
- Nest
- Nest two-tone**
- Soul
- Velvety
- ColorSphere® (SC) / Fabric A
- ColorSphere® (SC) / Fabric B
- ColorSphere® (SC) / Fabric C
- ColorSphere® (SC) / C.O.M.
- Nest / Fabric A
- Nest / Fabric B
- Nest / Fabric C
- Nest / C.O.M.
- Soul / Fabric A
- Soul / Fabric B
- Soul / Fabric C
- Soul / C.O.M.

Removability. Not provided.

Stitching. Tone on tone.

Aesthetic details. The Poltrona Frau logo is hot-stamped on the back of the sofa's backrest.

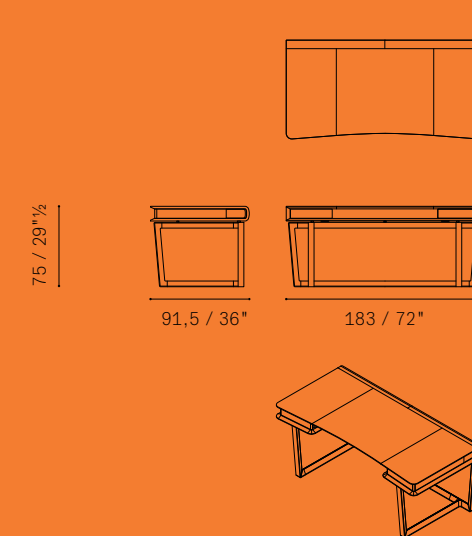
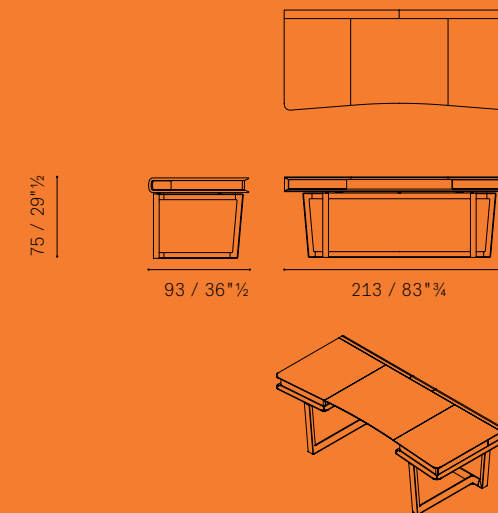

Please note:
this catalogue shows only some technical drawings, in order
to know all the availabilities please refer to the current price list.

Peek-a-book — Desk**Peek-a-book** — Desk Large**Peek-a-Book** - Finishes

Edition.

- Poltrona Frau
- Ozwald Boateng x Poltrona Frau

Finishes:

- ash in a wenge stain (32)
- ash in a moka stain (61)

Options.

- 1) cable raceway
- 2) wireless charging device*
- 3) pen holder tray for drawer
- 4) Arrangement of lateral compartment for housing electrical sockets
- 5) electrical socket

*Please note: Wireless charging device (2) is not available for the Ozwald Boateng x Poltrona Frau edition.

Pen holder tray (3). It is upholstered in Pelle Frau® ColorSphere® leather. It can be placed in the right or left drawer.

- for right drawer
- for left drawer

Arrangement for electrical socket accommodation (4).

- right compartment
- left compartment
- both

Electrical socket (5). Available only if you also choose the option of arrangement accommodation (4). Available types:

- Schuko
- UK
- FRANCE
- USB-A
- USB-C

POLTRONA FRAU EDITION

Upholstery. The top, front and sides of the drawers and doors for accessing the rear compartments are upholstered in Pelle Frau® ColorSphere®.

OZWALD BOATENG X POLTRONA FRAU EDITION

Upholstery. The top, front and sides of the drawers and doors for accessing the rear compartments are upholstered in Pelle Frau® Kenté. Available in the following colors:

- Red
- Purple
- Green
- Yellow
- Blue
- Black



Pet Collection — Pet bowl



Pet Collection — Leash Jacquard

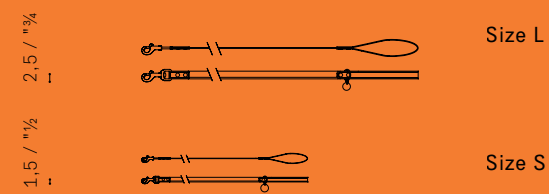

Pet Collection — Collar Jacquard

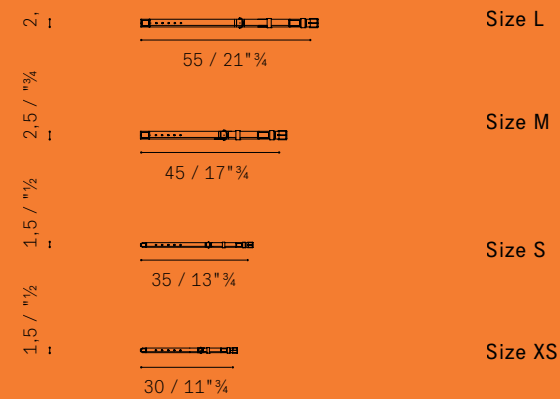

Pet Collection — Harness Jacquard



Pet Collection — Pet bowl pad

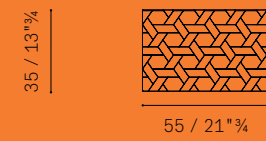

Pet Collection — Pet pillow

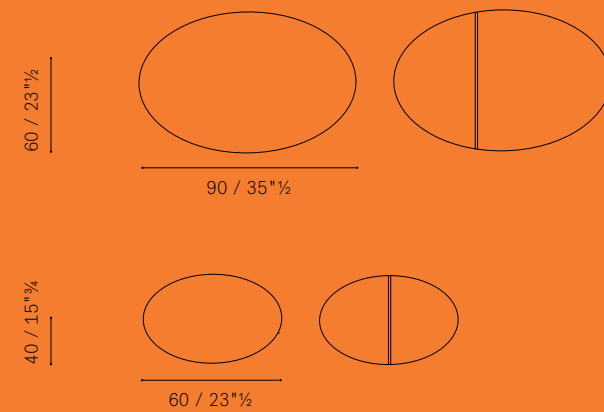

Pet Collection — Finishes

LEASH - COLLAR - HARNESS

Choose the size.

Versions.

- Burgundy: Pelle Frau® SC 256 Ume / burgundy and yellow ribbon
- Green: Pelle Frau® SC 209 Cypress / green and camel ribbon
- Camel: Pelle Frau® SC 66 India / camel and green ribbon

PET PILLOW

Sizes.

- Medium
- Large



Please note:
this catalogue shows only some technical drawings, in order
to know all the availabilities please refer to the current price list.

Pillow Cinema — Reclining Armchair

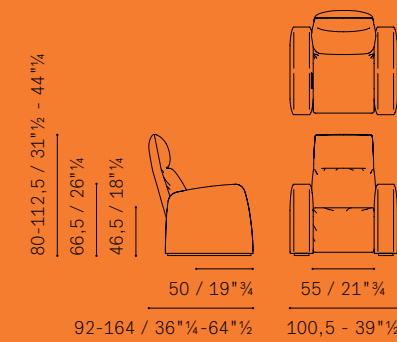

Pillow Cinema — Layout A | 2-Seater Layout

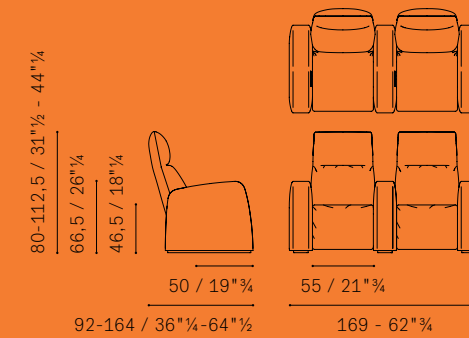

Pillow Cinema — Layout C | 3-Seater Layout

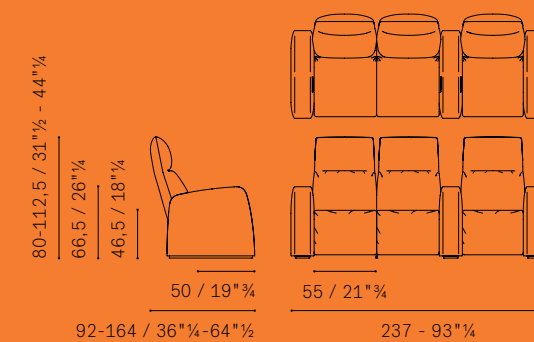

Pillow Cinema — Love Seat

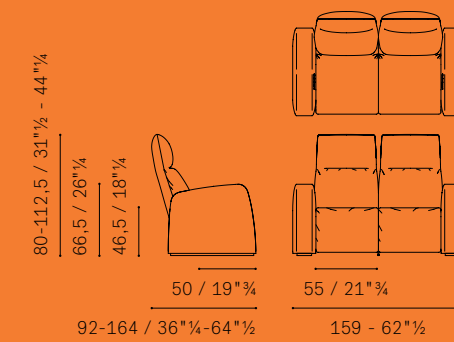

Pillow Cinema — Layout B | 3-Seater Layout

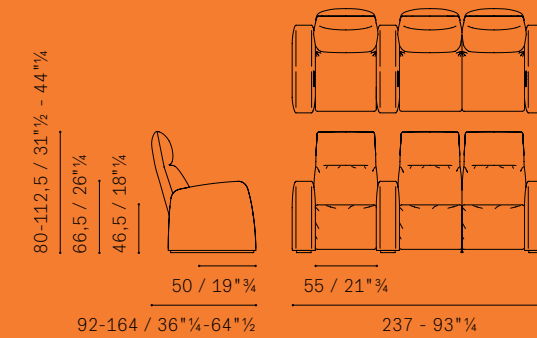

Pillow Cinema — Layout D | 3-Seater Layout

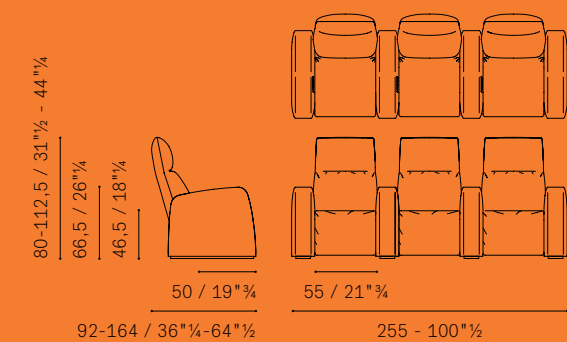

Pillow Cinema — Layout E | 4-Seater Layout

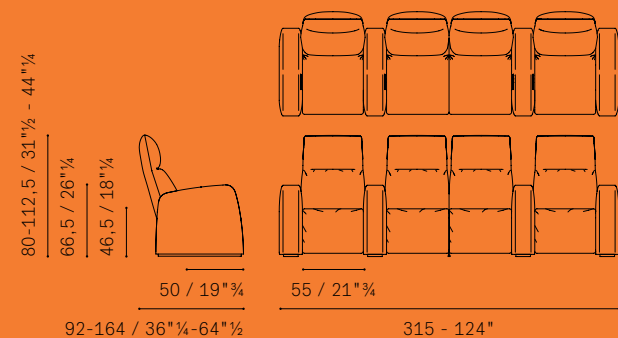

Pillow Cinema — Layout F | 4-Seater Layout

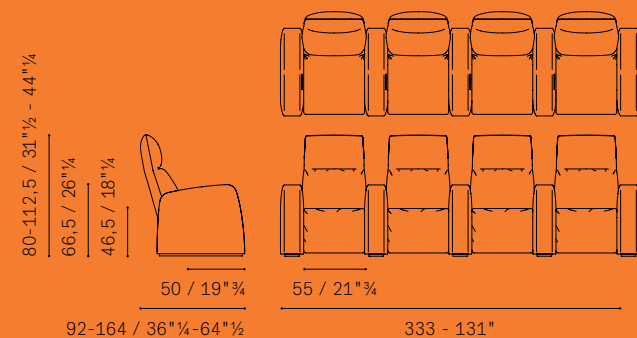

Pillow Cinema — Finishes

Versions.

- Reclining armchair with electric power grid
- Reclining armchair with rechargeable battery

Functions.

- > Adjustment of the headrest
- > Adjustment of the backrest
- > Adjustment of the footrest
- > Simultaneous adjustment of all elements to return to the starting position

Electric mechanism. The armchair is equipped with 3 motors that allow independent adjustment of the backrest, footrest, and headrest. The movement is controlled by a satin aluminum keypad, located on the inner side of the armchair.

Accessories.

- To be purchased according to the chosen version:
- Electric power supply
- Battery charger

Upholstery.

- In leather or fabric:
- Pelle Frau® ColorSphere® (SC)
- Pelle Frau® Nest
- Pelle Frau® Soul
- Pelle Frau® Velvety

Removability.

Not provided.

Aesthetic details.

Tone-on-tone stitching.

OPTIONAL

- 1) Beverage cooler/heater with wireless charging
- 2) Armrest lamp with USB-A charging station
- 3) Overarm table



Please note:
this catalogue shows only some technical drawings, in order to know all the availabilities please refer to the current price list.

Ren — Low Bookcase

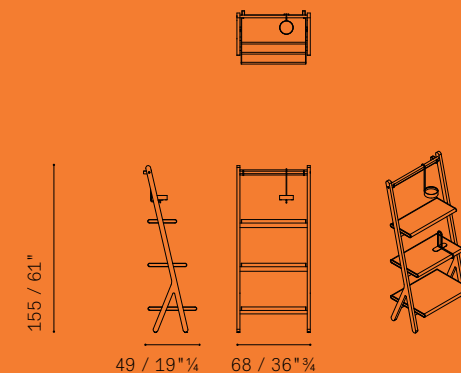

Ren — High Bookcase

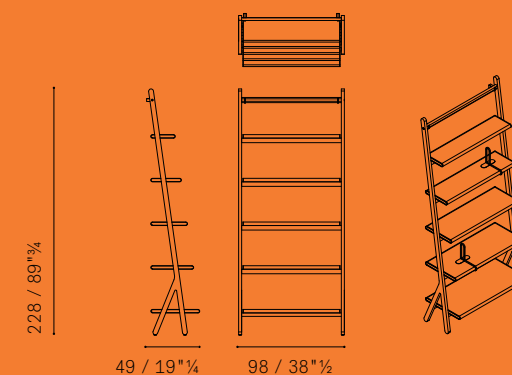

Ren — Freestanding Bookcase

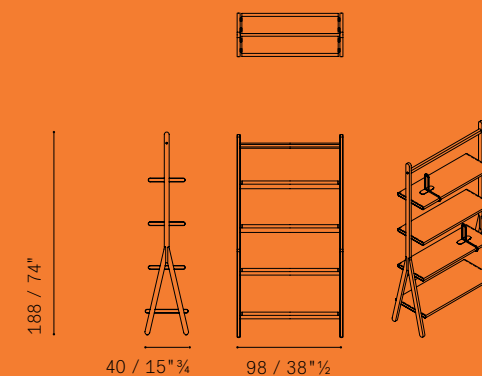

Ren Bookcase — Finishes

Edition. Oswald Boateng x Poltrona Frau

- Oswald Boateng x Poltrona Frau

Versions.

- self-supporting
- Freestanding Bookcase 98×188 cm
- for placement and anchoring to a wall
- High Bookcase 98×228 cm
- Low Bookcase 68×155 cm

Structure finish.

- Canaletto walnut
- Natural ash

Technical details. The Ren Low and High Bookcase Bookcases can only be used if fixed to a wall.

Shelves. Made of birch plywood and Canaletto walnut veneer.

Feet. Adjustable black plastic tips.

Key tray (only for the low bookcase). A circular shape, made of birch plywood in a Canaletto walnut veneer. It is fixed to the upper crosspiece with a brushed steel hook with brass paint.

Metal finishing details. Made of brass with a transparent matt surface treatment.

OPTIONAL ACCESSORIES: Bookends

Upholstery. In Pelle Frau® Kenté, available in the following colors:

- Red
- Purple
- Green
- Yellow
- Blue
- Black

Stitching. Tone-on-tone.



Squash — Armchair

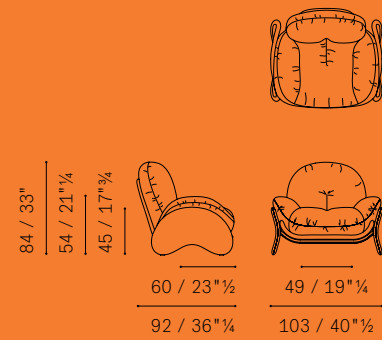

Squash — Coffee table

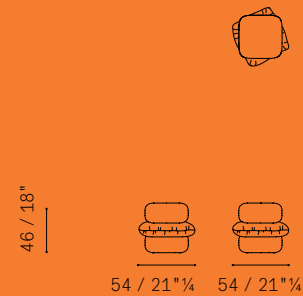

Squash — Pouf

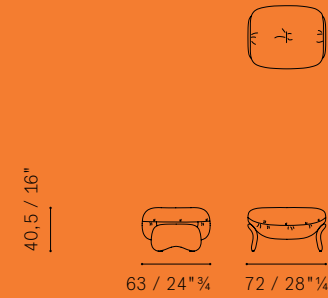

Squash Armchair, Pouf, Coffee table - Finishes

ARMCHAIR and POUF

Upholstery. Entirely in Pelle Frau® (also bicolored**) or in options that combine leather and fabric. The first upholstery is applied to the shell and sides, while the second is applied to the seat and backrest cushions.

- ColorSphere® (SC)
- ColorSphere® (SC) bicolored**
- Nest
- Nest bicolored**
- Soul
- Velvety
- ColorSphere® (SC) / Fabric A
- ColorSphere® (SC) / Fabric B
- ColorSphere® (SC) / Fabric C
- ColorSphere® (SC) / C.O.M.
- Nest / Fabric A
- Nest / Fabric B
- Nest / Fabric C
- Nest / C.O.M.
- Soul / Fabric A
- Soul / Fabric B
- Soul / Fabric C
- Soul / C.O.M.

Designer's tips. Faye Toogood recommends four Pelle Frau® ColorSphere® upholstery combinations:

- Cream: SC 51 Panna / SC 33 Travertino
- Sage: SC 176 Darsena / SC 173 Glauco
- Blue: SC 276 Mineral Blue / SC 254 Steel Blue
- Brown: SC 92 Garnet / SC 128 Carminio

COFFEE TABLE

Upholstery. The central cushion is upholstered in Pelle Frau® ColorSphere® (SC), color-coordinated with the lacquer finish of the blocks. Available combinations:

- Sage / SC 173 Glauco
- Blue / SC 254 Steel Blue
- Brown / SC 68 Sahara
- Cream / SC 33 Travertino

Optional: Leather mat



Please note:
this catalogue shows only some technical drawings, in order
to know all the availabilities please refer to the current price list.

Squash Mirror — Long Mirror



Squash Mirror — Wall Mirror

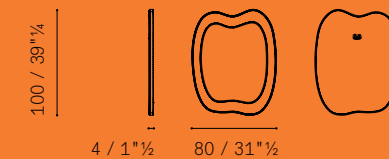

Squash Mirror — Pocket Mirror

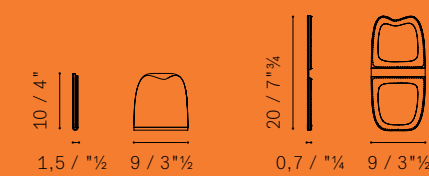

Squash Long Mirror & Wall Mirror - Finishes

Slightly padded with expanded polyurethane and fully covered in Pelle Frau® ColorSphere® (SC). Available in three colors:

- SC 254 Steel Blue
- SC 92 Garnet
- SC 67 Chiodi di Garofano

Stitching. Tone on tone

Positioning options. Long Mirror.

- Vertical wall mounting: The Mirror is equipped with a hook on the back for wall hanging

- Inclined floor positioning: It involves using a stand that makes the Mirror self-supporting (see "Optional")

Wall Mirror.

- Vertical wall mounting
- Horizontal wall mounting

OPTIONAL

Freestanding Stand (only for the "Long Mirror" model). Made of mediumdensity fiberboard and covered in Pelle Frau® SC, matching the frame.



Squash Pocket Mirror - Finishes

Colors. Three different color options are available:

- SC 68 Sahara
- SC 254 Steel Blue
- SC 127 Siam

Stitching. Tone-on-tone.

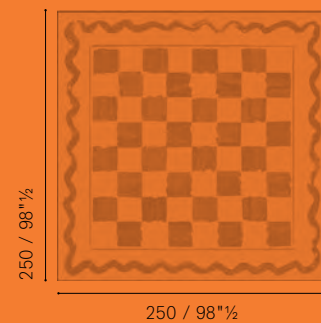
Squash Rug — 250×250 cm**Squash Rug** — Finishes

Dimensions.
- 250×340 cm
- 250×250 cm

Color combinations.
- Blue
Background: beige
Checkerboard: blue
Frame: brown
- Brown
Background: beige
Checkerboard: brown
Frame: red

Manufacturing technique. Hand-knotted Berber knot entirely by hand on wooden looms.

Quality. Approx. 27,900 knots/sqm.

Overall composition (structure and surface). 100% natural wool, carded and spun by hand. Thanks to the naturalness of the wool, the colors are absorbed unevenly, giving a particular intensity and three-dimensionality to the shades.

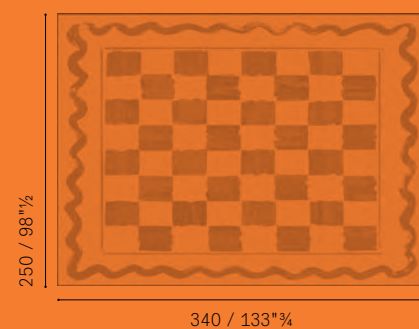
Squash Rug — 340×250 cm**Stock'n Roll** — Finishes

Storage compartment. Available with right-hand or left-hand opening. The opening direction is distinguished by the position of the hinges as seen from the front:

- Right-hand Opening (hinges on the right and handle on the left)
- Left-hand Opening (hinges on the left and handle on the right)

Internal equipment.
> Shelves
> Tray

Top. Available in the following versions:
- Covered in Pelle Frau® ColorSphere® (SC), to match the external or internal surface of the night table
- Semi-brilliant Calacatta Marble
- Semi-brilliant Arabescato Venato Marble
*N.B. The leather top is only available for the bedside table version covered in Pelle Frau® ColorSphere® (SC)

External and internal covering. In Pelle Frau®:
- ColorSphere® (SC)
- Nest
- Soul

Stitching. Tone on tone.

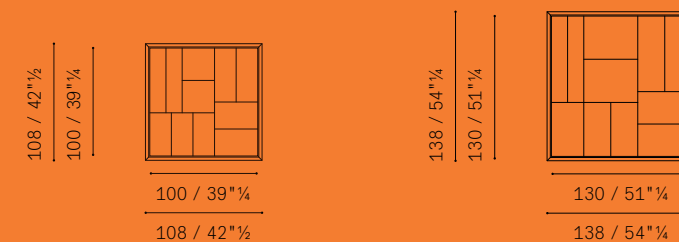

Please note:
this catalogue shows only some technical drawings, in order
to know all the availabilities please refer to the current price list.

Tableau — Tableau N'est Saison**Tableau** — Finishes

Size.
- 100×100 cm
- 130×130 cm

Combinaison de couleurs. Pelle Frau® Nest:
- Tableau N'est Saison, dans les couleurs Cinabro, Quarzo Rosa, Pietra di Sole, Giada Imperiale, Zircono, Adularia et Almandino.

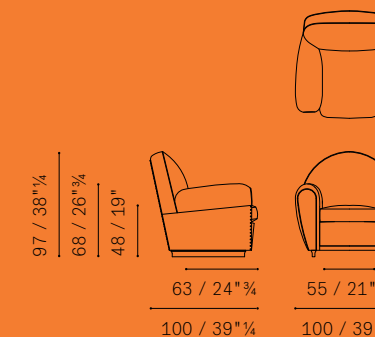
**Vanity Fair XC Imagine Edition** — Armchair**Vanity Fair XC Imagine Edition** — Finishes

Upholstery. Pelle Frau® leather. The white Pelle Frau® ColorSphere® Impact Less is decorated using a sophisticated method akin to silkscreen printing. Poltrona Frau employs digital printing that accentuates the intricate handdrawn motifs by Fornasetti, resulting in a slight and pleasant relief to the touch.

Removability. Not possible.

Aesthetic details. The external back and sides of the armchair are finished with a row of leather covered tacks.

Other details. Gunmetal grey plate.

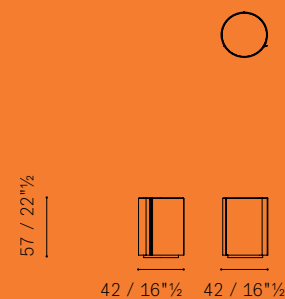
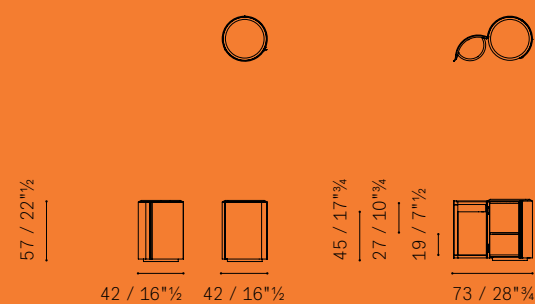
**Stock'n Roll** — Night table with leather top**Stock'n Roll** — Night table with marble top

Tableware — Bed Tray

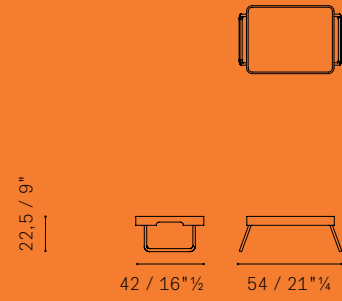

Tableware — Bottle Cooler

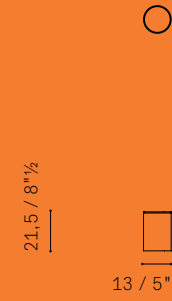

Tableware — Champagne Bucket

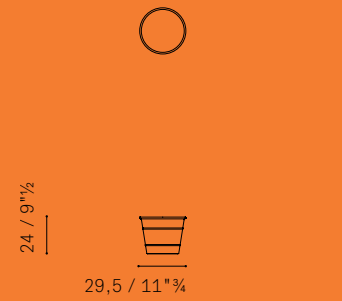

Tableware — Wallet Bucket

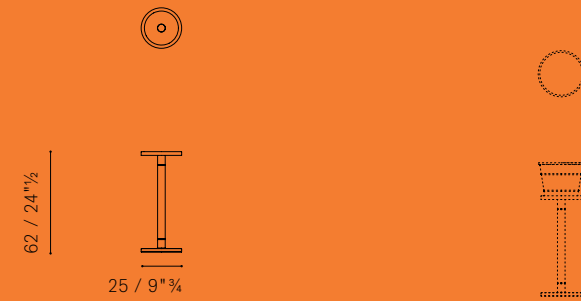

Tableware — Coaster Holder With 6 Coasters

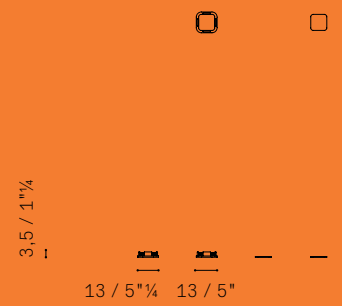

Tableware — Napkin Ring



Tableware — Placemat Holder With 6 Placemats

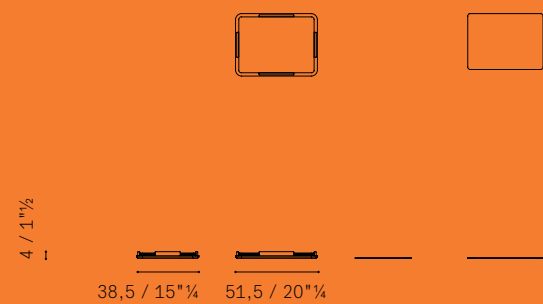

Tableware — Round Tray - Size L - M - S

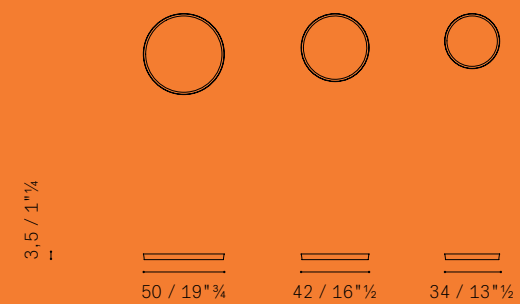

Please note:
this catalogue shows only some technical drawings, in order
to know all the availabilities please refer to the current price list.

Tableware — Rectangular Rounded Tray - M

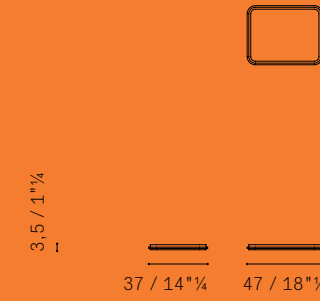

Tableware — Underplate

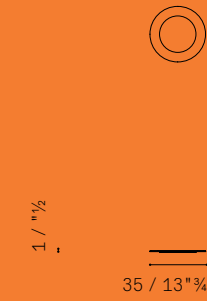

Tableware — Rectangular Rounded Tray - M / S

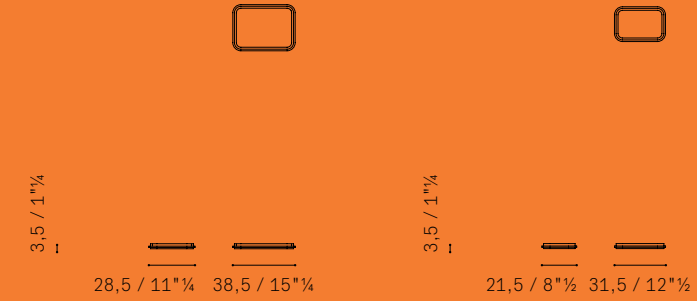

Tableware — Finishes

Upholstery. In Pelle Frau® ColorSphere®, nelle varianti cromatiche:
- SC 31 Quarzo Fumé
- SC 66 India



Water illusion — Small bowl

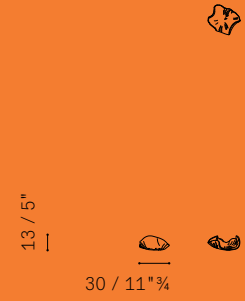

Water illusion — Large bowl

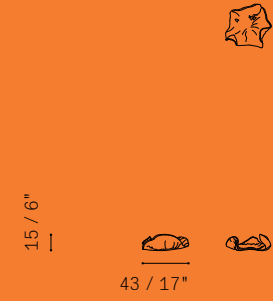

Water illusion — Small vase

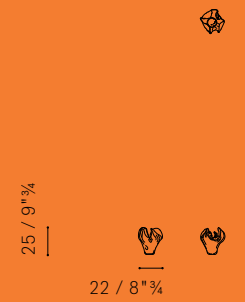

Water illusion — Large vase



Please note:
this catalogue shows only some technical drawings, in order
to know all the availabilities please refer to the current price list.



CONTACTS

Poltrona Frau S.p.A
a socio unico
Sede legale in Meda (MB)
Via Luigi Busnelli 1
20821 Italy

Sede operativa in Tolentino (MC)
Via Sandro Pertini 22
62029 Italy

Tel. +39 0733 909.1
Fax +39 0733 971600

www.poltronafrau.com

CREDITS

Project commissioned by the
Marketing & Communications
dept. of Poltrona Frau spa

Graphic design
studio FM milano

Lifestyle CGI Photography
Fuorifuoco Agency

Still-life Photography
Alessio D'Aniello

Post production/Color selection
Pan Group Milano

© POLTRONA FRAU 2024

Poltrona Frau reserves the right to modify the products and the components in this price list, without any prior notice.
Company with certified Quality Management System in accordance with ISO 9001, certified Environmental Management System in accordance with ISO 14001, certified Occupational Health and Safety Management System in accordance with BS OHSAS 18001, certified Chain of Custody System in accordance with Forest Stewardship Council® FSC-STD-40-004 (FSC-C153281).

Company subject to management and co-ordination of Haworth Italy Holding S.r.l.

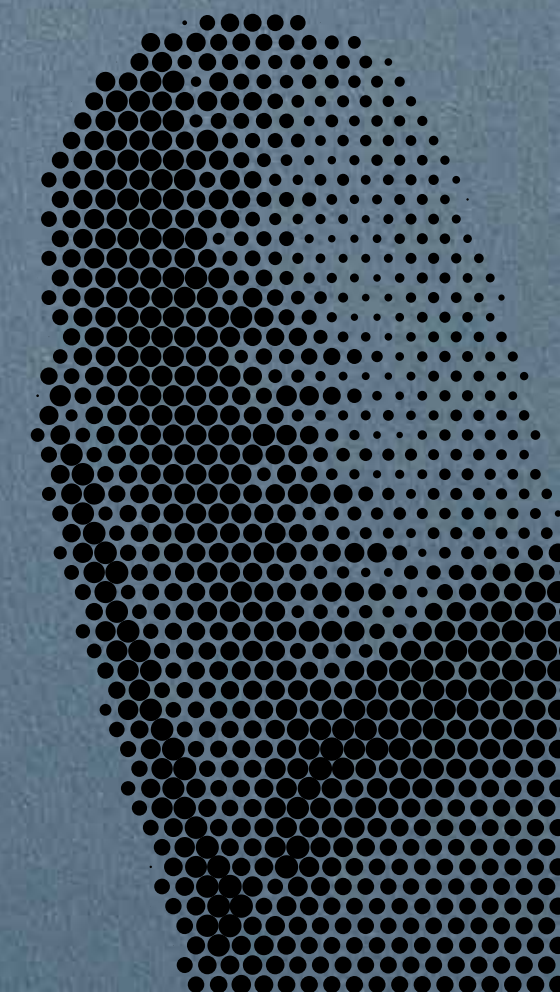

1012345-0000-04/24

