

True Over Time
Collection

2026









2026
True Over Time
Main Index

06	The 2026 True Over Time Collection		
78	Indoor Living	160	Work-Lab
	Sofas, Chairs and Stools		Lounge and Waiting spaces
78	Archibald Sofa System	160	Archibald Task President Chair
86	Blisscape Blisscape Deep		
96	Blisscape Low Table		
100	Archibald Slim Dining Chair	164	Beautilities
104	Archibald Stool Wood swivel version		Lamps
	Tables, Small Tables and Desks	164	Tullissè
108	Abigail	170	Gio Ponti Oro
112	Infinitamente 2.0	174	Moonbeam
118	Cuiré	180	Nymph Air
156	Stock'N Roll <i>Home-desk</i>		Tableware
	Bookcases, Living System and Storage Units	184	Chicware
122	Albero GFF100	188	Tableware collection
126	DomusCove		Accessories
132	Zabriskie	192	Traveller's Collection
	Poufs	200	Shiwa
138	Esedra	204	Office Collection
142	Kubaya	208	Lifestyle Collection
	Beds and Night Storage Units	213	Translations and Technical Drawings
146	LieLow		
152	LieLow Bedside table		
156	Stock'N Roll <i>Dressing Table</i>		
	Night System		
	DressCove*		

* DressCove novelties are showcased only in interior settings. Full details are available in the dedicated digital catalogue.

Indoor Living

Sofas, Chairs and Stools

-  **78** Archibald Sofa System
-  **86** Blisscape Blisscape Deep
-  **96** Blisscape Low Table
-  **100** Archibald Slim Dining Chair
-  **104** Archibald Stool Wood swivel version

Tables, Small Tables and Desks

-  **108** Abigail
-  **112** Infinitamente 2.0
-  **118** Cuiré
-  **156** Stock'N Roll Home-desk

Bookcases, Living System and Storage Units

-  **122** Albero GFF 100
-  **126** DomusCove
-  **132** Zabriskie

Poufs

-  **138** Esedra
-  **142** Kubaya

Beds and Night Storage Units

-  **146** LieLow
-  **152** LieLow Bedside table
-  **156** Stock'N Roll Dressing Table

Night System



DressCove*





Work-Lab

Lounge and Waiting spaces

-  **160** Archibald Task President Chair

Beautilities

Lamps

-  **164** Tullissè
-  **170** Gio Ponti Oro
-  **174** Moonbeam
-  **180** Nymph Air

Tableware

-  **184** Chicware
-  **188** Tableware Collection

Accessories

-  **192** Traveller's Collection
-  **200** Shiwa
-  **204** Office Collection
-  **208** Lifestyle Collection

* DressCove novelties are showcased only in interior settings. Full details are available in the dedicated digital catalogue.

True Over Time *Collection*

With its 2026 Collection, Poltrona Frau celebrates an idea of authentic design, capable of enduring over time while preserving its meaning.

True Over Time expresses furnishings conceived to last—not only through the quality of materials and craftsmanship, but through their ability to evolve alongside the lives of those who choose them.

A balance between artisanal tradition, innovation and responsibility, where durability becomes a form of truth: objects that transform, gain character and, over time, come to hold stories, gestures and memories.



↖ ↑ Archibald Sofa System, Pelle Frau® Nest Silice





↑ ↗ Archibald Sofa System, Pelle Frau® Nest Silice
Shiwa vase, grey color
Baldwin small table (by Ceccotti Collezioni)





↖ Archibald Sofa System, Haruka fabric in Whity color and Pelle Frau®
Nest Silice for the base
Shiwa vase, grey color
Baldwin small table (by Ceccotti Collezioni)



↑ ↗ Archibald Sofa System, Haruka fabric in Whity color and Pelle Frau®
Nest Silice for the base
Water Illusion large bowl, Emerald Whispers color
Baldwin small table (by Ceccotti Collezioni), Tortora coloured glass
top with ash in a wenge stain structure





↑ Archibald Sofa System, Haruka fabric in White color and Pelle Frau® Nest Silice for the base



↑ Archibald Sofa System, Haruka fabric in White color and Pelle Frau® Nest Silice for the base
Baldwin small table (by Ceccotti Collezioni), coloured glass top with ash in a wenge stain structure



↖ ↑ Moonbeam floor lamp, Pelle Frau® SC 04 Latte
↖ Shiwa vase, grey color
Baldwin small table (by Ceccotti Collezioni)







↖ ↑ Blisscape Deep sofa with deep end low table, Pelle Frau® SC 80 Bruno Havana leather structure with cushions in Zahara fabric, Silver Hemp color. The end low table is in Pelle Frau® SC 80 Bruno Havana leather
 Blisscape Low table 150x40, Pelle Frau® SC 80 Bruno Havana with Ombra di Caravaggio marble top
 Blisscape Low round table 100x100, Pelle Frau® SC 80 Bruno Havana with Ombra di Caravaggio marble top
 DomusCove living system – uprights and fronts of drawer chests and flap-door storage units in Pelle Frau® SC 66 India leather; Calacatta marble tops; bronzed glass shelves; Gold Walnut sides.



Blisscape Deep sofa with deep end low table, Pelle Frau® SC 80 Bruno Havana leather structure with cushions in Zahara fabric, Silver Hemp color. The end low table is in Pelle Frau® SC 80 Bruno Havana leather
 Blisscape Low table 150x40, Pelle Frau® SC 80 Bruno Havana with Ombra di Caravaggio marble top
 Blisscape Low round table 100x100, Pelle Frau® SC 80 Bruno Havana with Ombra di Caravaggio marble top
 Memoria rug, Ecrù color
 Dezza 24 armchairs, Pelle Frau® SC 59 Noce di Pecan with cushions in Cadence Canyon and black lacquered ash feet



↑ ↗ **Blisscape** Deep sofa with deep end low table, Pelle Frau® SC 80 Bruno Havana leather structure with cushions in Zahara fabric, Silver Hemp color. The end low table is in Pelle Frau® SC 80 Bruno Havana leather **DomusCove** living system -- uprights and fronts of drawer chests and flap-door storage units in Pelle Frau® SC 66 India leather; Calacatta marble tops; bronzed glass shelves; Gold Walnut sides.





↑ Moonbeam Large table lamp, Pelle Frau® SC 96 Mattone front disc
Kubaya pouf 86x86, Pelle Frau® Motif Knits Cinnamon



↑ DomusCove living system – uprights and fronts of drawer chests and flap-door storage units in Pelle Frau® SC 66 India leather; Calacatta marble tops; bronzed glass shelves; Gold Walnut sides
Dezza 24 armchairs, Pelle Frau® SC 59 Noce di Pecan with cushions in Cadence Canyon and black lacquered ash feet





↗ Blisscape Deep sofa, Pelle Frau® SC 67 Chiodi di Garofano structure with Pelle Frau® SC 177 Limo cushions
 Cuirè small table 85×85, Pelle Frau® SC 177 Limo with matched top
 Times Lounge armchair, Pelle Frau® SC 56 Siena with Moka ash structure
 Fidelio Small table, frassino Moka + SC 177 Limo
 Esedra Large, Pelle Frau® SC 177 Limo
 Esedra Medium with storage, Pelle Frau® SC 67 Chiodi di Garofano
 Esedra Small, Pelle Frau® SC 67 Chiodi di Garofano
 Dizzy rug, Sabbia color



- ↖ Blisscape Deep sofa, Pelle Frau® SC 67 Chiodi di Garofano structure with Pelle Frau® SC 177 Limo cushions
- Cuirè small table 85x85, Pelle Frau® SC 177 Limo with matched top
- Times Lounge armchair, Pelle Frau® SC 56 Siena with Moka ash structure
- Fidelio Small table, frassino Moka + SC 177 Limo
- Esedra Large, Pelle Frau® SC 177 Limo
- Esedra Medium with storage, Pelle Frau® SC 67 Chiodi di Garofano
- Esedra Small, Pelle Frau® SC 67 Chiodi di Garofano
- Dizzy rug, Sabbia color
- Gio Ponti Oro floor lamp





↑ Stock'N Roll Home-desk, Pelle Frau® SC 59 Noce di Pecan
 Nice chair, Pelle Frau® Soulful Diana with Aluminium base
 Nymph Air lamp, Fumè blown glass lampshade
 Albero GFF100 bookcase, American brown walnut structure with Santos Rosewood shelves
 ↖ Zabriskie Multimedia 234X53 cm, Pelle Frau® SC 177 Limo with Calacatta marble top
 Gio Ponti Oro floor lamp



↳ Abigail table 250×120, Calacatta marble top with Moka ash base
Archibald Slim dining chairs, Pelle Frau® SC 66 India with Moka ash legs
Nymph Air Medium lamps, Fumè blown glass lampshade
Chado rug, Rame color



↑ Zabriskie Low cabinet 284×53, Pelle Frau® SC 177 Limo with Calacatta marble top
Tullissè Medium Lamp, Pelle Frau® SC 278 Atlantic Blue and SC 233 Bardiglio





↑ ↗ Archibald Sofa System, Pelle Frau® SC 65 Vachette
Baldwin low table, Moka ash with Calacatta marble top (by Ceccotti Collezioni)
Archibald armchair, Pelle Frau® SC 254 Steel Blue
Gio Ponti Oro floor lamp
Calamandra rug, Champagne color



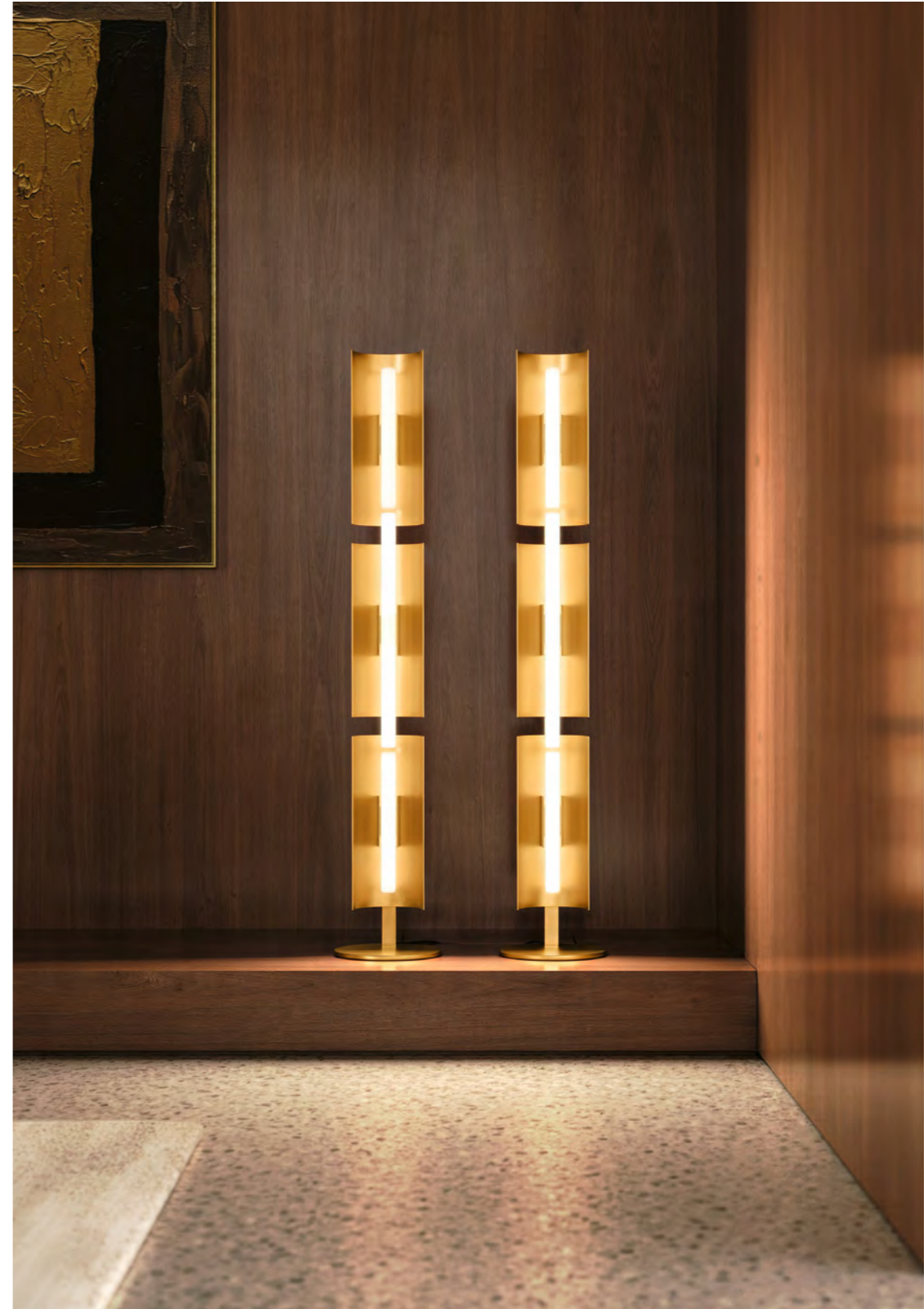

↖ ↑ Archibald Sofa System, Pelle Frau® SC 65 Vachette
Baldwin low table, Moka ash with Calacatta marble top (by Ceccotti Collezioni)
Archibald armchair, Pelle Frau® SC 254 Steel Blue
Gio Ponti Oro floor lamp
Calamandra rug, Champagne color



↗ Infinitamente 2.0, Calacatta marble with Pelle Frau® SC 187 Selva legs
 Lepli Chair, Pelle Frau® SC 46 Biscuit
 Zabriskie Low cabinet 234×53 cm with optional overhead shelves, Pelle
 Frau® SC 128 Carminio with trays in Pelle Frau® SC 56 Siena
 XI Linear suspension composition on bar, Emerald glass
 Memoria rug, Ecrù color



↖ **Infinitamente 2.0**, Calacatta marble with Pelle Frau® SC 187 Selva legs
 Lepli Chair, Pelle Frau® SC 46 Biscuit
 Zabriskie Low cabinet 234×53 cm with optional overhead shelves, Pelle
 Frau® SC 128 Carminio with trays in Pelle Frau® SC 56 Siena
 XI Linear suspension composition on bar, Emerald glass
 Memoria rug, Ecrù color



↖ ↑ Zabriskie Low cabinet 234x53 cm with optional overhead shelves,
Pelle Frau® SC 128 Carminio with trays in Pelle Frau® SC 56 Siena



Archibald Task President, Pelle Frau® SC 66 India
 Trust Desk, Pelle Frau® SC 59 Noce di Pecan/ SC 33 Travertino
 Archibald armchair, Pelle Frau® SC 69 Iroko
 Archibald sofa, Pelle Frau® SC 69 Iroko
 Ilary small table, Moka ash with Arabescato marble top
 DomusCove living system – uprights and fronts of drawer chests and flap-door storage units in Pelle Frau® SC 59 Noce di Pecan leather; bronzed glass shelves; Gold Walnut sides and tops



↖ ↑ Archibald Task President, Pelle Frau® SC 66 India
DomusCove living system – uprights and fronts of drawer chests
and flap-door storage units in Pelle Frau® SC 59 Noce di Pecan
leather; bronzed glass shelves; Gold Walnut sides and tops





↖ ↑ LieLow Bed, Pelle Frau® SC 66 India
LieLow Bedside tables, Pelle Frau® SC 66 India
Nymph Air lamp, Satin milk white blown glass lampshade
Chado rug, Earl Grey color
Tullissè Small table lamp, Pelle Frau® SC 148 Lacca and SC 31 Quarzo Fumè



↖ LieLow Bed, Pelle Frau® SC 66 India
LieLow Bedside tables, Pelle Frau® SC 66 India
Nymph Air lamp, Satin milk white blown glass lampshade
Chado rug, Earl Grey color



↖ ↑ Moonbeam floor lamp, galvanized brass aluminum front disc
Chado rug, Grigio Perla color
Stock'N Roll Dressing table, Pelle Frau® SC 66 India
Esedra Small, Pelle Frau® SC 176 Darsena
Memoria rug, Ecrù color





↑ DressCove Beauty, Pelle Frau® SC 51 Panna leather
Gaze Close Mirror, Pelle Frau® SC 66 India
Lepli Chair, Pelle Frau® SC 66 India



↑ Gaze Full mirror, Pelle Frau® SC 66 India
Esedra Small pouf, Pelle Frau® SC 93 Brossura
Esedra Medium pouf, Pelle Frau® SC 66 India



↗ DressCove Night System – uprights and fronts of drawer chests
 in Pelle Frau® SC 31 Quarzo Fumè leather; bronzed glass hinged doors;
 DressCove Beauty in Pelle Frau® SC 51 Panna leather
 Gaze Close mirror, Pelle Frau® SC 66 India
 Lepli Chair, Pelle Frau® SC 66 India
 Dizzy rug, Deep Red color
 Kubaya pouf 86x61, Pelle Frau® Motif Knits Smoked Tea
 Kubaya pouf 86x86, Pelle Frau® Motif Knits Cinnamon Root
 Bob small table, Pelle Frau® SC 93 Brossura

An evolution of the iconic Archibald armchair, Archibald Sofa System translates its original language into a modular system with more generous, welcoming proportions.

Poltroona Frau



Soft, enveloping forms, with clean-lined backrests free of additional cushions, are defined by the signature rippling details and refined, leather-inspired stitching.

The seating elements are designed as independent modules, allowing for flexible linear or corner configurations that adapt effortlessly to contemporary living spaces. The volumes, visually lightened by hidden feet, create a sense of suspension and elegance.



↖ ↑ Archibald Sofa System, Haruka fabric in Whity color and Pelle Frau® Nest Silice for the base
Baldwin small table (by Ceccotti Collezioni)

Jean-Marie Massaud Archibald Sofa System

True Over Time Collection

Archibald Sofa System



↖ ↑ Archibald Sofa System, Haruka fabric in Whity color and Pelle Frau®
Nest Silice for the base
Baldwin small table (by Ceccotti Collezioni)

The system is complemented by the Baldwin coffee tables by Ceccotti Collezioni, featuring sculptural forms, marble tops and solid wood structures that harmonize with the soft curves of the sofas, enriching compositions with functional and refined surfaces.

Upholstery is available in Pelle Frau® or removable fabric, always paired with a base fully upholstered in Pelle Frau®, emphasizing material continuity and attention to detail.



↖ ↑ Archibald Sofa System, Haruka fabric in Whity color and Pelle Frau®
Nest Silice for the base
Baldwin small table (by Ceccotti Collezioni)



↖ ↑ Archibald Sofa System, Haruka fabric in Whity color and Pelle Frau® Nest Silice for the base

The Blisscape sofa evolves into an even more complete and comfortable version, introducing a deeper seat, higher and adjustable armrests, and a further expanded modular system.



Designed to adapt to increasingly fluid living needs, it includes new elements such as the 45° inclined armchair — created to optimally support different seating positions — and deep modules, including the peninsula end unit and pouf, which broaden compositional possibilities.

These solutions enable articulated, multidirectional and highly customizable configurations, combining advanced ergonomics with a sophisticated aesthetic. Blisscape thus interprets the concept of contemporary comfort, transforming the sofa into a welcoming and central space within the living area.

Completing the system, Blisscape small tables further enhance its functionality, introducing a series of versatile elements designed to integrate seamlessly into compositions or to be used as independent pieces. Available in different shapes and sizes, they function as side tables, coffee tables or integrated surfaces, contributing to a dynamic and multifunctional living space.



Ludovica Serafini +
Roberto Palomba
Blisscape | Blisscape Deep



↑ ↗ **Blisscape Deep** sofa, Pelle Frau® ColorSphere® SC 34 Maggese
structure with cushions in Calyra Woven stone
Blisscape Low table 100x45, Pelle Frau® ColorSphere® SC 34 Maggese





↖ ↑ Blisscape Deep sofa, Pelle Frau® ColorSphere® SC 34 Maggese structure with cushions in fabric Velisse Moonstone



↑ ↗ Blisscape Deep sofa, Pelle Frau® ColorSphere® SC 34 Maggese structure with cushions in Calyra Woven stone
Blisscape Low table 150x40, Pelle Frau® ColorSphere® SC 34 Maggese



↗ Blisscape Low table 100x45, Pelle FrauR ColorSphereR SC 34 Maggese
↑ ↗ Blisscape Low Table 150x40 in Pelle Frau® ColorSphere® SC 34 Maggese



Blisscape small tables complete the system by expanding its functionality through a family of versatile elements, designed to integrate naturally into compositions or to stand as independent pieces.



Available in a variety of shapes and sizes, they can be used as side tables, coffee tables or integrated surfaces, helping to define a dynamic and multifunctional living environment.

Crafted from premium materials such as Pelle Frau® leather and marble, they express a refined balance between material richness, artisanal care and formal clarity. Paired with the sofa, they extend its usability with functional and aesthetically coherent surfaces; at the same time, thanks to their design autonomy, they can be freely placed in other areas of the home, engaging in dialogue with different furnishings while maintaining their distinctive identity.



Ludovica Serafini +
Roberto Palomba
Blisscape Low Table

↖ ↑ Blisscape Low round table Ø120, Pelle Frau® SC 178 Alpi with Ombra di Caravaggio marble top



↑ Blisscape Low table 100x100, Pelle Frau® SC 66 India

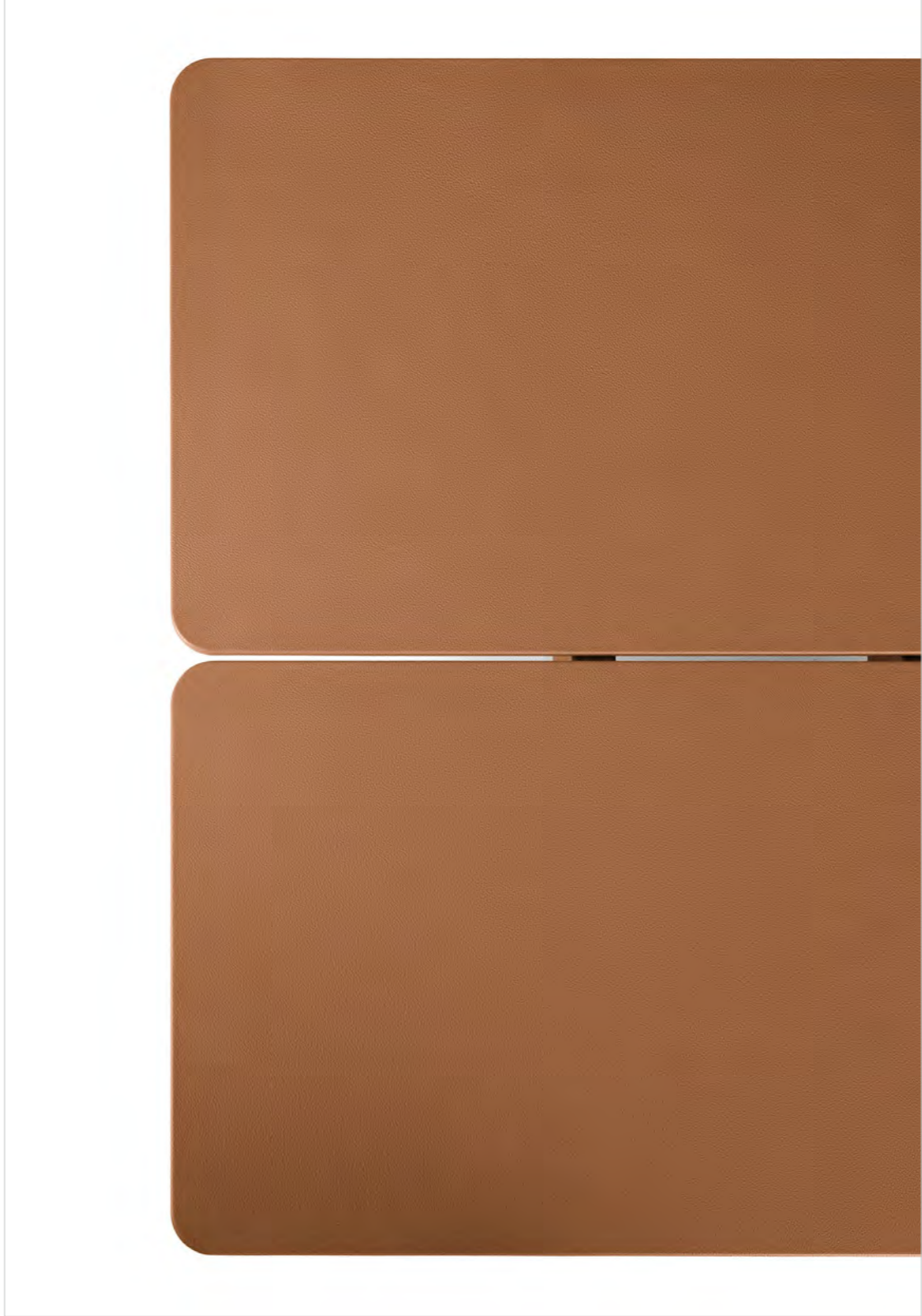

↑ Blisscape Low table 100x100, Pelle Frau® SC 66 India

Light and essential, the Archibald Slim Dining Chair reinterprets the iconic Archibald language in a more linear and versatile form.



The padded, enveloping backrest ensures comfort and proper support while maintaining a clean, contemporary aesthetic.

Ideal for dining settings as well as residential and contract environments, it is available in Pelle Frau® or fabric, with a solid ash wood base in various finishes.



Jean-Marie Massaud
Archibald Slim
Dining Chair



↖ ↑ Archibald Slim dining chair, Pelle Frau® SC 26 Topo with Moka ash legs

The Archibald Stool expands the collection with a swivel version that combines comfort and functionality.

Equipped with a 360° rotation mechanism with automatic return, it retains the elegant and enveloping lines of the Archibald family.

Available in two heights, with a solid ash wood base and stainless steel footrest, it can be upholstered in Pelle Frau® or fabric.



Jean-Marie Massaud
Archibald Stool
Wood swivel version

↖ ↑ Archibald Stool, Pelle Frau® SC 26 Topo with Moka ash legs



↑ Archibald Stool, Pelle Frau® SC 26 Topo with Moka ash legs.
Detail of the stainless steel footrest



↑ Archibald Stool, Pelle Frau® SC 26 Topo with Moka ash legs

An elegantly essential dining table, Abigail expresses a perfect balance between formal rigor and material richness.

The rectangular marble top, with softly rounded corners, is supported by four solid ash wood legs with a tapered triangular section, lending lightness to the overall design.

Available in three sizes, with a range of marble and wood finishes, Abigail adapts effortlessly to different dining settings, interpreting conviviality with a contemporary, timeless style.



↖ ↑ Abigail table 250×120, Arabescato Venato marble top with Moka ash base

Roberto Lazzeroni
Abigail



↖ ↑ Abigail table 250×120, Arabescato Venato marble top with Moka ash base

An evolution of the Infinito family, Infinitamente 2.0 is an extra large dining table that combines sculptural presence with a strong convivial spirit.



The marble top, composed of two offset ovals, evokes the symbol of infinity and the harmony of Yin and Yang, becoming a distinctive feature with both aesthetic and symbolic value.

The helical bases, upholstered in Pelle Frau® ColorSphere® Impact Less, express Poltrona Frau's craftsmanship excellence, enabling refined color combinations with the marble top.

Designed to host up to twelve people and available in a range of marble and leather finishes, Infinitamente 2.0 places the dining table at the center of contemporary living, blending material richness, technical precision, and timeless elegance.



↑ Infinitamente 2.0 table, Calacatta marble top with Pelle Frau® SC 66 India legs

Roberto Lazzeroni Infinitamente 2.0





↖ ↑ Infinitamente 2.0 table, Calacatta marble top with Pelle Frau® SC 66 India legs

A collection of geometric side tables defined by an essential and contemporary aesthetic.



Cuiré stands out for its balance between formal rigour and material richness, interpreting the table as a light yet distinctive architectural element.

The square shape, available in multiple sizes and a single height, is framed by a perimeter structure upholstered in Pelle Frau® leather, precisely outlining the top. Cylindrical legs, also leather-clad and finished with tone-on-tone stitching, create visual continuity and understated elegance.

The top is available in marble, crafted from a single slab, or in back-painted glass in Tortora, Qarzo Fumé, Creta, Limo and Steel Blue finishes, creating a refined dialogue between surfaces and colours, between leather and glass.

A design that combines geometry, materiality and sartorial craftsmanship, conceived to integrate seamlessly into a variety of interiors while enhancing the space with a sophisticated and balanced presence.



↖ ↑ Cuiré small table, Arabescato Venato marble top with Pelle Frau® SC 51 Panna feet

Poltrona Frau Style & Design Centre Cuiré



↖ ↑ Cuirè small table, Arabescato Venato marble top with Pelle Frau® SC 51 Panna feet

A special re-edition of the iconic Albero bookcase, Albero GFF 100 celebrates the centenary of Gianfranco Frattini's birth with a timeless design.



Originally conceived in the late 1950s as a floor-to-ceiling, freestanding room divider, it stands out for its self-supporting, rotating, and freely configurable structure.

Crafted in Santos rosewood and American walnut Brown, it showcases a refined material balance between rich grain patterns and deep tones. The twelve adjustable shelves and 360° rotation enhance both functionality and architectural presence.

The edition is distinguished by a commemorative brass plaque featuring the "GFF100" logo, paying tribute to a master of Italian design and to a project that retains its modernity over time.



Gianfranco Frattini Albero GFF100



↑ ↗ Albero GFF100 bookcase, American brown walnut structure with Santos Rosewood shelves



Designed by Dante Bonuccelli, DomusCove is a modular day system defined by architectural lightness and precision.



Poltrona Frau

Engineered for floor-to-ceiling or floor-to-wall installation, it enables the creation of flexible, free-standing or wall-mounted compositions.

Its modular structure allows for fully tailored configurations, adapting to a wide range of functional and aesthetic needs. Shelves, flap-door units, drawer modules and bar elements integrate into a dynamic system designed to organise and enhance the living space.

Premium materials such as wood, marble, glass and Pelle Frau® leather interact in a refined balance, expressing a synthesis of design versatility and artisanal craftsmanship. Details, finishes and customisation options define an elegant, contemporary system that evolves with the space.



Dante Bonuccelli DomusCove

↖ ↑ DomusCove living system – uprights and fronts of drawer chests and flap-door storage units in Pelle Frau® SC 66 India leather; Calacatta marble tops; bronzed glass shelves; Gold Walnut sides.

A project that combines
compositional freedom with formal
rigour, transforming furniture into
a bespoke domestic architecture.





↖ ↑ DomusCove living system – uprights and fronts of drawer chests and flap-door storage units in Pelle Frau® SC 66 India leather; Calacatta marble tops; bronzed glass shelves; Gold Walnut sides.

Zabriskie is a collection of storage units defined by clean, essential lines and a rigorous architectural language inspired by 1970s design.

Balanced proportions, suspended volumes and refined detailing create a sophisticated, contemporary presence.

Raised from the floor, each piece features a precise structure, Pelle Frau® leather upholstery and carefully crafted metal details. The top, available in wood or marble, introduces a refined contrast of materials, while interiors in extra-light natural maple enhance brightness and visual lightness.

The collection includes a range of configurations — low cabinets and multimedia cabinets — designed to meet different functional needs. Accessories and optional elements, such as internal drawers, dividers, trays and open shelves, allow for further customization.

Roberto Lazzeroni Zabriskie



↖ ↑ Zabriskie Low Cabinet 234X53 cm, Pelle Frau® SC 93 Brossura with Calacatta marble top

In the multimedia cabinet, integrated cable management solutions ensure optimal use of electronic devices while preserving a clean and orderly aesthetic.

A design that combines formal rigour, material refinement and compositional flexibility, conceived to organise space with elegance and precision.





↑ Zabriskie Low Cabinet 234X53 cm, Pelle Frau® SC 93 Brossura with Calacatta marble top

The Esedra collection, designed by Monica Förster, reinterprets the traditional pleating technique — an iconic element of Poltrona Frau craftsmanship — with a contemporary approach.

Poltrona Frau



The folds in Pelle Frau®, radiating from the center, create a refined sunburst pattern.

The range expands with new sizes and proportions, enhancing versatility of use. The more compact pouf, with a seat height similar to a chair, works perfectly as an additional seat at a table or desk, while the wider and lower version is designed for the living area, as an informal seat or footrest.

In the storage version, the pouf transforms into a small table thanks to a removable lid/tray, offering a practical space to store throws, cushions, or other objects.



↖ ↑ Esedra Medium with storage, Pelle Frau® SC 29 Ardesia
Esedra Small, Pelle Frau® Nest Cemento
Esedra Medium, Pelle Frau® SC 276 Mineral Blue

Monica Förster
Esedra



↑ Esdra Medium, Pelle Frau® SC 276 Mineral Blue



↑ Esdra Small, Pelle Frau® Nest Cemento
Esdra Medium, Pelle Frau® SC 276 Mineral Blue

A collection of poufs in essential square and rectangular forms, defined by clean, uninterrupted surfaces with no visible stitching.



Kubaya expresses a rigorous and contemporary aesthetic, designed to highlight the material quality and tactile richness of the upholstery.

At the heart of the collection is Pelle Frau® Motif Knits, created through a sophisticated hot-embossing process that generates a three-dimensional pattern inspired by textile weaves and basketry. The result is a rich, dynamic surface, soft and velvety to the touch, capable of enhancing light and colour nuances.

The collection is also available in other Pelle Frau® leathers, offering a range of material and colour interpretations.

Balanced proportions and compact volumes define versatile pieces that integrate naturally into a variety of interiors. The base is available with feet or with concealed swivel castors, ensuring flexibility of use.



Poltrona Frau Style & Design Centre Kubaya



↑ Kubaya pouf 86x61, Pelle Frau® Heritage Bronze



↑ Kubaya pouf 86x61, Pelle Frau® Motif Knits Cumin Dust

A generous, inviting bed, soft like a cloud, designed to envelop the body in a feeling of relaxed comfort.



Designed by Faye Toogood, LieLow is defined by its full, harmonious forms and gently draped upholstery that enhances its material richness.

The semi-circular headboard and bed frame are characterised by soft folds and generous volumes, evoking the elegance of a padded quilt. Upholstered in Pelle Frau® leather the surfaces naturally gather and crease, giving each piece a unique, expressive quality.

Resting lightly on its feet, LieLow appears almost to float, combining sculptural presence with visual softness. A design that reinterprets the bed as an intimate and welcoming space, blending expressiveness, comfort and contemporary refinement.



Faye Toogood LieLow





↑ LieLow bed, Pelle Frau® SC 26 Topo with leather back



↑ LieLow bed, Pelle Frau® SC 26 Topo

Designed by Faye Toogood, the LieLow bedside table is conceived as a natural extension of the bed, echoing its soft lines and enveloping silhouette.

A piece that dialogues with the original design, translating its language into a more compact scale.

The curved form recalls the profile of the headboard, while the Pelle Frau® leather upholstery follows the surfaces seamlessly, enhancing material richness and tactile quality. Tone-on-tone stitching and essential detailing contribute to a refined and understated aesthetic.

Available in a shelf or drawer version, the bedside table combines functionality with formal clarity. The drawer, defined by a subtle recessed front, features a push-pull opening system that preserves its clean appearance.

A piece designed to complete the bedroom with coherence and lightness, balancing comfort, craftsmanship and contemporary design.



↖ ↑ LieLow Bedside table, Pelle Frau® SC 05 Stucco

Faye Toogood LieLow Bedside table



Designed by Sebastian Herkner, Stock'N Roll evolves from a bedside table into a multifunctional piece, responding to the needs of contemporary living.



Poltrona Frau

156

A versatile design that can be configured as a sleek home desk or as a refined dressing table with an adjustable mirror.

Playful yet sophisticated, its compact volumes are defined by subtle circular details that shape its identity. Upholstered in Pelle Frau® ColorSphere® leather, inside and out — also available in a two-tone version — it enhances both material richness and colour depth.

Designed for everyday use, it features an organised storage compartment with shelves and tray, while the top includes an integrated oval valet tray. In the dressing table version, the adjustable mirror adds further functionality while maintaining formal coherence and visual lightness.

A piece that combines function and character, transforming everyday gestures into an elegant, contemporary experience.



↶ ↑ Stock'N Roll Dressing table, Pelle Frau® SC 66 India

Sebastian Herkner Stock'N Roll

True Over Time Collection

157

Stock'N Roll



↑ Stock'N Roll Home-desk, Pelle Frau® SC 66 India.
Detail of the storage compartment



↑ Stock'N Roll Home-desk, Pelle Frau® SC 66 India

Archibald Task President interprets the contemporary office through a balance of presence, comfort and wellbeing.



As the new executive chair in the Archibald Task collection, it evolves the family's iconic language with a higher, more enveloping backrest that extends seamlessly from the armrests, providing full support up to the head and enhancing posture and long-term comfort.

A defining feature is the innovative KristalMed® padding, a patented technology certified as a Class I Medical Device, integrating bio-molecules derived from natural minerals. Thanks to its bioactive properties, it promotes relaxation, improves concentration and supports wellbeing during long working hours.

The five-star aluminum base, available in polished or black painted finishes, incorporates advanced adjustment mechanisms for height, tilt and rotation. Upholstered in Pelle Frau® Impact Less or fabric, it is designed for contemporary office environments where ergonomics and design excellence come together in lasting comfort.



Jean-Marie Massaud Archibald Task President Chair



↑ Archibald Task President chair, Pelle Frau® SC 56 Siena with Black painted aluminum base, detail of the black painted base and wheels



↑ Archibald Task President chair, Pelle Frau® SC 56 Siena with Black painted aluminum base

The Tullissè table lamp is the result of a new collaboration with Atelier Oï. The result is both sophisticated and ethereal, reminiscent of the tulle tutu of a classical ballerina, which inspires the name Tullissè.

The Swiss multidisciplinary studio marks its first project with Poltrona Frau, reinterpreting the concept of the abat-jour in a contemporary way through an object that explores the interplay of light and shadow, expressing a new material and luminous language.

A refined spiral weave of Pelle Frau® leather strips forms a modern and distinctive lampshade, diffusing a soft, enveloping light. The leather shade rests on a structural glass element crafted using an artisanal technique: white at the top, it gradually fades into transparency towards the base, enhancing a captivating sense of lightness and magic. The lamp base is made of aluminium with a brass-painted finish.

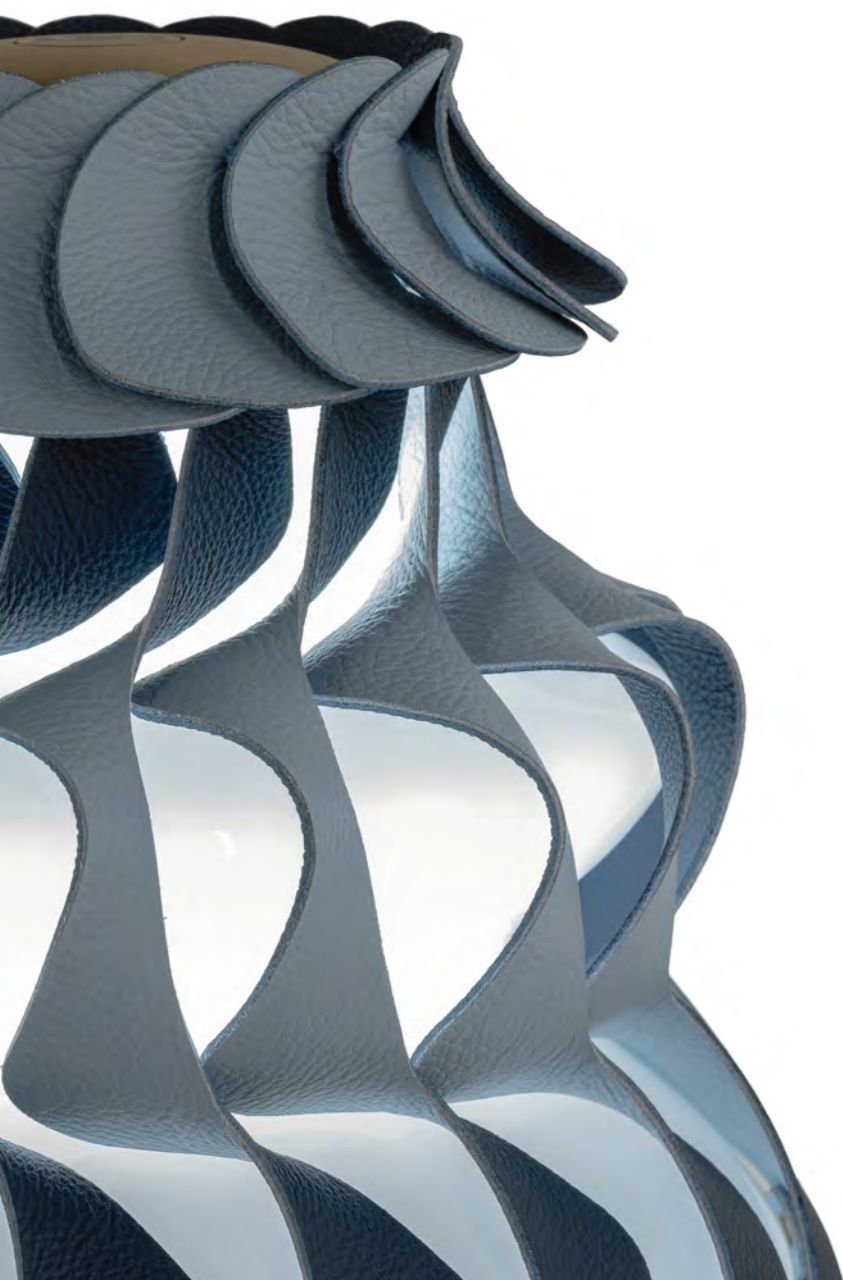

Atelier Oï
Tullissè

↶ ↑ Tullissè Medium Lamp, Pelle Frau® SC 278 Atlantic Blue and SC 233 Bardiglio

The lamp is available in two sizes and three colour combinations: red (Lacca/Smoked Quartz), brown-grey (India/Smoked Quartz), and blue-light blue (Atlantic Blue/Bardiglio).



↑ Tullissè Medium Lamp, Pelle Frau® SC 278 Atlantic Blue and SC 233 Bardiglio



↑ Tullissè Medium Lamp, Pelle Frau® SC 66 India and SC 31 Quarzo Fumè



↑ Tullissè Medium Lamp, Pelle Frau® SC 66 India and SC 31 Quarzo Fumè



↑ Tullissè Medium Lamp, Pelle Frau® SC 66 India and SC 31 Quarzo Fumè

More than a reissue, a true rediscovery:
Gio Ponti Oro is a floor lamp designed
by the Master in the 1950s for a residential
project and never put into production.



Today it is brought to light by Poltrona Frau in collaboration with the Gio Ponti Archives, as part of the "True Over Time" collection, dedicated to authentic design that endures over time.

Defined by a strong sculptural presence, the lamp stands out for its refined balance between form and light. Curved metal panels, arranged in a rhythmic sequence, interact with the vertical light tubes to create a dynamic, three-dimensional effect. The satin brass finish lends timeless elegance, enhancing the contrast between matte surfaces and luminous elements.

A project that embodies Gio Ponti's timeless vision and the enduring relevance of a design that remains strikingly modern across decades.



Gio Ponti Gio Ponti Oro



↑ Gio Ponti Oro floor lamp, detail of the satin brass finish base



The poetic essence of Moonbeam, winner of the Wallpaper* Design Awards 2026, expands into two new versions: an enlarged table lamp and a new floor variant.



Created in collaboration with digital artist Six N. Five (Ezequiel Pini) and presented at Milan Design Week 2025, the collection is enriched with a large table lamp and a floor version, expanding its versatility across residential and contract settings.

Inspired by the moon and its phases, Moonbeam stands out for its evocative, sculptural character. The new table version enhances its sense of refinement, while the floor lamp — ideal behind a sofa — creates the impression of light suspended in space, like a small floating moon. Refined proportions and detailing heighten its theatrical effect, reinforcing the collection's sophisticated identity.

Both the table and floor versions feature a brass finish, with a disc available in brass or Pelle Frau® ColorSphere Impact Less leather in Latte, Tortora, Mattone and Darsena.



↖ ↑ Moonbeam floor lamp, Pelle Frau® SC 04 Latte front disc

Six N.Five Moonbeam



↑ Moonbeam floor lamp, Pelle Frau® SC 04 Latte front disc





↑ Detail of the brass-galvanized aluminum base



↑ Moonbeam Large table lamp, Pelle Frau® SC 176 Darsena front disc
Moonbeam table lamp, Pelle Frau® SC 04 Latte front disc

Nymph by Sebastian Herkner is a suspended light defined by elegance and lightness.



↖ Nymph Air lamp, Fumè blown glass lampshade

Presented in 2024, the Nymph lamp series immediately stands out for its balanced interplay of refinement and simplicity. The collection is now expanded with a new pendant version: Nymph Air.

This new interpretation preserves the project's distinctive features: the fluted glass, inspired by one of Poltrona Frau's signature techniques, and the "button" detail applied to the lower part of the diffuser, recalling the iconic tufting of the Chester sofa.

In this version, a high-efficiency LED light bar interacts with the glass, casting a uniform, soft and enveloping light enriched by subtle transparencies. The effect is further enhanced by the introduction of a new white gradient glass, designed to create an even more evocative atmosphere.

The lighting body is completed by a height-adjustable suspension system, allowing for versatile integration in both residential and contract settings



↖ Nymph Air lamp, Satin milk white glass lampshade

Sebastian Herkner Nymph Air



↑ Nymph Air lamp, Fumè blown glass lampshade

An essential table, dressed with a few carefully chosen elements – both beautiful and functional. Chicware expresses Poltrona Frau's vision of a contemporary table setting, defined by balanced proportions, soft edges and refined detailing.

Placemat, napkin holder, charger and coaster: each piece is designed for everyday use, with durable surfaces that are pleasant to the touch. Pelle Frau® ColorSphere Impact Less leather adds visual depth, while the double-face construction allows for coordinated colour pairings, creating elegant contrasts or tone-on-tone harmonies.

Decorative double stitching and a hot-stamped logo provide a distinctive mark of authenticity and craftsmanship, for a collection designed to stand the test of time. The Chicware line is available in brown/grey and blue/light blue finishes.

Poltrona Frau Style & Design Centre Chicware



↑ Placemat, Pelle Frau® ColorSphere® SC 233 Bardiglio and SC 278 Atlantic Blue



↑ Coasters, Pelle Frau® ColorSphere® SC 66 India and SC 31 Quarzo Fumé



↑ Napkin Ring, Pelle Frau® ColorSphere® SC 66 India, SC 31 Quarzo Fumé, SC 233 Bardiglio and SC 278 Atlantic Blue

The Tableware Collection, created in collaboration between Poltrona Frau and Giobagnara, is enriched with new elements designed for elegant and functional serving.

Rectangular trays in three sizes, a basket with a stainless steel inner container, and a serving box with lid and glass divider complete the collection.

Each piece features a walnut wood structure covered in Pelle Frau® ColorSphere® leather, combining durability with refined aesthetics. The SC 66 India and SC 31 Quarzo Fumé finishes enhance the material depth, for a contemporary and sophisticated table setting.

Giobagnara x Poltrona Frau Tableware collection





↑ Rectangular trays, Pelle Frau® ColorSphere® SC 66 India and SC 31 Quarzo Fumé



Designed to accompany professional travel, the Traveller's Collection designed by Poltrona Frau combines functionality and elegance in a coordinated line featuring a trolley and a work bag. Each piece is conceived for everyday use, with a solid construction and an interior layout tailored to working on the move.



The trolley ensures smooth handling and stability thanks to its swivel wheels and practical access points, while the bag includes dedicated compartments for laptops and documents, with handles and a shoulder strap designed for comfort and durability. Pelle Frau® leather enhances the richness of texture and colour, while details are finished with sartorial precision.

The collection is available in Pelle Frau® ColorSphere in SC 20 Inchiostro and SC 66 India, or with the Motif Weavers pattern designed by Simona Cremascoli.



Poltrona Frau Style & Design Centre Traveller's Collection

Urban elegance.
 Ludovica Serafini + Roberto Palomba
 design a line of small leather goods
 conceived for dynamic urban mobility.
 Tote bag, beauty case and clutch pouch
 form a coordinated, functional and
 elegant set, complemented by a key
 holder and luggage tag.



↑ Clutch Pouch, Pelle Frau® Motif Weavers Cinnamon

Each piece is designed to be practical and durable: the tote is spacious and versatile, the beauty case keeps essentials organised, while the clutch stands out for its compact format. The woven Motif Weavers pattern designed by Simona Cremascoli defines the collection's identity, paired with clean proportions and refined detailing.

The result is a contemporary and sophisticated aesthetic that combines craftsmanship with an international sensibility, suitable for both travel and everyday use.



↑ Tote Bag, Pelle Frau® Motif Weavers Cinnamon

Ludovica Serafini + Roberto Palomba Traveller's Collection



↑ Luggage Tag, Pelle Frau® ColorSphere® SC 66 India and Motif Weavers Sage



↑ Leather Key Necklace, Pelle Frau® ColorSphere® SC 66 India

Carlotta Fortuna reinterprets the Traveller's Collection with an updated version of the backpack and travel bag, now enhanced by the woven Motif Weavers pattern designed by Simona Cremascoli.

Crafted in the Cinnamon colourway, both pieces combine functionality with a refined aesthetic, highlighting the material through a graphic and sophisticated design. The result is a balance of practicality and style, created to accompany contemporary travel with a distinctive character.

Carlotta Fortuna Traveller's Collection



An encounter between East and West gives life to Shiwa, a collection of ceramic vases designed by Japanese artist Yuki Nara.

Inspired by the ripples of water, the three models with organic shapes express a poetic and ever-evolving aesthetic.

Made of white clay using the slip casting technique, they are the result of artisanal processes that enhance the artist's hand and expertise. The surfaces, marked by gentle folds, evoke forms shaped by the wind.

After careful hand-finishing, each piece is completed with airbrushed glazing, enhancing its material depth.

Available in white and grey, the collection also includes the Tall Vase in Pacific Blue, a special limited-edition color.



Yuki Nara
Shiwa



↑ Shiwa Large Vase, White color



↑ Shiwa High Vase, Pacific Blue color

The Office Collection is expanded with two new accessories that combine practicality with refined detailing: a dual-compartment waste bin and a retractable tape measure.

The bin, defined by clean lines and softened edges, is made of wood covered in Pelle Frau® ColorSphere® leather, available in SC 66 India and SC 31 Quarzo Fumé finishes. The compact tape measure is also wrapped in Pelle Frau® leather and comes with a coordinated case, enhancing its character and making it ideal as a gift item.



Giobagnara x Poltrona Frau Office Collection

↑ Roller tape measure, Pelle Frau® ColorSphere® SC 66 India
↖ Double-compartment Caddy, Pelle Frau® ColorSphere® SC 66 India



↑ Double-compartment Caddy, Pelle Frau® ColorSphere® SC 66 India



↑ Roller tape measure, Pelle Frau® ColorSphere® SC 66 India

The Lifestyle Collection introduces a line of objects designed to organise personal accessories with elegance.

Jewellery and eyewear boxes, available with one or two compartments, open to reveal an integrated mirror and internal drawers with dividers.

The collection is completed by small valet trays, available in round or rectangular shapes and in two sizes, ideal for any area of the home. Crafted from walnut wood and covered in Pelle Frau® ColorSphere® leather, all pieces are available in SC 66 India e SC 31 Quarzo Fumé finishes.

Giobagnara
x Poltrona Frau
Lifestyle Collection



↖ ↑ Jewellery Vanity case, Pelle Frau® ColorSphere® SC 31 Quarzo Fumé
Eyewear case, Pelle Frau® ColorSphere® SC 66 India



↖ ↑ Round Small Valet tray, Pelle Frau® ColorSphere® SC 66 India



Translations

214 Italian translations

Indoor living

- 217 Abigail
- 217 Albero GFF100
- 218 Archibald Sofa System
- 221 Archibald Slim Dining Chair
- 221 Archibald | Stool Wood swivel version
- 222 Blisscape
- 224 Blisscape Deep
- 228 Blisscape Low Table
- 230 Cuiré
- 231 DomusCove
- 233 DressCove
- 235 Esedra
- 236 Infinitamente 2.0
- 236 Kubaya
- 237 LieLow
- 238 LieLow Bedside table
- 238 Stock'N Roll
- 239 Zabriskie

Work-Lab

241 Archibald Task | President Chair

Beautilities

Lamps

- 242 Gio Ponti Oro
- 242 Moonbeam
- 243 Nymph Air
- 243 Tullissè

Poltrona Frau, collezione 2026

IT
Con la collezione 2026, Poltrona Frau celebra un'idea di design autentico, capace di attraversare il tempo conservando intatto il proprio significato.
True Over Time racconta arredi pensati per durare, non solo nella qualità dei materiali e delle lavorazioni, ma nella loro capacità di evolvere insieme alla vita di chi li sceglie.

Un equilibrio tra tradizione artigianale, innovazione e responsabilità, in cui la durata diventa espressione di verità: oggetti che si trasformano, si arricchiscono e custodiscono nel tempo storie, gesti e memorie.

ABIGAIL
Design by Roberto Lazzeroni, 2026

Un tavolo da pranzo dall'eleganza essenziale, Abigail esprime un perfetto equilibrio tra rigore formale e matericità. Il piano rettangolare in marmo, dagli angoli smussati, è valorizzato da quattro gambe in massello di frassino dalla sezione triangolare, leggermente rastremate per conferire leggerezza all'insieme.

Disponibile in tre dimensioni, con diverse finiture di marmo e legno, Abigail si adatta con versatilità a molteplici ambienti dining, interpretando la convivialità con uno stile contemporaneo e senza tempo.

Poltrona Frau, collezione 2026

Poltrona Frau, collezione 2026

ALBERO GFF 100
Design by Gianfranco Frattini, 1958/2026
Riedizione speciale dell'iconica libreria Albero, Albero GFF 100 celebra il centenario dalla nascita di Gianfranco Frattini con un pezzo senza tempo. Progettata alla fine degli anni '50 come libreria centro stanza terra-soffitto, si distingue per la sua struttura autoportante, girevole e liberamente componibile. Realizzata in Palissandro Santos e Noce Americano Brown, esprime un raffinato equilibrio materico tra venature preziose e profondità cromatica. Le dodici mensole regolabili e la rotazione a 360° ne esaltano la funzionalità e la versatilità architettonica. L'edizione è impreziosita da una targhetta commemorativa in ottone con il logo "GFF100", omaggio a un maestro del design italiano e a un progetto capace di attraversare il tempo con intatta modernità.

ARCHIBALD SLIM DINING CHAIR
Design by Jean-Marie Massaud, 2026

Leggera ed essenziale, Archibald Slim Dining Chair reinterpreta l'iconico linguaggio Archibald in una versione più lineare e versatile. Lo schienale imbottito e avvolgente garantisce comfort e supporto, mantenendo un'estetica pulita e contemporanea.

Il design è disponibile in Pelle Frau® o tessuto, con base in frassino in diverse finiture.

Poltrona Frau, collezione 2026

ARCHIBALD SOFA SYSTEM
Design by Jean-Marie Massaud, 2026

Evoluzione dell'iconica poltrona Archibald, Archibald Sofa System traduce il linguaggio originario in un sistema modulare dalle proporzioni più ampie e accoglienti. Le forme morbide e avvolgenti, con schienali dalle linee tese e privi di cuscini aggiuntivi, sono animate dalle iconiche increspature e da cuciture ispirate alla pelletteria, segno distintivo del progetto.

Le sedute, concepite come elementi indipendenti, possono essere combinate liberamente in configurazioni lineari o angolari, offrendo grande flessibilità e adattabilità agli spazi contemporanei. I volumi, visivamente alleggeriti dai piedi nascosti, restituiscono un senso di sospensione ed eleganza.

Il sistema si completa con i tavolini Baldwin di Ceccotti Collezioni, caratterizzati da forme scultoree, piani in marmo e strutture in legno

massello, che dialogano armoniosamente con le curve morbide dei divani, arricchendo le composizioni con superfici funzionali e raffinate.

Il rivestimento è disponibile in Pelle Frau® o tessuto sfoderabile, sempre con base rivestita in Pelle Frau®, a sottolineare la continuità materica e l'attenzione al dettaglio.

ARCHIBALD | STOOL WOOD SWIVEL VERSION

Design by Jean-Marie Massaud, 2026

Lo sgabello Archibald amplia la collezione con una versione girevole che unisce comfort e funzionalità. Dotato di meccanismo di rotazione a 360° con ritorno automatico, mantiene le linee eleganti e avvolgenti della famiglia.

Disponibile in due altezze, con base in frassino e poggiapiedi in acciaio, è rivestito in Pelle Frau® o tessuto.

Poltrona Frau, collezione 2026

BLISSCAPE / BLISSCAPE DEEP
Design by Ludovica Serafini + Roberto Palomba

Il divano Blisscape evolve in una versione ancora più completa e confortevole, introducendo una nuova profondità di seduta, braccioli più alti e regolabili e un sistema modulare ulteriormente ampliato. Pensato per adattarsi a esigenze abitative sempre più fluide, integra nuovi elementi come la poltrona inclinata a 45°, progettata per sostenere in modo ottimale diverse posture, e i moduli deep, tra cui il terminale a penisola e il pouf, che ampliano le possibilità compositive. Queste soluzioni permettono di creare configurazioni articolate, multidirezionali e altamente personalizzabili, in grado di coniugare ergonomia avanzata e un'estetica sofisticata. Blisscape interpreta così il concetto di comfort contemporaneo, trasformando il divano in uno spazio accogliente e centrale nella zona living.

A completare il sistema, i tavolini Blisscape ampliano ulteriormente la funzionalità del divano, introducendo una serie di elementi versatili progettati per integrarsi armoniosamente nelle composizioni o vivere come pezzi indipendenti. Disponibili in diverse forme e dimensioni, si configurano come piani d'appoggio, coffee table o superfici integrate, contribuendo a definire uno spazio living dinamico e multifunzionale.

Poltrona Frau, collezione 2026

BLISSCAPE LOW TABLE
Design by Ludovica Serafini + Roberto Palomba

I tavolini Blisscape completano il sistema ampliandone la funzionalità attraverso una famiglia di elementi versatili, progettati per integrarsi con naturalezza nelle composizioni o vivere come pezzi indipendenti. Disponibili in diverse forme e dimensioni, si configurano come piani d'appoggio, coffee table o superfici integrate, contribuendo a definire uno spazio living dinamico e multifunzionale. Realizzati con materiali pregiati come la Pelle Frau® e il marmo, esprimono un equilibrio raffinato tra qualità materica, cura artigianale e rigore formale. Accostati al divano ne estendono le possibilità d'uso, offrendo superfici funzionali e coerenti dal punto di vista estetico; allo stesso tempo, grazie alla loro autonomia progettuale, possono essere inseriti liberamente anche in altri contesti della casa, dialogando con arredi diversi e mantenendo intatta la propria identità.

CUIRÉ

Design by Poltrona Frau

Style & Design Centre

Una collezione di tavolini geometrici dal segno essenziale e contemporaneo. Cuiré si distingue per l'equilibrio tra rigore formale e

ricchezza materica, interpretando il tavolino come un elemento architettonico leggero ma distintivo.

La forma quadrata, proposta in diverse dimensioni e in un'unica altezza, è definita da una cornice perimetrale rivestita in Pelle Frau® che disegna con precisione il profilo del piano. Le gambe cilindriche, anch'esse rivestite in pelle e rifinite con cuciture tono su tono, conferiscono continuità visiva ed eleganza discreta.

Il piano è disponibile in marmo, ricavato da un'unica lastra, oppure in vetro retro verniciato nelle finiture Tortora, Quarzo Fumé, Creta, Limo e Steel Blue, per un raffinato dialogo tra superfici e colori, tra pelle e vetro. Un progetto che unisce geometria, materia e cura sartoriale, pensato per inserirsi con naturalezza in diversi contesti abitativi, valorizzando lo spazio con una presenza sofisticata e misurata.

Poltrona Frau, collezione 2026

DOMUSCOVE
Design by Dante Bonuccelli

Disegnato da Dante Bonuccelli, DomusCove è un sistema giorno a montanti che interpreta lo spazio con leggerezza e precisione architettonica. Progettato per il fissaggio terra-soffitto o terra-parete, consente di creare composizioni libere e flessibili, sia a parete sia a centro stanza.

La struttura modulare permette di configurare soluzioni su misura, adattandosi a diverse esigenze funzionali ed estetiche. Ripiani, contenitori a ribalta, cassettiere e moduli bar si integrano in un sistema dinamico, pensato per organizzare e valorizzare la zona living. Materiali di pregio come legno, marmo, vetro e Pelle Frau® dialogano tra loro in un equilibrio raffinato, esprimendo una sintesi tra versatilità progettuale e cura artigianale. I dettagli, le finiture e le possibilità di personalizzazione definiscono un sistema elegante e contemporaneo, capace di evolversi insieme allo spazio.

Un progetto che coniuga libertà compositiva e rigore formale, trasformando l'arredo in un'architettura domestica su misura.

Poltrona Frau, collezione 2026

DRESSCOVE
Design by Dante Bonuccelli

Il sistema notte DressCove interpreta lo spazio guardaroba come un ambiente su misura, dove design, funzionalità e artigianalità si fondono in un equilibrio raffinato. Progettato da Dante Bonuccelli, rappresenta la prima soluzione completa Poltrona Frau per armadi e cabine armadio, pensata per creare configurazioni personalizzate fino al più piccolo dettaglio.

La struttura modulare consente di definire composizioni flessibili e altamente personalizzabili, mentre l'utilizzo di materiali pregiati — legni, metalli e Pelle Frau® — esprime una sintesi tra innovazione e tradizione manifatturiera. Ogni elemento è studiato per coniugare precisione progettuale ed eleganza senza tempo.

Le novità introducono ulteriori possibilità espressive: nuove finiture, accessori e dettagli arricchiscono il sistema, ampliandone la versatilità. Completa il progetto la possibilità di integrare un dressing table dedicato, perfettamente coordinato e armoniosamente inglobato nella composizione. Un sistema che trasforma il guardaroba in uno spazio intimo e sofisticato, dove ogni gesto quotidiano diventa espressione di stile e cura.

ESEDRA

Design by Monica Förster, 2026

La collezione Esedra, firmata da Monica Förster, reinterpreta in chiave contemporanea la tradizionale lavorazione plissé, cifra

distintiva Poltrona Frau. Le pieghe in Pelle Frau®, che si irradiano dal centro, creano un raffinato motivo a raggiara.

La gamma si amplia con nuove dimensioni e proporzioni, per una maggiore versatilità d'uso. Il pouf più compatto, con altezza simile a una sedia, è ideale come seduta aggiuntiva anche davanti a tavoli o scrivanie; quello più ampio e basso è pensato per il living, come seduta informale o poggiapiedi. Nella versione con contenitore, il pouf si trasforma in tavolino grazie a un coperchio/vassoio removibile, offrendo uno spazio pratico per riporre oggetti.

Poltrona Frau, collezione 2026

INFINITAMENTE 2.0
Design by Roberto Lazzeroni, 2026

Evoluzione della famiglia Infinito, Infinitamente 2.0 è un tavolo da pranzo dalle proporzioni extra large che unisce forza scultorea e vocazione conviviale. Il piano in marmo, composto da due ovali sfalsati, richiama il simbolo dell'infinito e l'armonia dello Yin e Yang, trasformandosi in un segno distintivo di grande valore estetico e simbolico. Le basi elicoidali, rivestite in Pelle Frau® ColorSphere® Impact Less, esprimono l'eccellenza del savoir-faire artigianale Poltrona Frau, con lavorazioni raffinate che permettono eleganti combinazioni cromatiche con il top in marmo.

Pensato per accogliere fino a dodici persone e disponibile in diverse finiture di marmo e pelle, Infinitamente 2.0 interpreta la tavola come fulcro della convivialità contemporanea, con un linguaggio progettuale che coniuga materia, tecnica e un'eleganza senza tempo.

Poltrona Frau, collezione 2026

KUBAYA
Design by Poltrona Frau Style & Design Centre

Una collezione di pouf dalle forme essenziali, quadrate e rettangolari, caratterizzata da superfici pulite e continue, prive di cuciture a vista. Kubaya esprime un'estetica rigorosa e contemporanea, pensata per mettere in risalto la matericità e il valore tattile del rivestimento.

Protagonista è la Pelle Frau® Motif Knits, ottenuta attraverso un sofisticato processo di embossing a caldo che crea un motivo tridimensionale ispirato agli intrecci tessili e alla cesteria. Il risultato è una superficie ricca e dinamica, morbida e vellutata al tatto, capace di valorizzare la luce e le sfumature del colore.

La collezione è disponibile anche in altre pelli Pelle Frau®, offrendo diverse interpretazioni materiche e cromatiche del progetto. Le proporzioni equilibrate e i volumi compatti definiscono oggetti versatili, pensati per inserirsi con naturalezza in diversi contesti abitativi. Il basamento è disponibile con piedini oppure con ruote piroettanti integrate, per una maggiore flessibilità d'uso.

Poltrona Frau, collezione 2026

LIELOW
Design by Faye Toogood

Un letto ampio e accogliente, soffice come una nuvola, pensato per avvolgere il corpo in una sensazione di comfort rilassato. Disegnato da Faye Toogood, Lielow si distingue per le sue forme piene e armoniose e per un rivestimento delicatamente drappeggiato che ne esalta la matericità.

La testata semicircolare e il giroletto si caratterizzano per morbide pieghe e volumi generosi, evocando l'eleganza di una trapunta imbottita. Il rivestimento in Pelle Frau® accompagna naturalmente le superfici, creando un effetto leggermente increspato che rende ogni pezzo unico.

Sospeso sui suoi piedini, Lielow appare leggero e quasi fluttuante, combinando presen-

za scultorea e comfort visivo. Un progetto che interpreta il letto come spazio intimo e accogliente, capace di unire espressività, morbidezza e raffinatezza contemporanea.

Poltrona Frau, collezione 2026

LIELOW BEDSIDE TABLE

Design by Faye Toogood

Disegnato da Faye Toogood, il comodino Lielow nasce come naturale estensione del letto, riprendendone le linee morbide e la silhouette avvolgente. Un complemento che dialoga con il progetto originale, traducendone il linguaggio in una scala più compatta. La forma curva richiama il profilo della testata, mentre il rivestimento in Pelle Frau® segue le superfici con continuità, esaltando la matericità e la qualità tattile. Le cuciture tono su tono e i dettagli essenziali contribuiscono a un'estetica sobria e raffinata. Disponibile nella versione con mensola o con cassetto, il comodino unisce funzionalità e pulizia formale. Il cassetto, caratterizzato da una delicata rientranza frontale, integra un'apertura push-pull che ne mantiene l'aspetto minimale.

Un oggetto pensato per completare lo spazio notte con coerenza e leggerezza, in perfetto equilibrio tra comfort, artigianalità e design contemporaneo.

Poltrona Frau, collezione 2026

STOCK'N ROLL
Design by Sebastian Herkner

Disegnato da Sebastian Herkner, Stock'n Roll si evolve da comodino a elemento multifunzionale, capace di interpretare le esigenze dell'abitare contemporaneo. Un progetto versatile che può essere configurato come home desk essenziale oppure come raffinata toaletta con specchio orientabile. Il design, giocoso ma sofisticato, è caratterizzato da volumi compatti e dettagli circolari che ne definiscono l'identità. Il rivestimento in Pelle Frau® ColorSphere® avvolge superfici interne ed esterne, anche in versione bicolore, valorizzando la profondità cromatica e la qualità materica.

Pensato per un utilizzo quotidiano, integra uno spazio contenitore organizzato con ripiani e vassoio, mentre il top è arricchito da un pratico vuotatasche integrato. Nella versione toaletta, lo specchio regolabile introduce un ulteriore elemento funzionale, mantenendo coerenza formale e leggerezza visiva.

Un oggetto che unisce funzionalità e carattere, trasformando i gesti quotidiani in un'esperienza elegante e contemporanea.

ZABRISKIE

Design by Roberto Lazzeroni

Zabriskie è una collezione di contenitori dal linguaggio essenziale e rigoroso, ispirata a un'estetica architettonica che richiama gli anni '70. Linee pulite, proporzioni equilibrate e volumi sospesi definiscono una presenza sofisticata e contemporanea.

Completano la collezione piccoli vassoi vuotatasche, disponibili in forma tonda o rettangolare il carattere. Il top, disponibile in legno o in marmo, introduce un raffinato contrasto materico, mentre gli interni in acero naturale extrachiaro aggiungono luminosità e leggerezza visiva.

La collezione comprende diverse configurazioni — low cabinet e multimedia cabinet — pensate per rispondere a esigenze funzionali differenti. Accessori e optional, come cassette interni, divisorii, vassoi e mensole a giorno, permettono di personalizzare ulteriormente ogni composizione. Nel multimedia cabinet, l'integrazione di sistemi per la gestione dei cavi consente un utilizzo ottimale dei dispositivi elettronici, mantenendo pulizia formale e ordine visivo.

Un progetto che unisce rigore formale, ricerca materica e flessibilità progettuale, pensato per organizzare lo spazio con eleganza e precisione.

Poltrona Frau, collezione 2026

ARCHIBALD TASK | PRESIDENT CHAIR

Design by Jean-Marie Massaud, 2026

Archibald Task President interpreta l'ufficio contemporaneo con un equilibrio tra rappresentatività, comfort e benessere. Nuova poltrona presidenziale della collezione Archibald Task, evolve l'iconico linguaggio della famiglia con uno schienale più alto e avvolgente che, in continuità con i braccioli, offre un sostegno completo fino alla nuca, valorizzando postura e comfort prolungato. Elemento distintivo è l'innovativa imbottitura Kristal Med®, tecnologia brevettata e certificata come Dispositivo Medico di Classe I, che integra bio-molecole derivate da minerali naturali. Grazie alle sue proprietà bioattive, favorisce il rilassamento, migliora la concentrazione e contribuisce al benessere durante lunghe ore di lavoro.

La base a cinque razze in alluminio, disponibile nelle finiture lucida o verniciata nera, integra meccanismi di regolazione avanzati per altezza, inclinazione e rotazione. Il rivestimento in Pelle Frau® Impact Less o tessuto completa una seduta pensata per ambienti office evoluti, dove ergonomia e qualità progettuale si fondono in un'esperienza di comfort duraturo.

Poltrona Frau, collezione 2026

GIO PONTI ORO

Design by Gio Ponti, 1950

Più che una riedizione, una vera e propria riscoperta: Gio Ponti Oro è una lampada da terra progettata dal Maestro negli anni '50 per un progetto residenziale e mai entrata in produzione. Oggi viene riportata alla luce da Poltrona Frau in collaborazione con Gio Ponti Archives, all'interno della collezione "True Over Time", dedicata a un design autentico e capace di attraversare il tempo. Caratterizzata da una forte presenza scultorea, la lampada si distingue per l'equilibrio raffinato tra forma e luce. I pannelli metallici curvi, disposti in sequenza ritmica, dialogano con i tubi luminosi verticali creando un effetto dinamico e tridimensionale. La finitura in ottone satinato conferisce eleganza e profondità, esaltando il contrasto tra superfici opache e sorgenti luminose.

Un progetto che testimonia la visione senza tempo di Gio Ponti e il valore di un design che, anche a distanza di decenni, conserva intatta la propria modernità.

Poltrona Frau, collezione 2026

LIFESTYLE COLLECTION

Design by Giobagnara x Poltrona Frau

La Lifestyle Collection introduce una linea di oggetti pensati per organizzare con eleganza gli accessori personali. Portagioielli e porta occhiali, disponibili a uno o due scomparti, si aprono rivelando uno specchio integrato e cassette interni suddivisi. Completano la collezione piccoli vassoi vuotatasche, disponibili in forma tonda o rettangolare e in due dimensioni, ideali per ogni ambiente della casa. Realizzati in legno di noce e rivestiti in Pelle Frau® ColorSphere®, gli oggetti sono disponibili nelle finiture SC 66 India e SC 31 Quarzo Fumé.

MOONBEAM

Design by Six N.Five, 2026

La poesia di Moonbeam, vincitrice dei Wallpaper* Design Awards 2026, si estende a due nuove versioni, una da tavolo di dimensioni maggiorate e una nuova variante da terra. Nata dalla collaborazione con l'artista digitale Six N. Five (Ezequiel Pini) e presentata alla Milano Design Week 2025, la collezione si arricchisce con una lampada da tavolo

Large e una versione da terra, ampliando le possibilità d'uso in contesti residenziali e contract.

Ispirata alla luna e alle sue fasi, Moonbeam si distingue per il suo carattere evocativo e scultoreo. La nuova versione da tavolo ne accentua la preziosità, mentre la lampada da terra — ideale dietro un divano — crea l'effetto di una luce sospesa, come una piccola luna in equilibrio nello spazio. Proporzioni e dettagli ricercati esaltano l'effetto scenografico, rafforzando il carattere sofisticato della collezione.

Sia la versione da tavolo che quella da terra, sono in finitura ottone, con disco disponibile in ottone o in Pelle Frau® ColorSphere Impact Less nelle tonalità Latte, Tortora, Mattone e Darsena.

Poltrona Frau, collezione 2026

NYMPH AIR

Design by Sebastian Herkner, 2026

Nymph by Sebastian Herkner è una luce sospesa tra eleganza e leggerezza. Presentata nel 2024, la serie di lampade Nymph si distingue fin da subito per il suo equilibrio misurato tra raffinatezza e semplicità. La collezione si arricchisce oggi di una nuova versione a sospensione: Nymph Air. Questa nuova interpretazione mantiene intatti i tratti distintivi del progetto: il vetro lavorato a canneté, ispirato a una delle lavorazioni iconiche di Poltrona Frau, e il dettaglio del "bottono" applicato nella parte inferiore, che richiama la tradizionale impuntura del divano Chester.

In questa configurazione, una barra LED ad alta efficienza dialoga con il vetro, diffondendo una luce uniforme, morbida e avvolgente, ricca di trasparenza. L'effetto è ulteriormente esaltato dall'introduzione di un nuovo vetro sfumato bianco, pensato per rendere l'atmosfera ancora più suggestiva. Il corpo illuminante è completato da un sistema di sospensione regolabile in altezza, che consente un'integrazione versatile in ambienti residenziali e contract. La lampada a sospensione Nymph Air è disponibile in due finiture — vetro fumé e vetro sfumato bianco — e in due dimensioni.

Poltrona Frau, collezione 2026

OFFICE COLLECTION

Design by Giobagnara x Poltrona Frau

La Office Collection si amplia con due nuovi accessori che uniscono praticità e cura del dettaglio: un cestino a doppio scomparto e un metro a nastro retrattile.

Il cestino, dalle linee essenziali e dagli angoli smussati, è realizzato in legno rivestito in Pelle Frau® ColorSphere®, disponibile nelle finiture SC 66 India e SC 31 Quarzo Fumé. Il metro tascabile, compatto e funzionale, è rivestito in Pelle Frau® e accompagnato da un astuccio coordinato, che ne valorizza il carattere e lo rende ideale anche come oggetto regalo.

SHIWA

Design by Yuki Nara, 2026

Un incontro tra Oriente e Occidente dà vita a Shiwa, collezione di vasi in ceramica firmata dall'artista giapponese Yuki Nara. Ispirati alle increspature dell'acqua, i tre modelli dalle forme organiche esprimono un'estetica poetica e in continua trasformazione. Realizzati in terra bianca con la tecnica del colaggio, nascono da processi artigianali che valorizzano la mano e la competenza dell'artista. Le superfici, segnate da leggere pieghe, evocano forme mosse dal vento. Dopo la levigatura manuale, ogni pezzo è rifinito con smaltatura ad aerografo, esaltandone la profondità materica. Disponibili in bianco e grigio, sono affiancati dal Vaso Alto in Blu Pacifico, colore speciale in edizione limitata.

TABLEWARE COLLECTION

Design by Giobagnara x Poltrona Frau

La Tableware Collection nasce dalla collaborazione tra Poltrona Frau e Giobagnara e si arricchisce di nuovi elementi pensati per un servizio elegante e funzionale. Vassoi rettangolari in tre dimensioni, un cestino con contenitore interno in acciaio inox e un contenitore da portata con coperchio e divisorio in vetro completano la collezione.

Ogni oggetto è caratterizzato da una struttura in legno di noce rivestita in Pelle Frau® ColorSphere®, che unisce solidità e raffinatezza. Le finiture SC 66 India e SC 31 Quarzo Fumé esaltano la profondità materica, per una mise en place contemporanea e ricercata.

Poltrona Frau, collezione 2026

CHICWARE

Design by Poltrona Frau Style & Design

Una tavola essenziale, vestita con pochi elementi, belli e funzionali. Chicware interpreta la visione Poltrona Frau di un'apparecchiatura contemporanea, fatta di proporzioni equilibrate, bordi morbidi e dettagli curati. Tovaglietta, portatovagliolo, sottopiatto e sottobicchiere: ogni elemento è progettato per l'uso quotidiano, con superfici resistenti e piacevoli al tatto. La Pelle Frau® ColorSphere Impact Less dona profondità visiva, mentre la lavorazione double-face consente di abbinare due colori coordinati, creando contrasti eleganti o armonie tono su tono. La doppia cucitura decorativa e il logo impresso a caldo aggiungono un segno distintivo di autenticità e pregio, per una collezione pensata per durare nel tempo. La linea Chicware è disponibile nelle finiture marrone/grigio e blu/azzurro.

Poltrona Frau, collezione 2026

TULLISSÉ
Design by Atelier Oï, 2026

La lampada da tavolo Tullissé nasce da una nuova collaborazione con Atelier Oï. Lo studio svizzero multidisciplinare firma il suo primo progetto per Poltrona Frau, reinterpretando l'idea di abat-jour in chiave contemporanea attraverso un oggetto che esplora il rapporto tra luce e ombra, dando vita a un inedito linguaggio materico e luminoso. Un raffinato intreccio a spirale di strisce di Pelle Frau® dà forma a un paralume moderno e originale, capace di diffondere una luce morbida e avvolgente. Il paralume in pelle si posa su un vetro strutturale realizzato con una tecnica artigianale: bianco nella parte superiore, sfuma progressivamente verso la trasparenza, amplificando un suggestivo effetto di leggerezza e magia. La base è in alluminio con finitura verniciata ottone.

Il risultato è al tempo stesso sofisticato ed etereo, evocando il tutù in tulle di una ballerina classica, da cui prende ispirazione il nome Tullissé. La lampada è disponibile in due dimensioni e in tre varianti colore: rosso (Lacca/Quarzo Fumé), marrone-grigio (India/Quarzo Fumé) e blu-azzurro (Atlantic Blue/Bardiglio).

Poltrona Frau, collezione 2026

TRAVELLER'S COLLECTION

Design by Poltrona Frau

Style & Design Centre

Pensata per accompagnare gli spostamenti professionali, la Traveller's Collection disegnata da Poltrona Frau unisce funzionalità ed eleganza in una linea coordinata composta da trolley e borsa da lavoro. Ogni elemento è progettato per l'uso quotidiano, con una costruzione solida e un'organizzazione interna studiata per il lavoro in viaggio. Il trolley si distingue per maneggevolezza e stabilità, grazie alle ruote piroettanti e agli accessi funzionali, mentre la borsa integra spazi dedicati a laptop e documenti, con manici e tracolla progettati per garantire comfort e resistenza. Le superfici in Pelle

Frau® valorizzano la grana e la profondità cromatica, mentre i dettagli sono rifiniti con cura sartoriale.

La collezione è disponibile in Pelle Frau® ColorSphere nelle tonalità SC 20 Inchiostro e SC 66 India, oppure con il pattern Motif Weavers ideato da Simona Cremascoli.

TRAVELLER'S COLLECTION

Design by Ludovica Serafini

+ Roberto Palomba

Eleganza urbana. Ludovica Serafini + Roberto Palomba firmano una linea di piccola pelletteria pensata per una mobilità urbana dinamica. Tote bag, beauty case e clutch pouch compongono un set coordinato funzionale ed elegante, completato da portachiavi e luggage tag.

Ogni elemento è progettato per essere pratico e resistente: la tote bag è capiente e versatile, il beauty case custodisce gli essenziali, mentre la clutch si distingue per il formato compatto. Il pattern intrecciato Motif Weavers ideato da Simona Cremascoli definisce l'identità della collezione, dialogando con proporzioni pulite e dettagli accurati.

Il risultato è un'estetica contemporanea e raffinata, che unisce artigianalità e gusto internazionale, adatta al viaggio come all'uso quotidiano.

TRAVELLER'S COLLECTION

Design by Carlotta Fortuna

Carlotta Fortuna rinnova la Traveller's Collection con una nuova interpretazione dello zaino e della borsa da viaggio, introdotti in una versione arricchita dal pattern intrecciato Motif Weavers.

Realizzati nella tonalità Cinnamon, i due accessori combinano funzionalità e ricerca estetica, valorizzando la materia attraverso un disegno grafico e sofisticato. Il risultato è un equilibrio tra praticità e stile, pensato per accompagnare il viaggio contemporaneo con carattere distintivo.

A

Please note:
this catalogue shows only some technical drawings, in order to know all the availabilities please refer to the current price list.

Abigail — Table 180×95

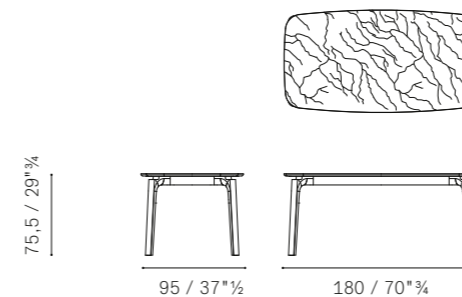

Abigail

Designed by Roberto Lazzeroni

Items.

- 180×95
- 220×120
- 250×120

Base.

- Solid wood available in two finishes:
- Ash in a wenge stain (32)
 - Ash in a moka stain (61)

Top.

- Available in:
- Brilliant Calacatta marble
 - Semi-brilliant Calacatta marble
 - Calacatta marble with natural glossy finish
 - Brilliant Arabescato marble
 - Semi-brilliant Arabescato marble
 - Arabescato marble with natural glossy finish
 - Brilliant Bianco (white) Carrara marble
 - Semi-brilliant Bianco (white) Carrara marble
 - Bianco (white) Carrara marble with natural glossy finish

Aesthetic details. Exposed structural metal parts in black-painted steel.

Abigail — Table 220×120

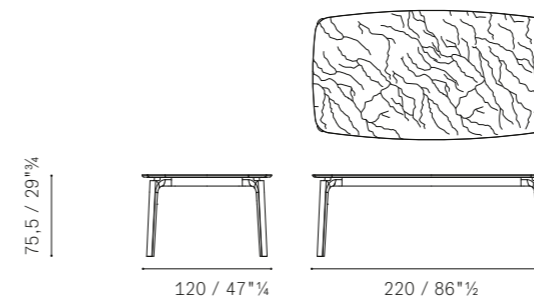

Abigail — Table 250×120

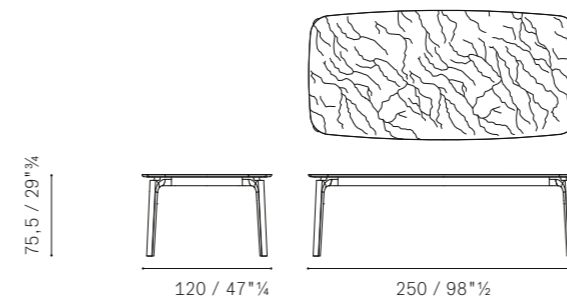

Albero GFF100 — Bookcase

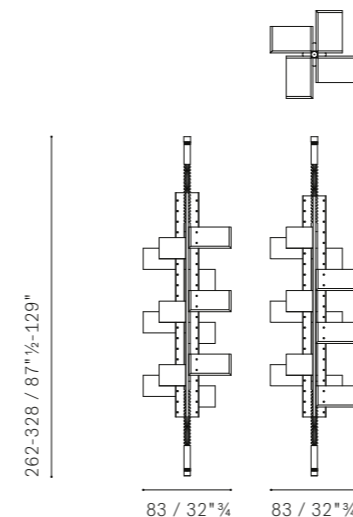

Albero GFF100

Designed by Gianfranco Frattini, 1958/2026

Supporting structure. Made of solid American walnut Brown.

Shelves. In Santos rosewood.

Screws. Made of antiqued brass.

Rotation. The bookcase can be turned 360° around its axis.

Aesthetic details. An antiqued brass plaque is applied to the lower toothed upright, bearing the Anniversary edition name, the designer's signature, and the Poltrona Frau logo.

OPTIONAL ACCESSORIES

Saddle-leather pad. The top of the shelves can be embellished and protected by a Cuocio Saddle Extra leather pad.

Please note:
this catalogue shows only some technical drawings, in order
to know all the availabilities please refer to the current price list.

Archibald Sofa System — 2-Seater Sofa

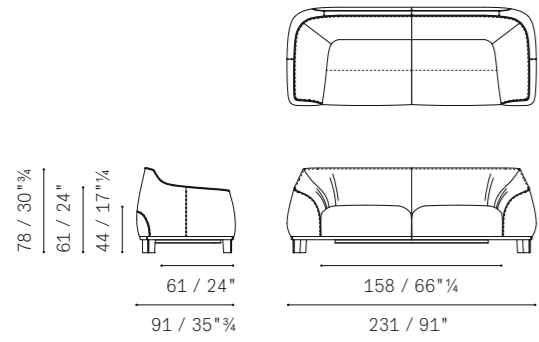

Archibald Sofa System — Sectional 2-Seater Sofa

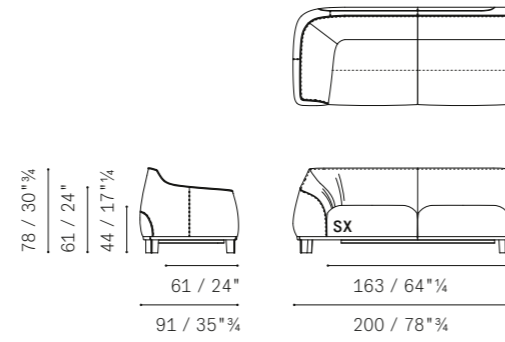

Archibald Sofa System — Corner 2-Seater Sofa

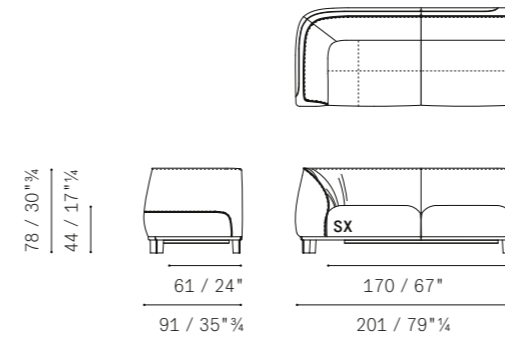

Archibald Sofa System — Corner 2-Seater Sofa with arm

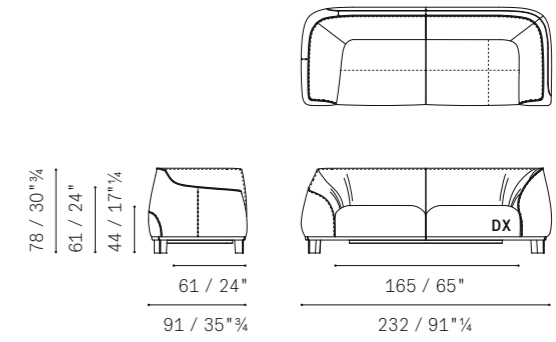

Archibald Sofa System — Large 2-Seater Sofa

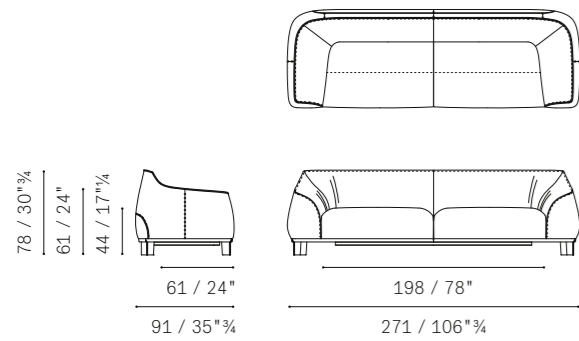

Archibald Sofa System — Sectional large 2-Seater Sofa

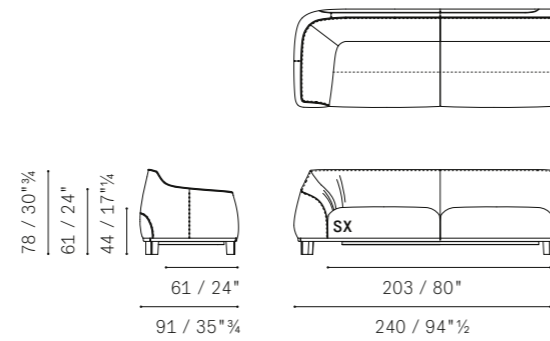

Archibald Sofa System — Corner large 2-Seater Sofa

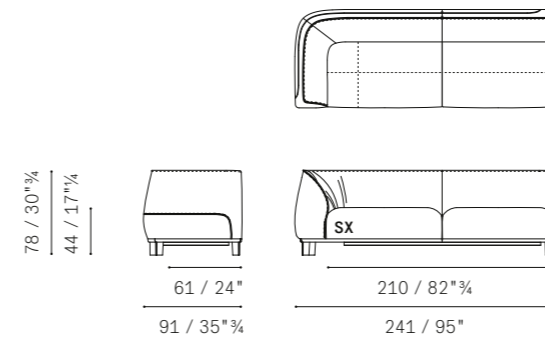

Archibald Sofa System — Corner large 2-Seater Sofa with arm

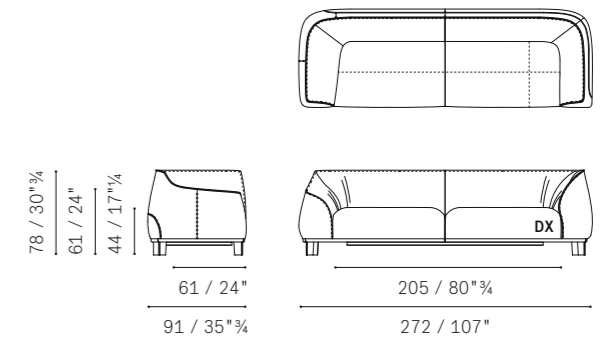

Archibald Sofa System — 3-Seater Sofa

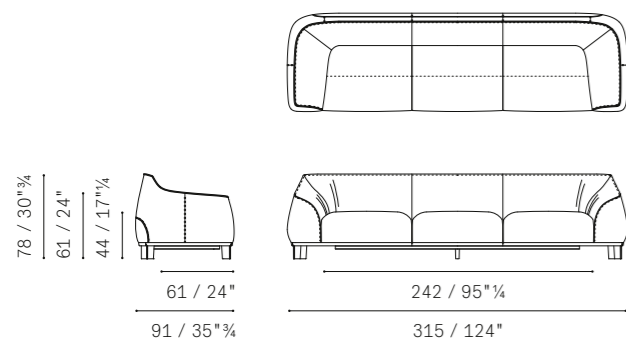

Archibald Sofa System — Sectional 3-Seater Sofa

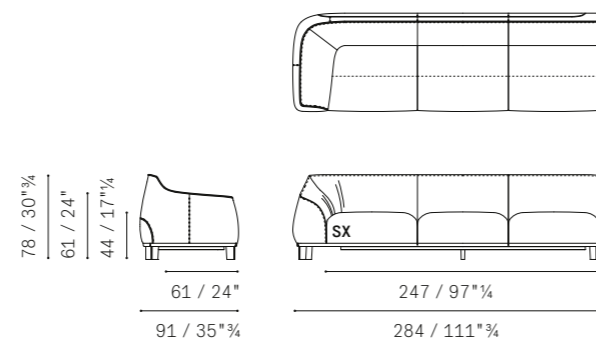

Archibald Sofa System — Corner 3-Seater Sofa

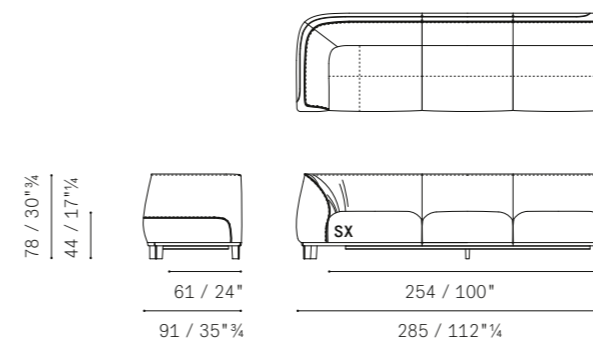

Archibald Sofa System — Corner 3-Seater Sofa with arm

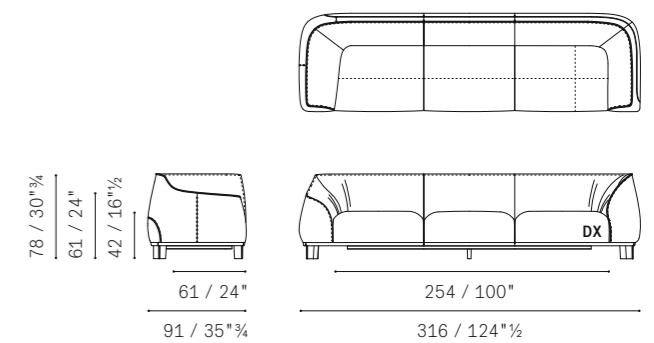

Archibald Sofa System — Ottoman

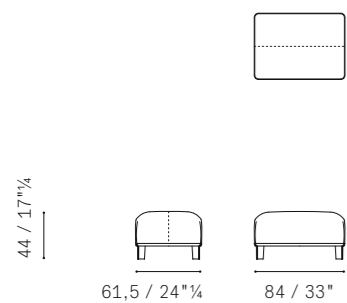

Archibald Sofa System — Large ottoman

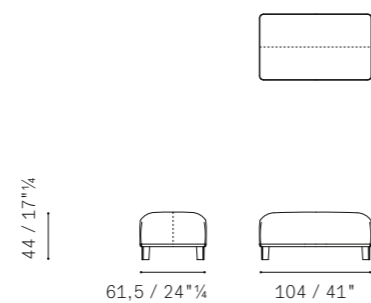

Archibald Sofa System — Chaise longue

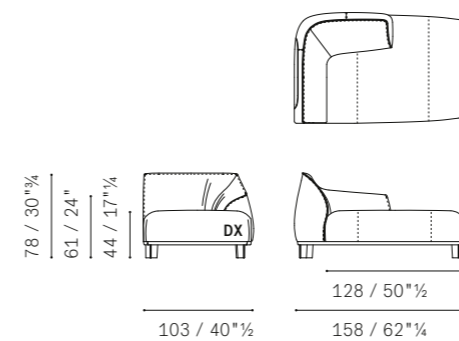

Archibald Sofa System — Layout example 01

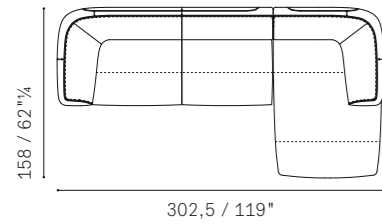

Archibald Sofa System — Layout example 02

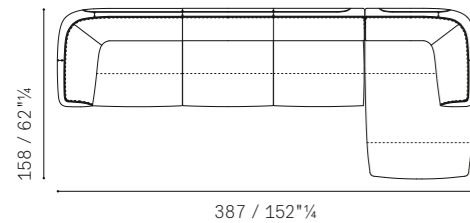

Archibald Sofa System — Layout example 03

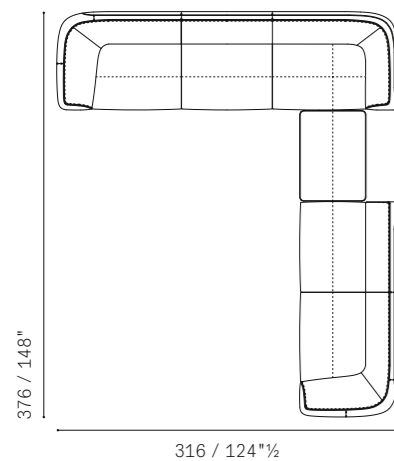

Archibald Sofa System

Design Jean-Marie Massaud, 2026

Seat cushion.

- "Soft comfort", with polyester padding and polyurethane foam in different densities, including viscoelastic foam.
- "Firm comfort", with polyester padding and polyurethane foam in different densities, including high-tech foam and viscoelastic foam.

Feet. Made of solid ash wood in the following finishes:

- Moka-stained ash
- Wenge-stained ash
- or (WITH SURCHARGE) in die-cast zamak with the following finishes:
- Gunmetal
- Burnished
- Titanium

Upholstery. Entirely in Pelle Frau® (including bicolor options) or in combinations of different materials. The first upholstery is applied to the sofa (seat, backrest and armrests), while the secondary upholstery is applied to the under-seat frame.

- ColorSphere® (SC)*
- Nest*
- Heritage
- Soulful
- Velvety
- Fabric A / ColorSphere® (SC)
- Fabric A / Heritage
- Fabric A / Nest
- Fabric A / Soulful
- Fabric B / ColorSphere® (SC)
- Fabric B / Heritage
- Fabric B / Nest
- Fabric B / Soulful
- Fabric C / ColorSphere® (SC)
- Fabric C / Heritage
- Fabric C / Nest
- Fabric C / Soulful
- C.O.M. / ColorSphere® (SC)
- C.O.M. / Heritage
- C.O.M. / Nest
- C.O.M. / Soulful

Stitching. Tone-on-tone.

Please note:
this catalogue shows only some technical drawings, in order
to know all the availabilities please refer to the current price list.

Archibald Slim Dining Chair — Leather upholstery

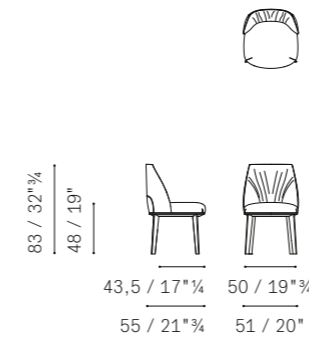

Archibald Slim Dining Chair — Fabric upholstery

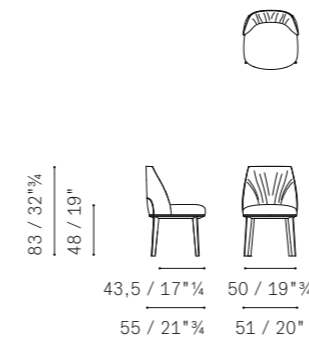

Archibald | Stool Wood swivel version — Swivel stool h 66

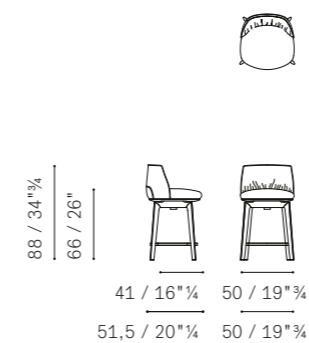

Archibald | Stool Wood swivel version — Swivel stool h 75

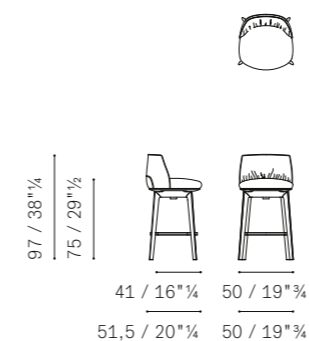

Archibald Slim Dining Chair

Design Jean-Marie Massaud, 2026

Wood base. The seat base and legs are available in two kinds of solid wood:

- Ash in a wenge stain (32)
- Ash in a moka stain (61)
- Additional special finishes available at extra cost:
- Ash stained, as per sample
- RAL lacquered ash, as per sample.

Upholstery.

- ColorSphere® (SC)
- Nest
- Soulful
- Fabric A
- Fabric B
- Fabric C
- C.O.M.

Archibald Stool

Design Jean-Marie Massaud, 2026

Models.

- swivel stool with seat h 66
- swivel stool with seat h 75

Upholstery.

- ColorSphere® (SC)
- Nest
- Soulful
- Fabric A
- Fabric B
- Fabric C
- C.O.M.

Removability. Not possible.

Seat base and legs. Solid wood available in two finishes:

- Ash in a wenge stain (32)
- Ash in a moka stain (61)
- Felt pads protect the part which touches the floor.
- Special additional finishes at extra cost:
- Ash stained according to sample
- Ash lacquered in a RAL colour according to sample.

Swivel versions. In this case, the base is equipped with a TORNA mechanism that allows 360° rotation and automatic return to the starting position.

Footrest. In rectangular-section stainless steel and mirror-polished on threesides.

Please note:
this catalogue shows only some technical drawings, in order
to know all the availabilities please refer to the current price list.

Blisscape — 2-Seater Sofa high armrests

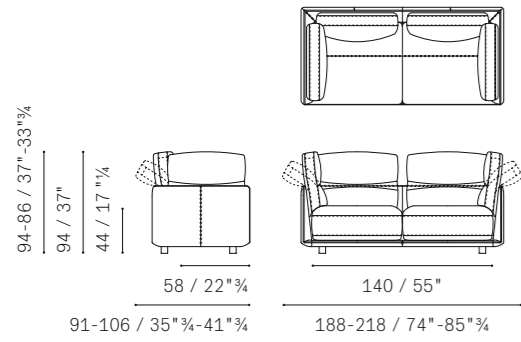

Blisscape — Sectional 2-Seater Sofa 1 high arm DX/SX

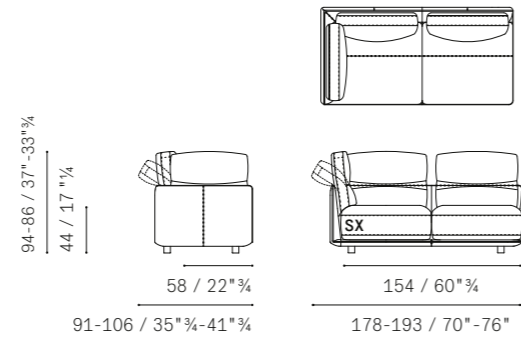

Blisscape — 45° Curved Sectional Armless Armchair

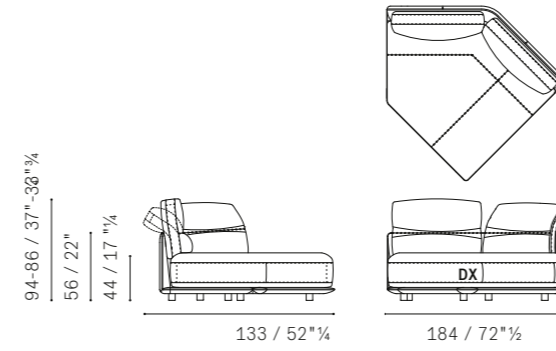

Blisscape — Corner 2-Seater Sofa DX/SX 1 high armrest

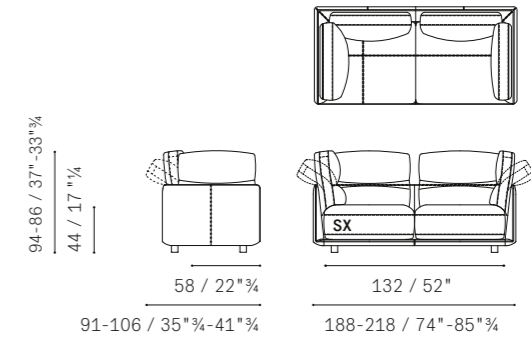

Blisscape — Large 2-Seater Sofa high arms

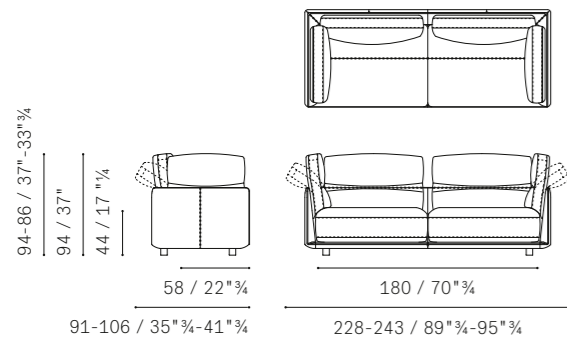

Blisscape — Sectional large 2-Seater Sofa 1 high arm DX/SX

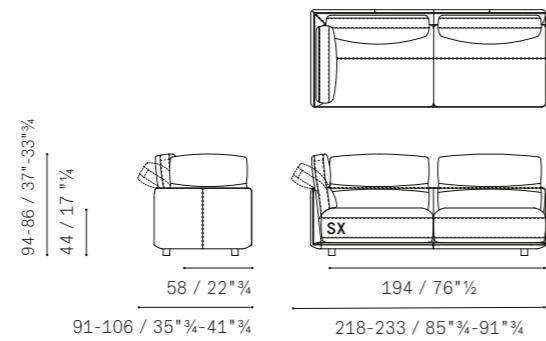

Blisscape — 45° Curved Sectional Armchair 1 low arm DX/SX

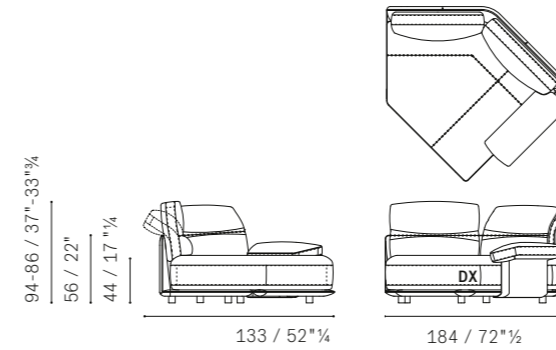

Blisscape — Corner Large 2-Seater Sofa DX/SX 1 high armrest

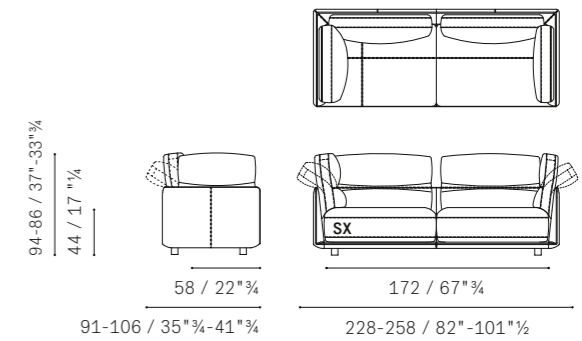

Blisscape — 3-Seater Sofa high arms

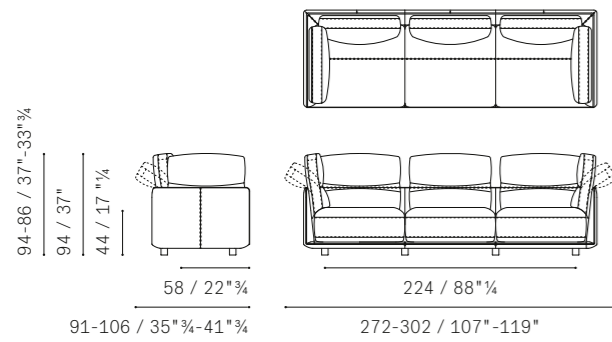

Blisscape — Sectional 3-Seater Sofa 1 high arm DX/SX

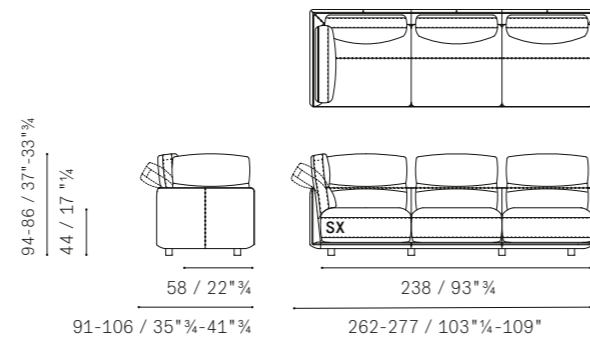

Blisscape — Corner 3-Seater Sofa DX/SX 1 high armrest

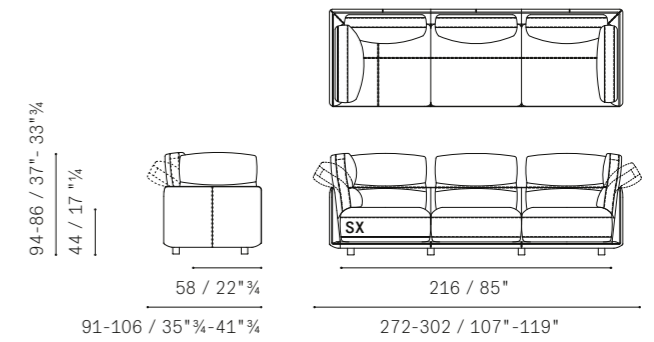

Blisscape — Large 3-Seater Sofa high arms

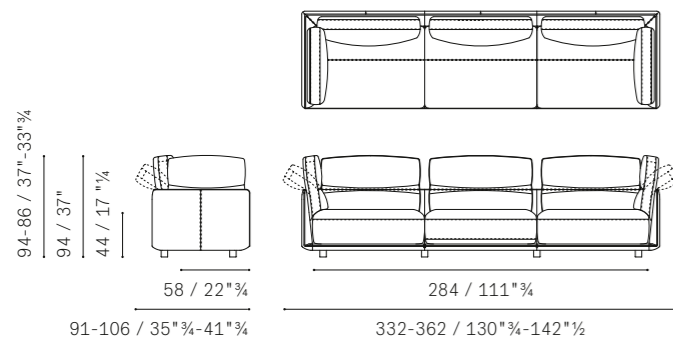

Blisscape — Sectional large 3-Seater Sofa 1 high arm DX/SX

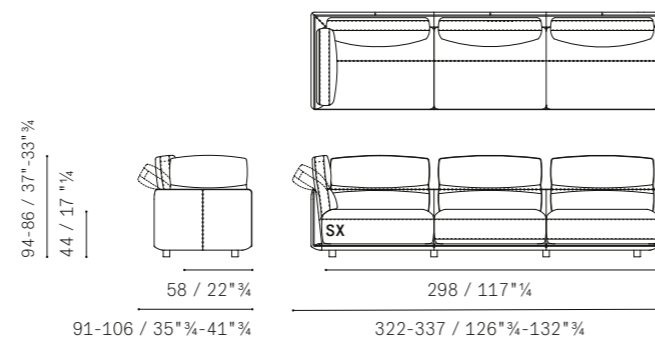

Blisscape — Corner Large 3-Seater Sofa DX/SX 1 high armrest

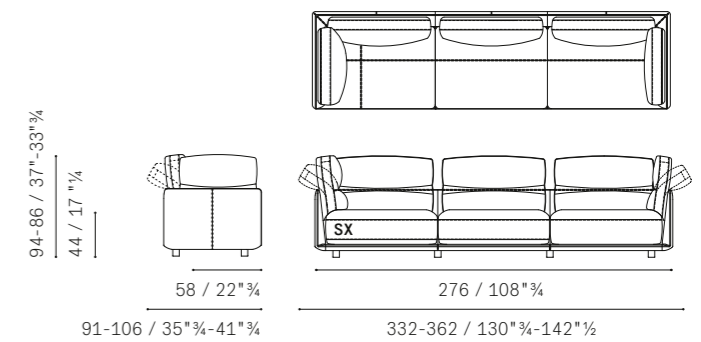

NOTE: The technical drawings of the Blisscape Deep model are not exhaustive and represent only part of the available range. For a complete overview of all variants and configurations, please refer to the price list.

NB: I disegni tecnici del modello Blisscape Deep non sono esaustivi e rappresentano unicamente una parte della gamma disponibile. Per la consultazione completa delle varianti e delle configurazioni si rimanda al listino prezzi.

Blisscape Deep — 2-Seater Sofa high armrests

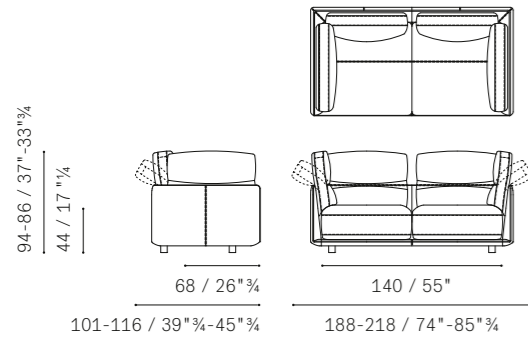

Blisscape Deep — 3-Seater Sofa high arms

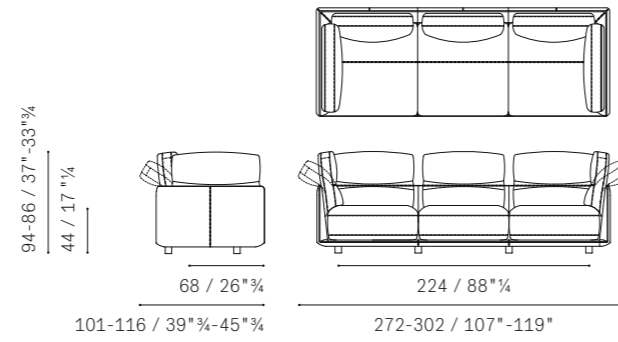

Blisscape Deep — Ottoman

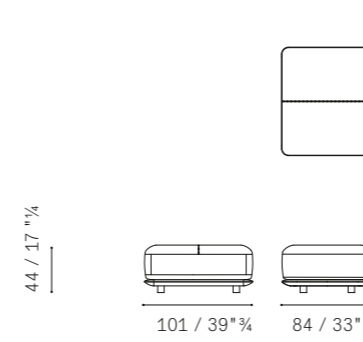

Blisscape Deep — Large ottoman

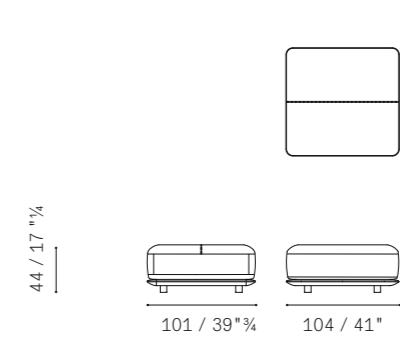

Blisscape Deep — 2-Seater Sofa low armrests

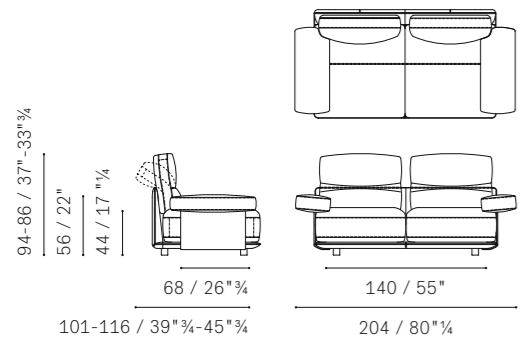

Blisscape Deep — 3-Seater Sofa low armrests

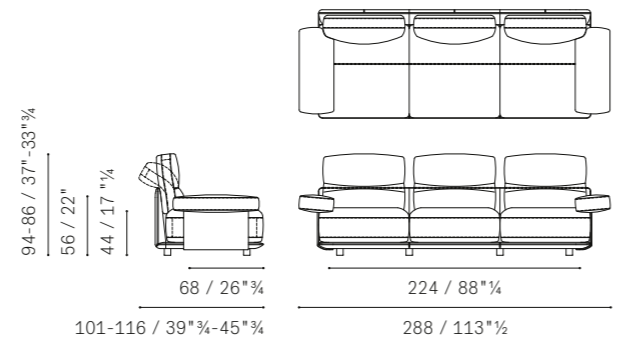

Blisscape Deep — Sectional Armless 2-Seater Sofa

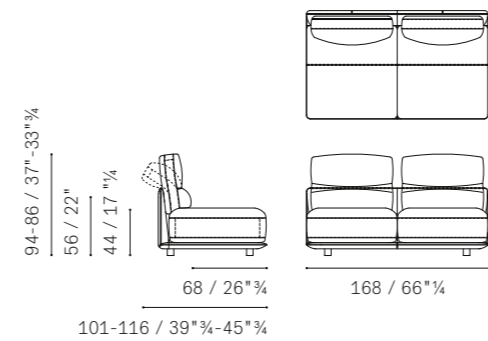

Blisscape Deep — Sectional 2-Seater Sofa 1 high arm DX/SX

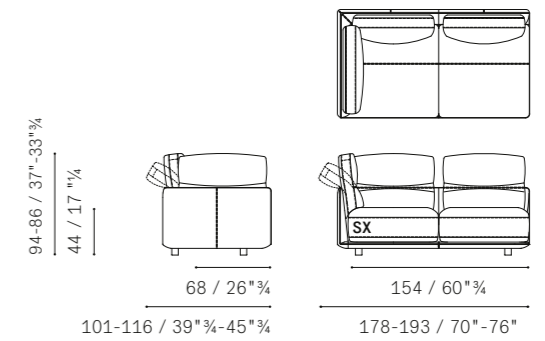

Blisscape Deep — Large 2-Seater Sofa high arms

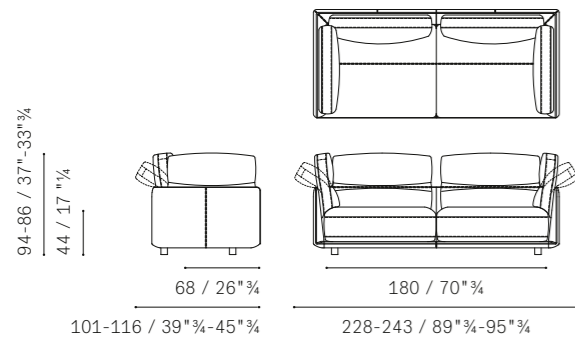

Blisscape Deep — Large 3-Seater Sofa high arms

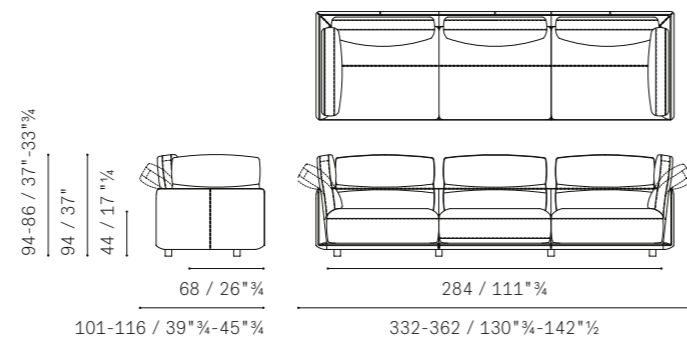

Blisscape Deep — Sectional 2-Seater Sofa 1 low arm DX/SX

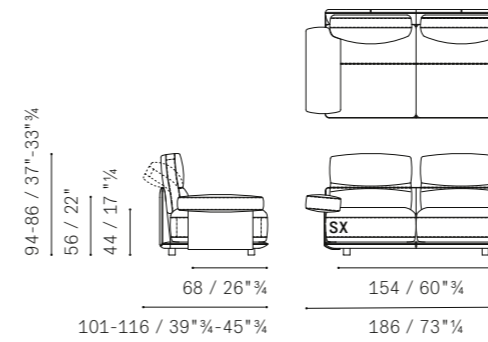

Blisscape Deep — Sectional Armless Large 2-Seater Sofa

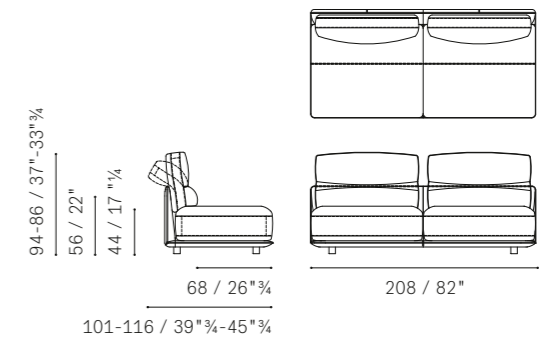

Blisscape Deep — Large 2-Seater Sofa low arms

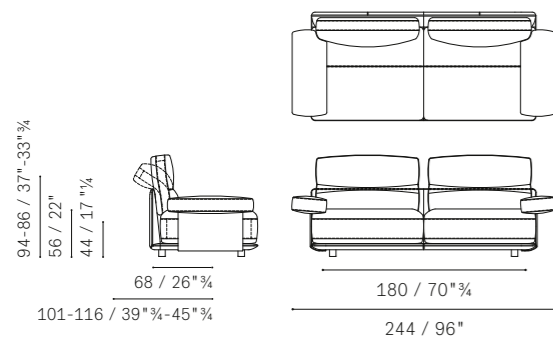

Blisscape Deep — Large 3-Seater Sofa low arms

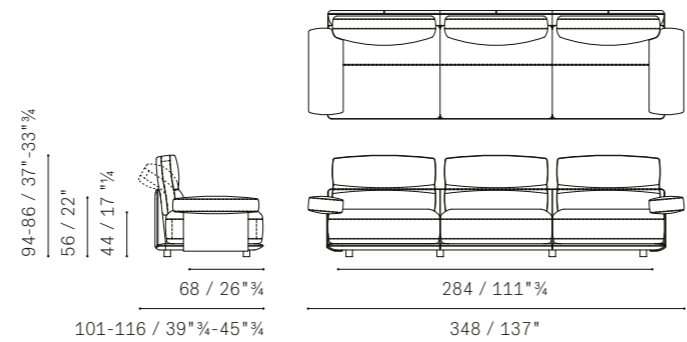

Blisscape Deep — Sectional large 2-Seater Sofa 1 high arm DX/SX

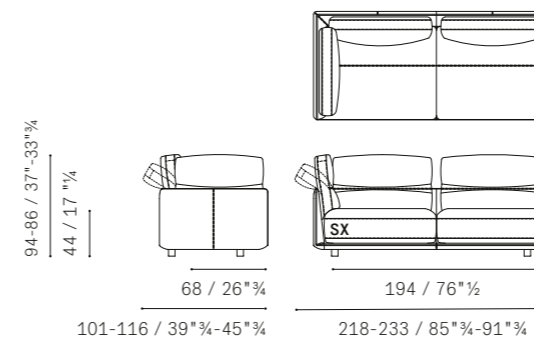

Blisscape Deep — Sectional Large 2-Seater Sofa 1 low arm DX/SX

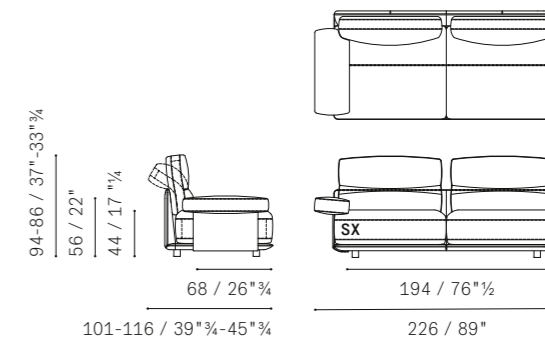

Blisscape Deep — Sectional 3-Seater Sofa 1 high arm DX/SX

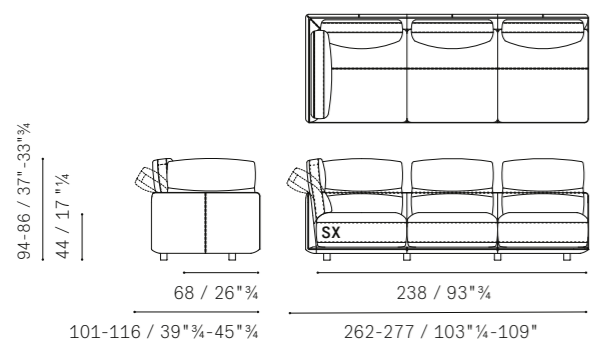

Blisscape Deep — 45° Curved Sectional Armless Armchair

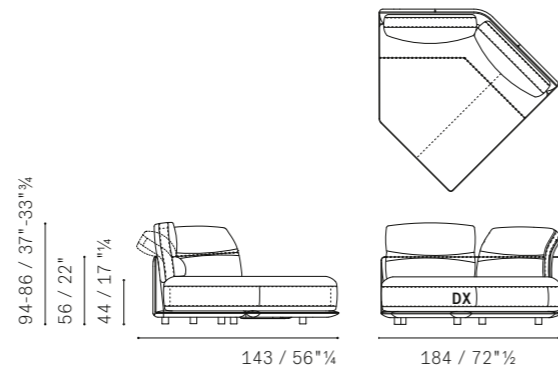

NOTE: The technical drawings of the Blisscape Deep model are not exhaustive and represent only part of the available range. For a complete overview of all variants and configurations, please refer to the price list.

NB: I disegni tecnici del modello Blisscape Deep non sono esaustivi e rappresentano unicamente una parte della gamma disponibile. Per la consultazione completa delle varianti e delle configurazioni si rimanda al listino prezzi.

Blisscape Deep — Corner Large 2-Seater Sofa DX/SX 1 high armrest

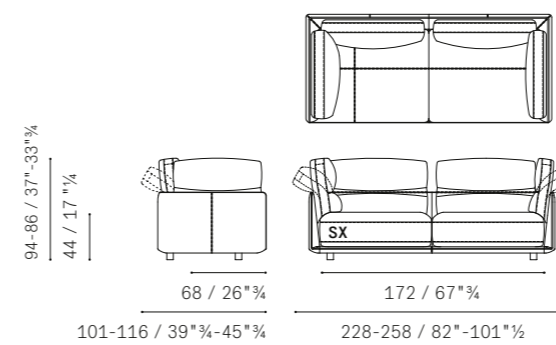

Blisscape Deep — Corner 3-Seater Sofa DX/SX 1 low armrest

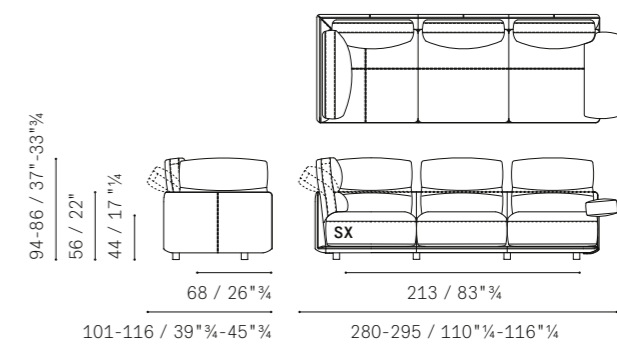

Blisscape Deep — Sectional 3-Seater Sofa 1 low arm DX/SX

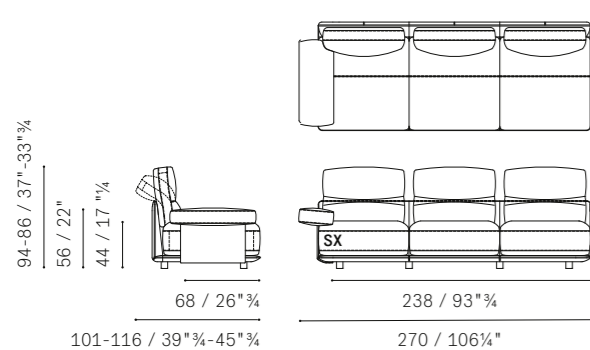

Blisscape Deep — 45° Curved Sectional Armchair 1 low arm DX/SX

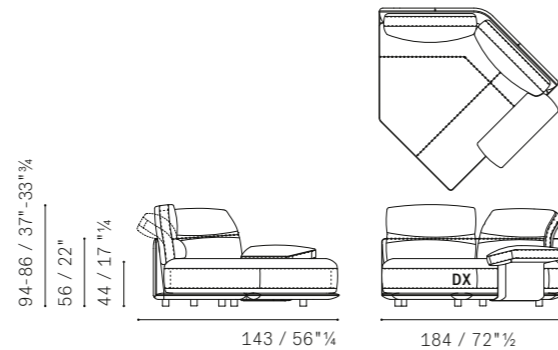

Blisscape Deep — Corner Large 2-Seater Sofa DX/SX 1 low armrest

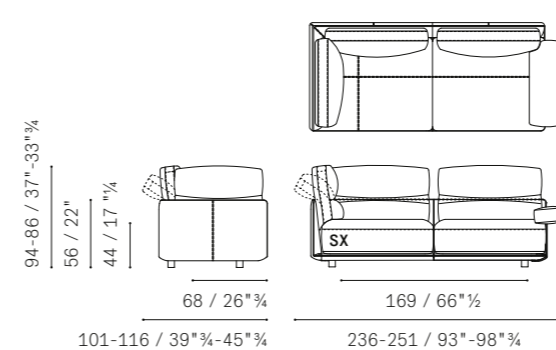

Blisscape / Blisscape Deep
Designed by Ludovica Serafini + Roberto Palomba, 2026

Depth. The system consists of modules available in two different depths
- Blisscape
- Blisscape Deep
PLEASE NOTE: For aesthetic/technical reasons, modules with different depths can be combined within the same composition only when the cushions are upholstered in fabric.

Seat cushion. Available in two versions:
- "Soft comfort", with polyester padding and polyurethane foam in different densities, including viscoelastic foam.
- "Firm comfort", with polyester padding and polyurethane foam in different densities, including high-tech foam and viscoelastic foam

Upholstery. Entirely in Pelle Frau® (including bicolor options) or in combinations of different materials. The first upholstery is applied to the structure, while the second is applied to the seat, backrest, and armrest cushions.

- ColorSphere® (SC)
- ColorSphere® (SC) two-tone*
- ColorSphere® (SC) / Fabric A
- ColorSphere (SC) / Fabric B
- ColorSphere (SC) / Fabric C
- ColorSphere (SC) / C.O.M.
- Heritage
- Heritage / Fabric A
- Heritage / Fabric B
- Heritage / Fabric C
- Heritage / C.O.M.
- Nest
- Nest two-tone*
- Nest / Fabric A
- Nest / Fabric B
- Nest / Fabric C
- Nest / C.O.M.
- Soulful
- Soulful / Fabric A
- Soulful / Fabric B
- Soulful / Fabric C
- Soulful / Fabric C.O.M.
- Velvety

Stitching. Tone-on-tone.

Blisscape Deep — Sectional Armless Chaise Longue

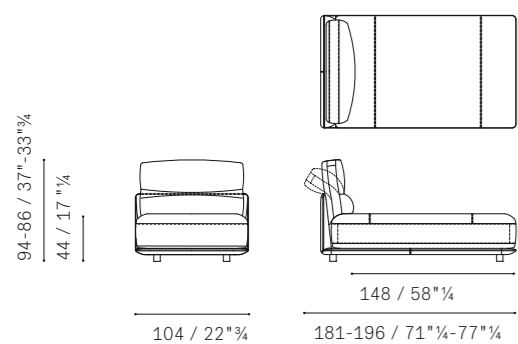

Blisscape Deep — Corner 2-Seater Sofa Dx/Sx 1 low armrest

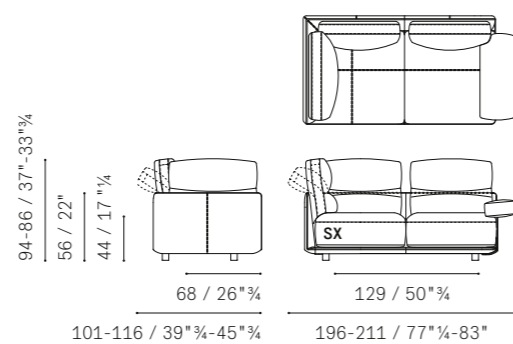

Blisscape Deep — Sectional Chaise Longue 1 low arm DX/SX

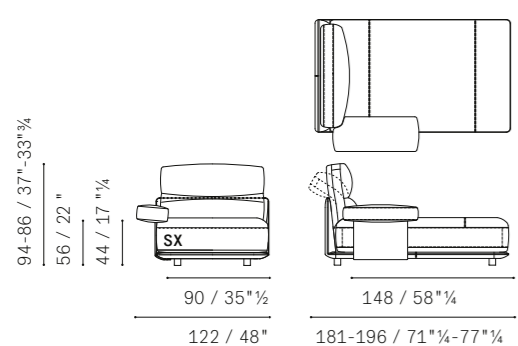

Blisscape Deep — Corner Armless Large 2-Seater Sofa DX/SX

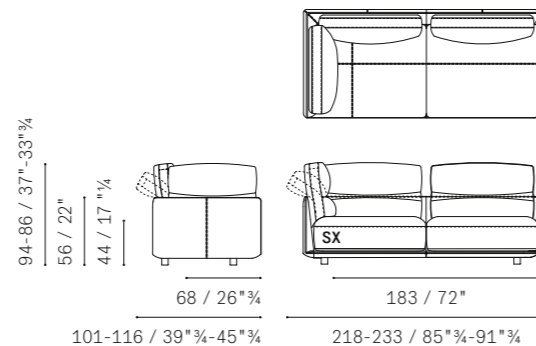

Blisscape Deep — Corner Armless 3-Seater Sofa DX/SX

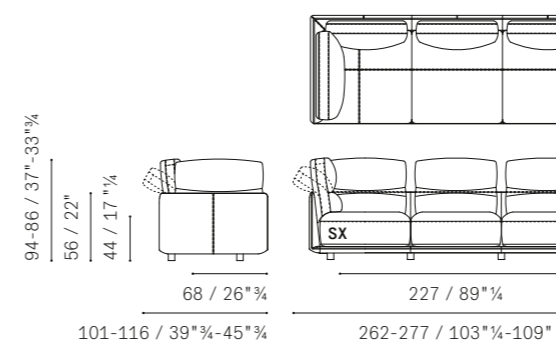

Blisscape Deep — Corner 3-Seater Sofa DX/SX 1 high armrest

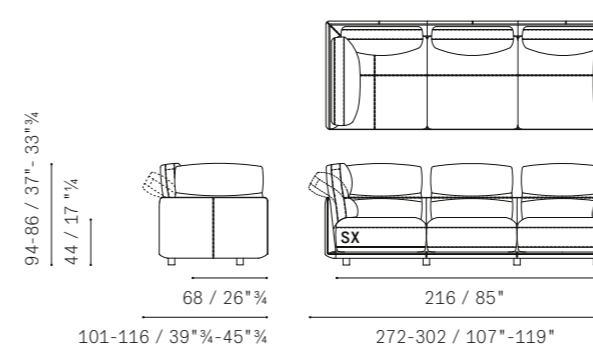

Blisscape Low Table — Dual shelf low table 90×45 - leather top

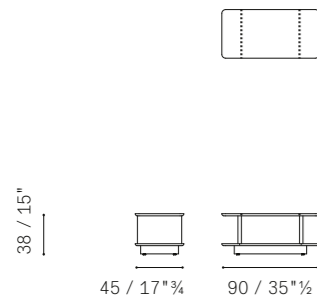

Blisscape Low Table — Dual shelf low table 90×45 - marble top

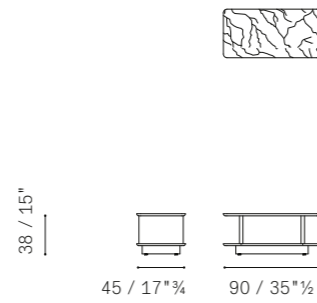

Please note:
this catalogue shows only some technical drawings, in order
to know all the availabilities please refer to the current price list.

Blisscape Low Table — Low table Ø 120 - leather top

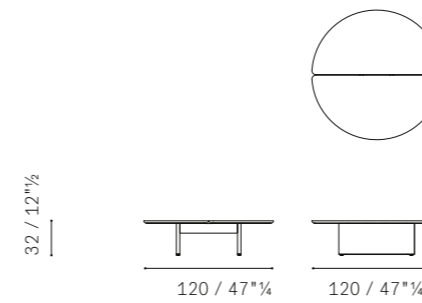

Blisscape Low Table — Low table Ø 120 - marble top

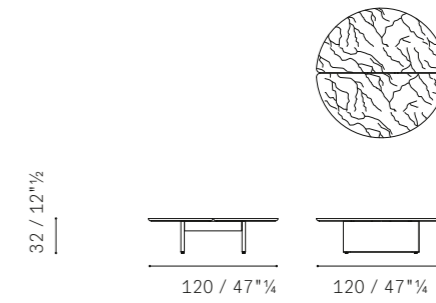

Blisscape Low Table — Dual shelf low table 100×45 - leather top

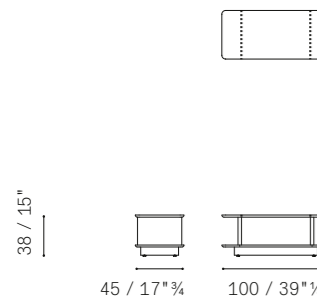

Blisscape Low Table — Dual shelf low table 100×45 - marble top

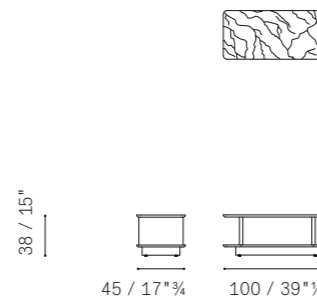

Blisscape Low Table
Designed by Ludovica Serafini + Roberto Palomba, 2026

- Items.**
- 100×100 h32
 - Ø120 h32
 - 150×40 h38 (ideal as sofa-back console)
 - 100×45 h38 (dual-shelf table, also usable as a terminal element for the Blisscape sofa)
 - 90×45 h38 (dual-shelf table, also usable as a terminal element for the Blisscape sofa)

Base upholstery. In Pelle Frau® ColorSphere® leather (SC).

- Top.**
- Pelle Frau® ColorSphere® (SC)
 - Carrara White marble, brilliant
 - Carrara White marble, semi-brilliant
 - Calacatta marble, brilliant
 - Calacatta marble, semi-brilliant
 - Arabescato Venato marble, brilliant
 - Arabescato Venato marble, semi-brilliant
 - Fior di Pesco marble, brilliant
 - Fior di Pesco marble, semi-brilliant
 - Marquinia marble, brilliant
 - Marquinia marble, semi-brilliant
 - Ombra di Caravaggio marble, brilliant
 - Ombra di Caravaggio marble, semi-brilliant

Blisscape Low Table — Low table/Console 150×40 - leather top

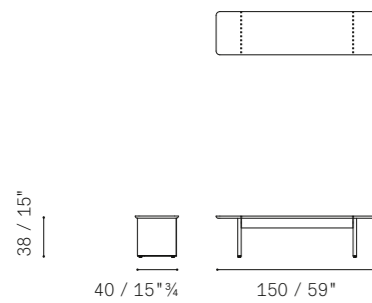

Blisscape Low Table — Low table / Console 150×40 - marble top

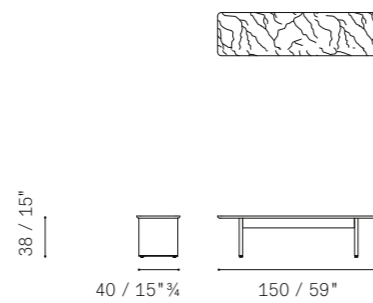

Blisscape Low Table — Low table 100×100 - leather top

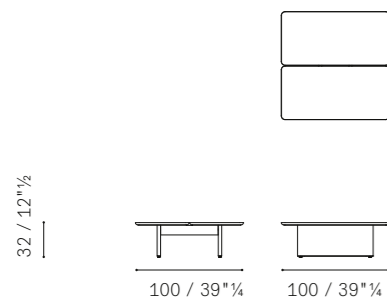

Blisscape Low Table — Low table 100×100 - marble top

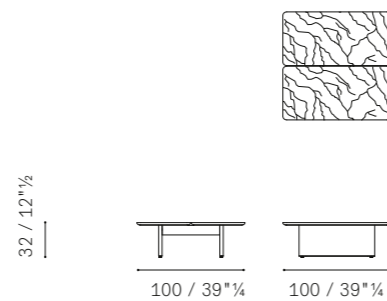

Cuiré — Low table 85×85 - marble top

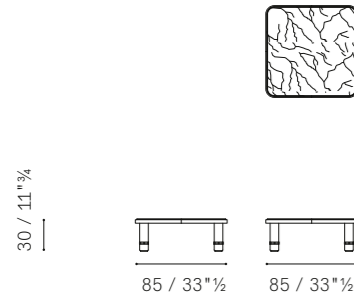

Cuiré — Low table 85×85 - glass top

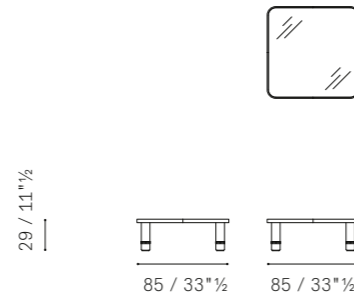

Cuiré — Low table 150×85 - marble top

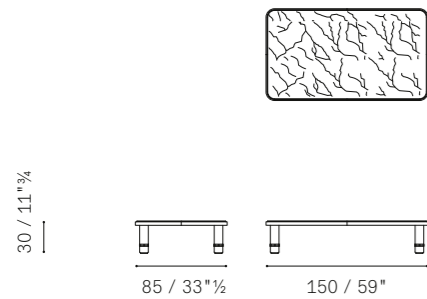

Cuiré — Low table 150×85 - glass top

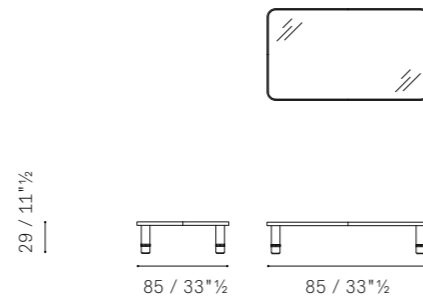

Cuiré — Low table 120×120 - marble top

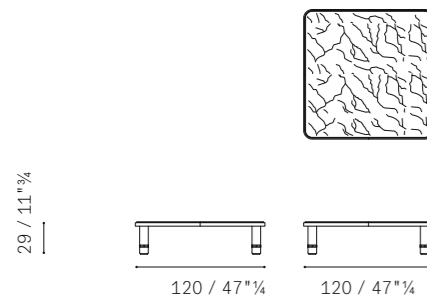

Cuiré — Low table 120×120 - glass top

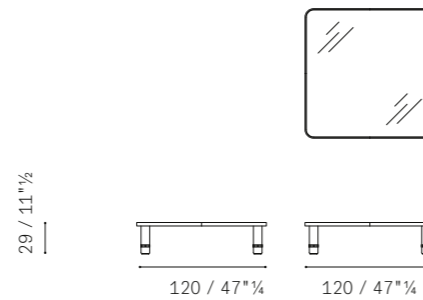

Cuiré
Designed by Poltrona Frau Style & Design Centre, 2026

Upholstery of legs and top frame. In Pelle Frau® ColorSphere® (SC). PLEASE NOTE. Upholstery can be freely chosen when the top is in marble. When the top is in back-painted glass, the leather upholstery matches the color of the glass top and CANNOT be changed.

Feet. Made of metal, cylindrical in shape and upholstered in Pelle Frau® ColorSphere® (SC).

Top. Available in
- back-painted glass
- marble

Back-painted glass top. Available in the following finishes matched with the corresponding Pelle Frau® ColorSphere® color.
- Tortora SC 23
- Quarzo Fumè SC 31
- Creta SC 53
- Limo SC 177
- Steel Blue SC 254

Marble top. Made from a single slab of marble available in the following finishes:

- Carrara White marble, brilliant
- Carrara White marble, semi-brilliant
- Carrara White marble with natural glossy finish
- Calacatta marble, brilliant
- Calacatta marble, semi-brilliant
- Calacatta marble with natural glossy finish
- Arabescato Venato marble, brilliant
- Arabescato Venato marble, semi-brilliant
- Arabescato Venato marble with natural glossy finish
- Marquinia marble, brilliant
- Marquinia marble, semi-brilliant
- Marquinia marble with natural glossy finish
- Ombra di Caravaggio marble, brilliant
- Ombra di Caravaggio marble, semi-brilliant
- Ombra di Caravaggio marble with natural glossy finish

Please note:
this catalogue shows only some technical drawings, in order to know all the availabilities please refer to the current price list.

DomusCove — Main elements

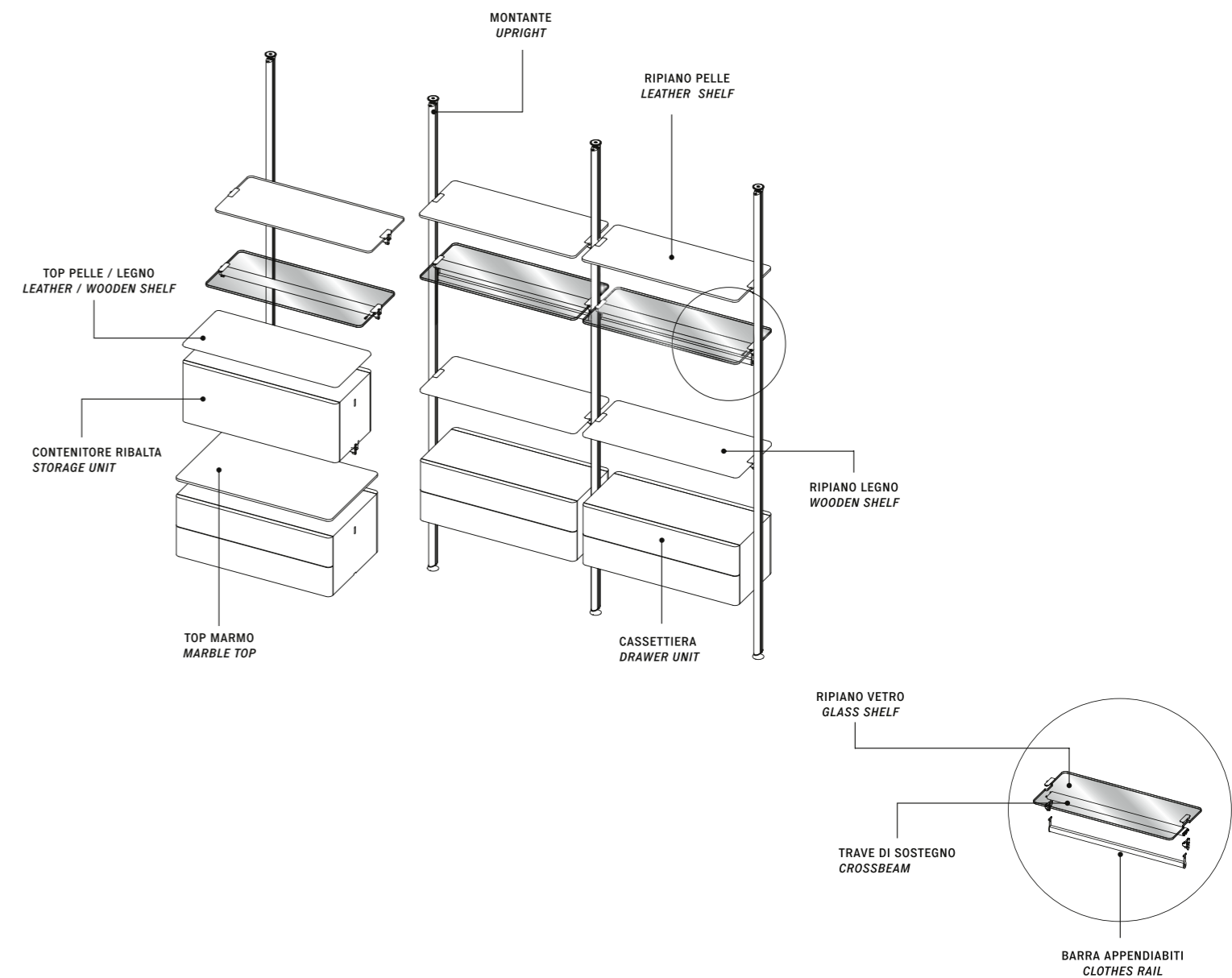

DomusCove
Designed by Dante Bonuccelli, 2026

Modules. Modules are available in three different center-to-center spacings:
- 80.6 cm
- 96.6 cm
- 127 cm

Wood components. All wooden parts are made of wood veneer available in a single Golden Walnut finish.

Upholstery. Upholstered parts are always in Pelle Frau® ColorSphere® leather, in a predefined selection of colors:
NB: At an additional cost, other colors from the ColorSphere® range can also be selected.

Marble. Tops for drawer units and flap-door units are also available in:
- Calacatta semi-brilliant marble
- Calacatta marble with a natural glossy finish

Glass. Shelves are available in:
- Extra-clear glass
- Bronze-tinted glass

Metal details. Exposed structural metal parts in titanium-painted aluminum.

System composition. The system consists of a series of main elements, fully customizable and progressively configurable: uprights, shelves, flap-door storage modules, beams, drawer units, tops, as well as accessories and optional elements.

DomusCove — Layout composition 01

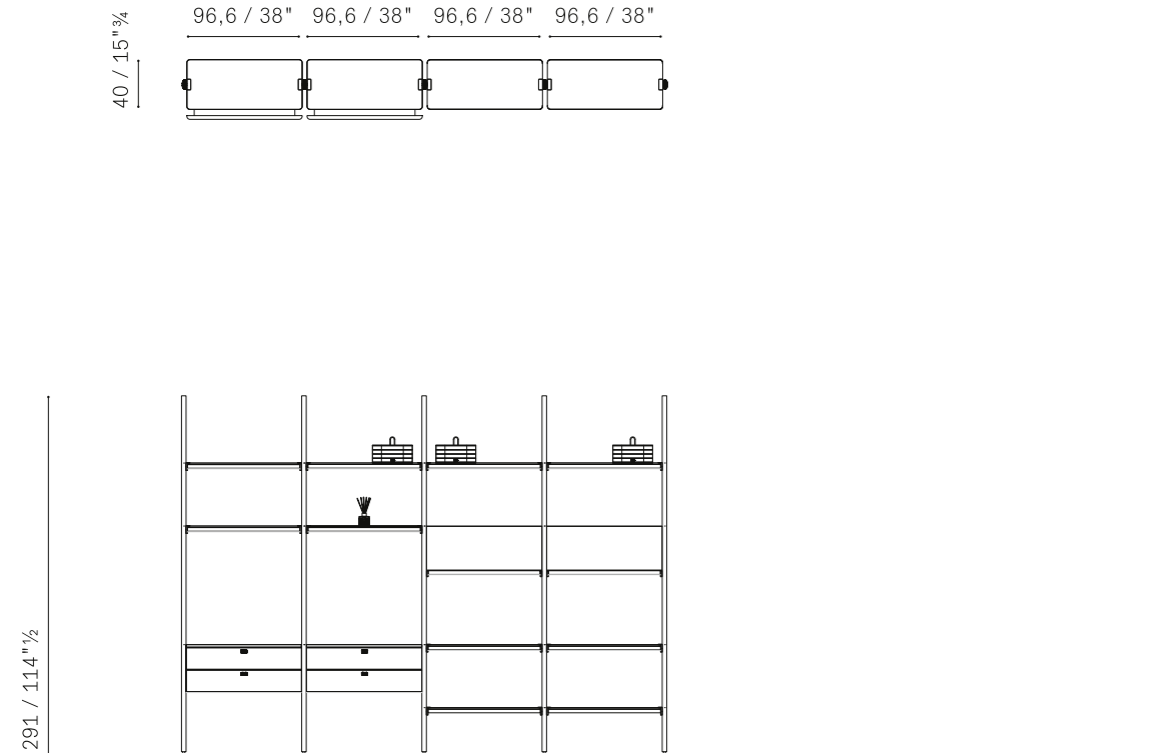

DomusCove — Layout composition 02

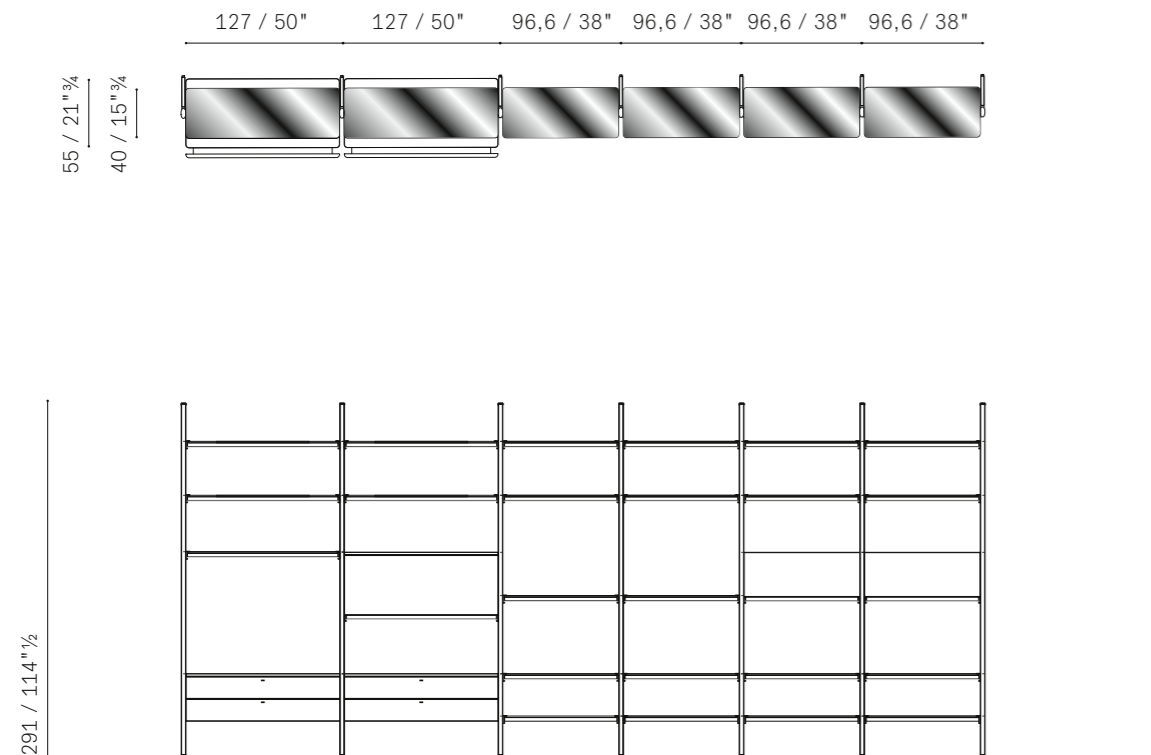

Please note:
this catalogue shows only some technical drawings, in order
to know all the availabilities please refer to the current price list.

DressCove — Layout composition 01

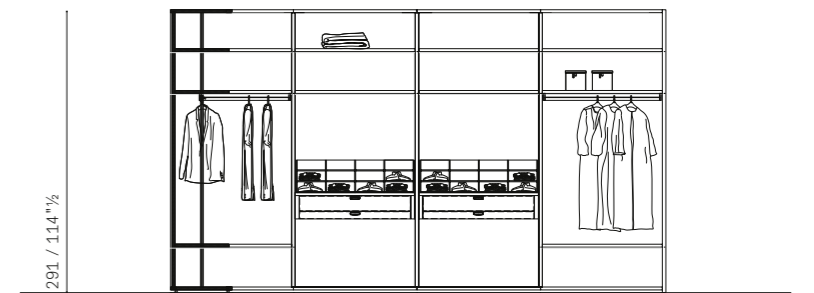
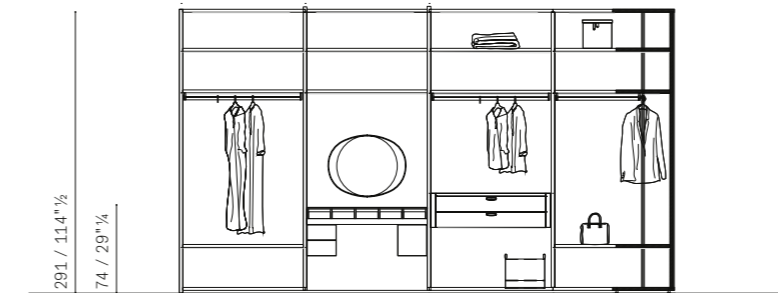
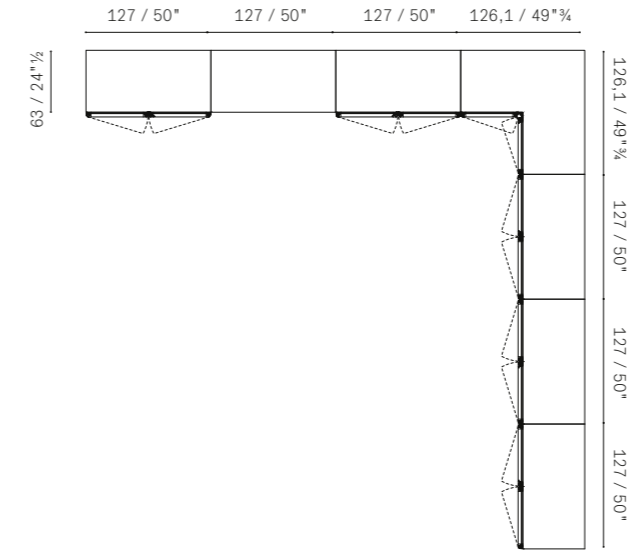

DressCove
Designed by Dante Bonuccelli, 2026

Doors, Structural Panels, Shelves, Drawers, Tops, and Fronts.

- wood veneer:
 - Dark Oak
 - Golden Walnut
 - Pickled Oak
 - Brown Oak
- Melamine:
 - Toasted Oak
 - Warm Walnut
 - Leather Effect

Metal Parts. Titan finish

- Doors and shelves:**
- Bronze glass
 - Stopsol bronze glass
 - Fluted bronze glass
 - Matt bronze glass

Doors, Uprights, Shelves, Tops, Front Panels, Components, and Accessories.

- Pelle Frau® ColorSphere® (SC)

DressCove — Layout composition 02

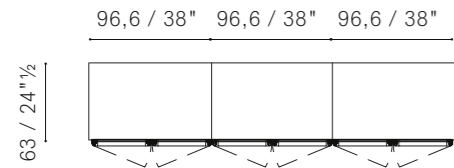

DressCove — Layout composition 03

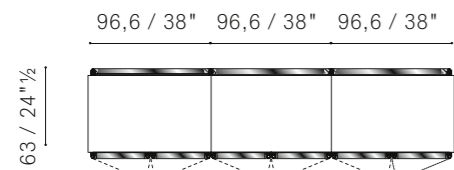

Please note:
this catalogue shows only some technical drawings, in order
to know all the availabilities please refer to the current price list.

Esedra — Small pouf

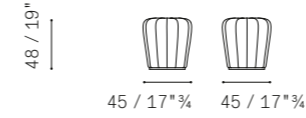

Esedra — Medium pouf

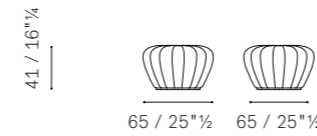

Esedra — Medium pouf with storage

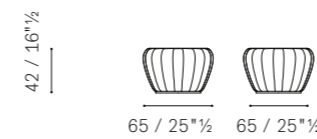

Esedra
Designed by Monica Förster, 2007/2026

- Items.**
- Esedra Small
 - Esedra Medium
 - Esedra Medium with storage
 - Esedra Large

- Upholstery (for Small, Medium, Large poufs).** Pelle Frau® leather:
- ColorSphere® (SC)
 - Heritage
 - Nest
 - Soulful
 - Velvety

- Upholstery (for Medium pouf with storage).** Pelle Frau® leather:
- ColorSphere® (SC)
 - ColorSphere® (SC) two-tone

Base. Made of MDF with a matte black lacquer finish.

Infinitamente 2.0 — Table

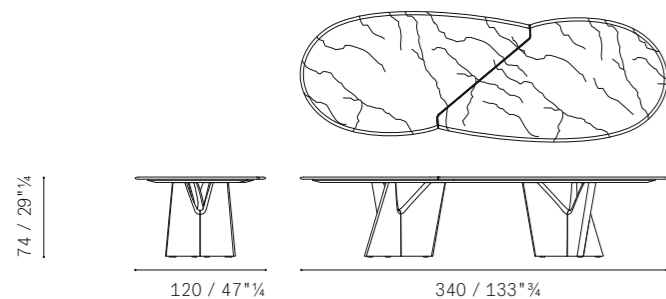

INFINITAMENTE 2.0

Designed by Roberto Lazzeroni, 2026

Base upholstery. In Pelle Frau® ColorSphere® leather (SC).

Marble top. The top is obtained from a single marble slab and consists of two opposing parts.

Marbles. The top is available in the following finishes:

- Carrara White marble, brilliant
- Carrara White marble, semi-brilliant
- Calacatta marble, brilliant
- Calacatta marble, semi-brilliant
- Arabescato Venato marble, brilliant
- Arabescato Venato marble, semi-brilliant
- Fior di Pesco marble, brilliant
- Fior di Pesco marble, semi-brilliant
- Marquinia marble, brilliant
- Marquinia marble, semi-brilliant
- Ombra di Caravaggio marble, brilliant
- Ombra di Caravaggio marble, semi-brilliant

Please note:
this catalogue shows only some technical drawings, in order
to know all the availabilities please refer to the current price list.

Kubaya — Pouf 86×121 with feet

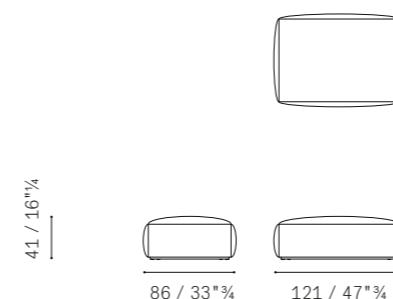

Kubaya

Designed by Poltrona Frau Style & Design Centre, 2026

Upholstery. Pelle Frau® leather:

- ColorSphere® (SC)
- Heritage
- Nest
- Soulful*
- Motif Knits*

*NB: Only for the 86×61 and 86×86 versions. The 86×121 size is not available in these upholsteries.

Removability. Not possible.

Base. Available in two versions:
in black textured painted MDF with black plastic feet to protect the floor.
with swivel castors concealed within a recessed housing.

Kubaya — Pouf 86×121 with castors



LieLow — bed

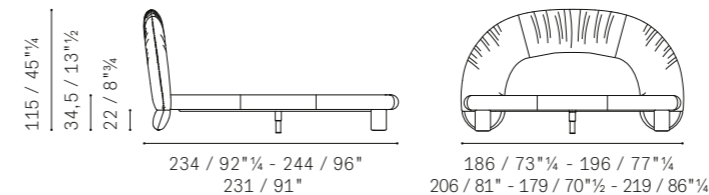

LieLow

Designed by Faye Toogood, 2026

Front feet. Cylindrical aluminum feet upholstered in Pelle Frau® leather.
Fitted with plastic floor-protection caps.

Rear feet. The semi-circular headboard extends to the floor via two semi-circular supports originating from its ends.

Upholstery. In Pelle Frau®:

- ColorSphere® (SC)
- Nest

Back of headboard. Available upholstered in:

- Fabric (Poltrona Frau Jacquard fabric)
- Leather (matching the upholstery)

Mattress Length (except for "Queen-size" and "King-size" versions).

- 200 cm
- 210 cm

Note. Rest Plans and Mattresses are shown and quoted separately,
see dedicated section.

Kubaya — Pouf 86×61 with feet

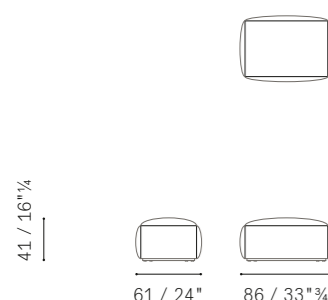

Kubaya — Pouf 86×86 with feet

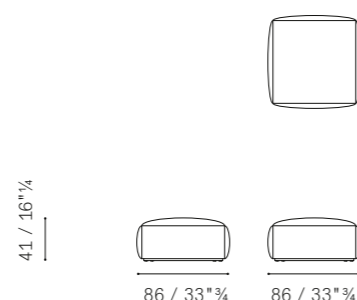

Kubaya — Pouf 86×61 with castors

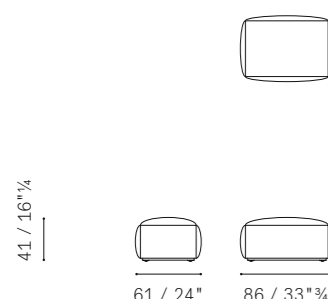

Kubaya — Pouf 86×86 with castors

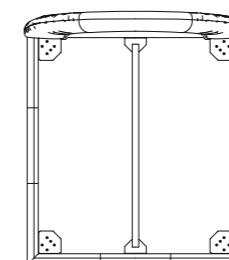
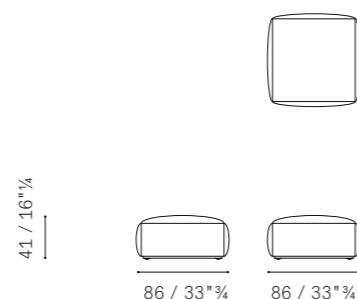

LieLow — night stable with drawer

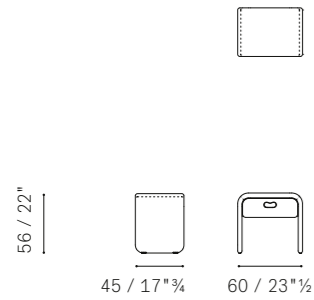

LieLow — night stable with shelf

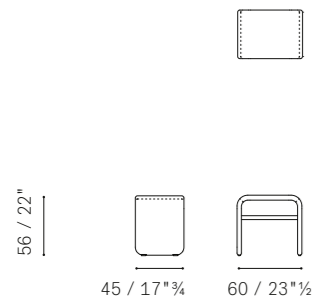

LieLow Bedside Table
Designed by Faye Toogood, 2026

- Items.**
- with shelf
 - with drawer

Upholstery. In Pelle Frau®:
- ColorSphere® (SC)

Stitching. Tone-on-tone.

Back of bedside table. Available in two versions:
- extra light natural maple
- leather-upholstered (matching the upholstery)

ACCESSORIES AND OPTIONALS

Drawer pad. Made of beige Alcantara®, available as a decorative and protective element for the drawer.

Stock'N Roll — Home Desk

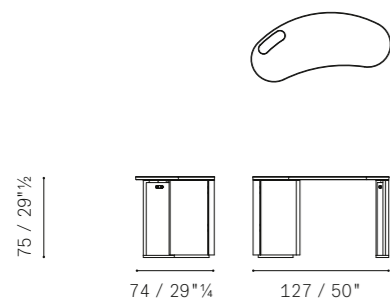

Stock'N Roll — Dressing Table

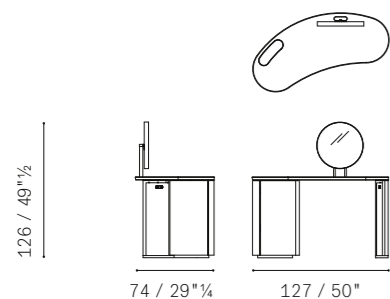

Stock'N Roll
Designed by Sebastian Herkner, 2026

- Items.**
- Home Desk
 - Dressing Table

Storage compartment. Available with right-hand or left-hand opening. The opening direction is distinguished by the position of the hinges as seen from the front:
- Right-hand Opening (hinges on the right and handle on the left)
- Left-hand Opening (hinges on the left and handle on the right)

Internal equipment.
> Shelves
> Tray

External and internal covering. In Pelle Frau® ColorSphere® (SC) is also available in a two-tone option, with different colours for the exterior and interior.

Top. Upholstered in Pelle Frau® ColorSphere® (SC), matched to either the exterior or interior surface of the unit.
Adjustable mirror (only for the dressing table version).

Stitching. Tone on tone.

Metal details. All visible metal components feature a gunmetal finish.

ACCESSORIES AND OPTIONALS

USB charging outlet. This solution includes two USB ports, Type A and Type C, positioned on the inner side of the leg in the under-top area.

Pen holder. Available separately. Upholstered in Pelle Frau® Motif Weavers®.

Please note:
this catalogue shows only some technical drawings, in order to know all the availabilities please refer to the current price list.

Zabriskie — Low Cabinet 184×53, marble top

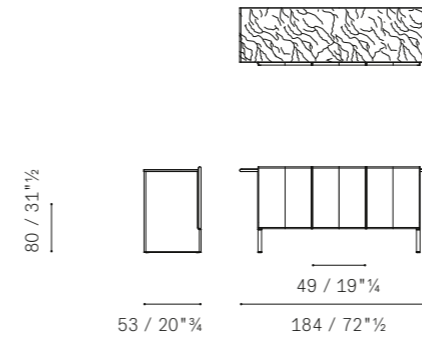

Zabriskie — Low Cabinet 184×53, wooden top

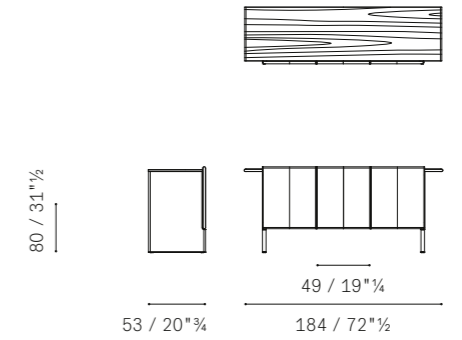

Zabriskie — Low Cabinet 234×53, marble top

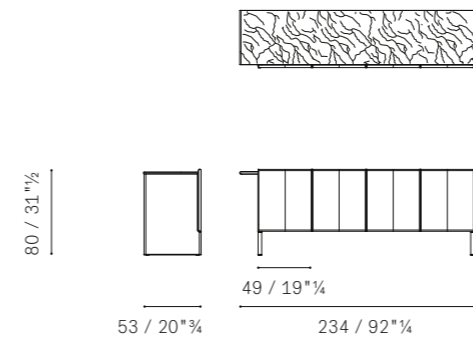

Zabriskie — Low Cabinet 234×53, wooden top

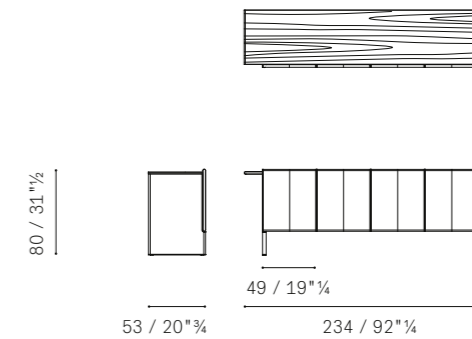

Zabriskie — Low Cabinet 284×53, marble top

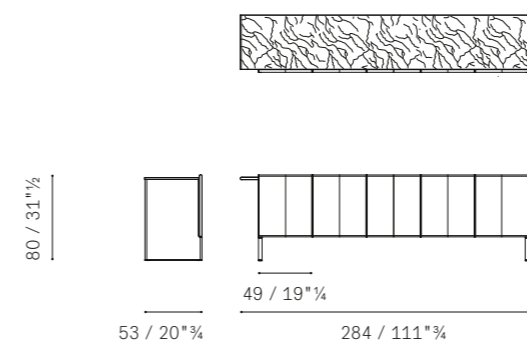

Zabriskie — Low Cabinet 284×53, wooden top

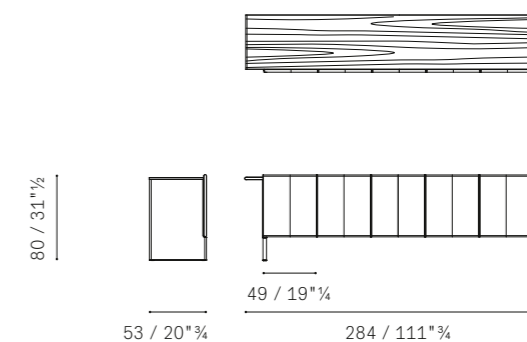

Zabriskie — Multimedia Cabinet 234×53, marble top

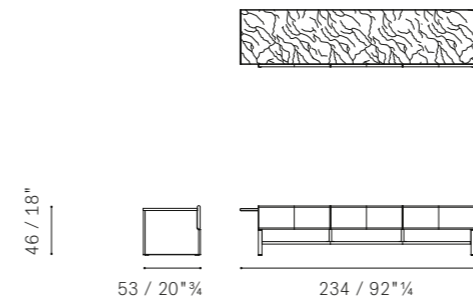

Zabriskie — Multimedia Cabinet 234×53, wooden top

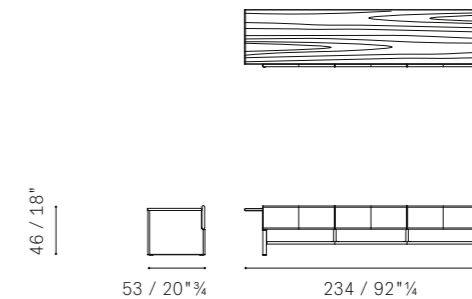

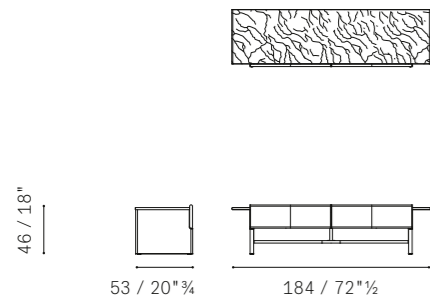
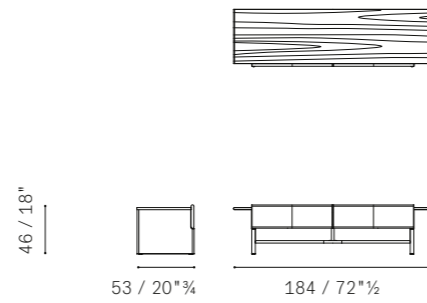
Zabriskie — Multimedia Cabinet 184×53, marble top**Zabriskie** — Multimedia Cabinet 184×53, wooden top**Zabriskie**

Designed by Roberto Lazzeroni, 2026

Item.

- Low Cabinet 184×53 h79 (3 doors)
- Low Cabinet 234×53 h79 (4 doors)
- Low Cabinet 284×53 h79 (5 doors)
- Multimedia Cabinet 234×53 h46 (3 drawers)
- Multimedia Cabinet 184×53 h46 (2 drawers)

TOP.

- Canaletto walnut
- Carrara White marble, brilliant
- Carrara White marble, semi-brilliant
- Calacatta marble, brilliant
- Calacatta marble, semi-brilliant
- Arabescato Venato marble, brilliant
- Arabescato Venato marble, semi-brilliant
- Marquinia marble, brilliant
- Marquinia marble, semi-brilliant
- Ombra di Caravaggio marble, brilliant
- Ombra di Caravaggio marble, semi-brilliant

Interior. In extra-light natural maple.**OPTIONALS****FOR LOW CABINET:**

- Overhead shelves (only for Low Cabinet 234 cm and 284 cm)
- Rectangular tray with leather upholstery
- Internal drawer
- Drawer divider in extra-light natural maple veneered wood
- Drawer mat in leather upholstery

FOR MULTIMEDIA CABINET:

- Drawer divider in extra-light natural maple veneered wood
- Drawer mat in Pelle Frau® leather

Please note:
this catalogue shows only some technical drawings, in order
to know all the availabilities please refer to the current price list.

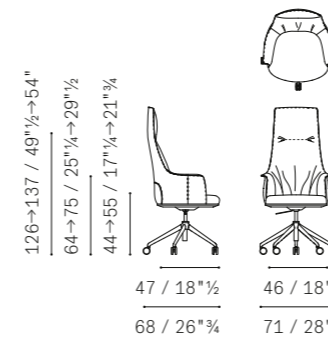
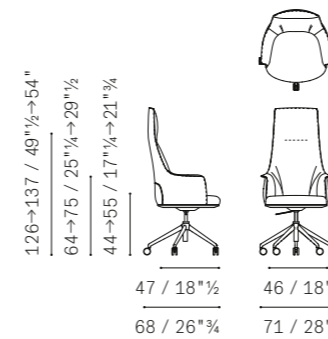
Archibald Task | President Chair — Leather upholstery**Archibald Task | President Chair** — Fabric upholstery**Archibald Task Chair**

Design Jean-Marie Massaud, 2026

Underseat protection casing.

- embossed black
- upholstered in Pelle Frau® leather matching the shell.

Base finishes.

- Polished aluminum
- Black painted aluminum

Supports.

- Soft self-braking swivel "W" wheels (recommended for floors such as granite, ceramic, marble, wood, and linoleum)
- Hard self-braking swivel "H" wheels (recommended for textile fiber surfaces)
- Swivel glides made of thermoplastic material with Teflon protection pads (suitable for all surfaces).

Wheel finishes.

- Chrome
- Black

Upholstery.

- ColorSphere® (SC)
- Nest
- Soulful
- Fabric A
- Fabric B
- Fabric C
- C.O.M.

Functions.

- > 360° rotation
- > Seat height adjustment via gas spring
- > Slight recline up to a maximum of 9°. The backrest cannot be locked in the reclined positions.

Gio Ponti Oro — Floor lamp

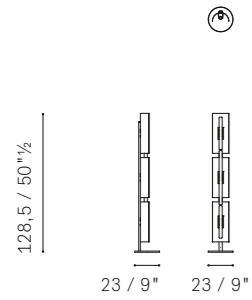

Gio Ponti Oro

Designed by Gio Ponti, 1950/2026

Finish. Anodized aluminium with brass finish

Moonbeam — Floor lamp

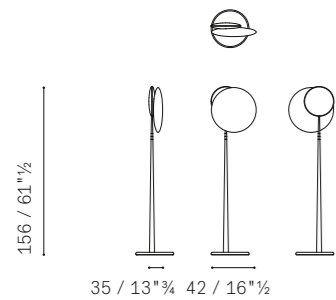

Moonbeam

Designed by Six N.Five, 2026

Models.

- large table lamp
- floor lamp

Base. Brass-galvanized aluminum.

Front disc.

- Available:
- galvanized brass aluminum
 - covered in Pelle Frau® ColorSphere® in the following colors:
 - SC 04 Latte
 - SC 23 Tortora
 - SC 176 Darsena
 - SC 96 Mattone

Light source. Made of blown glass with a matte acid-etched milk-white finish. The light source is positioned behind the front disc and is equipped with an internal LED with adjustable light temperature, from warm to cool, for a striking effect.

Functions.

- > Touch on/off switch
- > Dimmer functionality for light modulation up/down
- > Kelvin temperature adjustment

Certifications. CE. This product is compliant for sale in Europe, UK, China, USA, Australia/New Zealand

Moonbeam — Large table lamp

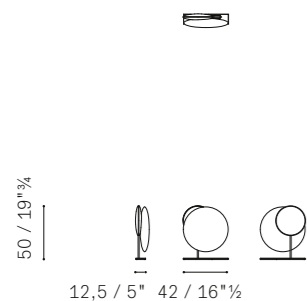

Please note:
this catalogue shows only some technical drawings, in order
to know all the availabilities please refer to the current price list.

Nymph Air — Pendant lamp

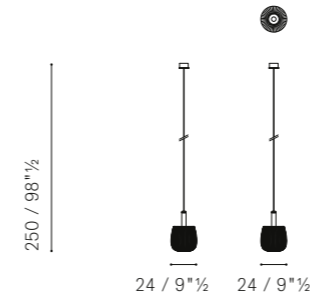

Nymph Air

Designed by Sebastian Herkner, 2026

Models.

- Pendant lamps:
- Nymph Air
 - Nymph Air Medium

Lampshade. In blown glass with ribbed texture, available in the following finishes:

- Satin milk white
- Fumé

Light source. Composed of a cylindrical tube made of polymethyl methacrylate (PMMA), at the base of which a LED module is housed. The surface texture of the cylinder creates a distinctive lighting effect.

Certifications. CE. This product is compliant for sale in Europe, UK, China, USA, Australia/New Zealand

Light source. Depending on the suspension version (Air or Air Medium), the light source has different dimensions:

- Air → small light source Ø24 cm
- Air Medium → medium light source Ø35 cm

Ceiling rose.

- Available in:
- CE / CCC (Ø 6 cm)
 - UL (Ø 12 cm)

Electrical cables. 2.5 m long, transparent.

Nymph Air — Medium pendant lamp

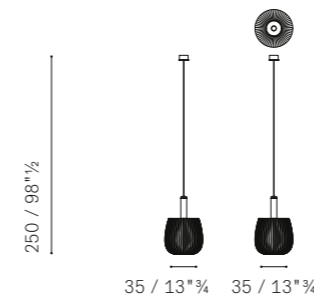

Tullissè — Lamp

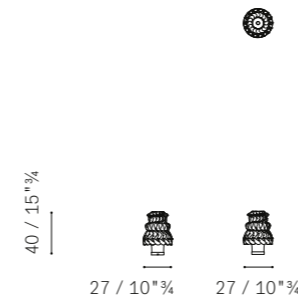

Tullissè

Designed by Atelier Oï

Dimensions.

- Small
- Medium

Finishes. Pelle Frau® ColorSphere® in the following color combinations:

- SC 66 India / SC 31 Quarzo Fumé
- SC 278 Atlantic Blue / SC 233 Bardiglio
- SC148 Lacca / SC 31 Quarzo

Tullissè — Large lamp

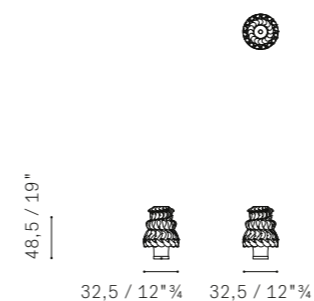

CONTACTS

Poltrona Frau S.p.A
a socio unico
Sede legale in Meda (MB)
Via Luigi Busnelli 1
20821 Italy

Sede operativa in Tolentino (MC)
Via Sandro Pertini 22
62029 Italy

Tel. +39 0733 909.1
Fax +39 0733 971600

www.poltronafrau.com

CREDITS

Project commissioned by the
Marketing & Communications
dept. of Poltrona Frau spa

Graphic design
studio FM milano

Lifestyle CGI Photography
Fuorifuoco Agency

Still-life Photography
Alessio D'Aniello

Lifestyle Photography
Alessio D'Aniello

Styling Lifestyle Photography
Sara Dassi

Post production/Color selection
Pan Group Milano

© POLTRONA FRAU 2026

Poltrona Frau reserves the right to modify the products and the components in this price list, without any prior notice.
Company with certified Quality Management System in accordance with ISO 9001, certified Environmental Management System in accordance with ISO 14001, certified Occupational Health and Safety Management System in accordance with BS OHSAS 18001, certified Chain of Custody System in accordance with Forest Stewardship Council® FSC-STD-40-004 (FSC-C153281).

Company subject to management and co-ordination of Haworth Italy Holding S.r.l.

